

American Standard

HEATING & AIR CONDITIONING

SPLIT SYSTEM HEAT PUMP

1½ — 5 TON

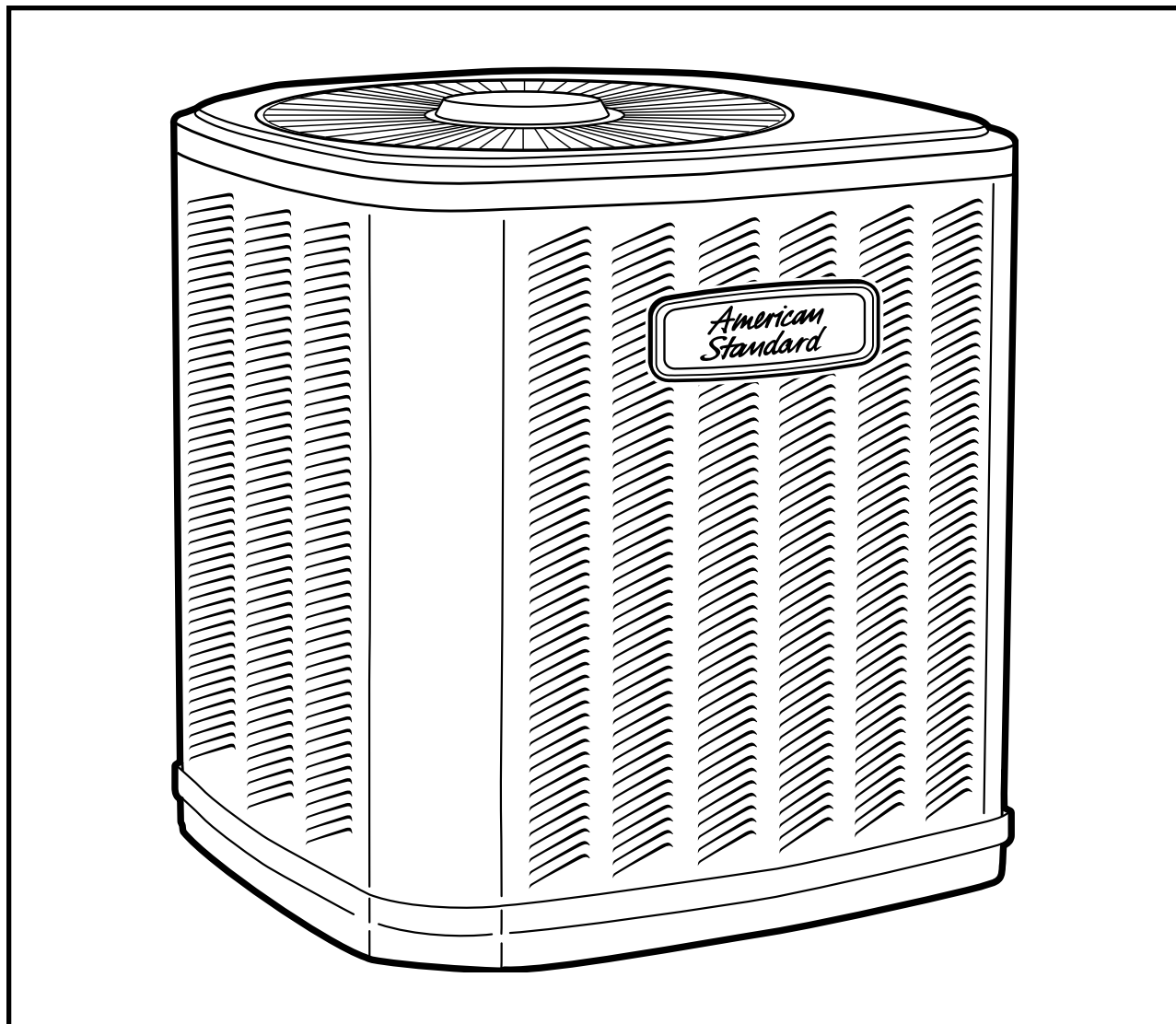

**13 SEER MODELS
2A6B3018-060A**

Features and Benefits

- ◆ **Duration™** compressor
- ◆ All aluminum **Spine Fin™** coil
- ◆ Polyslate gray cabinet
- ◆ **DuraBase™** base pan won't rust, drains completely
- ◆ **Easy-Sess™** service access and refrigerant connections with full coil protection
- ◆ Corrosion resistant finish and fasteners
- ◆ Internal high/low pressure and temperature protection
- ◆ Liquid line filter drier
- ◆ Easy single side service
- ◆ Demand Defrost Control
- ◆ Compressor Sump Heat all models
- ◆ Easy top and fan removal
- ◆ R-22 refrigerant
- ◆ **5 Year limited warranty on compressor, coil, and 5 years on parts (Residential use)**
- ◆ **Extended warranties available**
- ◆ S.E.E.T. design testing
- ◆ 100% line run test
- ◆ Low ambient cooling to 55°F as shipped
- ◆ Low ambient cooling to 40°F with EDC accessory AY28X084
- ◆ Low ambient cooling to 30°F with EDC accessory AY28X084 and TXV

Contents

Manufacturing Control

American Standard Heating & Air Conditioning's exclusive control over the design and manufacturing of all major components is unique in the industry. This approach assures us total control over both the quality and reliability of these components. It also allows us to custom match components to deliver the best in split system performance.

Designing the Details

Careful attention was given to designing the details — from control wiring to the access panels. American Standard Heating & Air Conditioning units feature time-saving color-coded wiring and removable panels which allow complete access to all major components and controls. All outdoor units feature external high and low pressure gauge ports for easy diagnosing and servicing of the unit.

UL Listed

American Standard Heating & Air Conditioning meets or exceeds all nationally recognized agency safety and design standards. Each condensing unit is UL designed, approved, and labeled in accordance to UL Standards, 1995, including approval for use in Canada. Each unit is rated in accordance with ARI Standard 210/240 and 270.

Features and Benefits	2
General Data	4
Product Specifications	4
A-weighted Sound Power Level [dB(A)]	4
Accessory Description and Usage	5
ARI Standard Capacity Rating Conditions	5
Model Nomenclature	6
Typical Wiring	7
Dimensional Data	9
Mechanical Specifications	10

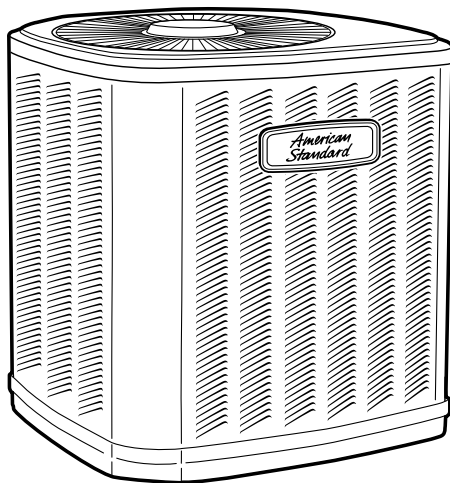

**DATA SUBJECT
TO CHANGE
WITHOUT NOTICE**

PRODUCT DATA

American Standard Heating & Air Conditioning, Tyler, TX 75711-9010

General Data

Product Specifications

Model No. ①	2A6B3018A1	2A6B3024A1	2A6B3030A1	2A6B3036A1
Electrical Data V/Ph/Hz ②	200/230/1/60	200/230/1/60	200/230/1/60	200/230/1/60
Min Cir Ampacity	8	12	13	19
Max Fuse Size (Amps)	15	20	20	30
Compressor	DURATION™	DURATION™	DURATION™	DURATION™
RL Amps - LR Amps	5.9 - 38.6	8.7 - 57.8	9.5 - 63	14.1 - 90.8
Outdoor Fan FL Amps	0.6	1.3	0.9	1.4
Fan HP	1/15	1/4	1/8	1/6
Fan Dia (inches)	19.0	19.0	23.0	27.6
Coil	Spine Fin™	Spine Fin™	Spine Fin™	Spine Fin™
Refrigerant R-22	5/10-LB/OZ	5/11-LB/OZ	6/07-LB/OZ	7/06-LB/OZ
Line Size - (in.) O.D. Gas ③	5/8	3/4	3/4	7/8
Line Size - (in.) O.D. Liquid ③	1/4	5/16	5/16	3/8
Dimensions H x W x D (Crated)	37.2 x 26.7 x 30	37.2 x 26.7 x 30	42 x 30.1 x 33	42.4 x 35.1 x 38.7
Weight - Shipping	201	204	239	297
Weight - Net	181	183	211	263
Start Components	YES	YES	YES	YES
Sound Enclosure	NO	NO	NO	YES
Compressor Sump Heat	YES	YES	YES	YES

Optional Accessories: ④

	2A6B3018A1	2A6B3024A1	2A6B3030A1	2A6B3036A1
Anti-short Cycle Timer	TAYASCT501A	TAYASCT501A	TAYASCT501A	TAYASCT501A
Evaporator Defrost Control A/C	AY28X084	AY28X084	AY28X084	AY28X084
Rubber Isolator Kit	BAYISLT101	BAYISLT101	BAYISLT101	BAYISLT101
Snow Leg - Base & Cap 4" High	BAYLEGS002	BAYLEGS002	BAYLEGS002	BAYLEGS002
Snow Leg - 4" Extension	BAYLEGS003	BAYLEGS003	BAYLEGS003	BAYLEGS003
Extreme Condition Mounting Kit	BAYECMT023	BAYECMT023	BAYECMT023	BAYECMT004
Seacoast Kit	BAYSEAC001	BAYSEAC001	BAYSEAC001	BAYSEAC001
Refrigerant Lineset ⑤	TAYREFLN1*	TAYREFLN2*	TAYREFLN2*	TAYREFLN3*

① Certified in accordance with the Air-Source Unitary Heat Pump Equipment certification program which is based on ARI Standard 210/240.

② Calculated in accordance with N.E.C. Use only HACR circuit breakers or fuses.

③ Standard line lengths - 60' Standard lift - 60' Suction and Liquid line.

For Greater lengths and lifts refer to refrigerant piping software Pub# 32-3312-0t. (*denotes latest revision)

④ For accessory description and usage, see page 5.

⑤ * = 15, 20, 25, 30, 40 and 50 foot lineset available.

A-weighted Sound Power Level [dB(A)]

MODEL	SOUND POWER LEVEL [dB(A)]	A-WEIGHTED FULL OCTAVE SOUND POWER LEVEL dB - [dB(A)]							
		63	125	250	500	1000	2000	4000	8000
2A6B3018A1	74	43.5	52.1	57.0	65.5	67.3	66.8	62.1	55.4
2A6B3024A1	79	51.3	56.1	61.7	71.5	73.1	71.8	64.3	55.8
2A6B3030A1	79	43.8	58.8	62.2	69.2	72.1	71.4	62.5	56.8
2A6B3036A1	79	47.1	60.4	67.8	73.5	73.7	71.6	63.8	51.4
2A6B3042A1	80	48.6	59.9	66.9	73.0	75.2	70.3	64.4	55.2
2A6B3048A1	78	45.4	58.8	66.1	72.5	72.5	69.8	63.0	52.5
2A6B3060A1	79	46.7	55.2	66.5	73.5	73.8	71.8	65.8	56.7

Note: Tested in accordance with ARI Standard 270.95. (Not listed with ARI)

General Data

Product Specifications

Model No. ①	2A6B3042A1	2A6B3048A1	2A6B3060A1
Electrical Data V/Ph/Hz ②	200/230/1/60	200/230/1/60	208/230/1/60
Min Cir Ampacity	21	25	32
Max Fuse Size (Amps)	35	40	50
Compressor	DURATION™	DURATION™	DURATION™ - SCROLL
RL Amps - LR Amps	15.4 - 93.5	18.6 - 93.4	25.0 - 148
Outdoor Fan FL Amps	1.4	1.4	1.2
Fan HP	1/6	1/5	1/5
Fan Dia (inches)	27.6	27.6	27.6
Coil	Spine Fin™	Spine Fin™	Spine Fin™
Refrigerant R-22	9/09-LB/OZ	9/09-LB/OZ	9/08-LB/OZ
Line Size - (in.) O.D. Gas ③	7/8	1-1/8	1-1/8
Line Size - (in.) O.D. Liquid ③	3/8	3/8	3/8
Dimensions H x W x D (Crated)	46.4 x 35.1 x 38.7	46.4 x 35.1 x 38.7	46.4 x 35.1 x 38.7
Weight - Shipping	312	313	314
Weight - Net	277	278	278
Start Components	YES	YES	YES
Sound Enclosure	YES	YES	NO
Compressor Sump Heat	YES	YES	YES
Optional Accessories: ④			
Anti-short Cycle Timer	TAYASCT501A	TAYASCT501A	TAYASCT501A
Evaporator Defrost Control A/C	AY28X084	AY28X084	AY28X084
Rubber Isolator Kit	BAYISLT101	BAYISLT101	BAYISLT101
Snow Leg - Base & Cap 4" High	BAYLEGS002	BAYLEGS002	BAYLEGS002
Snow Leg - 4" Extension	BAYLEGS003	BAYLEGS003	BAYLEGS003
Extreme Condition Mounting Kit	BAYECMT004	BAYECMT004	BAYECMT004
Seacoast Kit	BAYSEAC001	BAYSEAC001	BAYSEAC001
Refrigerant Lineset ⑤	TAYREFLN3*	TAYREFLN4*	TAYREFLN4*

Accessory Description and Usage

Anti-Short Cycle Timer — Solid state timing device that prevents compressor recycling until 5 minutes have elapsed after satisfying call or power interruptions. Use in area with questionable power delivery, commercial applications, long lineset, etc.

Evaporator Defrost Control — SPST Temperature actuated switch that cycles the condenser off as indoor coil reaches freeze-up conditions. Used for low ambient cooling to 30°F with TXV.

Rubber Isolators — 5 large rubber donuts to isolate condensing unit from transmitting energy into mounting frame or pad. Use on any application where sound transmission needs to be minimized.

Hard Start Kit — Start capacitor and relay to assist compressor motor startup. Use in areas with marginal power supply, on long linesets, low ambient conditions, etc.

Extreme Condition Mount Kit — Bracket kits to securely mount condensing unit to a frame or pad without removing any panels. Use in areas with high winds, or on commercial roof tops, etc.

ARI Standard Capacity Rating Conditions

ARI STANDARD 210/240 RATING CONDITIONS —

- (A) Cooling 80°F DB, 67°F WB air entering indoor coil, 95°F DB air entering outdoor coil.
- (B) High Temperature Heating 47°F DB, 43°F WB air entering outdoor coil, 70°F DB air entering indoor coil.
- (C) Low Temperature Heating 17°F DB, 15°F WB air entering outdoor coil, 70°F DB air entering indoor coil.
- (D) Rated indoor airflow for heating is the same as for cooling.

ARI STANDARD 270 RATING CONDITIONS — (Noise rating numbers are determined with the unit in cooling operation.) Standard Noise Rating number is at 95°F outdoor air.



PRODUCT DATA

American Standard Heating & Air Conditioning, Tyler, TX 75711-9010

Model Nomenclature

Outdoor Units

- Refrigerant Type
2 = R-22
4 = R-410A
- AMERICAN STANDARD
- Product Type
6 = Split Heat Pump
7 = Split Cooling
- Product Family
A = Allegiance
H = Heritage
B = Basic
C = Light Commercial
- Family SEER
0 = 10 3 = 13 6 = 16
1 = 11 4 = 14 8 = 18
2 = 12 5 = 15 9 = 19
- Split System Connections 1-6 Tons
0 = Brazed
- Nominal Capacity in 000s of BTUs
- Major Design Modifications
- Power Supply
1 = 200-230/1/60 or 208-230/1/60
3 = 200-230/3/60
4 = 460/3/60
- Secondary Function
- Minor Design Modifications
- Unit Parts Identifier

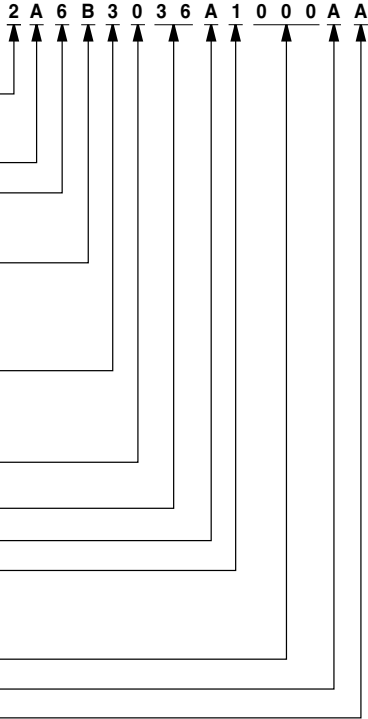

High Efficiency Furnaces

- Furnace Configuration
AU = Upflow / Horizontal
AD = Downflow / Horizontal
- Type
D = 80% Premium
X = 90% Premium
- Number of Heating Stages
1 = Single Stage
2 = Two Stage
3 = Three Stage
- Cabinet Width
A = 14.5" Cabinet Width
B = 17.5" Cabinet Width
C = 21.0" Cabinet Width
D = 24.5" Cabinet Width
- Heating Input
080 = 80,000 BTUH
- Major Design Change
- Power Supply / Fuel
9 = 115 Volts / Natural Gas
- Airflow Capacity for Cooling
36 = 3 Ton Standard PSC Motor
H3 = 3 Ton High Efficiency Motor
V3 = 3 Ton Variable Speed Motor
- Draft Inducer Speeds
1 = Single Speed
2 = Two Speed
V = Variable Speed
- Minor Design Change
- Service Digit - Not Orderable

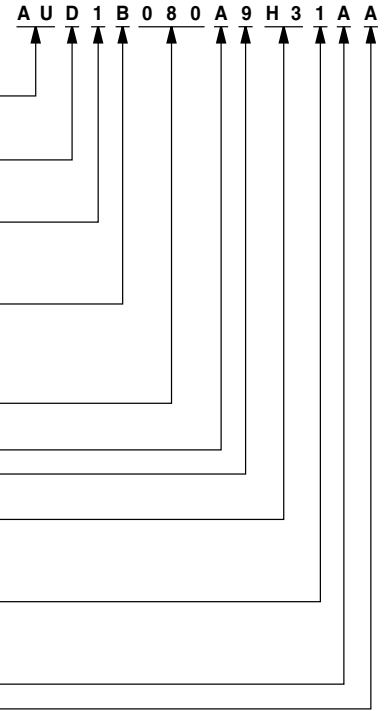

Air Handlers - Residential

- Refrigerant Type
4 = R-410A
2 = R-22
- Application
TE = Fully Convertible
TG = Semi Convertible
TF = Front Return
TV = Vertical
- Product Family
E = Leadership - Variable Speed
P = Leadership
C = Replacement/Retail
B = Basic
- Flow Control
3 = Nonbleed TXV
4 = FCCV*
- Feature Identifier
0 = Standard Unit
F = Air-Tite™
- Nominal Capacity in 000s of BTUs
- Major Design Modifications
- Power Supply
1 = Single Phase
- Electrical Connection
0 = Pig Tails
B = Circuit Breaker
D = Pull Disconnect
- Future Option - Factory Installed Heater Nominal KW Value
- Minor Design Modifications
- Unit Parts Identifier

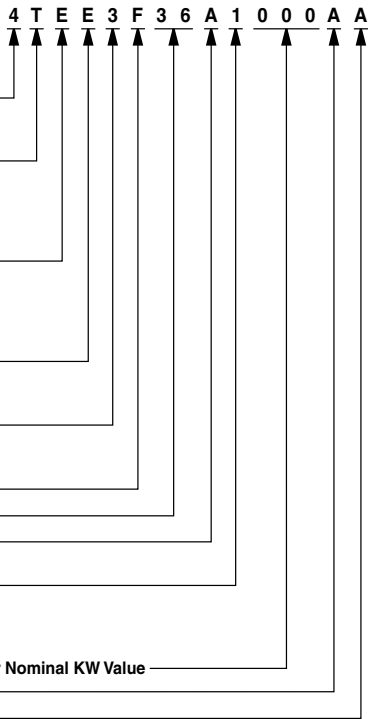

Heat Pump / Cooling Coils

- Refrigerant Type
2 = R-22 4 = R-410A
- Product Family
T = Premium (Heat Pump or Convertible Coil)
C = Standard (Cooling Only)
- Coil Design
X = Direct Expansion Evaporator Coil
- Product Family
C = Cased A Coil
A = Uncased A Coil
F = Cased Horizontal Flat Coil
- Coil Width (Cased / Uncased)
A = 14.5" / 13.3" C = 21.0" / 19.8" H = 10.5"
B = 17.5" / 16.3" D = 24.5" / 23.3"
- Refrigerant Line Coupling
0 = Brazed
- Nominal Capacity in 000s of BTUs
- Major Design Change
- Efficiency
C = Standard S = Hi Efficiency
- Refrigerant Control
3 = TXV - Non-Bleed
- Coil Circuitry
H = Heat Pump
C = Cooling Only
- Airflow Configuration
A = Upflow Only
U = Upflow / Downflow
H = Horizontal Only
C = Convertible - Upflow, Downflow, Left Airflow
M = Convertible - Upflow, Downflow, Left or Right Airflow
- Minor Design Change
- Unit Parts Identifier

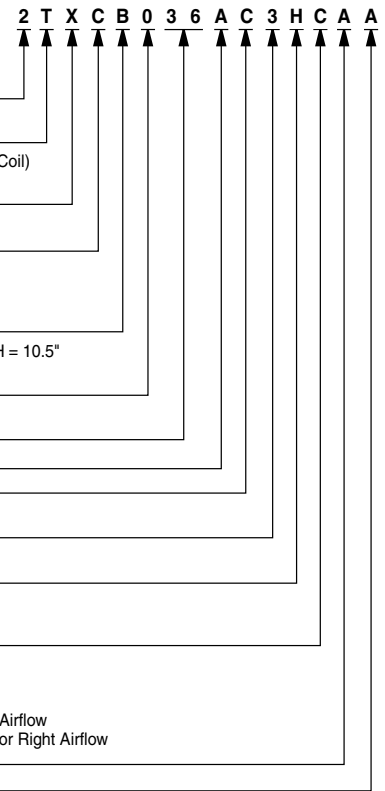

NOTE: There will be a phase-in of new model numbers for new air handlers over next 2 years.
*Shipped with R-22 FCCV

Typical Wiring

SCHEMATIC DIAGRAMS

(SEE LEGEND)

2A6B3018,024,030,036,042A

2A6B3048A

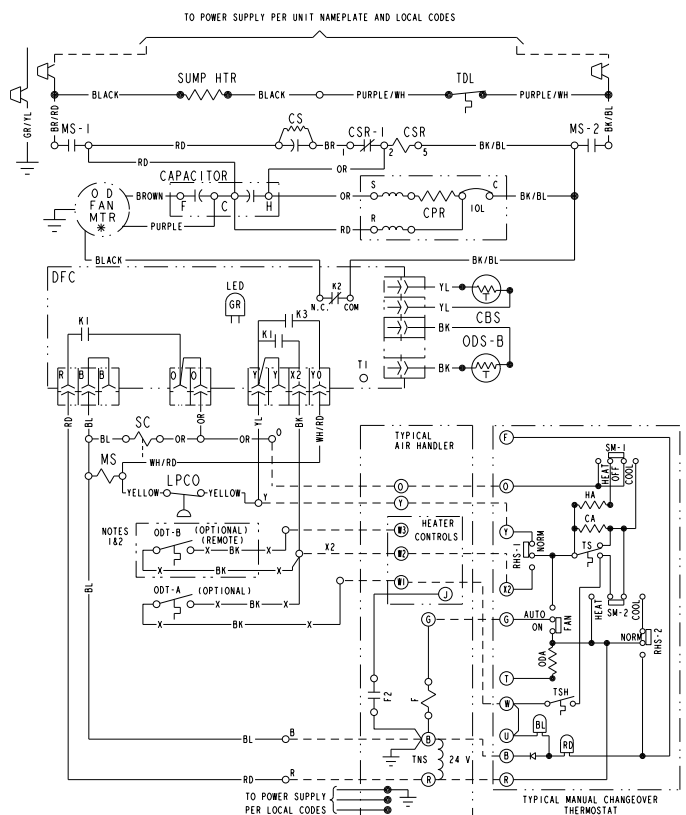
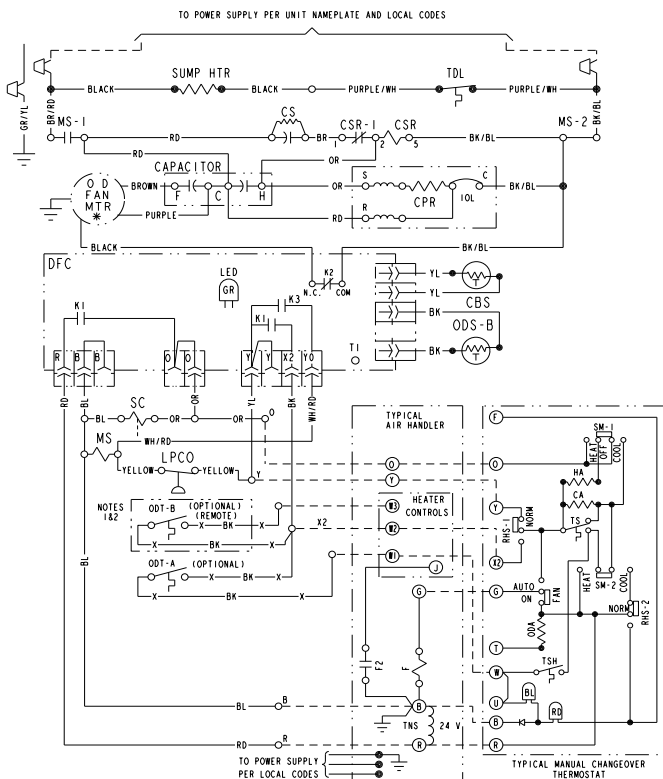

NOTES:

1. IF ODT-B IS NOT USED, ADD JUMPER BETWEEN W2 & W3 AT AIR HANDLER. IF USED, ODT-B MUST BE MOUNTED REMOTE OF CONTROL BOX IN AN APPROVED WEATHER PROOF ENCLOSURE.
2. IF ODT-A IS NOT USED, ADD JUMPER BETWEEN W1 & W2 AT AIR HANDLER.
3. LOW VOLTAGE (24 V.) FIELD WIRING MUST BE 18 AWG MIN.

NOTES:

1. IF ODT-B IS NOT USED, ADD JUMPER BETWEEN W2 & W3 AT AIR HANDLER. IF USED, ODT-B MUST BE MOUNTED REMOTE OF CONTROL BOX IN AN APPROVED WEATHER PROOF ENCLOSURE.
2. IF ODT-A IS NOT USED, ADD JUMPER BETWEEN W1 & W2 AT AIR HANDLER.
3. LOW VOLTAGE (24 V.) FIELD WIRING MUST BE 18 AWG MIN.

<p>⚠ WARNING HAZARDOUS VOLTAGE! DISCONNECT ALL ELECTRIC POWER INCLUDING REMOTE DISCONNECTS BEFORE SERVICING. FAILURE TO DISCONNECT POWER BEFORE SERVICING CAN CAUSE SEVERE PERSONAL INJURY OR DEATH!</p>	<p>⚠ CAUTION USE COPPER CONDUCTORS ONLY! UNIT TERMINALS ARE NOT DESIGNED TO ACCEPT OTHER TYPES OF CONDUCTORS. FAILURE TO DO SO MAY CAUSE DAMAGE TO THE EQUIPMENT!</p>
---	--

<p>⚠ WARNING HAZARDOUS VOLTAGE! DISCONNECT ALL ELECTRIC POWER INCLUDING REMOTE DISCONNECTS BEFORE SERVICING. FAILURE TO DISCONNECT POWER BEFORE SERVICING CAN CAUSE SEVERE PERSONAL INJURY OR DEATH!</p>	<p>⚠ CAUTION USE COPPER CONDUCTORS ONLY! UNIT TERMINALS ARE NOT DESIGNED TO ACCEPT OTHER TYPES OF CONDUCTORS. FAILURE TO DO SO MAY CAUSE DAMAGE TO THE EQUIPMENT!</p>
---	--

FOR CANADIAN INSTALLATIONS
POUR INSTALLATIONS CANADIENNES
**CAUTION: NOT SUITABLE FOR USE ON SYSTEMS EXCEEDING 150V-TO-GROUND.
ATTENTION: NE CONVIENT PAS AUX INSTALLATIONS DE PLUS DE 150 V A LA TERRE.**

FOR CANADIAN INSTALLATIONS
POUR INSTALLATIONS CANADIENNES
**CAUTION: NOT SUITABLE FOR USE ON SYSTEMS EXCEEDING 150V-TO-GROUND.
ATTENTION: NE CONVIENT PAS AUX INSTALLATIONS DE PLUS DE 150 V A LA TERRE.**

Printed from D155595P01

Printed from D155596P01

Dimensional Data

2A6B3 OUTLINE DRAWING NOTE: ALL DIMENSIONS ARE IN MM (INCHES).

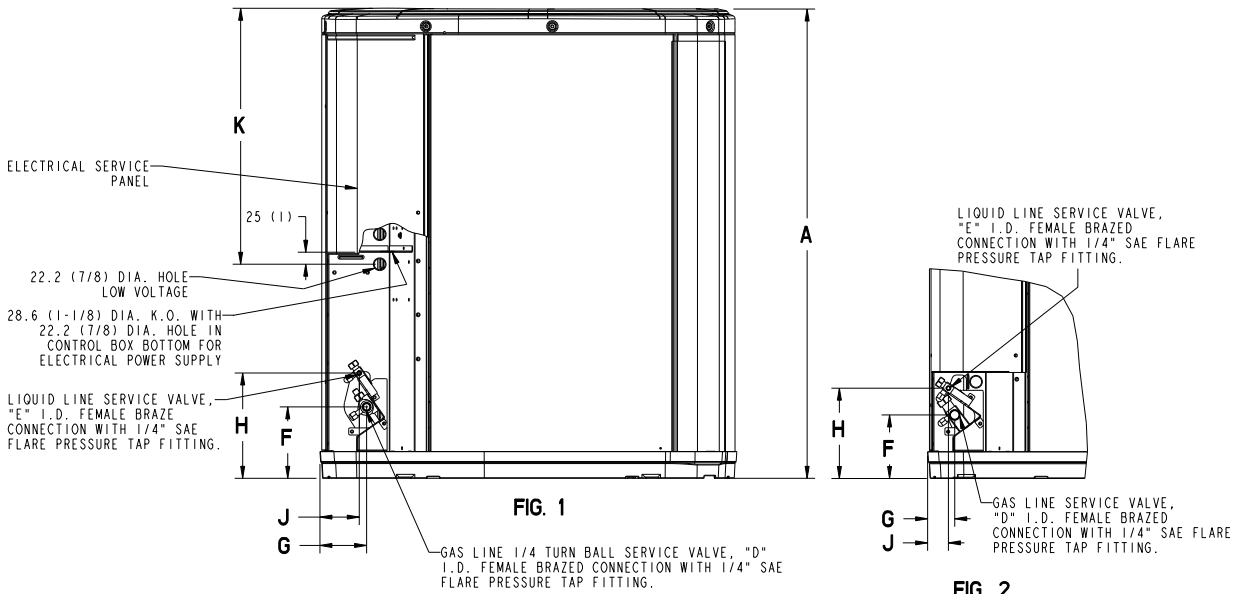
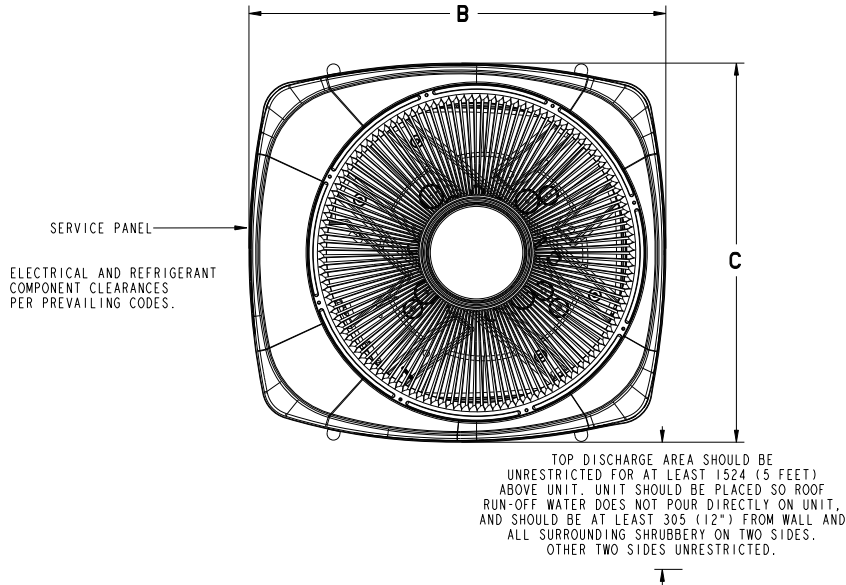

MODELS	BASE	FIG.	A	B	C	D	E	F	G	H	J	K
2A6B3018A	2	2	832 (32-3/4)	724 (28-1/2)	651 (25-5/8)	5/8	1/4	127 (5)	57 (2-1/4)	181 (7-1/8)	44 (1-3/4)	457 (18)
2A6B3024A	2	1	832 (32-3/4)	724 (28-1/2)	651 (25-5/8)	3/4	5/16	137 (5-3/8)	65 (2-5/8)	210 (8-1/4)	57 (2-1/4)	457 (18)
2A6B3030A	3	1	933 (36-3/4)	829 (32-5/8)	756 (29-3/4)	3/4	5/16	143 (5-5/8)	92 (3-5/8)	210 (8-1/4)	79 (3-1/8)	508 (20)
2A6B3036A	4	1	943 (37-1/8)	946 (37-1/4)	870 (34-1/4)	7/8	3/8	152 (6)	98 (3-7/8)	219 (8-5/8)	86 (3-3/8)	508 (20)
2A6B3042A	4	1	1045 (41-1/8)	946 (37-1/4)	870 (34-1/4)	7/8	3/8	152 (6)	98 (3-7/8)	219 (8-5/8)	86 (3-3/8)	508 (20)
2A6B3048A	4	1	1045 (41-1/8)	946 (37-1/4)	870 (34-1/4)	1-1/8	3/8	152 (6)	98 (3-7/8)	219 (8-5/8)	86 (3-3/8)	508 (20)
2A6B3060A	4	1	1045 (41-1/8)	946 (37-1/4)	870 (34-1/4)	1-1/8	3/8	152 (6)	98 (3-7/8)	219 (8-5/8)	86 (3-3/8)	508 (20)

From Dwg. D153074 Rev. 10

PRODUCT DATA

American Standard Heating & Air Conditioning, Tyler, TX 75711-9010

Mechanical Specifications

General

These models shall be fully charged from the factory for matched indoor section and up to 15 feet of piping. This unit must be designed to operate at outdoor ambient temperatures as high as 115°F. Cooling capacities shall be matched with a wide selection of air handlers and furnace coils that are ARI certified. The unit shall be UL listed. Exterior must be designed for outdoor application.

Casing

Unit casing is constructed of heavy gauge, galvanized steel and painted with a weather-resistant powder paint finish on all louvered panels. Corrosion and weatherproof CMBP-G30 DuraBase™ base.

Refrigerant Controls

Refrigeration system controls include condenser fan and compressor contactor. High and low pressure controls are inherent to the compressor. Unit also has low pressure switch. Another standard feature is the liquid line drier.

Compressor

The Duration™ compressor features internal over temperature and pressure protector, dipped hermetic motor and sump heater. Other features include: roto lock suction and discharge refrigerant connections, centrifugal oil pump, and low vibration and noise. The Duration™ compressor features a 5-year limited warranty.

Condenser Coil

The Spine Fin™ coil shall be continuously wrapped, corrosion resistant all aluminum with minimum brazed joints. This coil is seamless aluminum glued to a continuous aluminum fin. Coils are lab tested to withstand 2,000 pounds of pressure per square inch.

Low Ambient Cooling

As shipped, this unit has a cooling capability to 55°F. The addition of an evaporator defrost control permits operation to 40°F. The addition of an evaporator defrost control with TXV permits low ambient cooling to 30°F.

Accessories

Thermostats — Heat/cooling (manual and automatic changeover). Subbase to match thermostat and locking thermostat cover.

Evaporator Defrost Control — See Low Ambient Cooling.

Outdoor Thermostat — Supplemental heat outdoor ambient lockout from 46 to -10°F.

Since the manufacturer has a policy of continuous product and product data improvement, it reserves the right to change design and specifications without notice.

Technical Literature - Printed in U.S.A.

American Standard
Heating & Air Conditioning
Troup Highway
Tyler, TX 75711-9010