

HERITAGE® 13
MODELS 4A6H3018-060A

Features and Benefits

- ◆ **Duration™** compressor
- ◆ All aluminum **Spine Fin™** coil
- ◆ **Easy-Sess™** service access and refrigerant connections with full coil protection
- ◆ **DuraBase™** base pan won't rust, drains completely
- ◆ **Comfort "R"™** mode approved
- ◆ Polyslate gray cabinet
- ◆ Corrosion resistant finish and fasteners
- ◆ Liquid line filter drier
- ◆ Compressor Sump Heat
- ◆ 018, 024, 030 and 060 ship with Start Kit
- ◆ Internal compressor high/low pressure and temperature protection
- ◆ R-410 refrigerant
- ◆ Low ambient cooling to 55°F as shipped
- ◆ Low ambient cooling to 30°F with EDC accessory AY28X084 and TXV
- ◆ S.E.E.T. design testing
- ◆ 100% line run test
- ◆ Electronic demand defrost control
- ◆ **10 Year limited warranty on compressor, coil, and 5 years on parts (Residential Use)**
- ◆ **Extended warranties available**

Contents

Manufacturing Control

American Standard Heating & Air Conditioning's exclusive control over the design and manufacturing of all major components is unique in the industry. This approach assures us total control over both the quality and reliability of these components. It also allows us to custom match components to deliver the best in split system performance.

Designing the Details

Careful attention was given to designing the details — from control wiring to the access panels. American Standard Heating & Air Conditioning units feature time-saving color-coded wiring and removable panels which allow complete access to all major components and controls. All outdoor units feature external high and low pressure gauge ports for easy diagnosing and servicing of the unit.

UL Listed

American Standard Heating & Air Conditioning meets or exceeds all nationally recognized agency safety and design standards. Each condensing unit is UL designed, approved, and labeled in accordance to UL Standards, 1995, including approval for use in Canada. Each unit is rated in accordance with ARI Standard 210/240 and 270.

Features and Benefits

General Data

Product Specifications

A-weighted Sound

Power Level [dB(A)]

Accessory Description and Usage

ARI Standard Capacity Rating Conditions

Model Nomenclature

Typical Wiring

Dimensional Data

Mechanical Specifications

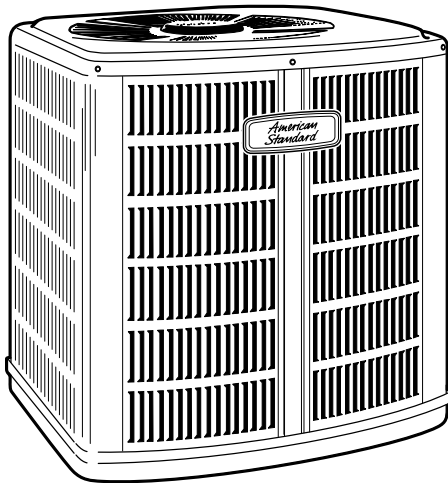

Features and Benefits	2
General Data	4
Product Specifications	4
A-weighted Sound Power Level [dB(A)]	4
Accessory Description and Usage	5
ARI Standard Capacity Rating Conditions	5
Model Nomenclature	6
Typical Wiring	7
Dimensional Data	10
Mechanical Specifications	11

DATA SUBJECT TO CHANGE WITHOUT NOTICE

PRODUCT DATA

American Standard Heating & Air Conditioning, Tyler, TX 75711-9010

General Data

Product Specifications

Model No. ①	4A6H3018A1	4A6H3024A1	4A6H3030A1	4A6H3036A1
Electrical Data V/Ph/Hz ②	200/230/1/60	200/230/1/60	200/230/1/60	208/230/1/60
Min Cir Ampacity	10	12	15	21
Max Fuse Size (Amps)	15	20	25	35
Compressor	DURATION™	DURATION™	DURATION™	DURATION™ - SCROLL
RL Amps - LR Amps	7.7 - 38.6	9.4 - 63	11.7 - 68.2	15.4 - 83
Outdoor Fan FL Amps	0.7	0.7	0.7	1.3
Fan HP	1/8	1/8	1/8	1/4
Fan Dia (inches)	23.0	23.0	23.0	27.6
Coil	Spine Fin™	Spine Fin™	Spine Fin™	Spine Fin™
Refrigerant R-410A	5/12-LB/OZ	5/12-LB/OZ	6/01-LB/OZ	7/15-LB/OZ
Line Size - (in.) O.D. Gas ③	1/2	5/8	3/4	3/4
Line Size - (in.) O.D. Liquid ③	1/4	5/16	5/16	3/8
Charge Spec. Subcooling	10°	11°	11°	10°
Dimensions H x W x D (Crated)	34 x 30.1 x 33	34 x 30.1 x 33	42 x 30.1 x 33	42.4 x 35.1 x 38.7
Weight - Shipping	214	217	231	271
Weight - Net	187	190	203	236
Start Components	YES	YES	YES	NO
Sound Enclosure	YES	YES	YES	NO
Compressor Sump Heat	NO	YES	YES	YES
Optional Accessories: ④				
Anti-short Cycle Timer	TAYASCT501A	TAYASCT501A	TAYASCT501A	TAYASCT501A
Evaporator Defrost Control	AY28X084	AY28X084	AY28X084	AY28X084
Rubber Isolator Kit	BAYISLT101	BAYISLT101	BAYISLT101	BAYISLT101
Snow Leg - Base & Cap 4" High	BAYLEGS002	BAYLEGS002	BAYLEGS002	BAYLEGS002
Snow Leg - 4" Extension	BAYLEGS003	BAYLEGS003	BAYLEGS003	BAYLEGS003
Start Kit				BAYKSKT260
Crankcase Heater Kit	BAYOCHT300			
Seacoast Kit	BAYSEAC001	BAYSEAC001	BAYSEAC001	BAYSEAC001
Low Ambient Kit	BAYLOAM103	BAYLOAM103	BAYLOAM103	BAYLOAM103
Extreme Condition Mounting Kit	BAYECMT023	BAYECMT023	BAYECMT023	BAYECMT004
Refrigerant Lineset ⑤	TAYREFLN5*	TAYREFLN6*	TAYREFLN2*	TAYREFLN7*

① Certified in accordance with the Air-Source Unitary Heat Pump equipment certification program which is based on ARI Standard 210/240.

② Calculated in accordance with N.E.C. Only use HACR circuit breakers or fuses.

③ Standard line lengths - 60' Standard lift - 60' Suction and Liquid line.

For Greater lengths and lifts refer to refrigerant piping software Pub# 32-3312-0*. (*denotes latest revision)

④ For accessory description and usage, see page 5.

⑤ * = 15, 20, 25, 30, 40 and 50 foot lineset available.

A-weighted Sound Power Level [dB(A)]

MODEL	SOUND POWER LEVEL [dB(A)]	A-WEIGHTED FULL OCTAVE SOUND POWER LEVEL dB - [dB(A)]							
		63	125	250	500	1000	2000	4000	8000
4A6H3018A1	76	47.7	61.8	66.1	71.2	70.7	68.2	57.7	49.4
4A6H3024A1	76	45.5	59.9	66.2	70.1	70.6	69.2	61.7	59.6
4A6H3030A1	76	45.3	58.7	65.1	69.3	69.3	66.7	57.9	53.3
4A6H3036A1	75	47.5	57.2	59.1	66.8	68.2	62.9	56.7	52.9
4A6H3042A1	75	48.2	56.2	60.4	66.6	69.3	63.7	57.2	49.3
4A6H3048A1	76	46.3	56.5	66.3	72.9	72.6	68.7	60.3	48.3
4A6H3060A1	76	54.7	54.7	59.9	67.2	70.7	66.7	61.4	52.8

Note: Tested in accordance with ARI Standard 270.95. (Not listed with ARI)

General Data

Product Specifications

Model No. ①	4A6H3042A1	4A6H3048A1	4A6H3060A1
Electrical Data V/Ph/Hz ②	208/230/1/60	208/230/1/60	208/230/1/60
Min Cir Ampacity	25	30	36
Max Fuse Size (Amps)	40	50	60
Compressor	DURATION™ - SCROLL	DURATION™ - SCROLL	DURATION™ - SCROLL
RL Amps - LR Amps	18.6 - 105	23.1 - 134	27.6 - 158
Outdoor Fan FL Amps	1.3	1.3	1.3
Fan HP	1/4	1/4	1/4
Fan Dia (inches)	27.6	27.6	27.6
Coil	Spine Fin™	Spine Fin™	Spine Fin™
Refrigerant R-410A	8/03-LB/OZ	8/10-LB/OZ	9/07-LB/OZ
Line Size - (in.) O.D. Gas ③	3/4	7/8	7/8
Line Size - (in.) O.D. Liquid ③	3/8	3/8	3/8
Charge Spec. Subcooling	10°	10°	13°
Dimensions H x W x D (Crated)	42.4 x 35.1 x 38.7	46.4 x 35.1 x 38.7	46.4 x 35.1 x 38.7
Weight - Shipping	272	285	308
Weight - Net	237	249	272
Start Components	NO	NO	YES
Sound Enclosure	NO	NO	NO
Compressor Sump Heat	YES	YES	YES
Optional Accessories: ④			
Anti-short Cycle Timer	TAYASCT501A	TAYASCT501A	TAYASCT501A
Evaporator Defrost Control	AY28X084	AY28X084	AY28X084
Rubber Isolator Kit	BAYISLT101	BAYISLT101	BAYISLT101
Snow Leg - Base & Cap 4" High	BAYLEGS002	BAYLEGS002	BAYLEGS002
Snow Leg - 4" Extension	BAYLEGS003	BAYLEGS003	BAYLEGS003
Start Kit	BAYKSKT260	BAYKSKT260	
Crankcase Heater Kit			
Seacoast Kit	BAYSEAC001	BAYSEAC001	BAYSEAC001
Low Ambient Kit	BAYLOAM103	BAYLOAM103	BAYLOAM103
Extreme Condition Mounting Kit	BAYECMT004	BAYECMT004	BAYECMT004
Refrigerant Lineset ⑤	TAYREFLN7*	TAYREFLN3*	TAYREFLN3*

Accessory Description and Usage

Anti-Short Cycle Timer — Solid state timing device that prevents compressor recycling until 5 minutes have elapsed after satisfying call or power interruptions. Use in area with questionable power delivery, commercial applications, long lineset, etc.

Evaporator Defrost Control — SPST Temperature actuated switch that cycles the condenser off as indoor coil reaches freeze-up conditions. Used for low ambient cooling to 30°F with TXV.

Rubber Isolators — 5 large rubber donuts to isolate condensing unit from transmitting energy into mounting frame or pad. Use on any application where sound transmission needs to be minimized.

Hard Start Kit — Start capacitor and relay to assist compressor motor startup. Use in areas with marginal power supply, on long linesets, low ambient conditions, etc.

Extreme Condition Mount Kit — Bracket kits to securely mount condensing unit to a frame or pad without removing any panels. Use in areas with high winds, or on commercial roof tops, etc.

ARI Standard Capacity Rating Conditions

ARI STANDARD 210/240 RATING CONDITIONS —

- (A) Cooling 80°F DB, 67°F WB air entering indoor coil, 95°F DB air entering outdoor coil.
- (B) High Temperature Heating 47°F DB, 43°F WB air entering outdoor coil, 70°F DB air entering indoor coil.
- (C) Low Temperature Heating 17°F DB, 15°F WB air entering outdoor coil, 70°F DB air entering indoor coil.
- (D) Rated indoor airflow for heating is the same as for cooling.

ARI STANDARD 270 RATING CONDITIONS — (Noise rating numbers are determined with the unit in cooling operation.) Standard Noise Rating number is at 95°F outdoor air.



ARI Standard
210/240 UHP



PRODUCT DATA

American Standard Heating & Air Conditioning, Tyler, TX 75711-9010

Model Nomenclature

Outdoor Units

- Refrigerant Type
 - 2 = R-22
 - 4 = R-410A
- AMERICAN STANDARD
- Product Type
 - 6 = Split Heat Pump
 - 7 = Split Cooling
- Product Family
 - A = Allegiance
 - H = Heritage
 - B = Basic
 - C = Light Commercial
- Family SEER
 - 0 = 10 3 = 13 6 = 16
 - 1 = 11 4 = 14 8 = 18
 - 2 = 12 5 = 15 9 = 19
- Split System Connections 1-6 Tons
 - 0 = Brazed
- Nominal Capacity in 000s of BTUs
- Major Design Modifications
- Power Supply
 - 1 = 200-230/1/60 or 208-230/1/60
 - 3 = 200-230/3/60
 - 4 = 460/3/60
- Secondary Function
- Minor Design Modifications
- Unit Parts Identifier

4 A 6 H 3 0 3 6 A 1 0 0 0 A A

High Efficiency Furnaces

- Furnace Configuration
 - AU = Upflow / Horizontal
 - AD = Downflow / Horizontal
- Type
 - D = 80% Premium
 - X = 90% Premium
- Number of Heating Stages
 - 1 = Single Stage
 - 2 = Two Stage
 - 3 = Three Stage
- Cabinet Width
 - A = 14.5" Cabinet Width
 - B = 17.5" Cabinet Width
 - C = 21.0" Cabinet Width
 - D = 24.5" Cabinet Width
- Heating Input
 - 080 = 80,000 BTUH
- Major Design Change
- Power Supply / Fuel
 - 9 = 115 Volts / Natural Gas
- Airflow Capacity for Cooling
 - 36 = 3 Ton Standard PSC Motor
 - H3 = 3 Ton High Efficiency Motor
 - V3 = 3 Ton Variable Speed Motor
- Draft Inducer Speeds
 - 1 = Single Speed
 - 2 = Two Speed
 - V = Variable Speed
- Minor Design Change
- Service Digit - Not Orderable

A U D 1 B 0 8 0 A 9 H 3 1 A A

Air Handlers - Residential

- Refrigerant Type
 - 4 = R-410A
 - 2 = R-22
- Application
 - TE = Fully Convertible
 - TG = Semi Convertible
 - TF = Front Return
 - TV = Vertical
- Product Family
 - E = Leadership - Variable Speed
 - P = Leadership
 - C = Replacement/Retail
 - B = Basic
- Flow Control
 - 3 = Nonbleed TXV
 - 4 = FCCV*
- Feature Identifier
 - 0 = Standard Unit
 - F = Air-Tite™
- Nominal Capacity in 000s of BTUs
- Major Design Modifications
- Power Supply
 - 1 = Single Phase
- Electrical Connection
 - 0 = Pig Tails
 - B = Circuit Breaker
 - D = Pull Disconnect
- Future Option - Factory Installed Heater Nominal KW Value
- Minor Design Modifications
- Unit Parts Identifier

4 T E E 3 F 3 6 A 1 0 0 0 A A

Heat Pump / Cooling Coils

- Refrigerant Type
 - 2 = R-22
 - 4 = R-410A
- Product Family
 - T = Premium (Heat Pump or Convertible Coil)
 - C = Standard (Cooling Only)
- Coil Design
 - X = Direct Expansion Evaporator Coil
- Product Family
 - C = Cased A Coil
 - A = Uncased A Coil
 - F = Cased Horizontal Flat Coil
- Coil Width (Cased / Uncased)
 - A = 14.5" / 13.3" C = 21.0" / 19.8" H = 10.5"
 - B = 17.5" / 16.3" D = 24.5" / 23.3"
- Refrigerant Line Coupling
 - 0 = Brazed
- Nominal Capacity in 000s of BTUs
- Major Design Change
- Efficiency
 - C = Standard S = Hi Efficiency
- Refrigerant Control
 - 3 = TXV - Non-Bleed
- Coil Circuitry
 - H = Heat Pump
 - C = Cooling Only
- Airflow Configuration
 - A = Upflow Only
 - U = Upflow / Downflow
 - H = Horizontal Only
 - C = Convertible - Upflow, Downflow, Left Airflow
 - M = Convertible - Upflow, Downflow, Left or Right Airflow
- Minor Design Change
- Unit Parts Identifier

2 T X C B 0 3 6 A C 3 H C A A

NOTE: There will be a phase-in of new model numbers for new air handlers over next 2 years.
*Shipped with R-22 FCCV

Typical Wiring

SCHEMATIC DIAGRAMS

(SEE LEGEND)

4A6H3018A

TO POWER SUPPLY PER UNIT NAMEPLATE AND LOCAL CODES

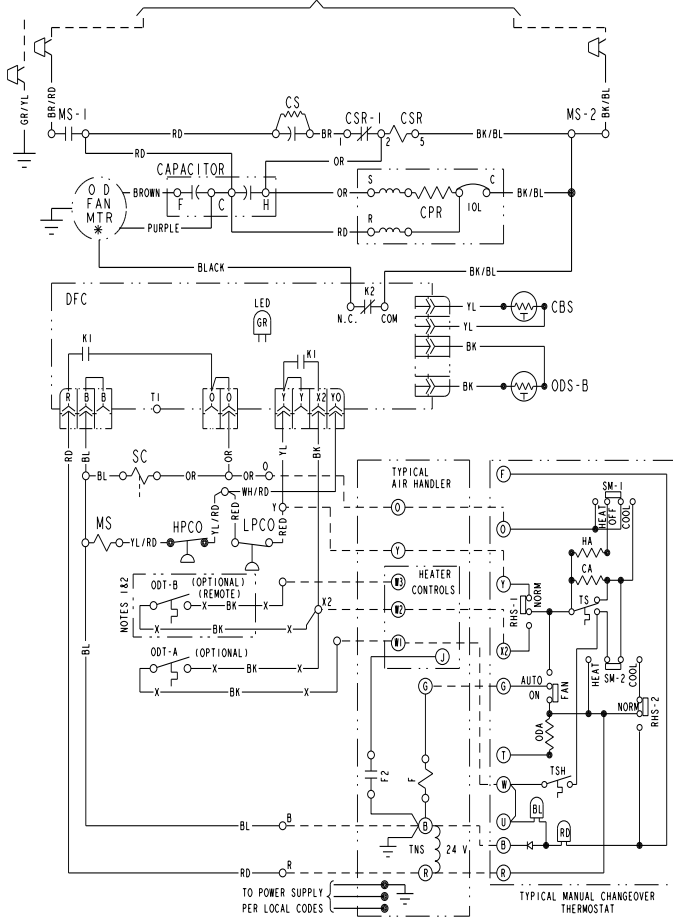

NOTES:

1. IF ODT-B IS NOT USED, ADD JUMPER BETWEEN W2 & W3 AT AIR HANDLER. IF USED, ODT-B MUST BE MOUNTED REMOTE OF CONTROL BOX IN AN APPROVED WEATHER PROOF ENCLOSURE.
2. IF ODT-A IS NOT USED, ADD JUMPER BETWEEN W1 & W2 AT AIR HANDLER.
3. LOW VOLTAGE (24 V.) FIELD WIRING MUST BE 18 AWG MIN.

<p>⚠ WARNING HAZARDOUS VOLTAGE! DISCONNECT ALL ELECTRIC POWER INCLUDING REMOTE DISCONNECTS BEFORE SERVICING. FAILURE TO DISCONNECT POWER BEFORE SERVICING CAN CAUSE SEVERE PERSONAL INJURY OR DEATH!</p>	<p>⚠ CAUTION USE COPPER CONDUCTORS ONLY! UNIT TERMINALS ARE NOT DESIGNED TO ACCEPT OTHER TYPES OF CONDUCTORS. FAILURE TO DO SO MAY CAUSE DAMAGE TO THE EQUIPMENT!</p>
---	--

FOR CANADIAN INSTALLATIONS
POUR INSTALLATIONS CANADIENNES
CAUTION: NOT SUITABLE FOR USE ON SYSTEMS EXCEEDING 150V-TO-GROUND.
ATTENTION: NE CONVIENT PAS AUX INSTALLATIONS DE PLUS DE 150 V A LA TERRE.

Printed from D155589REV00

4A6H3024,030A

TO POWER SUPPLY PER UNIT NAMEPLATE AND LOCAL CODES

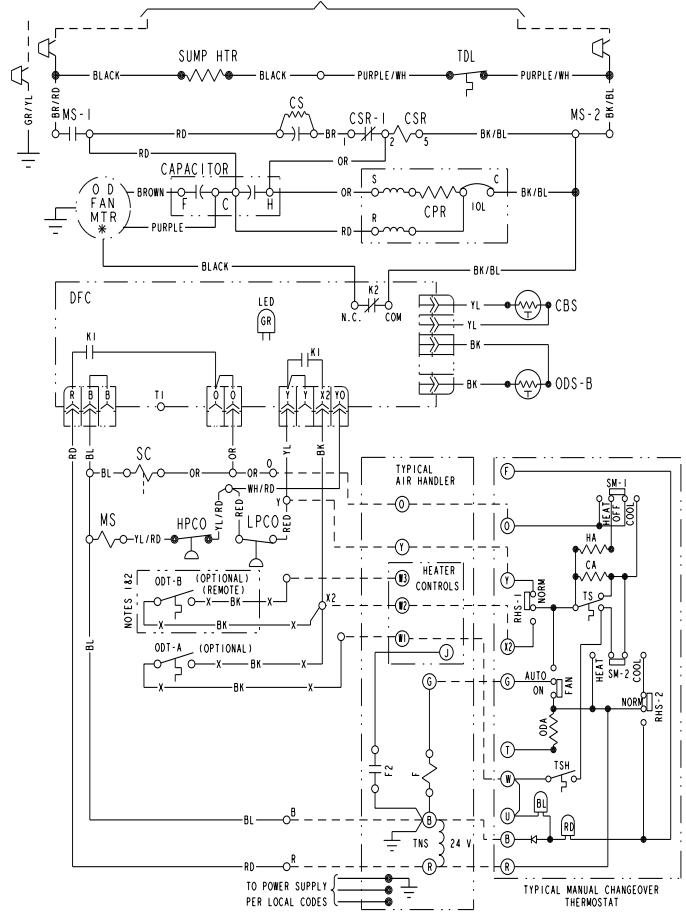

NOTES:

1. IF ODT-B IS NOT USED, ADD JUMPER BETWEEN W2 & W3 AT AIR HANDLER. IF USED, ODT-B MUST BE MOUNTED REMOTE OF CONTROL BOX IN AN APPROVED WEATHER PROOF ENCLOSURE.
2. IF ODT-A IS NOT USED, ADD JUMPER BETWEEN W1 & W2 AT AIR HANDLER.
3. LOW VOLTAGE (24 V.) FIELD WIRING MUST BE 18 AWG MIN.

<p>⚠ WARNING HAZARDOUS VOLTAGE! DISCONNECT ALL ELECTRIC POWER INCLUDING REMOTE DISCONNECTS BEFORE SERVICING. FAILURE TO DISCONNECT POWER BEFORE SERVICING CAN CAUSE SEVERE PERSONAL INJURY OR DEATH!</p>	<p>⚠ CAUTION USE COPPER CONDUCTORS ONLY! UNIT TERMINALS ARE NOT DESIGNED TO ACCEPT OTHER TYPES OF CONDUCTORS. FAILURE TO DO SO MAY CAUSE DAMAGE TO THE EQUIPMENT!</p>
---	--

FOR CANADIAN INSTALLATIONS
POUR INSTALLATIONS CANADIENNES
CAUTION: NOT SUITABLE FOR USE ON SYSTEMS EXCEEDING 150V-TO-GROUND.
ATTENTION: NE CONVIENT PAS AUX INSTALLATIONS DE PLUS DE 150 V A LA TERRE.

Printed from D155590REV00

PRODUCT DATA

American Standard Heating & Air Conditioning, Tyler, TX 75711-9010

Typical Wiring

SCHEMATIC DIAGRAMS (SEE LEGEND)

4A6H3036,042A

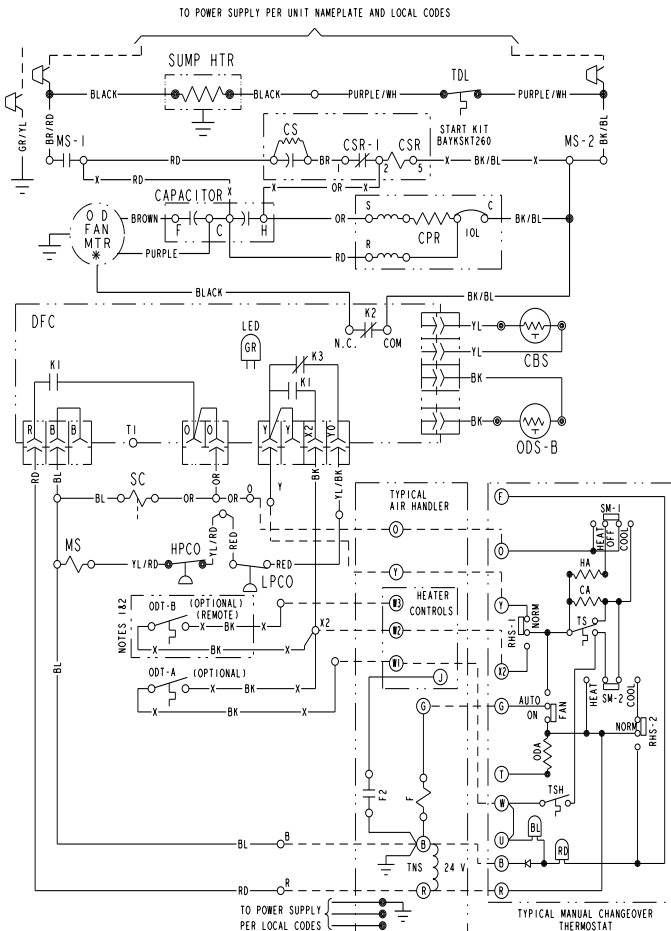

NOTES:

1. IF ODT-B IS NOT USED, ADD JUMPER BETWEEN W2 & W3 AT AIR HANDLER.
IF USED, ODT-B MUST BE MOUNTED REMOTE OF CONTROL BOX IN AN APPROVED WEATHER PROOF ENCLOSURE.
2. IF ODT-A IS NOT USED, ADD JUMPER BETWEEN W1 & W2 AT AIR HANDLER.
3. LOW VOLTAGE (24 V.) FIELD WIRING MUST BE 18 AWG MIN.

<p>⚠ WARNING HAZARDOUS VOLTAGE! DISCONNECT ALL ELECTRIC POWER INCLUDING REMOTE DISCONNECTS BEFORE SERVICING. FAILURE TO DISCONNECT POWER BEFORE SERVICING CAN CAUSE SEVERE PERSONAL INJURY OR DEATH!</p>	<p>⚠ CAUTION USE COPPER CONDUCTORS ONLY! UNIT TERMINALS ARE NOT DESIGNED TO ACCEPT OTHER TYPES OF CONDUCTORS. FAILURE TO DO SO MAY CAUSE DAMAGE TO THE EQUIPMENT!</p>
---	--

FOR CANADIAN INSTALLATIONS
POUR INSTALLATIONS CANADIENNES

CAUTION: NOT SUITABLE FOR USE ON SYSTEMS EXCEEDING 150V-TO-GROUND.
ATTENTION: NE CONVIENT PAS AUX INSTALLATIONS DE PLUS DE 150 V A LA TERRE.

Printed from D155591REV00

4A6H3048A

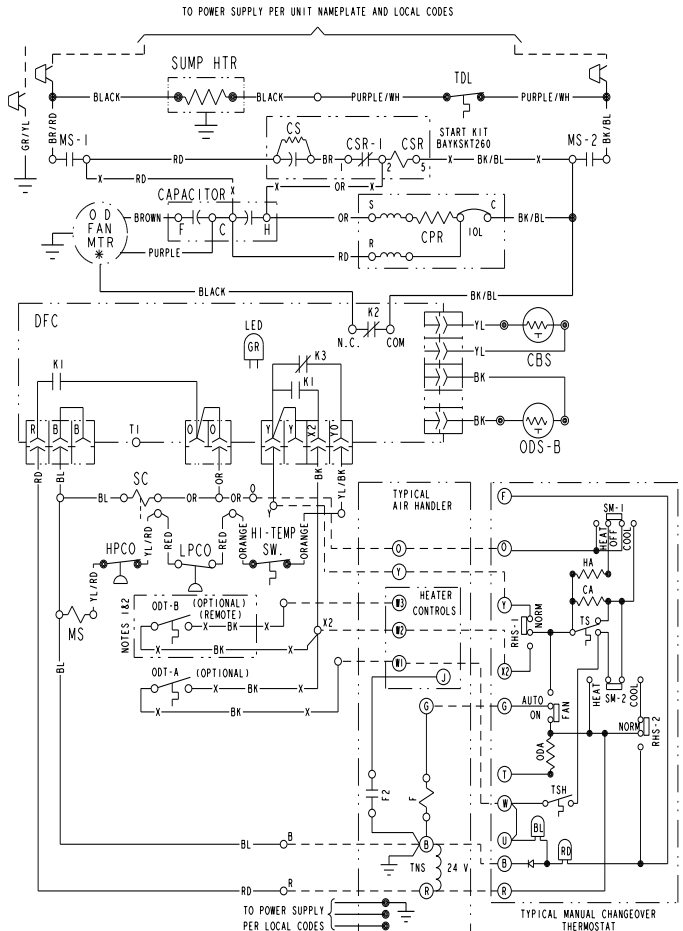

NOTES:

1. IF ODT-B IS NOT USED, ADD JUMPER BETWEEN W2 & W3 AT AIR HANDLER.
IF USED, ODT-B MUST BE MOUNTED REMOTE OF CONTROL BOX IN AN APPROVED WEATHER PROOF ENCLOSURE.
2. IF ODT-A IS NOT USED, ADD JUMPER BETWEEN W1 & W2 AT AIR HANDLER.
3. LOW VOLTAGE (24 V.) FIELD WIRING MUST BE 18 AWG MIN.

<p>⚠ WARNING HAZARDOUS VOLTAGE! DISCONNECT ALL ELECTRIC POWER INCLUDING REMOTE DISCONNECTS BEFORE SERVICING. FAILURE TO DISCONNECT POWER BEFORE SERVICING CAN CAUSE SEVERE PERSONAL INJURY OR DEATH!</p>	<p>⚠ CAUTION USE COPPER CONDUCTORS ONLY! UNIT TERMINALS ARE NOT DESIGNED TO ACCEPT OTHER TYPES OF CONDUCTORS. FAILURE TO DO SO MAY CAUSE DAMAGE TO THE EQUIPMENT!</p>
---	--

FOR CANADIAN INSTALLATIONS
POUR INSTALLATIONS CANADIENNES

CAUTION: NOT SUITABLE FOR USE ON SYSTEMS EXCEEDING 150V-TO-GROUND.
ATTENTION: NE CONVIENT PAS AUX INSTALLATIONS DE PLUS DE 150 V A LA TERRE.

Printed from D155592REV00

Typical Wiring

SCHEMATIC DIAGRAMS

4A6H3060A

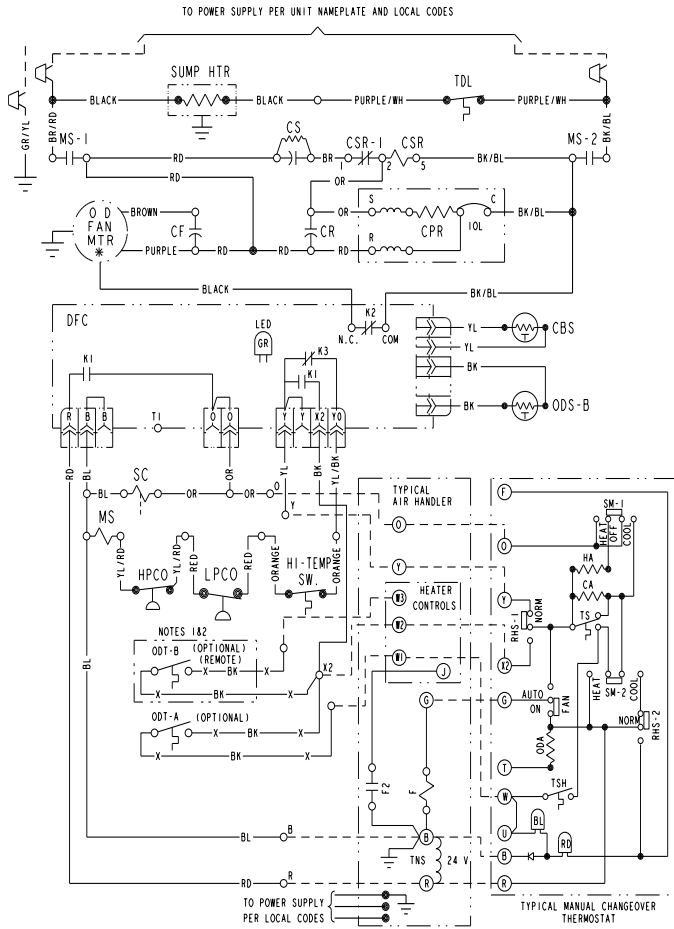

NOTES:

1. IF ODT-B IS NOT USED, ADD JUMPER BETWEEN W2 & W3 AT AIR HANDLER. IF USED, ODT-B MUST BE MOUNTED REMOTE OF CONTROL BOX IN AN APPROVED WEATHER PROOF ENCLOSURE.
2. IF ODT-A IS NOT USED, ADD JUMPER BETWEEN W1 & W2 AT AIR HANDLER.
3. LOW VOLTAGE (24 V.) FIELD WIRING MUST BE 18 AWG MIN.

<p>⚠ WARNING HAZARDOUS VOLTAGE! DISCONNECT ALL ELECTRIC POWER INCLUDING REMOTE DISCONNECTS BEFORE SERVICING. FAILURE TO DISCONNECT POWER BEFORE SERVICING CAN CAUSE SEVERE PERSONAL INJURY OR DEATH!</p>	<p>⚠ CAUTION USE COPPER CONDUCTORS ONLY! UNIT TERMINALS ARE NOT DESIGNED TO ACCEPT OTHER TYPES OF CONDUCTORS. FAILURE TO DO SO MAY CAUSE DAMAGE TO THE EQUIPMENT!</p>
---	--

FOR CANADIAN INSTALLATIONS
POUR INSTALLATIONS CANADIENNES
CAUTION: NOT SUITABLE FOR USE ON SYSTEMS EXCEEDING 150V-TO-GROUND.
ATTENTION: NE CONVIENT PAS AUX INSTALLATIONS DE PLUS DE 150 V A LA TERRE.

Printed from D155593REV00

LEGEND

COLOR OF WIRE			
BK/BL	BLACK WIRE WITH BLUE MARKER		
COLOR OF MARKER			
BK	BLACK	OR	ORANGE
BL	BLUE	RD	RED
BR	BROWN	WH	WHITE
		YL	YELLOW
		GR	GREEN
		PR	PURPLE

SYMBOLS

	24 V. LINE V.	} FACTORY WIRING
	24 V. LINE V.	
		} FIELD WIRING
		} FIELD INSTALLED FACTORY WIRING
	GROUND	
	JUNCTION	
	WIRE NUT OR CONNECTOR	
	COIL	
	CAPACITOR	
	RELAY CONTACT (N.O.)	
	RELAY CONTACT (N.C.)	
	THERMISTOR	
	INTERNAL OVERLOAD PROTECTOR	
	PRESSURE ACTUATED SWITCH	
	TEMP. ACTUATED SWITCH	
	POL. PLUG FEMALE HOUSING (MALE TERM.)	
	POL. PLUG MALE HOUSING (FEMALE TERM.)	
	RESISTOR OR HEATING ELEMENT	
	MOTOR WINDING	
	TERMINAL	

CA	COOLING ANTICIPATOR	LPCO	LOW PRESSURE CUTOUT SW.
CBS	COIL BOTTOM SENSOR	MS	COMPRESSOR MOTOR CONTACTOR
CF	FAN CAPACITOR	ODA	OUTDOOR ANTICIPATOR
CN	WIRE CONNECTOR	OFT	OUTDOOR FAN THERMOSTAT
CPR	COMPRESSOR	ODS	OUTDOOR TEMPERATURE SENSOR
CR	RUN CAPACITOR	ODT	OUTDOOR THERMOSTAT
CS	STARTING CAPACITOR	RHS	RESISTANCE HEAT SWITCH
CSR	CAPACITOR SWITCHING RELAY	SC	SWITCHOVER VALVE SOLENOID
DFC	DEFROST CONTROL	SM	SYSTEM "ON-OFF" SWITCH
F	INDOOR FAN RELAY	TDL	DISCHARGE LINE THERMOSTAT
HA	HEATING ANTICIPATOR	TNS	TRANSFORMER
HPCO	HIGH PRESSURE CUTOUT SW.	TS	HEATING-COOLING THERMOSTAT
IOL	INTERNAL OVERLOAD PROTECTOR	TSH	HEATING THERMOSTAT

PRODUCT DATA

American Standard Heating & Air Conditioning, Tyler, TX 75711-9010

Dimensional Data

4A6H3 OUTLINE DRAWING

NOTE: ALL DIMENSIONS ARE IN MM (INCHES).

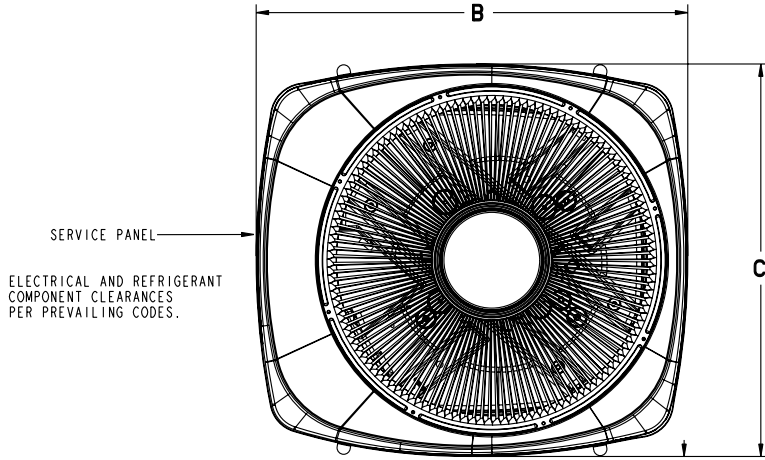

SERVICE PANEL
ELECTRICAL AND REFRIGERANT COMPONENT CLEARANCES PER PREVAILING CODES.

TOP DISCHARGE AREA SHOULD BE UNRESTRICTED FOR AT LEAST 1524 (5 FEET) ABOVE UNIT. UNIT SHOULD BE PLACED SO ROOF RUN-OFF WATER DOES NOT POUR DIRECTLY ON UNIT, AND SHOULD BE AT LEAST 305 (12") FROM WALL AND ALL SURROUNDING SHRUBBERY ON TWO SIDES. OTHER TWO SIDES UNRESTRICTED.

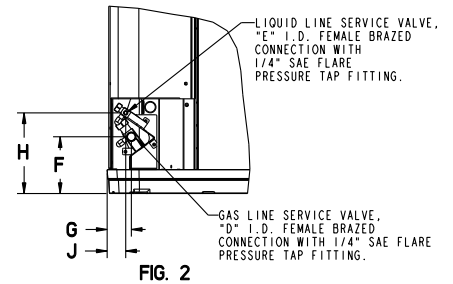
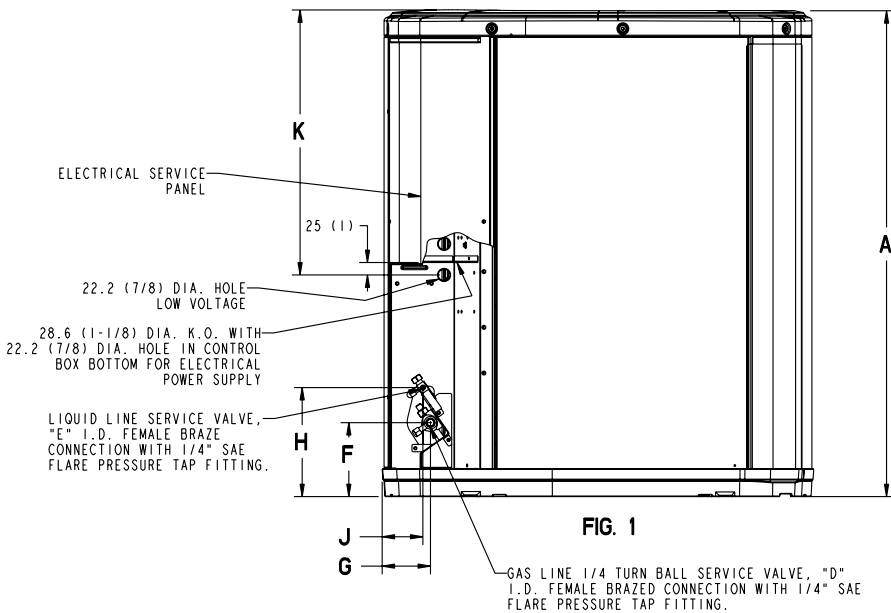

MODELS	BASE	FIG.	A	B	C	D	E	F	G	H	J	K
4A6H3018A	3	2	730 (28-3/4)	829 (32-5/8)	756 (29-3/4)	1/2	1/4	127 (5)	76 (3)	197 (7-3/4)	57 (2-1/4)	508 (20)
4A6H3024A	3	2	730 (28-3/4)	829 (32-5/8)	756 (29-3/4)	5/8	5/16	127 (5)	76 (3)	197 (7-3/4)	57 (2-1/4)	508 (20)
4A6H3030A	3	2	933 (36-3/4)	829 (32-5/8)	756 (29-3/4)	3/4	5/16	143 (5-5/8)	92 (3-5/8)	210 (8-1/4)	79 (3-1/8)	508 (20)
4A6H3036A	4	1	943 (37-1/8)	946 (37-1/4)	870 (34-1/4)	3/4	3/8	152 (6)	98 (3-7/8)	219 (8-5/8)	86 (3-3/8)	508 (20)
4A6H3042A	4	1	943 (37-1/8)	946 (37-1/4)	870 (34-1/4)	3/4	3/8	152 (6)	98 (3-7/8)	219 (8-5/8)	86 (3-3/8)	508 (20)
4A6H3048A	4	1	1045 (41-1/8)	946 (37-1/4)	870 (34-1/4)	7/8	3/8	152 (6)	98 (3-7/8)	219 (8-5/8)	86 (3-3/8)	508 (20)
4A6H3060A	4	1	1045 (41-1/8)	946 (37-1/4)	870 (34-1/4)	7/8	3/8	152 (6)	98 (3-7/8)	219 (8-5/8)	86 (3-3/8)	508 (20)

From Dwg. D153074 Rev. 13

Mechanical Specifications

General

These models shall be fully charged from the factory for matched indoor section and up to 15 feet of piping. This unit must be designed to operate at outdoor ambient temperatures as high as 115°F. Cooling capacities shall be matched with a wide selection of air handlers and furnace coils that are ARI certified. The unit shall be UL listed. Exterior must be designed for outdoor application.

Casing

Unit casing is constructed of heavy gauge, galvanized steel and painted with a weather-resistant powder paint finish on all louvered panels. Corrosion and weather-proof CMBP-G30 DuraBase™ base.

Refrigerant Controls

Refrigeration system controls include condenser fan and compressor contactor. High and low pressure controls are inherent to the compressor. Unit also has high pressure switch. Another standard feature is the liquid line drier.

Compressor

The Duration™ compressor features internal over temperature and pressure protector, dipped hermetic motor and sump heater. Other features include: roto lock suction and discharge refrigerant connections, centrifugal oil pump, and low vibration and noise. The Duration™ compressor features a 10-year limited warranty.

Condenser Coil

The Spine Fin™ coil shall be continuously wrapped, corrosion resistant all aluminum with minimum brazed joints. This coil is seamless aluminum glued to a continuous aluminum fin. Coils are lab tested to withstand 2,000 pounds of pressure per square inch.

Low Ambient Cooling

As shipped, this unit has a cooling capability to 55°F. The addition of an evaporator defrost control permits operation to 40°F. The addition of an evaporator defrost control with TXV permits low ambient cooling to 30°F.

Accessories

Thermostats —

Heat/cooling (manual and automatic changeover). Sub-base to match thermostat and locking thermostat cover.

Evaporator Defrost Control —

See Low Ambient Cooling.

Outdoor Thermostat —

Supplemental heat outdoor ambient lockout from 46 to -10°F.

Since the manufacturer has a policy of continuous product and product data improvement, it reserves the right to change design and specifications without notice.

Technical Literature - Printed in U.S.A.

American Standard Heating & Air Conditioning

Troup Highway

Tyler, TX 75711-9010