

OIL FIRED CENTRAL FURNACE

THV1M087A936 - 948SA, TLF1M087A936 - 948SA

TLR1M087A936 - 948SA, TDF1M087A936 - 948SA

IMPORTANT — This document contains a wiring diagram and service information. This is customer property and is to remain with this furnace. Please return to service information pack upon completion of work.

⚠ WARNING DISCONNECT POWER BEFORE SERVICING

Oil Fired Furnace Specifications												
Model	THV1M087A936 & 948SA				TLF1M087A936 & 948SA TLR1M087A936 & 948SA				TDF1M087A936 & 948SA			
Type	Upflow - Highboy				Upflow - Lowboy				Downflow - Horizontal			
Heat input Rate (BTUH):	140,000	119,000	105,000	84,000	140,000	119,000	105,000	84,000	140,000	119,000	105,000	84,000
Nominal Thermal Efficiency (%):	83.6				84.2				83.8			
Heating Capacity (BTUH):	114,000	98,000	87,000	70,000	114,000	98,000	87,000	70,000	114,000	98,000	87,000	70,000
Nominal Temperature Rise (deg. F):	85				85				85			
Minimum AFUE (I.C.S.) Rating (%):	THV1M087A936SA - 82.9% THV1M087A948SA - 82.6%				TLF1M087A936SA - 82.9% TLF1M087A948SA - 82.7% TLR1M087A936SA - 85.0% ** TLR1M087A948SA - 82.4%				TDF1M087A936SA - 84.8% TDF1M087A948SA - 82.6%			
Burner Specifications:	R.W. Beckett Pressure Atomizing Type, Model AF				R.W. Beckett Pressure Atomizing Type, Model AF				R.W. Beckett Pressure Atomizing Type, Model AF			
Air Tube Length (in.):	5.875, Effective				5.875, Effective				5.875, Effective			
Burner Head Type:	Fixed, Flame Retention				Fixed, Flame Retention				Fixed, Flame Retention			
Fuel Type:	# 2 Distillate (Domestic Heating Oil)				# 2 Distillate (Domestic Heating Oil)				# 2 Distillate (Domestic Heating Oil)			
Nozzle Rating For Beckett AF (GPH):	1.00	0.85	0.75	0.60	1.00	0.85	0.75	0.60	1.00	0.85	0.75	0.60
Spray Angle (deg.):	80				80				80			
Spray Pattern:	Hollow				Hollow				Hollow			
Oil Pump Pressure (PSIG):	130				130				130			
Ignition Control Type:	Interrupted, Direct Spark				Interrupted, Direct Spark				Interrupted, Direct Spark			
Pre / Post Purge Feature(s):	Yes / no				Yes / no				Yes / no			
Automatic Oil Solenoid Valve:	Yes				Yes				Yes			
Blower Drive:	Direct				Direct				Direct			
	THV1M087A936SA	THV1M087A948SA	TLF1M087A936SA	TLF1M087A948SA	TLR1M087A936SA	TLR1M087A948SA	TDF1M087A936SA	TDF1M087A948SA				
Diameter x Width (in.):	10 x 9	11 x 11	10 x 9	10 x 9	10 x 9	10 x 9	10 x 9	11 x 9				
No. Used:	1	1	1	1	1	1	1	1				
Speeds (no.):	4	4	4	4	4	4	4	4				
CFM vs in. w.g.:	See Fan Performance Table				See Fan Performance Table				See Fan Performance Table			
Motor HP:	1/2	3/4	1/2	3/4	1/2	3/4	1/2	3/4				
R.P.M.:	1075	1130	1075	1130	1075	1130	1075	1130				
Volts / Ph. / Hz.:	120 / 60 / 1				120 / 60 / 1				120 / 60 / 1			
Filter Furnished?:	Yes				Yes				No			
Type Recommended:	Throwaway				Throwaway				Throwaway			
No. - Size x Thick:	1 - 16 x 25 x 1				2 - 10 x 20 x 1				Not Supplied			
Vent - Size (in.):	6				6				6			
Gross Heat Exchanger Area (sq. ft.):	27.8				27.8 (Front Flue) / 30.0 (Rear Flue)				27.8			
Supply / Return Size (in. x in.):	See Outline Drawing				See Outline Drawing				See Outline Drawing			
Combustion Chamber Type:	Preformed, Refractory (Ceramic Fiber Matrix Material)				Preformed, Refractory (Ceramic Fiber Matrix Material)				Preformed, Refractory (Ceramic Fiber Matrix Material)			
Total Current (amps.):	12.1	19.8	12.1	19.8	12.1	19.8	12.1	19.8				
Max. Fuse Size (amps.):	15	30	15	30	15	30	15	30				
Dimensions uncrated (in.):	H X W X D 58 X 22.25 X 31				H X W X D 41.5 X 22.25 X 47				H X W X D 22.25 X 61.25 X 22.25			
Weight Shipping (lbs.) / Net (lbs.):	260 / 250				300 / 290				280 / 270			
** Energy Star												

NOTICE: Since the manufacturer has a policy of continuous product and product data improvement, it reserves the right to change design and specifications without notice.

Service Facts

Furnace Airflow (CFM) vs. External Static Pressure (in. WC)								
Model	Speed Tap	0.1	0.2	0.3	0.4	0.5	0.6	0.7
Highboy THV1M087A936SA	High	1508	1468	1407	1345	1278	1202	1120
	Med-High	1420	1361	1310	1242	1176	1096	1019
	Med-Low	1308	1263	1220	1174	1103	1031	953
	Low	1189	1150	1113	1072	1009	936	870
Highboy THV1M087A948SA	High	1974	1913	1854	1766	1695	1621	1547
	Med-High	1694	1643	1589	1534	1477	1406	1339
	Med-Low	1413	1384	1348	1315	1280	1235	1184
	Low	1166	1144	1127	1105	1076	1027	983
Lowboy Front Flue TLF1M087A936SA	High	1688	1648	1595	1522	1447	1373	1309
	Med-High	1372	1331	1290	1246	1200	1146	1079
	Med-Low	1173	1156	1134	1108	1082	1043	989
	Low	999	993	975	956	931	888	807
Lowboy Front Flue TLF1M087A948SA	High	1920	1822	1730	1649	1564	1483	1397
	Med-High	1620	1572	1511	1443	1376	1311	1224
	Med-Low	1358	1339	1309	1264	1216	1167	1098
	Low	1103	1106	1080	1056	1023	981	858
Lowboy Rear Flue TLR1M087A936SA	High	1669	1599	1541	1475	1409	1329	1231
	Med-High	1410	1345	1299	1246	1184	1127	1171
	Med-Low	1196	1184	1149	1111	1066	1023	938
	Low	1007	1004	985	963	915	845	749
Lowboy Rear Flue TLR1M087A948SA	High	1844	1771	1694	1612	1538	1451	1355
	Med-High	1622	1545	1484	1419	1356	1274	1172
	Med-Low	1366	1330	1303	1247	1187	1124	1046
	Low	1110	1107	1091	1068	1031	973	887
Downflow/Horizontal TDF1M087A936SA	High	1616	1550	1482	1406	1347	1231	1144
	Med-High	1447	1397	1343	1284	1209	1127	1043
	Med-Low	1320	1274	1228	1176	1111	1043	950
	Low	1166	1139	1107	1064	1017	955	871
Downflow/Horizontal TDF1M087A948SA	High	1901	1837	1790	1714	1648	1584	1496
	Med-High	1615	1572	1521	1468	1412	1355	1308
	Med-Low	1355	1342	1311	1273	1230	1183	1133
	Low	1116	1105	1084	1058	1038	1001	955

Service Facts

CFM vs. Temperature Rise														
Model	Heating Capacity													
		800	900	1000	1100	1200	1300	1400	1500	1600	1700	1800	1900	2000
Highboy THV1M087A936SA	70,000		72	65	59	54	50	46	43					
	87,000		90	81	73	67	62	58	54					
	98,000		101	91	82	76	70	65	60					
	114,000		117	106	96	88	81	75	70					
Highboy THV1M087A948SA	70,000			65	59	54	50	46	43	41	38	36	34	32
	87,000			81	73	67	62	58	54	50	47	45	42	40
	98,000			91	82	76	70	65	60	57	53	50	48	45
	114,000			106	96	88	81	75	70	66	62	59	56	53
Lowboy Front Flue TLF1M087A936SA	70,000		72	65	59	54	50	46	43	41				
	87,000		90	81	73	67	62	58	54	50				
	98,000		101	91	82	76	70	65	60	57				
	114,000		117	106	96	88	81	75	70	66				
Lowboy Front Flue TLF1M087A948SA	70,000		72	65	59	54	50	46	43	41	38	36	34	
	87,000		90	81	73	67	62	58	54	50	47	45	42	
	98,000		101	91	82	76	70	65	60	57	53	50	48	
	114,000		117	106	96	88	81	75	70	66	62	59	56	
Lowboy Rear Flue TLR1M087A936SA	70,000	81	72	65	59	54	50	46	43	41	38			
	87,000	101	90	81	73	67	62	58	54	50	47			
	98,000	113	101	91	82	76	70	65	60	57	53			
	114,000	Not allowed	117	106	96	88	81	75	70	66	62			
Lowboy Rear Flue TLR1M087A948SA	70,000		72	65	59	54	50	46	43	41	38	36		
	87,000		90	81	73	67	62	58	54	50	47	45		
	98,000		101	91	82	76	70	65	60	57	53	50		
	114,000		117	106	96	88	81	75	70	66	62	59		
Downflow/Horizontal TDF1M087A936SA	70,000		72	65	59	54	50	46	43	41				
	87,000		90	81	73	67	62	58	54	50				
	98,000		101	91	82	76	70	65	60	57				
	114,000		117	106	96	88	81	75	70	66				
Downflow/Horizontal TDF1M087A948SA	70,000			65	59	54	50	46	43	41	38	36	34	
	87,000			81	73	67	62	58	54	50	47	45	42	
	98,000			91	82	76	70	65	60	57	53	50	48	
	114,000			106	96	88	81	75	70	66	62	59	56	

The unshaded area is the recommended operating range for HEATING comfort

Service Facts

SERVICE

WARNING

EXPLOSION HAZARD

DO NOT use this furnace if any component has been underwater. Immediately call a qualified heating contractor to inspect the furnace and replace any part of the soft ceramic fiber refractory chamber or furnace control system that has been exposed to water.

Failure to follow this warning may cause property damage, personal injury or death.

TROUBLESHOOTING

WARNING

SHOCK HAZARD

When testing electrical equipment, always follow standard electrical safety procedures.

Before beginning these troubleshooting procedures, always review these basic points:

- 1) Check for 120 VAC power to the furnace. If there is no voltage, check the disconnecting switch for circuit breaker trip or blown fuses.
- 2) Make sure the room Comfort Control is set on the heating mode and is “calling for heat”.
- 3) Check for sufficient oil supply and that all oil shutoff valves are open.
- 4) To successfully service this oil furnace, the following recently (within the last year) calibrated instruments must be available.
 - Smoke spot test kit with Bacharach-type oil burner smoke scale
 - Carbon dioxide (CO₂) and carbon monoxide (CO) test kit or analyzer
 - Flue gas temperature measuring instrument
 - Draft gauge, capable of measuring 0.01 to 0.25 in. W.G. draft (Draft is the pressure differential between the static pressure measured in the vent pipe, or just above the combustion chamber, and the indoor atmospheric pressure. Under normal operating conditions, it will have a **negative** value, i.e. the pressure in the combustion chamber and the vent system are less than room air pressure.)
 - Multimeter (analog or digital type)
 - Oil pressure gauge, capable of measuring at least 0 to 200 PSIG
 - Burner electrode and nozzle setting gauge
- 5) Be familiar with the correct operation of these instruments as well as how to adjust the oil burner settings (refer to burner manufacturer’s literature).

WARNING

EXPLOSION HAZARD

Repeated operation of the oil primary safety control reset button can cause a build-up of unburned oil in the combustion chamber. An accumulation of oil in the combustion chamber is a hazardous situation and may cause a fire or explosion.

A. Symptom: Furnace does not operate.

Items to check:

- 1) Make sure the disconnecting switch is “ON” and the circuit breaker has not tripped, or fuses have not blown.
- 2) Confirm there is 120 VAC at the fan center junction box.
- 3) Confirm the room Comfort Control is wired correctly, set on the “HEAT” mode, and “calling for heat”.
- 4) On the Honeywell oil primary control, lockout has occurred if the indicator light (an LED) is rapidly flashing; depress the oil primary reset button.

If the burner does not operate properly after depressing the reset button three (3) times, turn off the electrical power to the furnace and close the manual oil shutoff valve. Reference the Honeywell literature insert shipped with the furnace for detailed diagnostic information.

B. Symptom: Burner short cycles or “locks out” on oil primary safety control.

Items to check:

- 1) Fuel oil tank nearly empty or oil flow restriction. Refill oil tank, replace oil filter, open all shutoff valve(s), and purge oil line(s) of air.
- 2) If the oil primary control has not “locked out” (e.g., on the Honeywell primary control, the indicator light is not flashing), measure the electrical current to the room Comfort Control. Set the heat anticipator on the room Comfort Control to the current value measured. Also, check the wiring between the Comfort Control and primary control to be sure it is correct and no loose connections exist.
- 3) Inspect the burner flame sensor, “cad cell”, to be sure the lens is clean and the cell is correctly aimed at the flame.
- 4) Inspect the burner oil nozzle for blockages and signs of deterioration. Replace the nozzle, if required. Also, measure and reset the electrode gap and alignment. If badly worn or deformed, replace the electrodes. (Refer to the burner manufacturer’s instructions.)
- 5) Confirm there is a strong spark across electrodes. Generally, viewing a spark jump across the electrodes is sufficient indication the ignition transformer is operating correctly. **Testing an electronic ignition transformer with a transformer tester is generally not recommended.**
- 6) Inspect the heat exchanger through the cleanout ports for signs of excessive soot, scale buildup, or blockage. If a heavy deposits are present, clean the heat exchanger.

C. Symptom: Burner short cycles on high limit thermo stat, but does not “lock out” on oil primary safety control.

Items to check:

- 1) Open dampers or registers in the air distribution system. Clear any duct system restrictions.
- 2) Inspect and clean all air filters in the air distribution system.
- 3) Inspect blower for interference with rotation or locked rotor condition. Also, confirm the blower wheel is secured to the fan motor shaft.
- 4) The fan motor or run capacitor may be damaged. Test and replace the motor or capacitor, as required.
- 5) Increase fan speed.

D. Symptom: Unable to achieve clean combustion by making burner air adjustments.

Items to check:

- 1) **Measure the burner air tube insertion depth and alignment. The end of the tube should not protrude inside the combustion chamber. The end of the tube should be approximately ¼ inch away from the inner wall surface of the combustion chamber.**
- 2) Inspect the oil nozzle for excessive wear, blockage, or deterioration. Measure and, if necessary, reset the nozzle depth or turbulator location with respect to end of the burner head. Replace the nozzle, if necessary (refer to the oil burner manufacturer's instructions).
- 3) Measure the oil pump pressure. If required, adjust the pressure to burner nameplate value. (This is the typical minimum pressure required to obtain the full input rate from the furnace).
- 4) **Verify the burner is configured as specified in Table 1 and adjusted according to the Initial Burner Operation section of this manual (page 8) and the burner manufacturer's instructions.**
- 5) Measure the overfire draft. If required, adjust the barometric damper to increase the stack draft to obtain an overfire draft of 0.02 in. W.G. with the burner operating. (This is the typical minimum draft required to obtain the specified flue gas combustion analysis values given in Table 1.) If the specified overfire draft cannot be obtained with a stack draft of 0.02 in. W.G., the heat exchanger may be partially blocked and could require cleaning.
- 6) Measure the draft at the point where the vent connector attaches to the heat exchanger flue pipe. With the burner operating, the stack draft should not exceed 0.05 in. W.G. If the stack draft has been adjusted above this value to give the proper overfire draft, the heat exchanger will require cleaning.

If there is little or no stack draft, the chimney flue way may require cleaning, the chimney is too restrictive, or a downdraft condition exists.

E. Symptom: Furnace blower will not start.

Items to check:

- 1) Confirm there is 120 VAC at the blower motor terminal block.
- 2) If there is **not** 120 VAC at the blower terminal block, measure the voltage at the fan center relay. If the fan can be activated by itself from the room Comfort Control subbase, confirm it will operate.

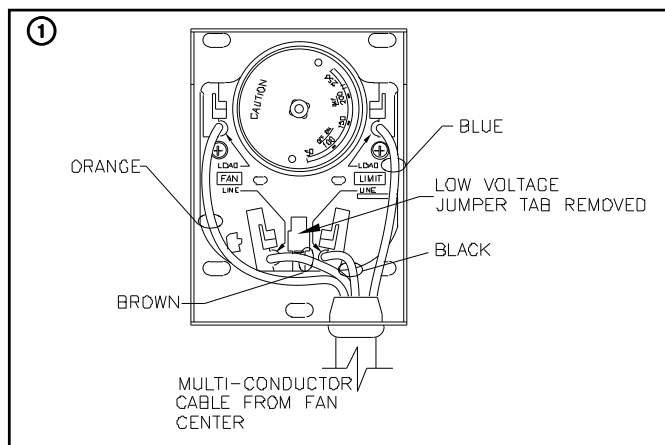

If so, the fan center relay contacts may be burnt, or damaged, or the fan limit control may be defective. Test these components and replace the defective component, as required.

- 3) If there is 120 VAC at the blower terminal block, either the run capacitor or blower motor may be damaged. Test and replace the capacitor or motor, as required.

F. Symptom: Blower cycles on and off after the burner has shutdown.

Item to check:

- 1) Increase the fan limit control differential. Typically, the fan "off" setting should be 30 degrees F. below the fan "on" setting. Adjust the setting as required.

⚠ WARNING

FIRE HAZARD

If the fan and high limit control is faulty, it should be replaced. However, it must only be replaced by the same make and model as the original. All the original temperature settings should be duplicated on the replacement model as well. REMOVE THE LOW VOLTAGE JUMPER IN THE CONTROL, IF EQUIPPED. See Figure 1. Refer to the electrical diagram for proper electrical connections. (page 10 & 11)

FLAME SENSOR ("CAD CELL") CHECKOUT PROCEDURE

On the Honeywell oil primary control, to check the electrical resistance of the flame sensor (referred to as a cadmium sulfide photocell, or "cad cell"), depress the reset button on the oil primary safety control while the burner is firing. The oil primary control will report the measured resistance range of the cad cell by flashing the LED (light emitting diode) one (1) to four (4) times. Refer to the oil burner manufacturer's instructions for further details.

For all primary controls, an alternate procedure to check the flame sensor operation is as follows:

- 1) Remove the flame sensor lead wires from the terminals (labeled "CAD CELL" on the underside of the Honeywell control) of the oil primary safety control module. Start the burner. Shortly after combustion is established, place a temporary jumper wire across the cad cell terminals, or leads, of the control. Connect an ohmmeter across the flame sensor lead wires. The measured resistance should be less than,
 - 1600 Ohms for the Honeywell cad cell.
- 2) Stop the burner and remove the jumper wire.
- 3) With the burner off, measure the resistance of the flame sensor with the ohmmeter. The resistance of the sensor without "seeing" a light source (so-called "dark" cell resistance) should be greater than,
 - 20,000 Ohms for the Honeywell cad cell.
- 4) If the sensor resistances are outside the acceptable ranges given above, confirm the lens of the cell is clean and the cell is located correctly in the burner housing. If the cell is clean and correctly located, replace the flame sensor.

NOTICE: All resistances are approximate values only and will vary depending upon the intensity of the light source (flame or sunlight) and the condition or age of the cad cell.

Service Facts

MAINTENANCE

Air Filter(s)

⚠ CAUTION

BURN HAZARD - ROTATING FAN BLADES

To avoid injury from moving parts, hot surfaces, or electrical shock, shut off the power to the furnace and allow the furnace to cool BEFORE removing any furnace access doors to service air filters.

Highboy and lowboy furnace models are factory-supplied with a permanent-type, air filter. Downflow/Horizontal models are not shipped with a filter. However, external filters are required. At least twice a year, remove the air filter(s) for cleaning. To clean a washable filter, soak it in water with a mild detergent and then rinsing it with clean water. Allow the filter to air dry before reinstalling it in the furnace filter rack. If the furnace, or duct system, is equipped with disposable-type (paper element), air filters, inspect them every month for an excessive accumulation of dust and dirt. Replace disposable air filters at least twice a year. Make certain the replacement filter is the same size as the one being replaced. The filter size is marked on the outer edge of the air filter. Install the filter with the arrow marked on the filter pointing toward the furnace.

Oil Burner

⚠ WARNING

ANNUAL SERVICE REQUIRED

A qualified heating contractor **MUST** service the oil burner in this furnace at least once a year.

Generally, service to the burner will involve a thorough inspection and cleaning of the burner, replacement of the oil nozzle and oil filter, and readjustment of the burner to achieve proper ignition and clean combustion.

Blower and Motor

NOTICE: The fan motor has sealed bearings that do NOT require lubrication.

The blower and fan motor will **not** normally require any service. This furnace is equipped with a directly-driven blower. Therefore, it will **not** require any retensioning or replacement of a drive belt.

Heat Exchanger

⚠ WARNING

BURN HAZARD

DO NOT attempt to clean the heat exchanger unless electrical power and fuel flow to the furnace are turned off and the furnace is at room temperature.

⚠ CAUTION

FRAGILE

The combustion chamber refractory material is fragile and can be easily damaged. If the inner radiator of the heat exchanger is cleaned, avoid scraping or hitting the walls of the combustion chamber.

⚠ CAUTION

FRAGILE

Do NOT brush or scrape the surface of the combustion chamber. It can be easily damaged.

⚠ CAUTION

ANNUAL SERVICE REQUIRED

A qualified heating contractor **MUST** inspect the heat exchanger in this furnace at least once a year. If heavy deposits are found, immediate cleaning is required.

All heat exchanger surfaces should be as clean as possible for the most efficient operation of the furnace. The heat exchanger may require cleaning after every heating season, as combustion of fuel oil tends to produce soot, particulate matter, and scale, due to corrosion. These materials coat the inner walls of the heat exchanger. This coating reduces the heat transfer effectiveness of the heat exchanger and can hinder the flow of flue gases from the furnace.

NOTICE: Accumulation of heavy soot deposits over one heating season may indicate the oil burner is out of adjustment.

The heat exchanger may be inspected and cleaned through two (2) access, or cleanout, ports located in the burner compartment, on highboy and lowboy models, or protruding through the front casing panel, on the horizontal/downflow model. Each cleanout port consists of a 2-inch O.D. tube closed by a pressed-in cap, refer to Figure 2.

Using a screwdriver, or a large pair of adjustable jaw pliers, remove each cleanout port cap. With the aid of a portable light source, peer into the heat exchanger. As much as possible, loosen all material and deposits clinging to the heat exchanger walls using wire brushes, or any suitable tool. Collect and remove this material by hand or with the assistance of a vacuum cleaner and a nozzle-type attachment.

The heat exchanger may also be cleaned through the flue pipe connection. With the furnace turned off and at room temperature, carefully remove the vent connector and the heat exchanger flue pipe, if equipped, to inspect and clean the heat exchanger.

The inner radiator of the heat exchanger may be cleaned from the inside of the combustion chamber. This involves removal of the burner and the burner mounting plate from the heat exchanger.

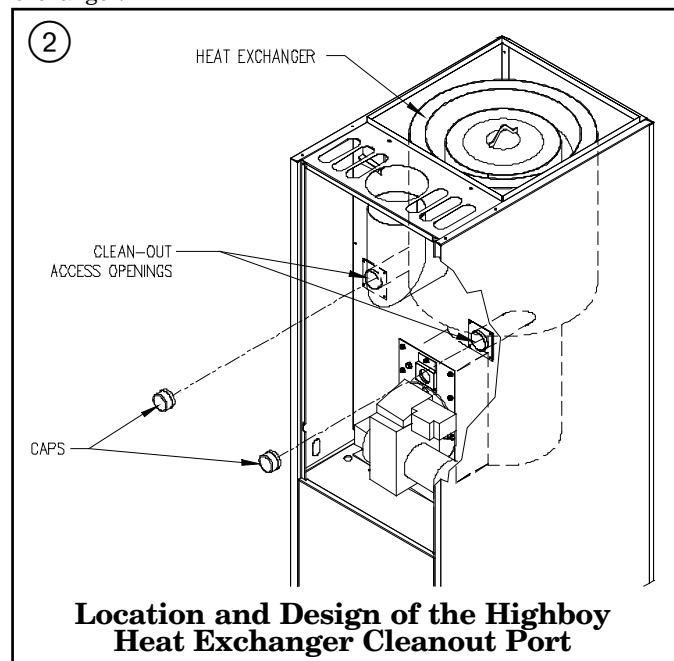

Using a portable light source with a mirror inserted through and into the heat exchanger, check for an accumulation of soot, scale, and particulate matter on the walls and in the base of the drum, or on the floor of the combustion chamber. If a significant accumulation is present, it should be removed. Use a flexible wire brush to loosen the deposits on the heat exchanger walls. Remove any loose foreign material using a vacuum cleaner. Replace all gaskets, if removed, with new (unused) gaskets. Reassemble the burner mounting plate, burner flange, and new gaskets in the reverse order they were removed. A rubber mallet, or equivalent tool, may be useful for reinstalling the caps in the cleanout tubes.

WARNING

RE-INSTALL ALL PARTS

Should the unit be disassembled, all components, panels, block offs, collars, gaskets and fasteners must be reassembled as originally factory produced.

Failure to do so may result in property damage, injury, or loss of life!

Flue and Chimney

At least once a year, thoroughly inspect the heat exchanger flue pipe, the vent connector, the chimney, or vent, and the barometric damper for signs of sagging, loose connections, excessive corrosion, and deterioration. Clean, repair, or replace any components for continued safe and proper operation of the furnace.

INITIAL OPERATION OF THE FURNACE

INITIAL BURNER OPERATION

WARNING

EXPLOSION HAZARD

To avoid possible explosion, DO NOT attempt to light the burner if:

- Oil has accumulated in the base of the combustion chamber.
- The furnace is full of fuel vapors.
- The combustion chamber is very hot.

CAUTION

SERVICE INSTRUCTIONS

The oil burner must be installed and adjusted using recently (within the last year) calibrated combustion instruments by a qualified heating dealer prior to placing the furnace in operation. Refer to this manual and the oil burner instruction manual for details.

CAUTION

MINIMIZE OIL ODOR

To minimize initial fuel oil and combustion odors, ventilate the building well while operating the furnace for the first time.

Do NOT run the oil pump dry (without oil) for more than two (2) minutes. Damage to the oil pump may result.

To initially operate the furnace:

- 1) Turn the electrical disconnecting switch to the "OFF" position.
- 2) Set the room Comfort Control above room temperature.
- 3) Be sure the oil tank is full of clean # 2 fuel oil.
- 4) Open all shutoff valves in the oil line.

- 5) Turn on the electrical disconnecting switch and prime the burner oil pump according to the pump manufacturer's instructions.
- 6) When ignition is established, make a temporary air adjustment for a clean, smoke-free flame. At this point, the final burner adjustment should be made using test instruments to measure oil pump pressure, smoke number, carbon dioxide (CO₂), carbon monoxide (CO), draft, and flue gas temperature.
 - Refer to item (4) under the Troubleshooting section of this manual for a list of required test instruments.

In order to achieve the best combustion efficiency, the following procedure is recommended.

- 7) Measure the oil pump pressure. If required, adjust it to deliver the appropriate pressure for the burner. The oil pump should be set to produce 130 PSIG, for the R.W. Beckett model AF burner.
- 8) Carbon Dioxide (CO₂) and Carbon Monoxide (CO) – In order to assure that proper and safe combustion is taking place, carbon dioxide and carbon monoxide measurements must be taken. A CO₂ reading within the limits of Table 1 with no measurable CO is desirable. The maximum acceptable CO reading is about 50 PPM. If the CO reading is too high, open the burner air shutter, or air band, slightly to permit more combustion air to the flame. Recheck the CO level and adjust as required.
- 9) Draft – Draft measurements should be taken through the overfire port and in the vent connector, not more than 12 inches away from the furnace outlet. A 5/16 in. hex washer head bolt plugs the overfire port in the burner mounting plate. Remove the bolt and insert a suitable draft measurement gage. After the chimney (or stack gas passageway) has warmed up to operating temperature, approximately 15 to 20 minutes of burner operation, adjust the barometric damper to obtain the correct overfire draft reading. The overfire draft should read 0.02 in. W.G. The draft measured at the flue (stack draft) should read no more than 0.05 in. W.G.

NOTICE: The overfire draft is the more important measurement and should be used to adjust the setting of the barometric draft control.

- 10) Flue Gas Temperature – The flue gas temperature will vary depending on heat input rate, air temperature rise across the heat exchanger, and air flowrate through the furnace. To prevent excessive water vapor condensation from the flue gases, the gross flue gas temperature should not fall below 330°F. In addition, if the gross flue gas temperature exceeds 650°F, the heating efficiency of the furnace will be reduced.

To reduce high flue temperatures, after properly adjusting the burner, check for blocked supply/return airflow. Remove any blockages, increase fan speed, or consider reducing the furnace heat input rate. Also, verify there is no air leakage into the combustion chamber from around the burner mounting flange or heat exchanger mounting plate. If flue gas temperatures are too low, consider increasing the heat input rate or reducing the amount of supply/return airflow.
- 11) Cycle the furnace several times to verify the burner lights off and shutdown smoothly without excessive noise or smoke production.

Service Facts

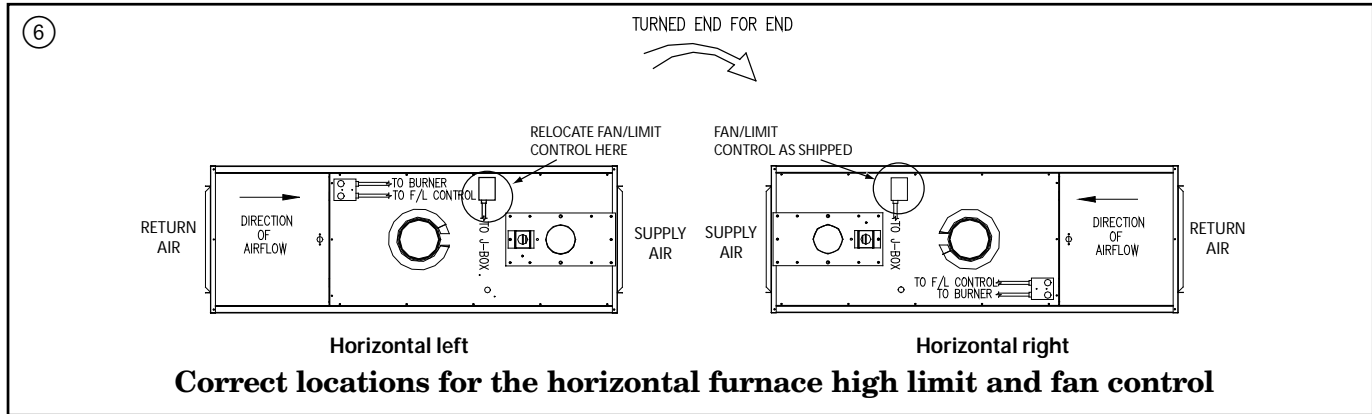

Furnace Model:	All
Burner Model:	R.W. Beckett, AF
Standard Nozzle:	Delavan, 0.75 GPH / 80 deg. angle / hollow cone
Oil Pump Pressure (PSIG):	130
Burner Head Type:	F3
Head / Turbulator Setting:	"Z" = 1.125 in.
Air Band Setting:	Fully-closed
Air Shutter / Damper Setting:	5
Overfire Draft (in. W.G.):	0.02
Smoke Spot, Maximum (Bacharach Scale):	# 1
Carbon Dioxide, CO ₂ , Maximum (%):	13
Carbon Dioxide, CO ₂ , Minimum (%):	12*
Carbon Monoxide, CO (PPM)	0
Oil Solenoid Valve Equipped:	YES
Delay valve on Time (sec):	15 sec.
Postpurge Time (sec):	None
Ignition Type:	Interrupted

Table 1: Oil Burner Application and Specifications

* When operating these furnaces at the lowest input rate (84,000 BTUH), the carbon dioxide (CO₂) value may not be able to be adjusted above 12%. This is normal and does not necessarily indicate a problem.

SUPPLY/RETURN AIRFLOW AND AIR TEMPERATURE

The supply/return airflow shall be set to obtain an air temperature rise, across the furnace, in the range of 70 to 100°F. See CFM vs Temperature Rise table, Page 3. Since the flow resistance of each duct system is slightly different, the airflow (fan speed) may have to be changed in the field to achieve a satisfactory temperature rise.

One way to measure the temperature rise across the furnace is to insert temperature measuring devices (e.g. thermometers) into the return air duct and into the supply air duct about 12 inches from the furnace. After the furnace has been firing continually for over 20 minutes, read the temperature difference between the two (2) thermometers. The temperature difference should not exceed 100°F, nor be less than 70°F. A temperature rise of 85°F is considered to be optimum for comfort. For better energy efficiency, a temperature rise closer to 70°F is recommended.

The blower (fan) speed fan is adjusted by changing the fan motor winding energized by the control system. The furnace is set on the lowest fan speed, "L", at the factory, refer to Table 2. To adjust the fan speed, follow this procedure:

- Turn off all electrical power to the furnace at the disconnecting switch.

- Remove the blower compartment access door.

- Move the orange wire from the low speed terminal block, marked "L", to the next higher fan speed (medium low), marked "ML" on the terminal block, refer to Figure 3. Other available higher fan speeds are medium high, marked "MH" and high, marked "H".

NOTICE: The red wire is normally positioned on the high fan speed, for cooling applications. However, the red wire may be moved to another terminal block position, as required.

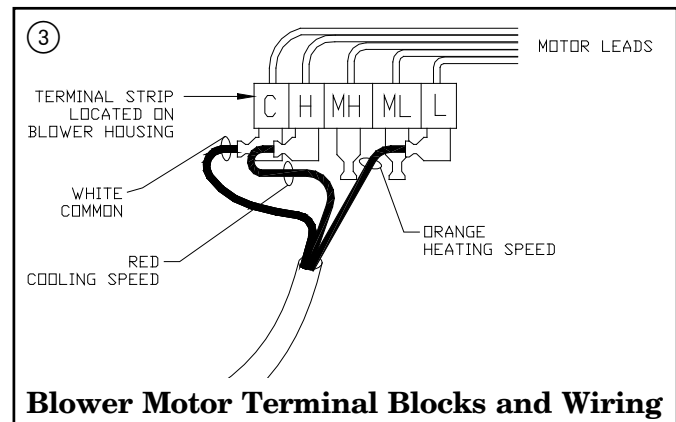

High Limit Thermostat Setting (deg. F.):	230 (highboy / lowboy models) 190 (horizontal / downflow model)
Fan "On" Setting (deg. F.):	130
Fan "Off" Setting (deg. F.):	100
Standard Fan Speed as shipped	Low, Orange Wire to "L" Terminal

Table 2: Standard Furnace Fan / Limit Control and Speed Settings

- d. Replace the blower compartment access door.
- e. Restore electrical power to the furnace at the disconnecting switch.

With the furnace operating, measure the air temperature rise across the furnace again. If the value does not fall in the range of 70 to 100°F, repeat the above procedure.

FURNACE LIMIT AND BLOWER CONTROLS

All furnaces are equipped with a combined thermostatic high temperature limit and blower (fan) control. The high temperature limit is set such that it does not permit a supply (discharge) air temperature above its setting. See Table 2.

The thermostatic fan control should be set so the greatest fuel utilization efficiency of the furnace is obtained. Generally, a blower "ON" setting of 130°F should give the best result. After the burner shuts down, the circulating air blower will continue to operate until the air temperature inside the furnace falls below the lower setting on the fan control.

This delay on blower shutdown extracts residual heat from the furnace heat exchanger that would ordinarily be lost to the outdoor atmosphere. If a longer, or shorter, cooldown period is desired, the fan control differential setting may be reset to lengthen, or shorten, the cycle as desired. Refer to Table 2 for the standard fan and high limit control settings. In addition to the combined fan and limit control, the horizontal / downflow furnace is equipped with an **auxiliary high limit temperature control** located in the blower compartment, refer to the electrical diagram on page 10. The purpose of this control is to prevent overheating of the blower motor and air filter(s), if airflow is severely reduced.

If the duct system becomes partially, or totally, blocked or the furnace air filter(s) become excessively dirty causing the blower to fail to circulate enough air, the thermostatic high temperature limit (or, if equipped, the auxiliary high temperature limit) may activate to prevent very high discharge air temperatures from occurring.

Should airflow be restricted, the furnace might cycle on and off too frequently or become inoperative. To correct this condition, verify that all supply and return dampers and registers in the air distribution system are open. If this fails to resolve the problem, turn off the electrical power to the furnace. Remove the blower compartment access door to examine the air filter(s) and blower for blockages or a loose blower wheel. (On the highboy and horizontal / downflow furnaces, air filters should be mounted external to the furnace casing.) If possible, correct the condition by cleaning or replacing the air filter(s), freeing the blower wheel of any foreign materials, or securing the blower wheel to the fan motor shaft. **Always replace the blower compartment access door when service is finished.** Restore electrical power to the furnace.

ROOM COMFORT CONTROL

Most room Comfort Controls are equipped with user adjustable, or selectable, levels of heat anticipation. This feature helps to reduce the amount of room air temperature overshoot that occurs after a heating cycle.

To adjust the heat anticipator, measure the electrical current output of the oil burner primary safety control to the room Comfort Control. (If measurement is not possible, the value of current output may be marked on the cover of the control). Set the Comfort Control heat anticipator to match the electrical current output of the oil primary safety control.

ELECTRICAL DIAGRAMS FOR PSC 4 SPEED BLOWER DOWNFLOW / HORIZONTAL FURNACES

LADDER SCHEMATIC

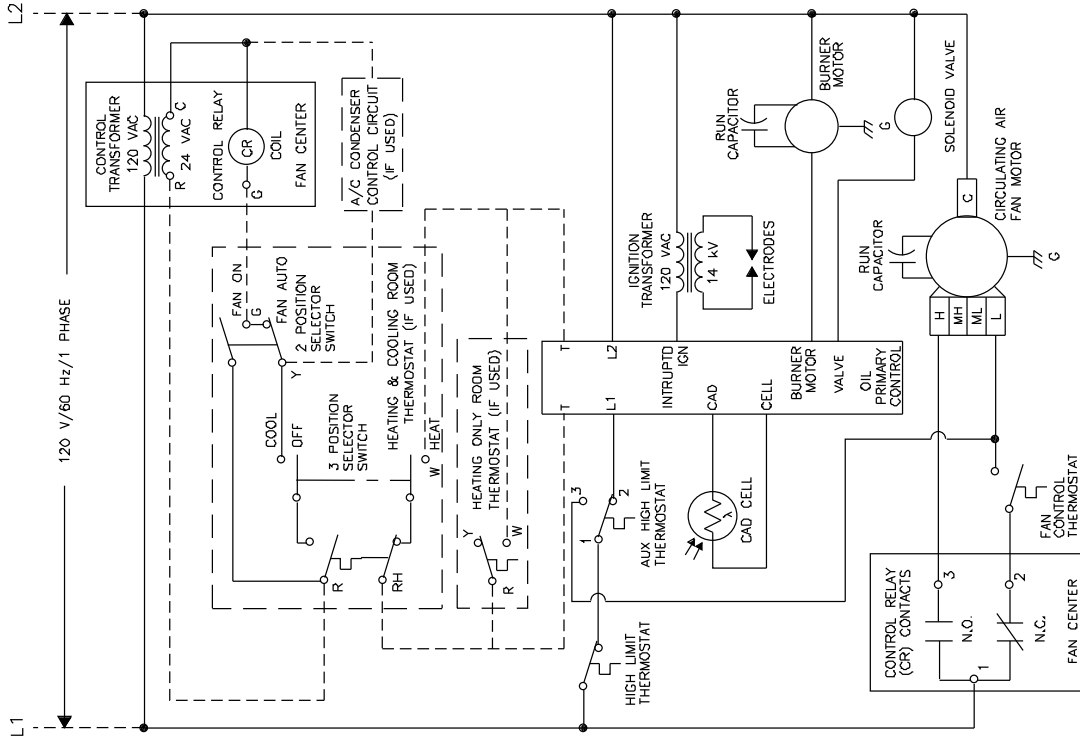

LEGEND
 - - - - - FIELD WIRING
 - - - - - FACTORY WIRING
 - - - - - MECHANICAL CONNECTION
 - - - - - COMPONENT NOT FURNISHED WITH FURNACE

CONNECTION DIAGRAM

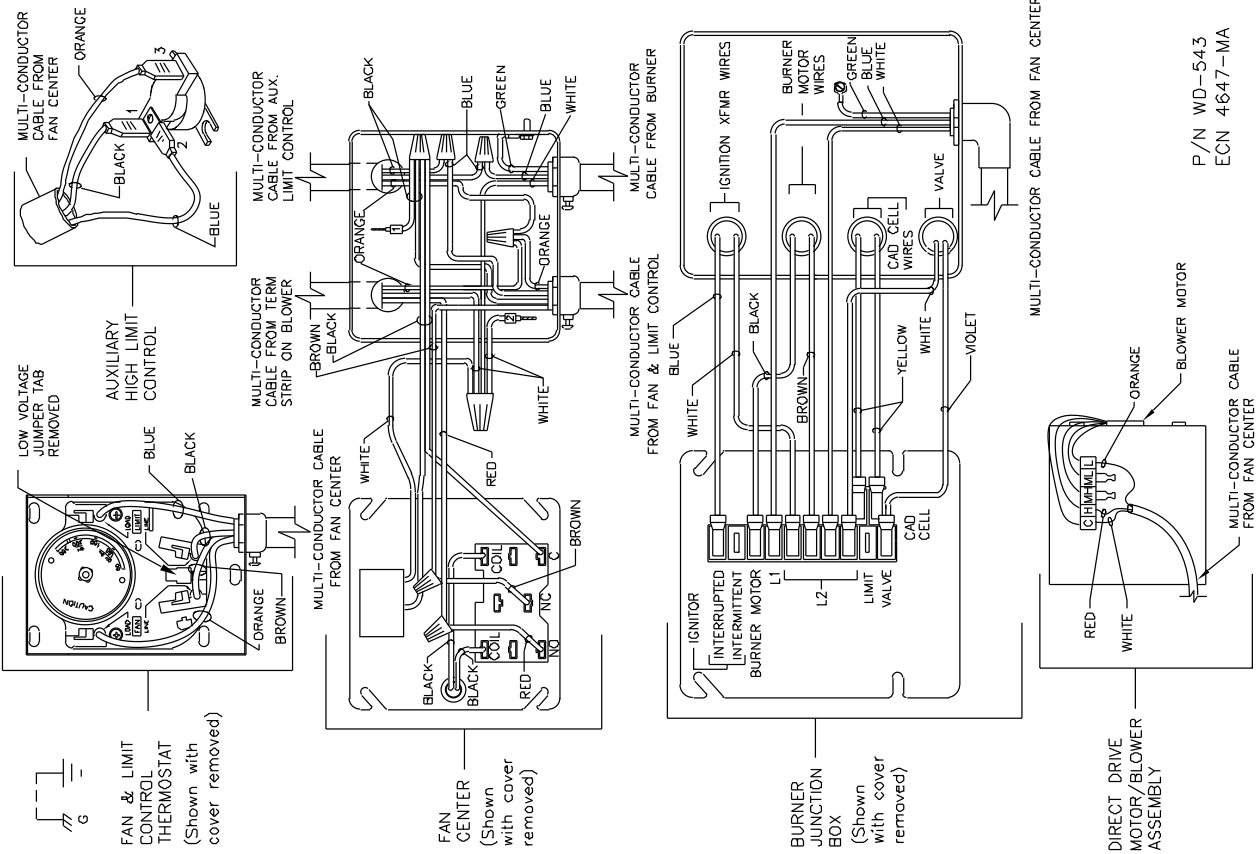

P/N WD-543
 ECN 4647-MA

ELECTRICAL DIAGRAMS FOR PSC 4 SPEED BLOWER HIGHBOY & LOWBOY FURNACES

LADDER SCHEMATIC

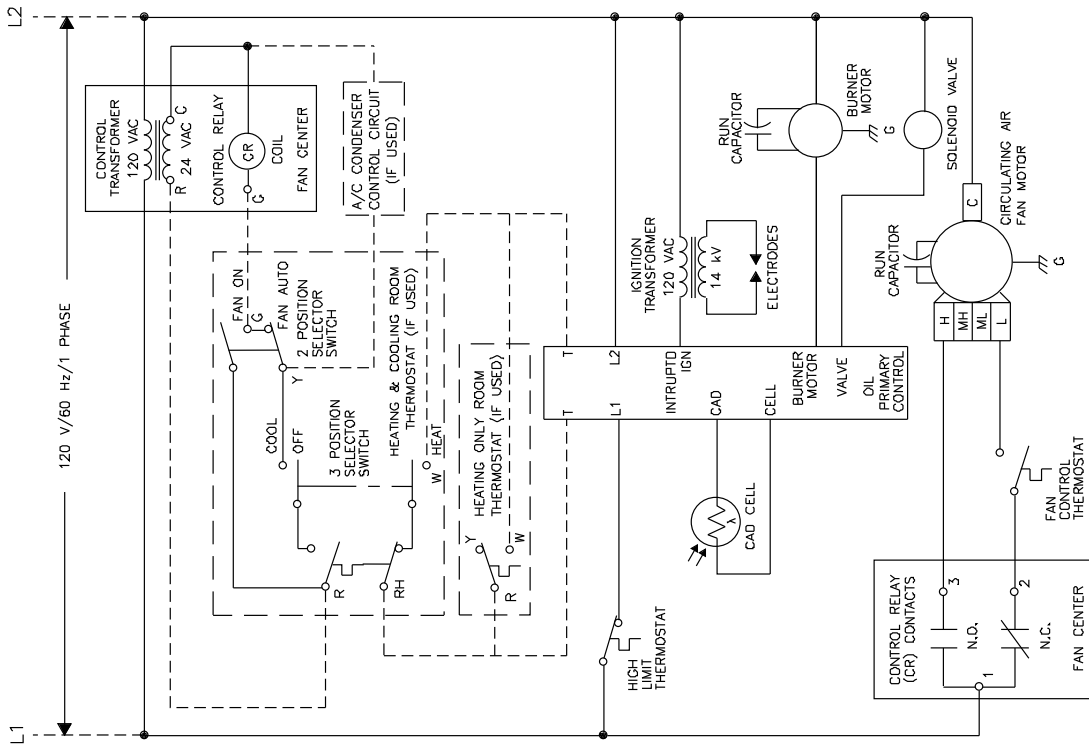

LEGEND

- FIELD WIRING
- FACTORY WIRING
- MECHANICAL CONNECTION
- COMPONENT NOT FURNISHED WITH FURNACE

CONNECTION DIAGRAM

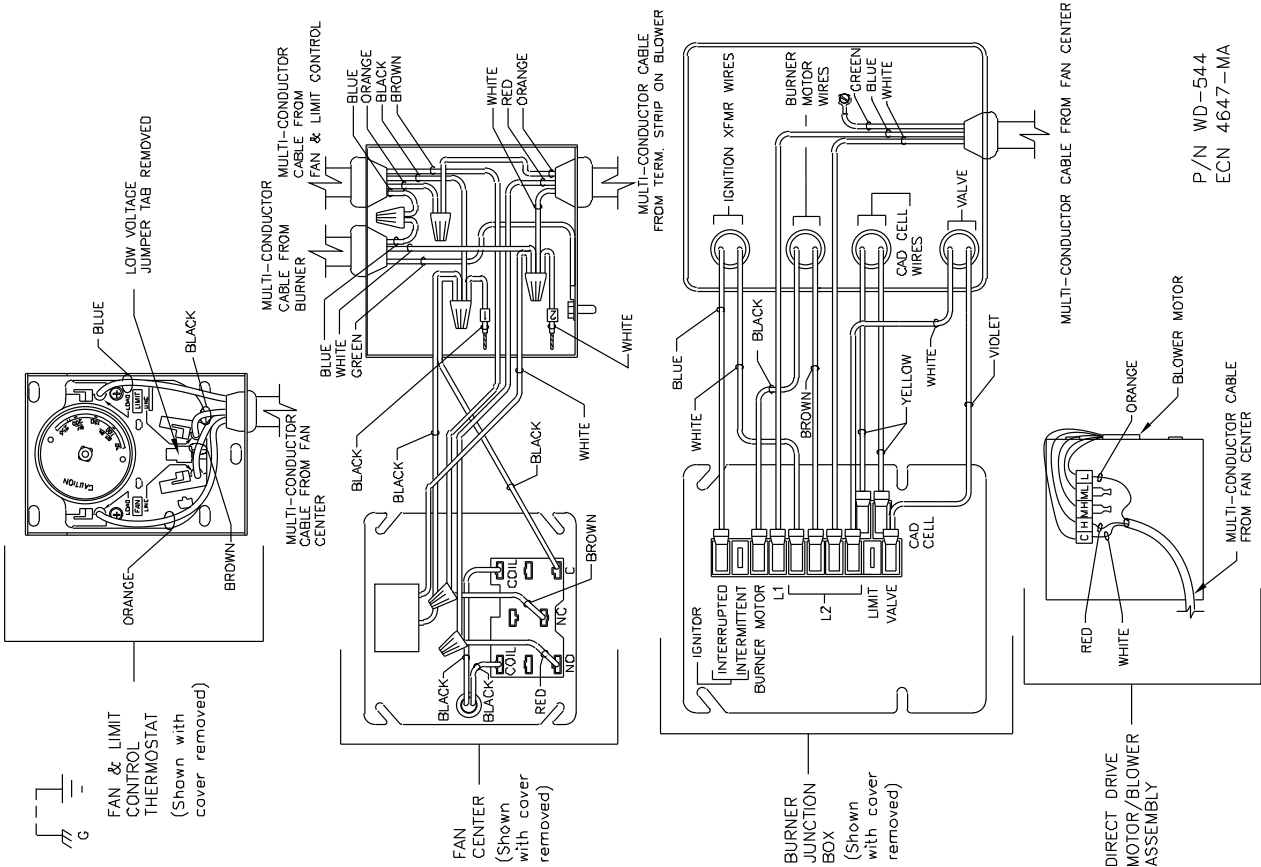

P/N WD-544
ECN 4647-MA



Trane
6200 Troup Highway
Tyler, TX 75707

For more information contact
your local dealer (distributor)

Since the manufacturer has a policy of continuous product and product data improvement, it reserves the
right to change design and specifications without notice.