

## GMT SERIES 80% AFUE

### Induced Draft 3-Way Multi-Position Gas Furnace



*The GMT multi-position upflow gas furnace is ready for utility room, closet, alcove, basement or attic applications.*

#### Standard Features

- Corrosion-resistant, aluminized-steel tubular heat exchanger
- Aluminized steel inshot burners
- 40VA transformer for heating and air conditioning control service
- Quiet, corrosion-resistant induced draft blower assembly
- Multiple flame roll-out switches
- Integrated furnace control with diagnostics
- Blower door safety switch
- Energy-saving Hot Surface Ignition system
- Outlet air-limit switch
- Pressure switch for proof of combustion air
- Energy-saving PSC, multi-speed, direct drive blower motors
- Multi-position capable—upflow, horizontal right or horizontal left
- Combination redundant gas valve and regulator
- Completely assembled, factory run-tested furnace for heating or combination heating/cooling application
- All model design certified by ITS to be in compliance with ANSI Z21.47 and CAN/CSA 2.3 (Canada) safety standards

#### Cabinet Construction

- Heavy-gauge, reinforced, wrap-around insulated steel cabinet with durable baked-enamel finish
- Convenient left or right connection for gas service
- Convenient left- or right-side electrical service
- Removable, solid-bottom block off
- Bottom or side air inlets

#### Optional Equipment

- L.P. Conversion Kit (LPT-00A)



# PRODUCT SPECIFICATIONS

## Performance Ratings

Model	Natural Gas Input* BTUH	Heating Capacity BTUH		DOE** AFUE	Temperature Rise Range (°F)
		Natural	LP		
GMT045-3B	45,000	36,000	32,000	80.0	25 - 55
GMT070-3B	70,000	56,000	48,000	80.0	25 - 55
GMT070-4B	70,000	56,000	48,000	80.0	20 - 50
GMT090-3B	90,000	72,000	64,000	80.0	30 - 60
GMT090-4B	90,000	72,000	64,000	80.0	35 - 65
GMT090-5B	90,000	72,000	64,000	80.0	35 - 65
GMT115-5B	115,000	92,000	80,000	80.0	35 - 65
GMT140-5D	140,000	112,000	96,000	80.0	40 - 70

\* For altitudes above 2,000', reduce input rating 4% for each 1,000' above sea level.

\*\* DOE AFUE based upon Isolated Combustion System (ICS).

## Specification Data

Model	Circulator Blower			Minimum Vent Diameter <sup>1</sup>	Filter Size (in <sup>2</sup> )		Minimum Circuit Ampacity <sup>2</sup> (Amps)	Maximum Overcurrent Protection <sup>3</sup> (Amps)	Shipping Weight (lbs.)
	Size (D x W)	HP	No. of Speeds		Permanent	Disposable			
GMT045-3B	10" x 6"	1/3	4	4"	290	580	8.1	15	120
GMT070-3B	10" x 6"	1/3	4	4"	290	580	8.1	15	130
GMT070-4B	10" x 8"	1/2	4	4"	385	770	12.5	15	143
GMT090-3B	10" x 8"	1/3	4	4"	290	580	8.1	15	153
GMT090-4B	10" x 8"	1/2	4	4"	385	770	12.5	15	153
GMT090-5B	10" x 10"	1/2	4	4"	480	960	12.5	15	163
GMT115-5B	10" x 10"	1/2	4	4"	480	960	12.5	15	163
GMT140-5D	10" x 10"	3/4	4	4"	480	960	14.7	15	183

<sup>1</sup> Vent and combustion air diameters may vary depending upon vent length. Refer to furnace installation instructions.

<sup>2</sup> Minimum Circuit Ampacity = (1.25 x Circulator Blower Amps) + ID Blower amps.

<sup>3</sup> Maximum Overcurrent Protection refers to maximum recommended fuse or circuit breaker size.

### NOTES:

- All furnaces are manufactured for use on 115 VAC, 60 Hz, single phase electrical supply.
- Gas Service Connection 1/2" FPT.
- Important: It is required to size fuses and wires properly and make electrical connections in accordance with the National Electrical Code and/or all existing local codes.

## Dimensions

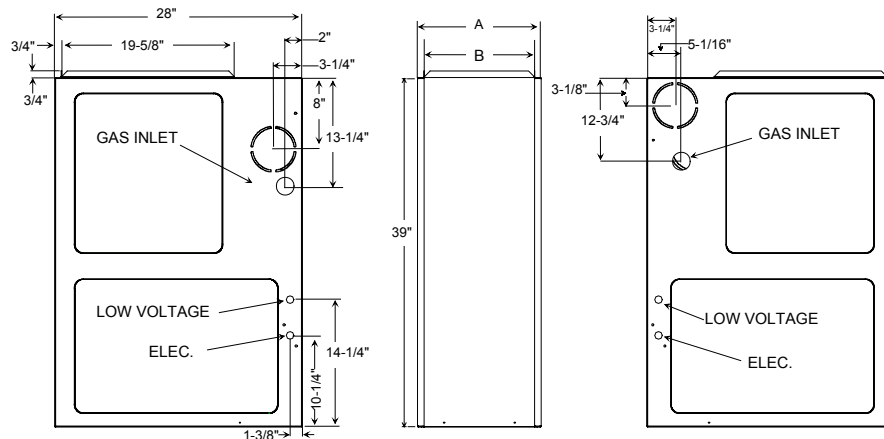

Model	A	B
GMT045-3B	14"	12 1/2"
GMT070-3B		
GMT070-4B	17 1/2"	16"
GMT090-3B		
GMT090-4B		
GMT090-5B	21"	19 1/2"
GMT115-5B		
GMT140-5D	24 1/2"	23"

### Minimum Clearances to Combustible Materials

Sides	Rear	Front*	Vent**		Top
			SW	B	
1	0	3	6	1	1

Approved for line contact in the horizontal position.

\*36" clearance for serviceability recommended.

\*\*Single Wall Vent (SW) to be used only as a connector. Refer to the venting tables outlined in the Installation Manual for additional venting requirements.

# Blower Performance

GMT Blower Performance (CFM & Temperature Rise vs. External Static Pressure)															
Model (Heating Speed As Shipped)	Motor Speed	Tons AC @ 0.5" ESP	External Static Pressure, (Inches Water Column)												
			0.1		0.2		0.3		0.4		0.5		0.6	0.7	0.8
			CFM	Rise	CFM	Rise	CFM	Rise	CFM	Rise	CFM	Rise	CFM	CFM	CFM
GMT045-3B (MED-LO)	HIGH	3.0	1,555	-----	1,511	-----	1,459	-----	1,392	-----	1,344	25	1,279	1,201	1,120
	MED	2.5	1,165	28	1,123	30	1,100	30	1,090	30	1,048	32	1,017	970	903
	MED-LO	2.0	927	36	907	37	889	37	863	38	853	39	822	800	746
	LOW	1.5	699	47	694	48	668	50	645	51	636	52	592	566	524
GMT070-3B (HIGH)	HIGH	3.0	1,437	36	1,310	39	1,295	40	1,310	39	1,273	41	1,202	1,129	1,039
	MED	2.5	1,127	46	1,100	47	1,095	47	1,075	48	1,050	49	1,018	967	904
	MED-LO	2.0	895	-----	917	-----	878	-----	867	-----	853	-----	830	786	743
	LOW	1.5	694	-----	681	-----	663	-----	640	-----	625	-----	591	562	522
GMT070-4B (MED-LO)	HIGH	4.0	2,234	23	2,151	24	2,076	25	1,990	26	1,897	27	1,803	1,710	1,569
	MED	3.5	1,676	31	1,653	31	1,648	31	1,581	33	1,555	33	1,492	1,414	1,352
	MED-LO	3.0	1,342	38	1,335	39	1,321	39	1,313	39	1,291	40	1,261	1,215	1,149
	LOW	2.5	1,089	47	1,085	48	1,078	48	1,071	48	1,057	49	1,040	986	932
GMT090-3B (HIGH)	HIGH	3.0	1,593	42	1,561	43	1,567	42	1,543	43	1,493	44	1,420	1,343	1,230
	MED	2.5	1,186	56	1,160	57	1,160	57	1,135	58	1,118	59	1,089	1,045	983
	MED-LO	2.0	957	-----	940	-----	937	-----	921	-----	895	-----	861	826	778
	LOW	1.5	742	-----	710	-----	685	-----	663	-----	635	-----	611	578	476
GMT090-4B (MED-LO)	HIGH	4.0	2,251	-----	2,169	31	2,084	32	1,986	33	1,891	35	1,773	1,688	1,537
	MED	3.5	1,659	40	1,653	40	1,648	40	1,605	41	1,555	43	1,485	1,405	1,313
	MED-LO	3.0	1,364	49	1,349	49	1,347	49	1,340	50	1,313	51	1,260	1,212	1,130
	LOW	2.5	1,104	60	1,098	60	1,092	61	1,083	61	1,080	61	1,040	1,001	945
GMT090-5B (MED-LO)	HIGH	5.0	2,276	-----	2,176	-----	2,079	-----	1,986	-----	1,886	35	1,788	1,688	1,551
	MED	4.0	1,723	39	1,713	39	1,679	40	1,639	40	1,589	42	1,510	1,430	1,339
	MED-LO	3.5	1,411	47	1,412	47	1,403	47	1,369	48	1,325	50	1,274	1,219	1,137
	LOW	3.0	1,142	58	1,127	59	1,128	59	1,108	60	1,078	62	1,053	993	926
GMT115-5B (MED)	HIGH	5.0	2,481	-----	2,395	35	2,288	37	2,217	38	2,076	41	1,999	1,858	1,732
	MED	4.0	1,738	49	1,732	49	1,709	50	1,686	50	1,639	52	1,585	1,492	1,385
	MED-LO	3.5	1,364	62	1,378	62	1,372	62	1,372	62	1,350	63	1,313	1,261	1,125
	LOW	3.0	1,137	-----	1,142	-----	1,140	-----	1,114	-----	1,090	-----	1,056	954	860
GMT140-5D (MED)	HIGH	5.0	2,554	41	2,435	43	2,375	44	2,240	47	2,152	49	2,002	1,883	1,744
	MED	4.0	1,846	57	1,773	59	1,762	60	1,712	61	1,672	63	1,583	1,526	1,442
	MED-LO	3.5	1,520	69	1,500	70	1,483	-----	1,470	-----	1,435	-----	1,373	1,308	1,245
	LOW	3.0	1,301	-----	1,274	-----	1,260	-----	1,231	-----	1,207	-----	1,177	1,093	931

1. CFM in chart is without filter(s). Filters do not ship with this furnace, but must be provided by the installer. If the furnace requires two returns, this chart assumes both filters are installed.
2. All furnaces ship as high speed cooling. Installer must adjust blower cooling speed as needed.
3. For most jobs, about 400 CFM per ton when cooling is desirable.
4. INSTALLATION IS TO BE ADJUSTED TO OBTAIN TEMPERATURE RISE WITHIN THE RANGE SPECIFIED ON THE RATING PLATE.
5. The chart is for information only. For satisfactory operation, external static pressure must not exceed value shown on the rating plate. The shaded area indicates ranges in excess of maximum static pressure allowed when heating.
6. The dashed (----) areas indicate a temperature rise not recommended for this model.
7. The above chart is for U.S. furnaces installed at 0-2000 feet. At higher altitudes, a properly derated unit will have approximately the same temperature rise at a particular CFM, while ESP at the CFM will be lower.

PRODUCT SPECIFICATIONS

Cased U Coil Application Options

Coil Model Number Coil Width		COIL MODELS													
		U-18	U-29	U-30	U-31	U-32	U-35	U-36	U-42	U-47	U-49	U-59	U-60	U-61	U-62
		14"	14"	17½"	14"	17½"	14"	17½"	17½"	17½"	21"	21"	24½"	24½"	21"
Models	Furnace Width														
GMT045-3B GMT070-3B	14"	x	x	x <sup>(1)</sup>	x	x <sup>(1)</sup>	x	x <sup>(1)</sup>	x <sup>(1)</sup>						
GMT070-4B GMT090-3B GMT090-4B	17½"			x <sup>(2)</sup>		x <sup>(2)</sup>		x <sup>(2)</sup>	x <sup>(2)</sup>	x	x <sup>(1)</sup>	x <sup>(1)</sup>			x <sup>(1)</sup>
GMT090-5B GMT115-5B	21"											x <sup>(2)</sup>	x <sup>(1)</sup>	x <sup>(1)</sup>	x <sup>(2)</sup>
GMT140-5D	24½"												x <sup>(2)</sup>	x <sup>(2)</sup>	

1. Using the factory-installed bottom cabinet filler plates
2. Discard bottom cabinet filler plates

Due to the rating mix/match of various coils with outdoor units, it is important to match the furnace air flow for the total system capacity. Refer to furnace, heat pump and/or condensing unit specification sheets.



Goodman Manufacturing Company, L.P., reserves the right to discontinue, or change at any time, specifications or designs without notice or without incurring obligations.  
 Copyright © 2003 Goodman Manufacturing Company, L.P. • Houston, Texas • Printed in the USA. • Goodman products are made proudly in the USA.