



# Split-type Air-Conditioner

MXZ-3A30NA

MXZ-4A36NA

## INSTALLATION MANUAL

- Refer to the installation manual of each indoor unit for indoor unit installation.

English

Français

Español

### ATTENTION

This manual mentions how to install only the outdoor unit (MXZ-3A30NA, MXZ-4A36NA). As for the way of installation for indoor unit, please refer to the installation manual being attached each indoor unit.

The installation manual details the suggested installation method.

Any structural alterations necessary for installation must comply with local building code requirements.

### CONTENTS

1. BEFORE INSTALLATION .....	2
2. OUTDOOR UNIT INSTALLATION .....	5
3. FLARING WORK AND PIPE CONNECTION.....	7
4. PURGING PROCEDURES, LEAK TEST, AND TEST RUN.....	8

FOR INSTALLER

# 1. BEFORE INSTALLATION

## 1-1. THE FOLLOWING SHOULD ALWAYS BE OBSERVED FOR SAFETY

- Be sure to read "THE FOLLOWING SHOULD ALWAYS BE OBSERVED FOR SAFETY" before installing the air conditioner.
- Be sure to observe the warnings and cautions specified here as they include important items related to safety.
- After reading this manual, be sure to keep it together with the OPERATING INSTRUCTIONS for future reference.

### ⚠ WARNING (Could lead to death, serious injury, etc.)

- **Do not install the unit by yourself (user).**  
Incomplete installation could cause fire or electric shock, injury due to the unit falling, or leakage of water. Consult the dealer from whom you purchased the unit or a qualified installer.
- **Perform the installation securely referring to the installation manual.**  
Incomplete installation could cause fire or electric shock, injury due to the unit falling, or leakage of water.
- **Install the unit securely in a place which can bear the weight of the unit.**  
If the installation location cannot bear the weight of the unit, the unit could fall causing injury.
- **Perform electrical work according to the installation manual and be sure to use an exclusive circuit. Do not connect other electrical appliances to the circuit.**  
If the capacity of the power circuit is insufficient or there is incomplete electrical work, it could result in a fire or an electric shock.
- **Do not damage the wires by applying excessive pressure with parts or screws.**  
Damaged wires could cause fire.
- **Be sure to cut off the main power in case of setting up the indoor P.C. board or wiring works.**  
Failure to do so could cause electric shock.
- **Use the specified wires to connect the indoor and outdoor units securely and attach the wires firmly to the terminal block connecting sections so the stress of the wires is not applied to the sections.**  
Incomplete connecting and securing could cause fire.
- **Do not install the unit in a place where inflammable gas may leak.**  
If gas leaks and accumulates in the area around the unit, it could cause an explosion.
- **Do not use intermediate connection of the power cord or the extension cord and do not connect many devices to one AC outlet.**  
It could cause a fire or an electric shock due to defective contact, defective insulation, exceeding the permissible current, etc.
- **Be sure to use the parts provided or specified parts for the installation work.**  
The use of defective parts could cause an injury or leakage of water due to a fire, an electric shock, the unit falling, etc.
- **When plugging the power supply plug into the outlet, make sure that there is no dust, clogging, or loose parts in both the outlet and the plug. Make sure that the power supply plug is pushed completely into the outlet.**  
If there is dust, clogging, or loose parts on the power supply plug or the outlet, it could cause electric shock or fire. If loose parts are found on the power supply plug, replace it.
- **Attach the electrical cover to the indoor unit and the service panel to the outdoor unit securely.**  
If the electrical cover of the indoor unit and/or the service panel of the outdoor unit are not attached securely, it could result in a fire or an electric shock due to dust, water, etc.
- **When installing or relocating the unit, make sure that no substance other than the specified refrigerant (R410A) enters the refrigerant circuit.**  
Any presence of foreign substance such as air can cause abnormal pressure rise or an explosion.
- **Do not discharge the refrigerant into the atmosphere. If refrigerant leaks during installation, ventilate the room.**  
If refrigerant comes in contact with a fire, harmful gas could be generated.
- **Check that the refrigerant gas does not leak after installation has been completed.**  
If refrigerant gas leaks indoors, and comes into contact with the flame of a fan heater, space heater, stove, etc., harmful substances will be generated.
- **Use appropriate tools and piping materials for installation.**  
The pressure of R410A is 1.6 times more than R22. Not using appropriate tools or materials and incomplete installation could cause the pipes to burst or injury.
- **When pumping down the refrigerant, stop the compressor before disconnecting the refrigerant pipes.**  
If the refrigerant pipes are disconnected while the compressor is running and the stop valve is open, air could be drawn in and the pressure in the refrigeration cycle could become abnormally high. This could cause the pipes to burst or injury.
- **When installing the unit, securely connect the refrigerant pipes before starting the compressor.**  
If the compressor is started before the refrigerant pipes are connected and when the stop valve is open, air could be drawn in and the pressure in the refrigeration cycle could become abnormally high. This could cause the pipes to burst or injury.
- **Fasten a flare nut with a torque wrench as specified in this manual.**  
If fastened too tight, a flare nut may break after a long period and cause refrigerant leakage.
- **The unit shall be installed in accordance with national wiring regulations.**
- **Ground the unit correctly.**  
Do not connect the ground to a gas pipe, water pipe, lightning rod or telephone ground. Defective grounding could cause electric shock.

### ⚠ CAUTION (Could lead to serious injury in particular environments when operated incorrectly.)

- **Install an ground leakage breaker depending on the installation place.**  
If an ground leakage breaker is not installed, it could cause electric shock.
- **Perform the drainage/piping work securely according to the installation manual.**  
If there is defect in the drainage/piping work, water could drop from the unit, soaking and damaging household goods.
- **Do not touch the air inlet or the aluminum fins of the outdoor unit.**  
This could cause injury.
- **Do not install the outdoor unit where small animals may live.**  
If small animals enter and touch the electric parts inside the unit, it could cause a malfunction, smoke emission, or fire. Also, advise user to keep the area around the unit clean.

## 1-2. REQUIRED TOOLS FOR INSTALLATION

Phillips screwdriver  
Level  
Scale  
Utility knife or scissors

Torque wrench  
Wrench (or spanner)  
4 mm (5/32 in.) hexagonal wrench  
Flare tool for R410A

Gauge manifold for R410A  
Vacuum pump for R410A  
Charge hose for R410A  
Pipe cutter with reamer

## 1-3. SPECIFICATIONS

Model	Power supply		Pipe length and height difference *2, *3, *4, *8			
	Rated Voltage	Frequency	Max. pipe length per indoor unit / for multi-system	Max. height difference	Max. no. of bends per indoor unit / for multi system	Refrigerant adjustment A *5
MXZ-3A30NA MXZ-4A36NA	208/ 230 V	60 Hz	25 m (82 ft) / 70 m (230 ft)	15 m (49 ft)	25 / 70	20 g/m (1.06 oz each 5 ft)

\*1 Never use pipes with thickness less than specified. The pressure resistance will be insufficient.

\*2 Use a copper pipe or a copper-alloy seamless pipe.

\*3 Be careful not to crush or bend the pipe during pipe bending.

\*4 Refrigerant pipe bending radius must be 100 mm (4 in.) or more.

\*5 If pipe length exceeds 40 m (131 ft), additional refrigerant (R410A) charge is required. (No additional charge is required for pipe length less than 40 m (131 ft).)

$$\text{Additional refrigerant (m)} = A \times (\text{pipe length (m)} - 40)$$

$$\text{Additional refrigerant (ft)} = A \times \frac{(\text{pipe length (ft)} - 131)}{5}$$

\*6 Insulation material : Heat resisting foam plastic 0.045 specific gravity

\*7 Be sure to use the insulation of specified thickness. Excessive thickness may cause incorrect installation of the indoor unit and insufficient thickness may cause dew drippage.

\*8 If the outdoor unit is installed higher than the indoor unit, max. height difference is reduced to 10 m (33 ft).

## 1-4. SELECTING PIPE SIZE AND OPTIONAL DIFFERENT-DIAMETER JOINTS

The diameter of connection pipes differs according to the type and capacity of indoor units. Match the diameters of connection pipes for indoor and outdoor units according to the following table.

- If the diameter of connection pipes does not match the diameter of pipe end connections, use optional different-diameter joints.

Outdoor unit	Pipe size (liquid / gas)	Indoor unit		
		09/12	15/17	24
		6.35 (1/4) / 9.52 (3/8)	6.35 (1/4) / 12.7 (1/2)	6.35 (1/4) / 15.88 (5/8)
A UNIT	6.35 (1/4) / 12.7 (1/2)	- / MAC-A455JP	- / -	- / MAC-A456JP
B UNIT				
C UNIT	6.35 (1/4) / 9.52 (3/8)	- / -	- / MAC-454JP	- / PAC-SG76RJ
D UNIT *				

\* MXZ-4A36NA only

## 1-5. SELECTING THE INSTALLATION LOCATION

- Where it is not exposed to strong wind.
- Where airflow is good and dustless.
- Where rain or direct sunshine can be avoided as much as possible.
- Where neighbours are not annoyed by operation sound or hot air.
- Where rigid wall or support is available to prevent the increase of operation sound or vibration.
- Where there is no risk of combustible gas leakage.
- When installing the unit at a high level, be sure to secure the unit legs.
- Where it is at least 3 m (9.84 ft) away from the antenna of TV set or radio. Operation of the air conditioner may interfere with radio or TV reception in areas where reception is weak. An amplifier may be required for the affected device.
- Install the unit horizontally.
- Please install it in an area not affected by snowfall or blowing snow. In areas with heavy snow, please install a canopy, a pedestal and/or some baffle boards.

### Note:

It is advisable to make a piping loop near outdoor unit so as to reduce vibration transmitted from there.

### Note:

When operating the air conditioner in low outside temperature, be sure to follow the instructions described below.

- Never install the outdoor unit in a place where its air inlet/outlet side may be exposed directly to wind.
- To prevent exposure to wind, install the outdoor unit with its air inlet side facing the wall.
- To prevent exposure to wind, it is recommended to install a baffle board on the air outlet side of the outdoor unit.

Avoid the following places for installation where air conditioner trouble is liable to occur.

- Where flammable gas could leak.
- Where there is much machine oil.
- Salty places such as the seaside.
- Where sulfide gas is generated such as a hot spring.
- Where there is high-frequency or wireless equipment.

## FREE SPACE REQUIRED AROUND OUTDOOR UNIT

### 1. Top side obstacles

When there is an obstacle behind the rear side only, it does not matter if there is an obstacle over the top side as shown in the figure below.

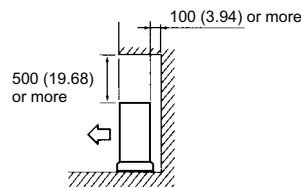

### 2. Front (blowing) side open

As long as space like the one shown in the figure can be maintained, it does not matter if there are obstacles in three directions (but top side is open).

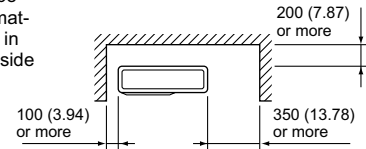

### 3. Obstacles on front (blowing) side only

In this case, the rear, both sides and top should be open.

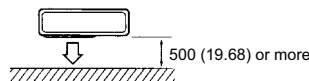

### 4. Obstacles on front and rear side only

The unit can be used by attaching an optional outdoor blowing guide (MAC-855SG) (but both sides and top are open).

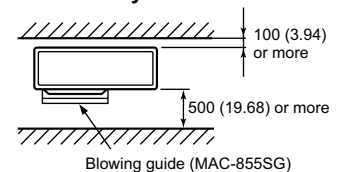

### 5. Service space

Keep the service space as shown in the figure below for maintenance.

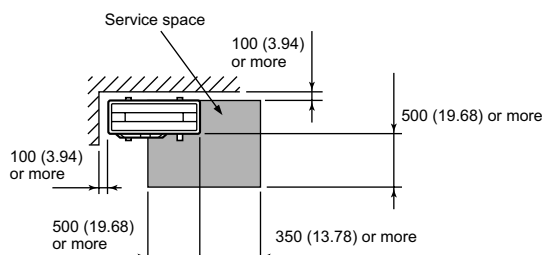

- When installing the unit in an area that is enclosed on four sides such as a verandah, be sure to leave more than 200 mm (7.87 in.) behind the unit as shown.
- When there is a lack of airflow or there is a possibility of becoming short cycle, install an outlet guide and make sure there is enough space behind the rear side of the air inlet.

### Note:

Make sure not to install several outdoor units sideways next to each other.

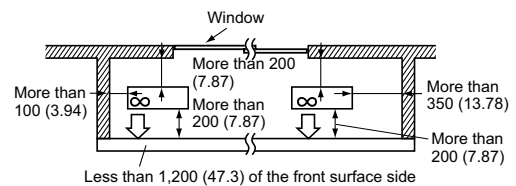

[Unit: mm (inch)]

## 1-6. INSTALLATION DIAGRAM

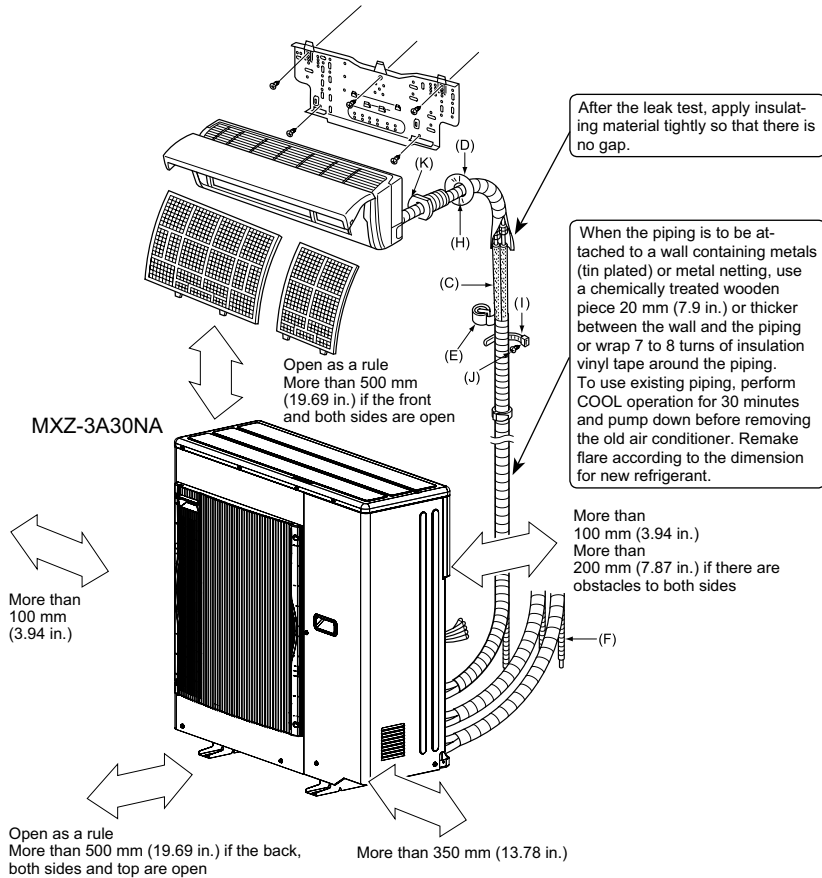

Units should be installed by licensed contractor according to local code requirements.

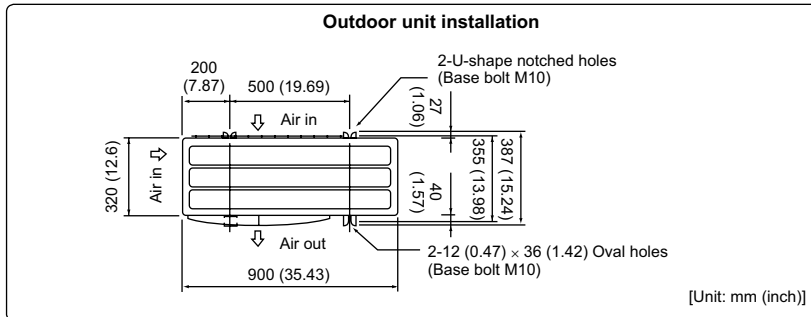

## 1-7. MOUNTING ARRANGEMENT OF DRAIN SOCKET

Please perform the drain piping work only when draining from one place.

- 1 Choose one hole to discharge drain and install the drain socket to the hole.
- 2 Close the rest of the holes with the drain caps.
- 3 Connect a vinyl hose of 25 mm (31/32 in.) in the inside diameter on the market with the drain socket and lead drain.

### Note:

Do not use the drain socket and the drain cap in the cold region. Drain may freeze and it makes the fan stop.

## PARTS TO BE PROVIDED AT YOUR SITE

(A)	Power supply cord*	1
(B)	Indoor/outdoor unit connecting wire*	1
(C)	Extension pipe (Refer to 1-4.)	1
(D)	Wall hole cover	1
(E)	Piping tape	1
(F)	Extension drain hose (or soft PVC hose, 15 mm (19/32 in.) inner diameter or hard PVC pipe VP16)	1
(G)	Refrigeration oil	Little amount
(H)	Putty	1
(I)	Pipe fixing band	2 to 7
(J)	Fixing screw for (I)	2 to 7
(K)	Wall hole sleeve	1
(L)	Soft PVC hose, 25 mm (31/32 in.) inner diameter or hard PVC pipe VP25 for drain socket	1

### \* Note:

Place indoor/outdoor unit connecting wire (B) and power supply cord (A) at least 1 m (39.4 in.) away from the TV antenna wire.

The "Q'ty" for (B) to (K) in the above table is quantity to be used per indoor unit.

## 2. OUTDOOR UNIT INSTALLATION

### 2-1. INSTALLING THE UNIT

- Be sure to fix the unit's legs with bolts when installing it.
- Be sure to install the unit firmly to ensure that it does not fall by an earthquake or a gust.
- Refer to the figure in the right for concrete foundation.
- Do not use the drain socket and the drain cap in the cold region.  
Drain may freeze and it makes the fan stop.

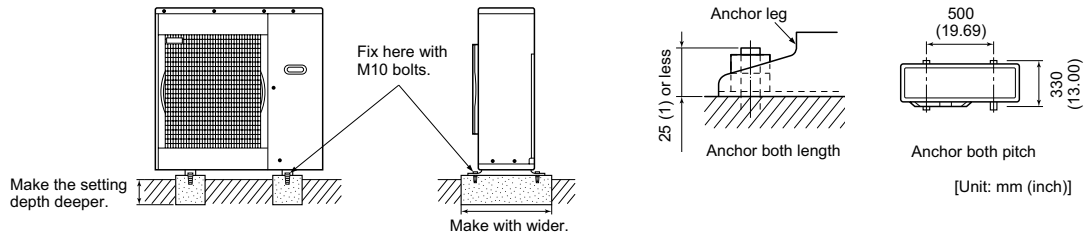

### 2-2. CONNECTING WIRES FOR OUTDOOR UNIT

- Be sure to use special circuits for room air conditioner.
- Wiring work should be based on applicable technical standards.
- Wiring connections should be made following the diagram.
- Screws should be tightened so they won't loosen.

OUTDOOR UNIT		ELECTRICAL SPECIFICATIONS	
		MXZ-3A30NA	MXZ-4A36NA
Power supply (V, PHASE, Hz)		208/230, 1, 60	
Max. Fuse size (time delay) (A)		20	20
Min. Circuit Ampacity (A)		15	19
Fan motor (F.L.A)		0.93	0.93
Compressor	(R.L.A)	11	14.4
	(L.R.A)	15	15
Control voltage		Indoor unit-Remote controller : (Wireless) Indoor unit-Outdoor unit : DC12-24V	

- 1) Remove the service panel.
- 2) Fix the conduit connector to conduit cover with lock nut then secure it against unit with screws.
- 3) Fix the conduit cover to the outdoor unit then secure it with screws.
- 4) Connect power supply cord and indoor/outdoor connecting wire to the terminal block.  
(Leave some slack in wires to allow easier servicing.)
- 5) Close the service panel securely. Make sure that 3-2. PIPE CONNECTION is completed.

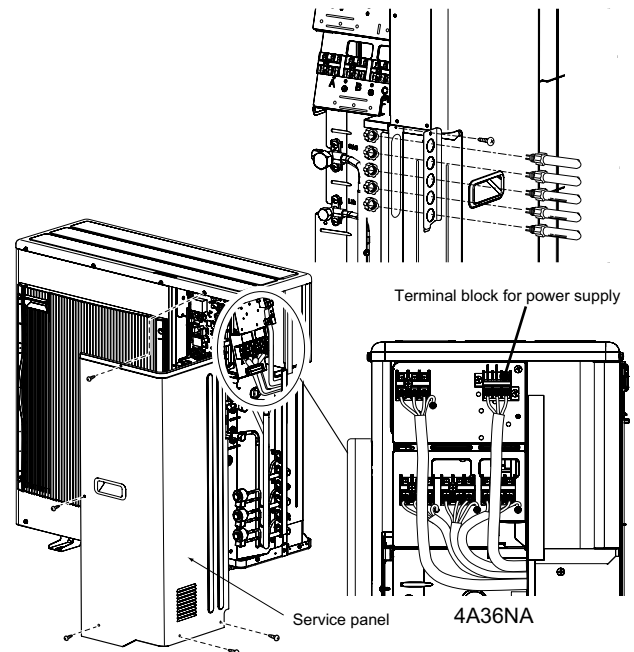

#### Connecting order

- Connect the terminal block in order, from the A, B and C unit side.

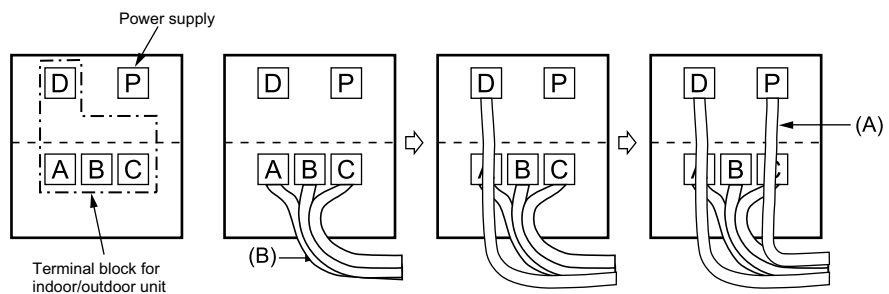



### 3. FLARING WORK AND PIPE CONNECTION

#### 3-1. FLARING WORK

- 1) Cut the copper pipe correctly with pipe cutter. (Fig. 1, 2)
- 2) Completely remove all burrs from the cut cross section of pipe. (Fig. 3)
  - Put the end of the copper pipe to downward direction as you remove burrs in order to avoid to let burrs drop in the piping.
- 3) Remove flare nuts attached to indoor and outdoor units, then put them on pipe having completed burr removal. (Not possible to put them on after flaring work.)
- 4) Flaring work (Fig. 4, 5). Firmly hold copper pipe in the dimension shown in the table. Select A mm from the table according to the tool you use.
- 5) Check
  - Compare the flared work with Fig. 6.
  - If flare is noted to be defective, cut off the flared section and do flaring work again.

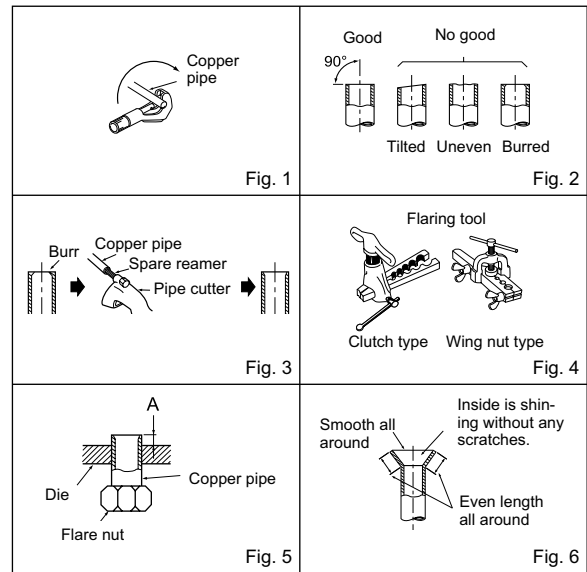

Pipe diameter [mm (inch)]	Nut (mm)	A [mm (inch)]			Tightening torque		
		Clutch type tool for R410A	Clutch type tool for R22	Wing nut type tool for R22	N•m	kgf•cm	ft-lb
ø6.35 (1/4)	17	0 to 0.5 (0. to 0.02)	1.0 to 1.5 (0.04 to 0.06)	1.5 to 2.0 (0.06 to 0.08)	13.7 to 17.7	140 to 180	10 to 13
ø9.52 (3/8)	22			2.0 to 2.5 (0.08 to 1.0)	34.3 to 41.2	350 to 420	25 to 30
ø12.7 (1/2)	26			49.0 to 56.4	500 to 575	36 to 42	
ø15.88 (5/8)	29			73.5 to 78.4	750 to 800	54 to 58	

#### 3-2. PIPE CONNECTION

- Fasten flare nut with a torque wrench as specified in the table.
- When fastened too tight, flare nut may brake after a long period and cause refrigerant leakage.

##### Outdoor unit connection

Connect pipes to stop valve pipe joint of the outdoor unit in the same manner applied for indoor unit.

- For tightening, use a torque wrench or spanner and use the same tightening torque applied for indoor unit.

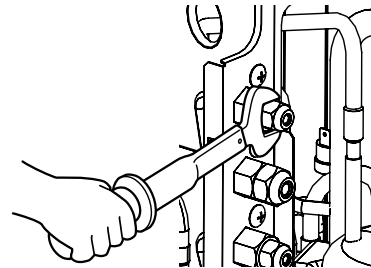

#### 3-3. INSULATION AND TAPING

- 1) Cover piping joints with pipe cover.
- 2) For outdoor unit side, surely insulate every piping including valves.
- 3) Using piping tape (E), apply taping starting from the entry of outdoor unit.
  - Stop the end of piping tape (E) with tape (with adhesive agent attached).
  - When piping have to be arranged through above ceiling, closet or where the temperature and humidity are high, wind additional commercially sold insulation to prevent condensation.

## 4. PURGING PROCEDURES, LEAK TEST, AND TEST RUN

### 4-1. PURGING PROCEDURES AND LEAK TEST

- 1) Remove service port cap of stop valve on the side of the outdoor unit gas pipe. (The stop valve will not work in its initial state fresh out of the factory, totally closed with cap on.)
- 2) Connect gauge manifold valve and vacuum pump to service port of stop valve on the gas pipe side of the outdoor unit.
- 3) Run the vacuum pump. (Vacuumize for more than 15 minutes.)
- 4) Check the vacuum with gauge manifold valve, then close gauge manifold valve, and stop the vacuum pump.
- 5) Leave as it is for one or two minutes. Make sure pointer gauge manifold valve remains in the same position. Confirm that pressure gauge shows  $-0.101\text{ MPa}$  [Gauge] [ $-760\text{ mmHg}$  ( $-30\text{ in. Hg}$ )].
- 6) Remove gauge manifold valve quickly from service port of stop valve.
- 7) After refrigerant pipes are connected and evacuated, fully open all stop valves on both sides of gas pipe and liquid pipe. Operating without fully opening lowers the performance and this causes trouble.
- 8) Refer to 1-4., and charge the prescribed amount of refrigerant if needed. Be sure to charge slowly with liquid refrigerant. Otherwise, composition of the refrigerant in the system may be changed and affect performance of the air conditioner.
- 9) Tighten cap of service port to obtain the initial status.
- 10) Leak test

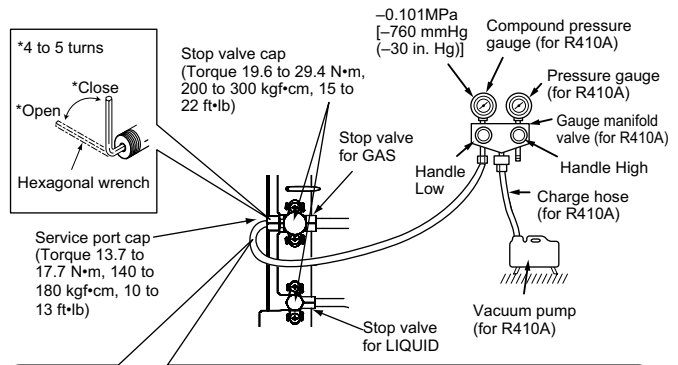

#### Precautions when using the control valve

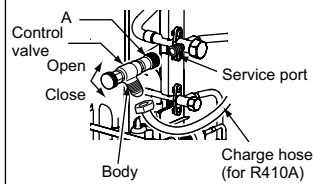

When attaching the control valve to the service port, valve core may deform or loosen if excess pressure is applied. This may cause gas leak.

When attaching the control valve to the service port, make sure that the valve core is in closed position, and then tighten part A. Do not tighten part A or turn the body when valve core is in open position.

### 4-2. GAS CHARGE

Perform gas charge to unit.

- 1) Connect gas cylinder to the service port of stop valve.
- 2) Perform air purge of the pipe (or hose) coming from refrigerant gas cylinder.
- 3) Replenish specified amount of the refrigerant, while operating the air conditioner for cooling.

#### Note:

In case of adding refrigerant, comply with the quantity specified for the refrigerating cycle.

#### CAUTION:

When charging the refrigerant system with additional refrigerant, be sure to use liquid refrigerant. Adding gas refrigerant may change the composition of the refrigerant in the system and affect normal operation of the air conditioner. Also, charge the system slowly, otherwise the compressor will be locked.

To maintain the high pressure of the gas cylinder, warm the gas cylinder with warm water [under  $40^{\circ}\text{C}$  ( $140^{\circ}\text{F}$ )] during cold season. But never use naked fire or steam.

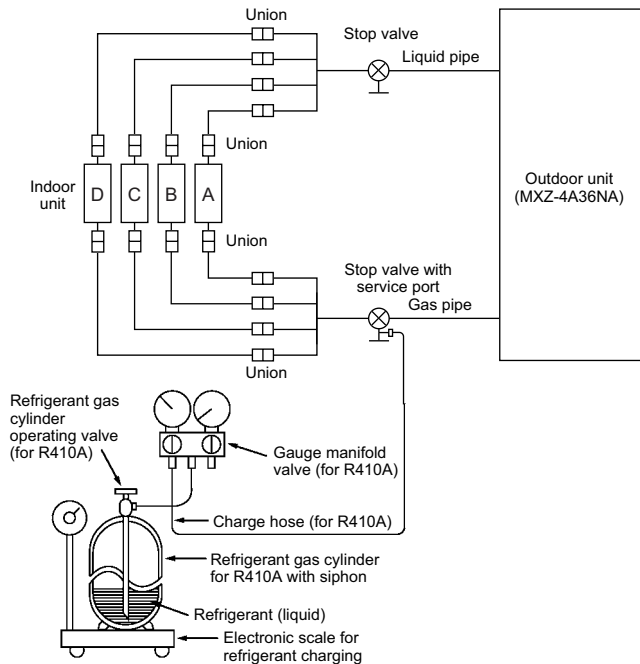



### 4-3. TEST RUN

- Be sure to perform the test run for each unit. Make sure each indoor unit operates properly following the installation manual attached to the unit.
- If you perform the test run for all indoor units at once, you cannot detect any erroneous connection, if any, of the refrigerant pipes and the indoor/outdoor unit connecting wires.

#### About the restart protective mechanism

Once the compressor stops, the restart preventive device operates so the compressor will not operate for 3 minutes to protect the air conditioner.

#### Wiring/piping correction function

This unit has a wiring/piping correction function which corrects wiring and piping combination. When there is possibility of incorrect wiring and piping combination, and confirming the combination is difficult, use this function to detect and correct the combination by following the procedures below.

Make sure that the following is done.

- Power is supplied to the unit.
- Stop valves are open.

#### Note:

During detection, the operation of the indoor unit is controlled by the outdoor unit. During detection, the indoor unit automatically stops operation. This is not a malfunction.

#### Procedure

Press the piping/wiring correction switch (SW871) 1 minute or more after turning on the power supply.

- Correction completes in 10 to 15 minutes. When the correction is completed, its result is shown by LED indication. Details are described in the following table.
- To cancel this function during its operation, press the piping/wiring correction switch (SW871) again.
- When the correction completed without error, do not press the piping/wiring correction switch (SW871) again.

When the result was "cannot be corrected", press the piping/wiring correction switch (SW871) again to cancel this function. Then, confirm the wiring and piping combination in a conventional manner by operating the indoor units one by one.

- The operation is done while the power is supplied. Make sure not to contact parts other than the switch, including the P.C. board. This may cause electric shock or burn by hot parts and live parts around the switch. Contacting the live parts may cause P.C. board damage.
- To prevent electronic control P.C. board damage, make sure to perform static elimination before operating this function.

- This function does not operate when the outside temperature is 0°C (32°F) or below.

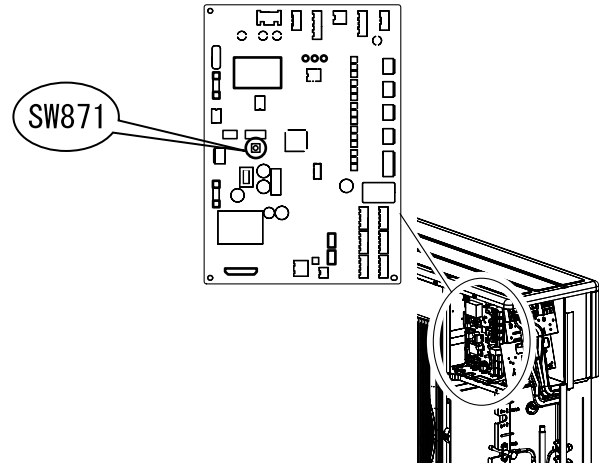

#### LED indication during detection:

LED		
1 (Red)	2 (Yellow)	3 (Green)
Lighted	Lighted	Blinking

#### Result of piping/wiring correction function

LED			Result
1 (Red)	2 (Yellow)	3 (Green)	
Lighted	Not lighted	Lighted	Completed (Corrected successfully)
Blinking	Blinking	Blinking	Cannot be corrected
Other indications			Refer to "SAFETY PRECAUTIONS WHEN LED FLASHES" located behind the service panel.

### 4-4. EXPLANATION TO THE USER

- Using the OPERATING INSTRUCTIONS, explain to the user how to use the air conditioner (how to use the remote controller, how to remove the air filters, how to remove or put the remote controller in the remote controller holder, how to clean, precautions for operation, etc.)
- Recommend the user to read the OPERATING INSTRUCTIONS carefully.







**MITSUBISHI ELECTRIC CORPORATION**  
HEAD OFFICE: TOKYO BLDG., 2-7-3, MARUNOUCHI, CHIYODA-KU, TOKYO  
100-8310, JAPAN

JG79A073H02