

Manufactured Home Direct Vent Energy Saver Gas Water Heater



Photo is of
M-I-MS30T6LX

The Manufactured Home Models feature:

- **Housing and Urban Development**—This water heater is designed in accordance with H.U.D. and is certified for installation in a manufactured home (mobile home) only and must be installed in an enclosure that will completely separate the water heater combustion and venting system from the dwelling interior.
- **Sealed Combustion Roof Jack Kit**—Ordered separately and includes an adjustable air intake tube, roof jack and hardware. Must specify roof jack size when ordering. Available in 12", 18"/32", 32"/60" or 48"/95" lengths.
- **Flue Baffle**—Designed to maximize the amount of heat absorbed in the lower portion of tank. Minimizes air movement in the heater during standby periods to decrease heat loss up the flue.
- **Heat Traps**—Installed on hot water outlet to minimize heat loss through piping.
- **Vitraglas[®] Lining**—Bradford White tanks are lined with a exclusively engineered enamel formula that provides superior protection from the highly corrosive effects of hot water. This formula (Vitraglas[®]) is fused to the steel surface by firing at a temperature of over 1600°F.
- **Fully Automatic Controls**—Fast acting surface-mount thermostats for automatic temperature control. Factory installed sensitive manual reset energy cutoff for safety to prevent overheating.
- **1" Non-CFC Foam Insulation**—Covers the sides and top of tank, reducing the amount of heat loss. This results in less energy consumption, improved operation efficiencies and jacket rigidity.
- **Water Connections**—3/4" NPT factory installed true dielectric fittings extend water heater life and ease installation.
- **Protective Magnesium Anode Rod**—Provides added protection against corrosion for long trouble-free service.
- **T&P Relief Valve**—Installed.
- **Low Restriction Brass Drain Valve**—Durable tamper proof design.
- **Convertible Gas Control**—Easily convertible control for use with either Propane or Natural Gas.



6 or 10-Year Limited Tank Warranties / 6 or 10-Year Limited Warranty on Component Parts.

For more information on warranty, please visit www.bradfordwhite.com

For products installed in USA, Canada and Puerto Rico. Some states do not allow limitations on warranties. See complete copy of the warranty included with the heater.

Residential Direct Vent Gas Water Heater

Manufactured Home Energy Saver Models

NATURAL GAS AND LIQUID PROPANE GAS

Meet or exceed ASHRAE 90.1b (current standard) C.E.C. Listed
76% Recovery Efficiency

Model Number	Capacity		Recovery* 90°F Rise				A Floor to Top of Heater	B Jacket Dia.	C Vent Size	D Floor to T&P Conn.	E Floor to Gas Conn.	F Floor to Cold Water Conn.	G Floor to Hot Water Conn.	Approx. Shipping Weight		
	U.S. Gal.	Imp. Gal.	Nat. BTU/Hr. Input	LP BTU/Hr. Input	Nat. U.S. GPH	Nat. Imp. GPH									LP U.S. GPH	LP Imp. GPH
M-I-MS30T6LX	30	26	30,000	30,000	31	26	31	26	57 ⁷ / ₈	16	3	50	13 ³ / ₄	22 ¹ / ₂	58 ³ / ₈	106
M-I-MS40T6LX	40	33	30,000	30,000	31	26	31	26	57 ⁷ / ₈	18	3	50	13 ³ / ₄	22 ¹ / ₂	58 ⁷ / ₈	126

Model Number	Capacity		Recovery* 50°C Rise		A Floor to Top of Heater	B Jacket Dia.	C Vent Size	D Floor to T&P Conn.	E Floor to Gas Conn.	F Floor to Cold Water Conn.	G Floor to Hot Water Conn.	Approx. Shipping Weight	
	U.S. Gal.	Imp. Gal.	Nat. BTU/Hr. Input	LP BTU/Hr. Input									Nat. Liters/ Hour
M-I-MS30T6LX	114	8.8	8.8	117	-	1457	406	76	1270	349	572	1483	48
M-I-MS40T6LX	151	8.8	8.8	117	-	1470	457	76	1270	349	572	1485	55

To order Natural Gas heaters change "X" to "N".

For 10 year models, change suffix from "6" to "10".

* Based on manufacturers rated recovery efficiency.

Optional Roof Jack Kits			
Part Number	A	B	Through The Roof Clearance
239-37022-01	15"	16"-33"	12"
239-37022-02	33 ¹ / ₂ "	33 ¹ / ₂ "-66"	18" / 32"
239-37022-03	32 ¹ / ₂ "-62 ¹ / ₂ "	37 ¹ / ₂ "-74"	32" / 60"
239-37022-04	50"-98 ¹ / ₂ "	54 ¹ / ₂ "-109 ¹ / ₂ "	48" / 90"

(Includes: roof jack, hardware, air intake, instructions).

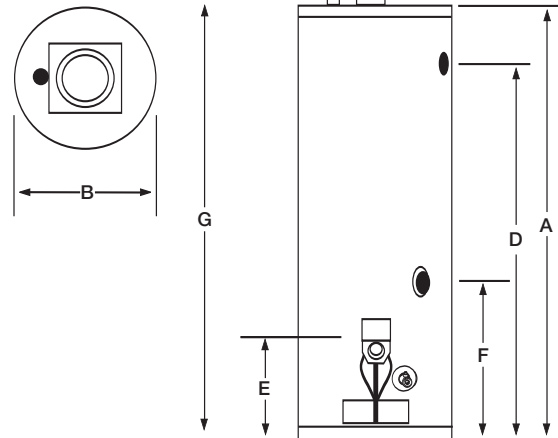
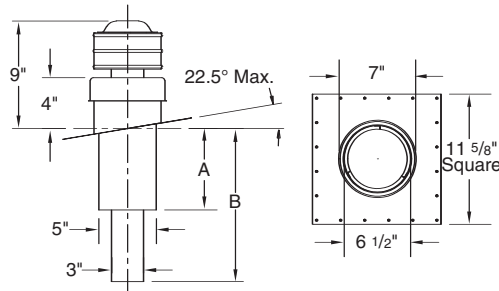

This water heater is of the closed combustion type (direct venting) for mobile home applications only, where all combustion air is supplied from the outdoors through the air intake and all combusted gas products are vented directly to the outside by means of the roof jack. No draft diverter (vent hood) is required for this water heater. The U.L. listing of this water heater includes the field installation of the following components: roof jack, roof jack clamp, air intake, air intake seal and heater tie down materials. These components for field installation are shipped with the heater in a separate box and must be installed according to instructions. No other components are approved for use with the water heater. The water heater must be installed in accordance with The Federal Mobile Home Construction and Safety Standard or in the absence of such standard, The Standard for Mobile Homes (ANSI/NFPA No. 601B-1977)

General

All gas water heaters are certified at 300 PSI (2068 kPa) test pressure and 150 PSI (1034 kPa) working pressure.

All water connections are 3/4" NPT (19mm), all gas connections are 1/2" (13mm).

All models design certified by CSA International (formerly AGA/CGA), ANSI Z-21.10.1 and peak performance rated.

Designed in accordance with the H.U.D. Manufactured Home Construction and Safety Standard, Title 24 CFR, Part 3280.707 (d)(2) for energy efficiency.

Dimensions and specifications subject to change without notice in accordance with our policy of continuous product improvement.

Suitable for Water (Potable) Heating and Space Heating.

Toxic chemicals, such as those used for boiler treatment, shall NEVER be introduced into this system. This unit may NEVER be connected to any existing heating system or component(s) previously used with a non-potable water heating appliance.



Ambler, PA

For U.S. and Canada field service, contact your professional installer or local Bradford White sales representative.

Sales 800-523-2931 • Fax 215-641-1670 / Technical Support 800-334-3393 • Fax 269-795-1089 • Warranty 800-531-2111 • Fax 269-795-1089

International: Telephone 215-641-9400 • Telefax 215-641-9750 / www.bradfordwhite.com



BRADFORD WHITE-CANADA INC. Sales / Technical Support 866-690-0961 / 905-238-0100 • Fax 905-238-0105 / www.bradfordwhite.com

Built to be the Best™

©2010, Bradford White Corporation. All rights reserved.