

DuPont™ Suva® refrigerants

ART-6

Guidelines for Converting Nonaqueous Refrigeration Brine Systems to Use DuPont™ Suva® 123

Applications

In many industrial refrigeration applications the refrigeration equipment is located in a service facility separate from the industrial process. The process heat is transferred to the refrigeration equipment by means of a circulating heat transfer fluid known as a “brine” or secondary refrigerant. The most commonly used brines are water-based solutions of salts, glycols, or alcohols. However, for low temperatures or in situations where chemical inertness is important, chlorinated organic solvents (methylene chloride, trichloroethylene) or CFCs (CFC-11, CFC-113) have been widely and successfully used. These compounds are no longer acceptable from an environmental or, in the case of the chlorinated solvents, an occupational health standpoint. HCFC-123 (DuPont™ Suva® 123) is a viable replacement for these solvents as a heat-transfer fluid.

Users must read and understand the HCFC-123 Material Safety Data Sheet (MSDS). Copies of the MSDS are available by contacting DuPont at any of the locations shown on the last page of this bulletin. Refer also to DuPont Bulletin P-123, “HCFC-123 Properties, Uses, Storage, and Handling” and Bulletin AS-5, “Workplace Guidelines for HCFC-123 in Refrigeration and Air Conditioning Applications.”

Industrial brine systems have two significant differences from refrigeration systems:

1. System size. The transfer of heat is achieved by means of sensible heat, the heating and cooling of a circulating fluid mass (in effect forced convection). Very often the process heat sources served by a brine system are multiple (different process operations) and distant from the refrigeration building, requiring long runs of pipe.

Figure 1. Brine System Process Scheme

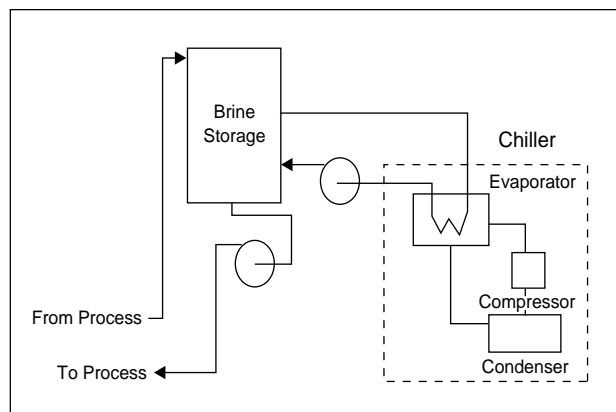

A typical brine system schematic is shown in **Figure 1**.

Brine systems typically operate with large volumes of brine—10,000 gal (40 m³) or larger systems are common, with high circulating flow rates.

2. Temperature/phase change. Brine systems operate normally over a relatively narrow temperature range, in the liquid phase only. Pressure variations in the system are due to hydrodynamic pressures only.

Factors discussed above imply that brine system leaks will be in the liquid phase. These may well occur at inaccessible locations. As the chlorinated solvents, CFCs, and HCFC-123 are all volatile liquids, large losses may occur before leaks are detected unless special controls and precautions are observed (see Operational Aspects).



The miracles of science™

General Guidelines

Brine System Installation

- The brine system should be in an industrial facility. We do not recommend the use of HCFC-123 brine systems in residential or commercial installations.
- The system should be designed to permit isolation and drainage of individual components/equipment items such as pumps, strainers, heat exchangers, etc., for maintenance, without spillage loss of the brine.
- The brine storage tank should be fitted with a nitrogen blanket (to prevent entry of moisture into the system during changes in dead space volume, such as during start-up situations) and a conservation vent set at 10 psig. The brine storage tank should be rated to withstand full vacuum.
- Brine pumps should be equipped with mechanical seals (not packed gland type shaft seals).
- Any enclosed working area (accessed by operating/maintenance personnel) that contains brine handling equipment should be equipped with a compound-specific (HCFC-123) monitor (see below) and should be equipped with adequate forced or natural ventilation. These recommendations are specified in ASHRAE Standard 15. The term “enclosed working areas” includes refrigeration buildings, pump houses, and pump pits. It is important to bear in mind that HCFC-123 vapors are heavier than air and will tend to accumulate in low-lying areas.

Retrofit Considerations

Design Guidelines

When planning a retrofit of a brine system to HCFC-123 it is important to check heat transfer design calculations for the system. Rates will be very similar if the retrofit is being made from CFC-11 or CFC-113. However, HCFC-123 has a specific heat approximately 15% lower than methylene chloride, requiring higher circulating flow rates and increased pumping power.

Materials Compatibility

It is important to verify the compatibility of brine wetted system components with HCFC-123 in order to minimize the risk of system leaks and component failure. There are no significant compatibility differences between HCFC-123 and other chlorinated solvents or CFCs with respect to metals.

The following polymeric materials are not recommended for critical service use in contact with liquid HCFC-123:

Elastomers	Plastics
Natural Rubber	Polymethylmethacrylate
Polyurethane Rubber	Polycarbonate
Silicone Rubbers	Polystyrene
Nitrile Rubber	ABS Copolymers
NSR Rubbers	Ethyl Cellulose Polymers

In many applications HCFC-123 has shown negligible adverse effect on the following materials:

Elastomers	Plastics
Neoprene W	Zytel® (Nylon)
Viton®	Teflon®
Nordel®	Polyethylene
Butyl Rubber	Polypropylene

Note that commercial compounded formulations of these vary and we recommend that the individual manufacturer of each component be contacted to determine whether their specific product has been tested with HCFC-123.

For severe mechanical service with HCFC-123, DuPont has developed a special grade of Kalrez® perfluoroelastomer.

Table 1
Brine Property Comparisons

	Aqueous Calcium Chloride (25%)	Methylene Chloride	CFC-11	CFC-113	HCFC-123
Boiling Point					
°C	>100	40	24	48	28
°F	>212	104	75	118	82
Freezing Point					
°C	-29	-97	-111	-35	-107
°F	-20	-143	-168	-31	-161
Vapor Pressure (at 25°C)					
kPa	NA	57	106	45	91
psig	NA	-6.4	0.7	-8.2	-1.5
Viscosity					
mPa·s	12	0.70	0.73	1.49	0.82
cP	12	0.70	0.73	1.49	0.82
Specific Heat					
kJ/kg·K	2.81	1.13	0.84	0.88	0.90
Btu/lb·°F	0.67	0.26	0.20	0.21	0.22
Thermal Conductivity					
W/m K	0.50	0.19	0.10	0.08	0.096
Btu/hr ft °F	0.29	0.11	0.06	0.05	0.056
Density					
kg/m ³	1260	1400	1560	1650	1578
lb/ft ³	78.8	87.5	97.5	103.0	98.5

Note: Properties other than vapor pressure are given at -24°C (-11°F).

NA = Not Available

System Preparation for Retrofit

After removal of the previous brine and change out of any mechanical components in the system, it is important that a thorough leak check be made of the entire system. The system should be dried thoroughly (preferably by blowing through with nitrogen) before being charged with HCFC-123 for the first time.

Monitoring Confined Spaces

DuPont has concluded that HCFC-123 poses no acute or chronic hazard when it is handled in accordance with recommendations and when exposures are maintained at or below the DuPont acceptable exposure limit (AEL) of 50 ppm.

An AEL is an airborne exposure limit established by DuPont that specifies the time-weighted average (TWA) for airborne concentrations to which nearly all workers may be repeatedly exposed without adverse effects during an 8- or 12-hr workday or 40-hr workweek.

DuPont has also set an emergency exposure limit (EEL) of 1,000 ppm for up to 1 hr with a 1-min ceiling of 2,500 ppm based on the acute or short-term effects of HCFC-123. During an emergency, occurring rarely in a lifetime, workers may be exposed to these concentrations without harmful effects. The short-term (or acute) effects of CFC-11 and HCFC-123 are similar, and any necessary response to emergency situations involving either would be essentially the same.

It is important that any confined spaces that have HCFC-123-containing equipment be monitored on a continuous basis to insure that employees are not exposed to levels of HCFC-123 above that compound's AEL. Installation of monitoring instrumentation is a requirement of ASHRAE Standard 15. We strongly recommend that a compound-specific monitor with a range of 0–150 ppm HCFC-123 be used.

The monitor should have the capability of giving a continuous readout of the atmospheric concentration level of HCFC-123 and should have a two-level alarm capability:

- The first alarm level should be set at 50 ppm to give warning of a situation requiring investigation and corrective measures.
- The second alarm level should be set at 150 ppm and should give a clearly recognizable signal to both the operating personnel responsible for the area, and also to others who might be planning to

enter the monitored area. The alarm signal can also be used to initiate specific corrective actions (such as the automatic starting of auxiliary ventilation devices). No one should enter, or remain in, the monitored area without using proper respiratory protection until the measured level of HCFC-123 falls below 50 ppm.

Operational Aspects

Safety

It is of the highest importance that the people directly involved with the operation and maintenance of the brine system fully understand the safety aspects of HCFC-123 as expressed in the MSDS and DuPont bulletins listed in Additional Information. These people should have available to them at all times, and be fully conversant with the use of, proper personal protective equipment. Specifically, it is important that respiratory protective equipment be available. Individual cartridge (organic vapor) breathing masks should be provided for use during high vapor level situations; and breathing-air supplied masks should be available for certain maintenance situations and entering confined spaces having high vapor concentrations of HCFC-123.

Refer to Bulletin AS-5 for DuPont recommendations on minimum respirator protection.

Loss/Spill Control

It is important from an environmental and an economic point of view that losses from the brine system be held at an absolute minimum. It is recommended that maintenance procedures be implemented which emphasize the containment and recovery of brine drained from the system during maintenance. Routine inspection for leaks should be programmed, and an inventory control program will help detect and manage uncontrolled losses of brine.

Additional Information

1. DuPont MSDS for HCFC-123 Refrigerant.
2. DuPont Bulletin P-123, "HCFC-123 Properties, Uses, Storage, and Handling."
3. DuPont Bulletin AS-5, "Workplace Guidelines for HCFC-123 in Refrigeration and Air Conditioning Applications."
4. DuPont Bulletin ARTD-27, "Leak Detectors for Use with Alternative Refrigerants."

For Further Information:

DuPont Fluorochemicals
Wilmington, DE 19880-0711
(800) 235-SUVA
www.suva.dupont.com

Europe

DuPont de Nemours
International S.A.
2 Chemin du Pavillon
P.O. Box 50
CH-1218 Le Grand-Saconnex
Geneva, Switzerland
41-22-717-5111

Canada

DuPont Canada, Inc.
P.O. Box 2200, Streetsville
Mississauga, Ontario
Canada
L5M 2H3
(905) 821-3300

Mexico

DuPont, S.A. de C.V.
Homero 206
Col. Chapultepec Morales
C.P. 11570 Mexico, D.F.
52-5-722-1100

South America

DuPont do Brasil S.A.
Alameda Itapecuru, 506
Alphaville 06454-080 Barueri
São Paulo, Brazil
55-11-7266-8263

DuPont Argentina S.A.
Casilla Correo 1888
Correo Central
1000 Buenos Aires, Argentina
54-1-311-8167

Pacific

DuPont Australia
P.O. Box 930
North Sydney, NSW 2060
Australia
61-2-99236111

Japan

Mitsui DuPont Fluorochemicals
Co., Ltd.
Chiyoda Honsha Bldg.
5-18, 1-Chome Sarugakucho
Chiyoda-Ku, Tokyo 101-0064 Japan
81-3-5281-5805

Asia

DuPont Taiwan
P.O. Box 81-777
Taipei, Taiwan
886-2-514-4400

DuPont China Limited
P.O. Box TST 98851
1122 New World Office Bldg.
(East Wing)
Tsim Sha Tsui
Kowloon, Hong Kong
Phone: 852-734-5398
Fax: 852-236-83516

DuPont Thailand Ltd.
9-11 Floor, Yada Bldg.
56 Silom Road
Suriyawongse, Bankrak
Bangkok 10500
Phone: 66-2-238-0026
Fax: 66-2-238-4396

DuPont China Ltd.
Rm. 1704, Union Bldg.
100 Yenan Rd. East
Shanghai, PR China 200 002
Phone: 86-21-328-3738
Telex: 33448 DCLSH CN
Fax: 86-21-320-2304

DuPont Far East Inc.
6th Floor Bangunan Samudra
No. 1 JLN. Kontraktor U1/14, SEK U1
Hicom-Glenmarie Industrial Park
40150 Shah Alam, Selangor Malaysia
Phone 60-3-517-2534

DuPont Korea Inc.
4/5th Floor, Asia Tower
#726, Yeoksam-dong, Kangnam-ku
Seoul, 135-082, Korea
82-2-721-5114

DuPont Singapore Pte. Ltd.
1 Maritime Square #07 01
World Trade Centre
Singapore 0409
65-273-2244

DuPont Far East, Philippines
8th Floor, Solid Bank Bldg.
777 Paseo de Roxas
Makati, Metro Manila
Philippines
Phone: 63-2-818-9911
Fax: 63-2-818-9659

DuPont Far East Inc.
7A Murray's Gate Road
Alwarpet
Madras, 600 018, India
91-44-454-029

DuPont Far East Inc.—Pakistan
9 Khayaban-E-Shaheen
Defence Phase 5
Karachi, Pakistan
92-21-533-350

DuPont Far East Inc.
P.O. Box 2553/Jkt
Jakarta 10001, Indonesia
62-21-517-800

The information contained herein is based on technical data and tests which we believe to be reliable and is intended for use by persons having technical skill, at their own discretion and risk. Because conditions of use are outside of DuPont control, we can assume no liability for results obtained or damages incurred through the application of the data presented.

© 2004. E. I. du PONT de NEMOURS AND COMPANY. ALL RIGHTS RESERVED.

NO PART OF THIS MATERIAL MAY BE REPRODUCED, STORED IN A RETRIEVAL SYSTEM OR TRANSMITTED IN ANY FORM OR BY ANY MEANS ELECTRONIC, MECHANICAL, PHOTOCOPYING, RECORDING, OR OTHERWISE WITHOUT THE PRIOR WRITTEN PERMISSION OF DUPONT.



The miracles of science™