

## Fireplace Heater Freestanding Models

Rinnai model number:	Natural Gas	Propane
	RFBV- FS35ETR-BN (Black)	RFBV- FS35ETR-BP (Black)
	RFBV- FS35ETR-SN (Silver)	RFBV- FS35ETR-SP (Silver)
Description:	Freestanding radiant/convector, glass-fronted, ceramic log space heater with forced convection and natural draft flue system.	
Gas Rate (Input):	Natural Gas	Propane
	Btu/hr	Btu/hr
	Low:	11,000
	Med (Lo):	19,000
	Med (Hi):	24,000
	High:	32,000
Gas Rate (Output):	24,000	22,000
Efficiency Rating:	75%	76%
Gas Supply Pressure:	WC	WC
	Min:	7"
	Max:	10.5"
Gas Connection:	3/8" FNPT	
Gas Control:	Electronic control valve	
Heat transfer:	Direct radiation and forced convection	
Installation Type:	Freestanding	
Weight:	1411b	
Glass Viewing Area:	11-1/2"H x 23-1/4"W	
Dimensions:		

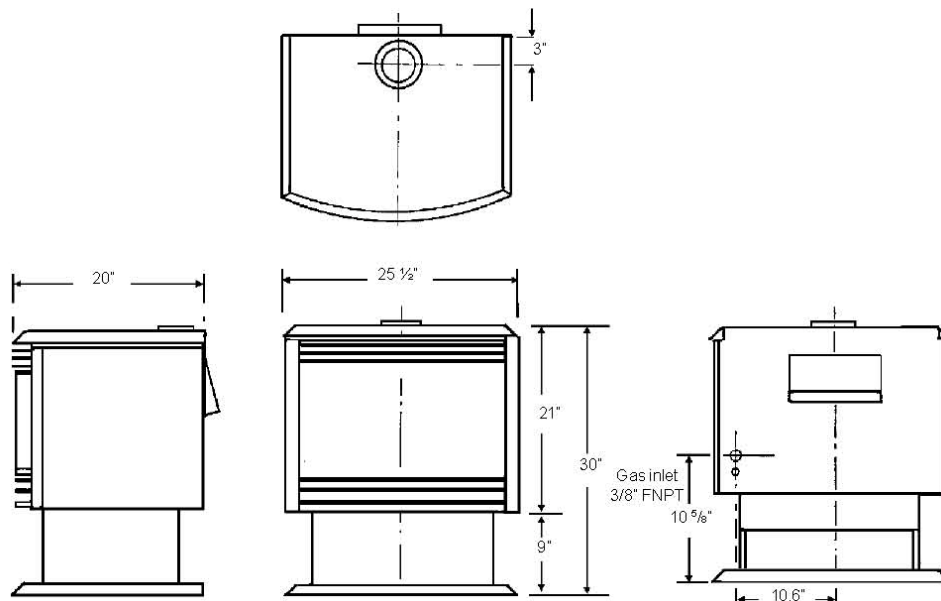

# FS35-ETR

Flue Type:	Approved 4" B vent system
Flue Termination:	An approved 4" vent cap must be fitted to all installations.
Fan:	90 Watt 2 speed tangential
Fan Delay:	Micro computer timer
Combustion System:	Multi port burner and ceramic logs
Logs:	Realistic 5 piece ceramic log set
Burner:	Ember bed flame and heat burner
Warm Air Discharge:	Top front louvers
Ignition System:	Continuous spark electronic ignition
Power Supply:	115 Volts 60Hz AC
Safety Devices:	Flame failure – flame rod Over heat – thermistors, thermal fuse 239°F Power surge – 3 amp fuse Room overheat – Automatic cut off at 104°F after 10 minutes
Combustion Method:	Naturally aspirated burner
Flue Requirement:	Manufacturers minimum, 10 ft. vertical (Local coded may require a greater Length and must be followed.)

Temperature control: Electronic thermostat High~Low / Off  
Flame picture selection option (thermostat override)  
Up / Down buttons

Temperature range: Low = 50°F, 60°F~80°F, High 97°F

Operation: Finger touch control buttons or remote control

Control panel / Remote control:

