

Fireplace Heater Freestanding Manual Operation Model

Rinnai model number:	Natural Gas RFBV- FS35M-BN (Black)	Propane RFBV- FS35M-BP (Black)
Description:	Freestanding radiant/convector, glass-fronted, ceramic log space heater with forced convection and natural draft flue system.	
Gas Rate (Input):	Natural Gas Btu/hr	Propane Btu/hr
	Low: 13,000	11,000
	High: 34,000	31,000
Gas Rate (Output):	26,000	23,000
Efficiency Rating:	76%	74%
Gas Supply Pressure:	WC	WC
	Min: 7"	10"
	Max: 10.5"	13"
Gas Connection:	3/8" FNPT	
Gas Control:	Push button combination control valve	
Heat transfer:	Direct radiation and forced convection	
Installation Type:	Freestanding	
Weight:	141lb	
Glass Viewing Area:	11-1/2"H x 23-1/4"W	
Dimensions:		

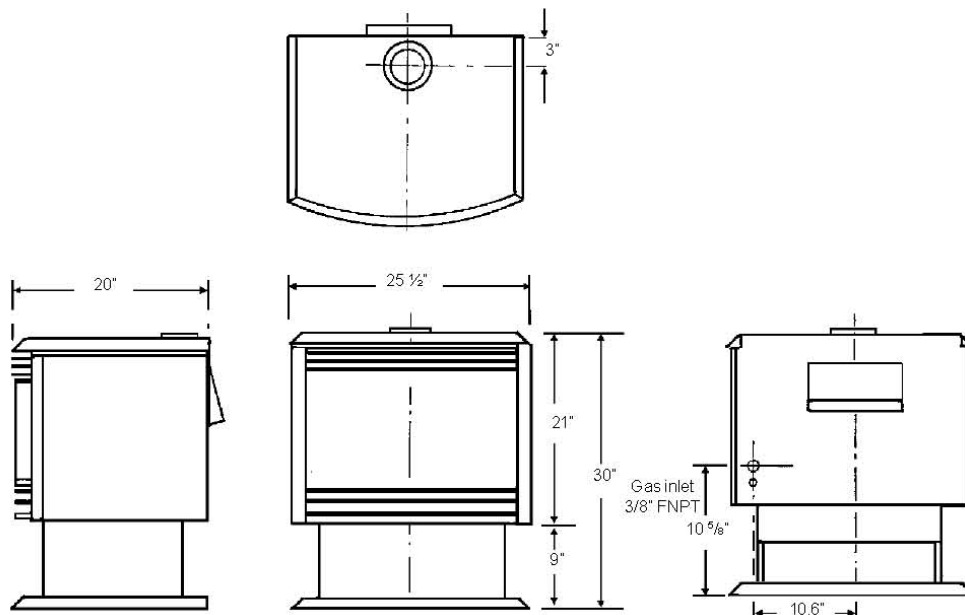

Flue Type:	Approved 4" B vent system
Flue Termination:	An approved 4" vent cap must be fitted to all installations.
Fan:	90 Watt 2 speed tangential
Combustion System:	Multi port burner and ceramic logs
Logs:	Realistic 5 piece ceramic log set
Burner:	Ember bed flame and heat burner
Warm Air Discharge:	Top front louvers
Ignition System:	Continuous spark electronic ignition
Power Supply:	115 Volts 60Hz AC
Safety Devices:	Flame failure thermocouple Over heat Bi-metal strip 239°F Fan delay Bi-metal strip
Combustion Method:	Naturally aspirated burner
Flue Requirement:	Manufacturers minimum, 10 ft. vertical (Local coded may require a greater length and must be followed.)
Operation:	Push button to light pilot and main burners
Control panel:	

