



VICTORY™ II

HOT WATER MODELS VHS-30 THROUGH VHS-180 GAS-FIRED CAST-IRON BOILERS FOR NATURAL AND L.P. PROPANE GASES



This manual must be left with owner and should be hung on or adjacent to the boiler for reference.

Models with Intermittent Pilot System – Spark Ignition INSTALLATION AND OPERATING INSTRUCTIONS

Contents	Page
Dimensions, Rating and Orifice Sizes	2
Installation Requirements:	
Boiler Location and Foundation	3
Minimum Clearances	3
Boiler Room Air Supply and Ventilation	4
Flue Gas Venting Requirements	4
Category II and III Venting:	
Venting Material	5
Flue Length Restriction	5
Installation	5
Category I Venting:	
Installation	10
Vent Connector Material	10
Venting Requirements	10
Venting System Regular Inspection	14
Gas Piping	14
Electrical Wiring	14
Boiler Water Temperature Control	19-23
Water Piping	26
Piping a Heating-Cooling System	26
Operating Instructions:	
Filling and Venting Water Systems	27
Initial Start	27
Safety Information	27
Operating Instruction	27
Burner Adjustment	27
Safety Check	28
Care and Maintenance	29
Sequence of Operations	31
General Troubleshooting Guide	32
Appendix A and B	34

IMPORTANT

READ ALL OF THE FOLLOWING WARNINGS AND STATEMENTS BEFORE READING THE INSTALLATION INSTRUCTIONS

WARNING
SEE "WARNING" ON PAGE 3 FOR LIQUEFIED PETROLEUM (L.P.) PROPANE GAS-FIRED BOILERS

The installation must conform to the requirements of the authority having jurisdiction or, in the absence of such requirements, to the National Fuel Gas Code, ANSI Z223.1-latest edition. The installation must also conform to the additional requirements in this Slant/Fin Instruction Book.

In addition where required by the authority having jurisdiction, the installation must conform to American Society of Mechanical Engineers Safety Code for Controls and Safety Devices for Automatically Fired Boilers, No. CSD-1.

WARNING
This boiler, gas piping and accessories must be installed, connected, serviced and repaired by a trained, experienced service technician, familiar with all precautions required for gas-fired equipment and licensed or otherwise qualified, in compliance with the authority having jurisdiction.

WARNING
The venting system of this boiler is under positive pressure when it is connected to the outdoors with 3" diameter pipe. Leakage from this system can be hazardous and if not avoided can result in death or serious injury. In addition to the recommendations within this manual and the User's Information Manual, the venting system, from the blower to the outdoor discharge, must be carefully checked annually by a qualified service agency.

Heating Contractor

Address

Phone Number

Boiler Model Number

Boiler Serial Number

Installation Date

Figure 1. Views - Dimensions - Data

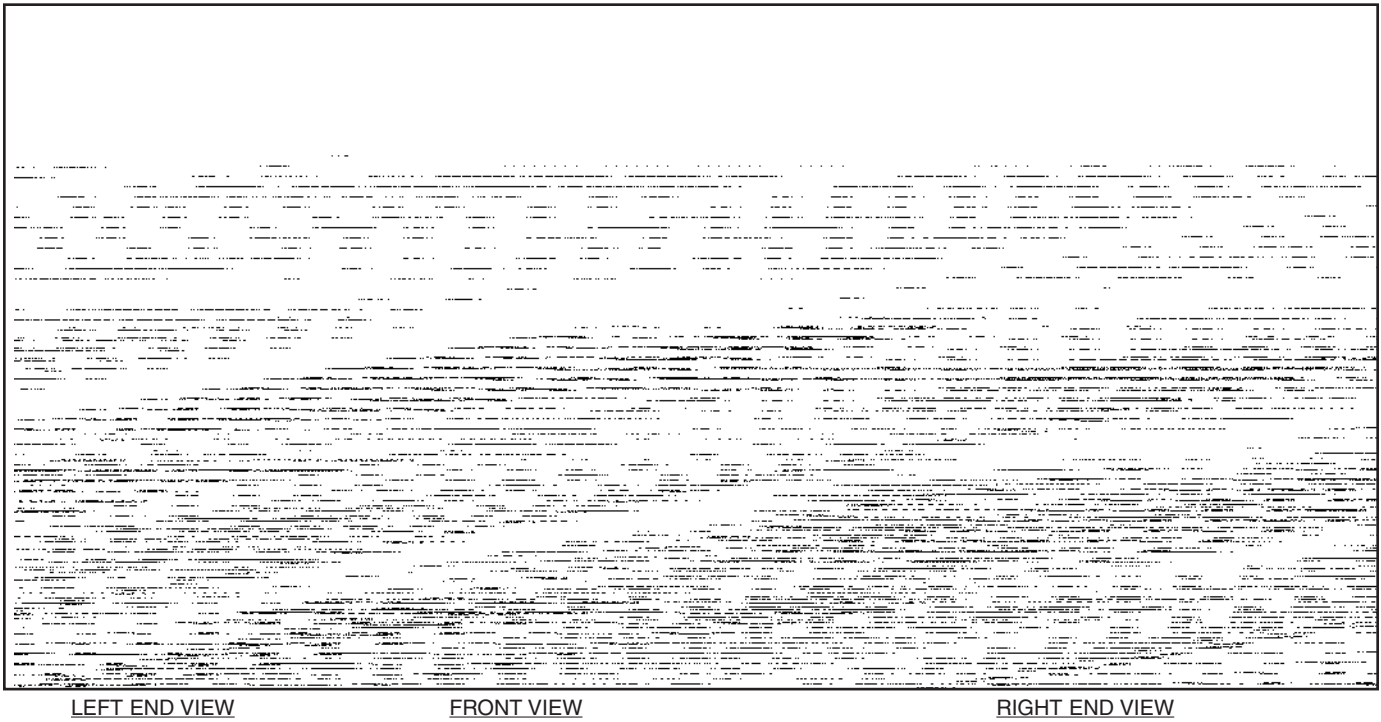

NOTE: Height dimensions increase by 1¼" and depth increases to 22¼" when combustible floor kit is used.

Boiler Model	Input Btuh	No. of Sections	A	B	Approx. Total Wt. Full of Water (lb.)
VHS-30EP	30,000	2	8½"	14½"	190
VHS-60EP	60,000	3	11½"	17½"	250
VHS-90EP	90,000	4	14½"	20½"	310
VHS-120EP	120,000	5	17½"	23½"	365
VHS-150EP	150,000	6	20½"	26½"	425
VHS-180EP	180,000	7	23½"	29½"	485

Figure 2. Base Assembly Victory II - VHS Boiler

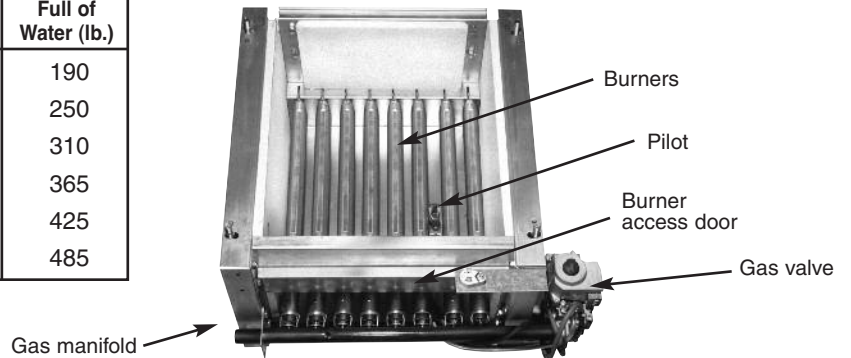

Gas Type	Orifice Size for Sea Level	Orifice Sizes for High Altitudes Includes 4% Reduction for Each 1000 Feet								
		Elevation — Feet								
		2000	3000	4000	5000	6000	7000	8000	9000	10000
Natural	#49	50	50	50	51	51	51	52	52	52
Propane	#57	58	59	59	60	60	61	62	63	63

Orifice sizes indicated for sea level above are factory installed in boiler unless otherwise specified by the local authority. Orifice table is based on a higher heating value between 1000 Btuh and 1010 Btuh for Natural Gas (See page 21, if local higher heating value exceeds these numbers). See page 21, for burner input adjustment.

INSTALLATION REQUIREMENTS

The installation must conform to the requirements of the authority having jurisdiction or, in the absence of such requirements, to the National Fuel Gas Code, ANSI Z223.1-latest edition.

This installation must also conform to the additional requirements in this Slant/Fin Instruction Book.

NATURAL GAS-FIRED BOILER LOCATION

Provide a level, solid foundation for the boiler. Location should be as near as possible to chimney or outside wall so that the flue pipe from boiler is short and direct. (See Appendix A for vent terminal location restrictions.) The location should also be such that the gas ignition system components are protected from water (dripping, spraying, rain, etc.) during appliance operation and service (circulator replacement, condensate trap, control replacement, etc.).

WARNING

SPECIAL ATTENTION FOR LIQUEFIED PETROLEUM (L.P.) PROPANE GAS-FIRED BOILER INSTALLATIONS

LPG appliances (boilers) shall be installed in accordance with applicable provisions of NFPA 58 (Liquefied Petroleum Gas Code) latest edition for installations in US and CAN/CGA B149.1 latest edition for installations in Canada.

Liquefied Petroleum (LP) propane gas is heavier than air therefore Propane gas accumulate at floor level. If you suspect a leak, do not attempt to operate boiler. A spark or flame from the appliance (boiler) or other sources may ignite the accumulated propane gas causing an explosion or fire. It is recommended that inspections for gas leaks be performed periodically by licensed professional and that leak detection devices be installed as a further safety measure.

BOILER FOUNDATION

- A. Provide a solid, level foundation, capable of supporting the weight of the boiler filled with water, and extending at least 2" past the jacket on all sides. See dimensions of boilers, page 2.
- B. For installation on non-combustible floors only*.
- C. If boiler is to be located over buried conduit containing electric wires or telephone cables, consult local codes or the National Board of Fire Underwriters for specific requirements.

* Installation on combustible flooring allowed only with proper Combustible Floor Kit. Kit part number is printed on boiler rating plate. In no case may the boiler be installed on carpeting.

MINIMUM CLEARANCES FROM COMBUSTIBLE CONSTRUCTIONS

- A. Minimum clearances to the exterior surfaces of the boiler shall be as follows:

MINIMUM ALCOVE AND CLOSET CLEARANCE

<u>Surface</u>	<u>For Combustible Construction</u>	<u>Recommended for Service</u>
Front	6"	18"
Rear	6"	18"
Left Side	6"	18"
Right Side	12"	24"
Top	12"	12"
Flue Connector:		
Enclosed —	6"	6"
Unenclosed —	2"	6"

- B. Provide accessibility clearance of 24" on sides requiring servicing and 18" on sides used for passage.
- C. All minimum clearances shown above must be met. This may result in increased values of some minimum clearances in order to maintain the minimum clearances of others.
- D. Clearance from hot water pipes shall be 1 inch**.

** At points where hot water pipes emerge from a floor, wall or ceiling, the clearance at the opening through the finished floor boards or wall or ceiling boards may be not less than 1/2 inch. Each such opening shall be covered with a plate of uncombustible material.

SAFETY

KEEP THE BOILER AREA CLEAR AND FREE FROM COMBUSTIBLE MATERIALS, GASOLINE AND OTHER FLAMMABLE VAPORS AND LIQUIDS.



Figure 3.

BOILER ROOM AIR SUPPLY AND VENTILATION

An ample supply of air is required for combustion and ventilation. When buildings are insulated, caulked and weatherstripped, now or later on, direct openings to outside may be required and should be provided. If the boiler is not near an outside wall, air may be ducted to it from outside wall openings.

Provisions for combustion and ventilation air must be made in accordance with section 5.3, Air for Combustion and Ventilation, of the National Fuel Gas Code, ANSI Z223.1-latest edition, or applicable provisions of the local building codes. The following recommendation applies to buildings of energy-saving construction, fully caulked and weatherstripped.

INSTALLATION IN ENCLOSED BOILER ROOM REQUIRES TWO UNOBSTRUCTED OPENINGS FOR PASSAGE OF AIR INTO THE BOILER ROOM:

1. **Air drawn horizontally from outdoors DIRECTLY through an outside wall;** one louvered opening near the floor and one louvered opening near the ceiling, each opening with a minimum FREE air passage area of **1 square inch per 4000 Btuh** of total appliances' input.
2. **Air drawn horizontally through HORIZONTAL DUCTS;** one opening near the floor and one opening near the ceiling, each opening with a minimum FREE air passage area of **1 square inch per 2000 Btuh** of total appliances' input.
3. **Air drawn VERTICALLY from outdoors;** one opening at the floor and one opening at the ceiling, each opening with a minimum FREE air passage area of **1 square inch per 4000 Btuh** of total appliances' input.
4. **Air drawn from inside the building;** one opening near the floor and one opening near the ceiling, each opening with a minimum FREE air passage area of **1 square inch per 1000 Btuh** of total appliances' input.

IF BOILERS ARE INSTALLED ADJACENT TO OTHER FUEL BURNING EQUIPMENT, THE AREA OF FREE OPENINGS MUST BE APPROPRIATELY INCREASED TO ACCOMMODATE THE ADDITIONAL LOAD.

Openings must never be reduced or closed. If doors or windows are used for air supply, they must be locked open. Protect against closure of openings by snow and debris. Inspect frequently.

No mechanical draft exhaust or supply fans are to be used in or near the boiler area.

The flow of combustion and ventilating air to the boiler must not be obstructed.

FLUE GAS VENTING REQUIREMENTS

The Victory II series boiler is a high efficiency, mechanically induced draft boiler and, therefore, requires different venting arrangements than natural draft, lower efficiency boilers.

THE FOLLOWING INSTRUCTIONS MUST BE CAREFULLY READ AND FOLLOWED IN ORDER TO AVOID ANY HAZARDOUS CONDITIONS DUE TO IMPROPER INSTALLATION OF THE FLUE GAS VENTING SYSTEM.

The vent piping installation MUST be in accordance with these instructions and with ANSI Z223.1-latest edition NATIONAL FUEL GAS CODE, Part 7, Venting of Equipment. Other local codes may also apply and must be followed. Where there is a conflict between these requirements, the more stringent case shall apply.

The use of a vent damper or similar devices is NOT permitted on this boiler series.

Approved Venting Applications

Victory II model VHS-90 through 180 are Category III and VHS-30 and 60 are Category II boilers, these boilers must be vented by proper 3" diameter venting system (see Category II and III venting - page 5).

Models VHS-90 through 180 are also Category I boilers when using a minimum of 5" diameter connector and vented into a natural draft chimney or Type "B" vent using a 3"x5" diameter vent adapter (see Category I venting - page 9).

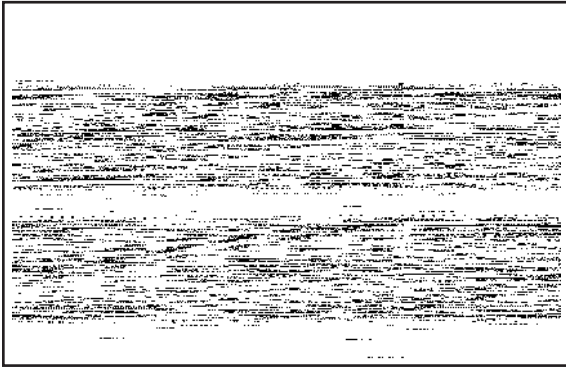

Figure 4. Vent Sealing Instructions
(Consult vent manufacturer's instructions.)

CATEGORY II AND III VENTING

1. Vent Material

A) The vent system for horizontal or vertical venting (Category II and III) must be UL listed single wall 3" diameter AL29-4C[▲] stainless steel material. The following manufacturers' systems are approved for use within a specified minimum and maximum equivalent vent length for each model. Proper adapter must be used as a connector between Victory II boilers flue collar and venting system as shown below:

Manufacturer	Type/System	Adapter Part No.	Sealant
Heat-Fab, Inc.	Saf-T Vent	Not Required	RTV 106 or DOW Coming 732
Heat-Fab, Inc.	Saf-T Vent EZ Seal	Not Required	Not Required
Pro-Tech System, Inc.	FasNSeal	FSA-HFA3	Not Required
Flex-L International, Inc	StaR-34	SRAFSA3	GE-1S806
Z-Flex, Inc.	Z-Vent	O2SVSSLA2	GE, RTV 106

Heat-Fab Part Numbers for various items of vent system are listed in Slant/Fin Part List, Publication No. VHS-10PL.

- B) When joining the various components of the above listed vent systems, the manufacturers' instructions should be closely followed to insure proper sealing.
- C) Use sealant specified by vent system manufacturer for sealing of pipe and fittings. See Figure 4 for proper application of vent pipe sealing for Safe-T vent system by Heat-Fab, Inc.
- D) All vent connections must be liquid and pressure tight
- E) Flue vent system CANNOT be cut to length. Consult manufacturer's instructions. For Heat-Fab system, use slip joint connector (Part No. 7324-GC) to adjust pipe lengths dimensions.
- F) DO NOT use plastic or galvanized flue pipe.

2. Flue Length Restriction

Maximum and minimum equivalent flue length for different systems are given in the tables on page 6. Equivalent flue length is sum of straight flue lengths and equivalent length of elbows. The vent termination is in addition to the allowed equivalent lengths.

Example: Boiler Model VHS-180 is to be installed at sea level with 2 elbows using Heat-Fab vent system. Maximum straight run would be: 40 - 2 x 3 = 34ft. If same boiler is to be installed in Colorado Springs (5,980 ft. altitude), the maximum straight run would be: 20 - 2 x 3 = 14 ft.

3. Installation

A. Horizontal Venting:

Figures 5 and 6 show typical horizontal venting. For combustible wall passage of vent piping a U.L. listed thimble must be used. See Figures 5 and 6 for wall thimble Part Numbers and more information.

CAUTION: Flue gasses exiting from the vent terminal will condense. Building materials in the area of the vent terminal should be protected from discoloration and degradation.

VENT TERMINATION LOCATION AND CLEARANCES

1. The venting system shall terminate at least 3 feet above any forced air inlet located within 10 feet.
2. The venting system shall terminate at least 12 inches below, or 12 inches horizontally from, any door, window or gravity air inlet into any building. The bottom of the vent terminal shall be at least 12 inches above grade or the normal snow level whichever is greater.
3. Through the wall vents shall not terminate over public walkways or over areas where condensate or vapor could create a nuisance or hazard or could be detrimental to the operation of regulators, relief valves or other equipment. Minimum clearance of 4 feet horizontal distance is maintained, from electric meters, gas meters, regulators and relief equipment.
4. Vent termination must not be located in any confined space (i.e. window wells, alcoves, narrow alleys) or under any overhang or deck. Vent termination should not allow flue gas discharge towards neighbor's windows or where personal injury or property damages can occur.

B. Vertical Venting:

Figure 7 shows typical vertical venting. A fire stop is required for each ceiling and floor penetration. An existing chimney (see Figure 8) may be used as a chase for vertical venting. Other appliances CANNOT be vented into the same chimney or vent pipe within the chimney.

For both, horizontal and vertical venting, the following points MUST be followed:

- A. All Victory II boilers are equipped with a built-in condensation drain and trap. The trap loop must be filled with water. DO NOT operate the boiler without filling the trap with water to prevent flue gas discharge into space. The drain should extend to a floor drain or to a container which may require emptying periodically.
- B. The horizontal vent pipe must be sloped upward from the boiler at a pitch of at least 1/4" per 1 foot of run, so that the condensate from the vent system runs to the drain trap.
- C. The horizontal vent pipes must be supported with pipe straps at intervals no greater than indicated by vent pipe manufacturer's instructions. The vertical portion vent pipe also must be supported per manufacturer's instructions.
- D. Minimum clearances of vent pipes from combustible constructions must be maintained (see Page 3).
- E. Common venting with other appliances or another Victory II boiler is NOT allowed.
- F. The vent piping must terminate with a screened elbow or tee. See Figures 5 and 6 for horizontal and 7 and 8 for vertical termination information. A cap termination may be used for vertical venting.
- G. See Appendix A for vent system location and condensation drain requirements.
- H. For roof passage of vent piping a U.L. listed roof flashing must be used.

▲: AL 29-4C is a registered trademark of Allegheny Ludlum Corp.

Heat-Fab Saf-T Vent System

Boiler Model No.	Max. Equivalent Length (Ft.)			Equivalent Length of each 90° Elbow, Ft.	Minimum Length, Ft.
	0 to 5500 Ft. Altitudes	5500 to 7000 Ft. Altitudes	7000 to 10,000 Ft. Altitudes		
VHS-30, 60, 90 and 120	40	40	40	3	2
VHS-150	40	40	20	3	2
VHS-180	40	20	20	3	2

ProTech FasNSeal System

Boiler Model No.	Max. Equivalent Length (Ft.)			Equivalent Length of each 90° Elbow, Ft.	Minimum Length, Ft.
	0 to 5500 Ft. Altitudes	5500 to 7000 Ft. Altitudes	7000 to 10,000 Ft. Altitudes		
VHS-30, 60, 90 and 120	30	30	30	6	2
VHS-150	30	30	15	6	2
VHS-180	30	15	15	6	2

Flex-L StaR-34 and Z-Flex Z-Vent System

Boiler Model No.	Max. Equivalent Length (Ft.)			Equivalent Length of each 90° Elbow, Ft.	Minimum Length, Ft.
	0 to 5500 Ft. Altitudes	5500 to 7000 Ft. Altitudes	7000 to 10,000 Ft. Altitudes		
VHS-30, 60, 90 and 120	35	35	35	6	2
VHS-150	35	35	18	6	2
VHS-180	35	18	18	6	2

Note: Vent termination is in addition to the allowed equivalent length.

“VICTORY II HORIZONTAL VENTING”

All joints must be liquid and pressure tight. Use U/L listed single wall 3" dia. AL29-4C* S.S. venting materials (See page 5)

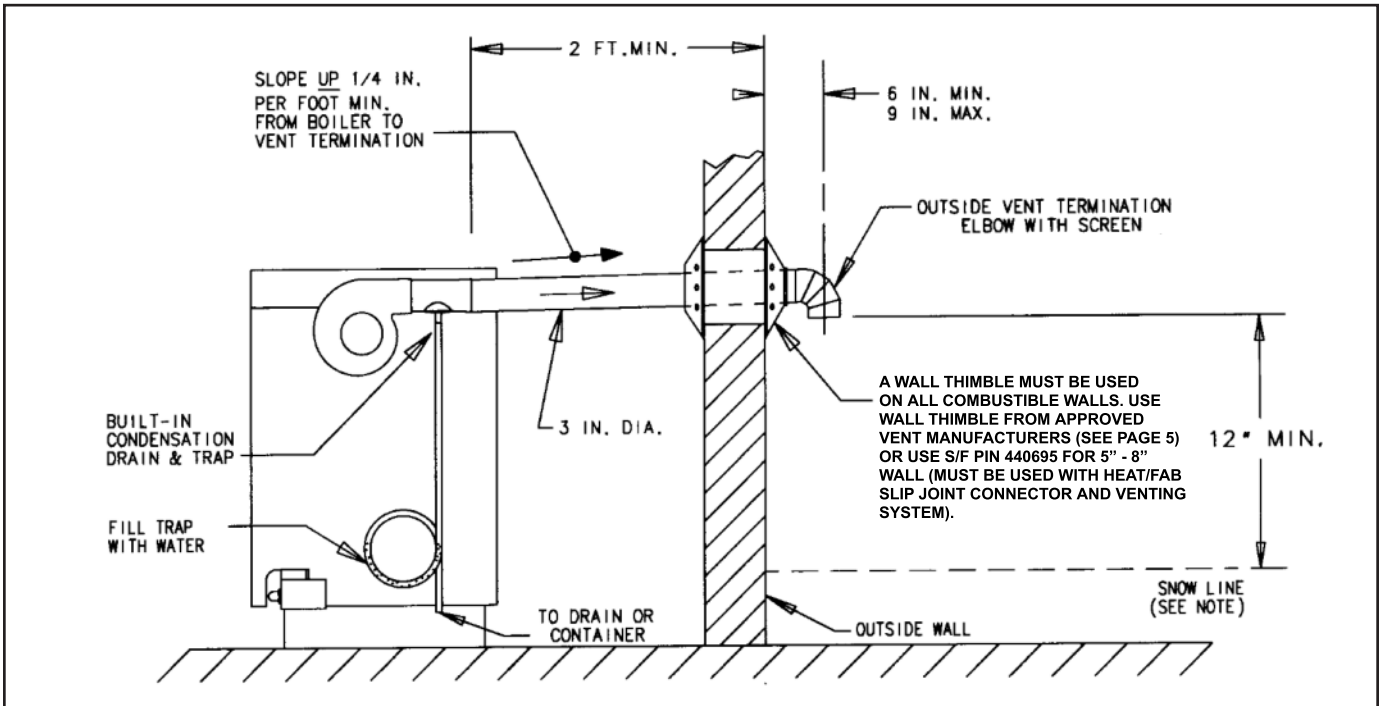

Figure 5. * Definition of Snow Line: Knowledge of local conditions will reveal the maximum height that repeated snowfalls accumulated to. The height should be used as the SNOW LINE.

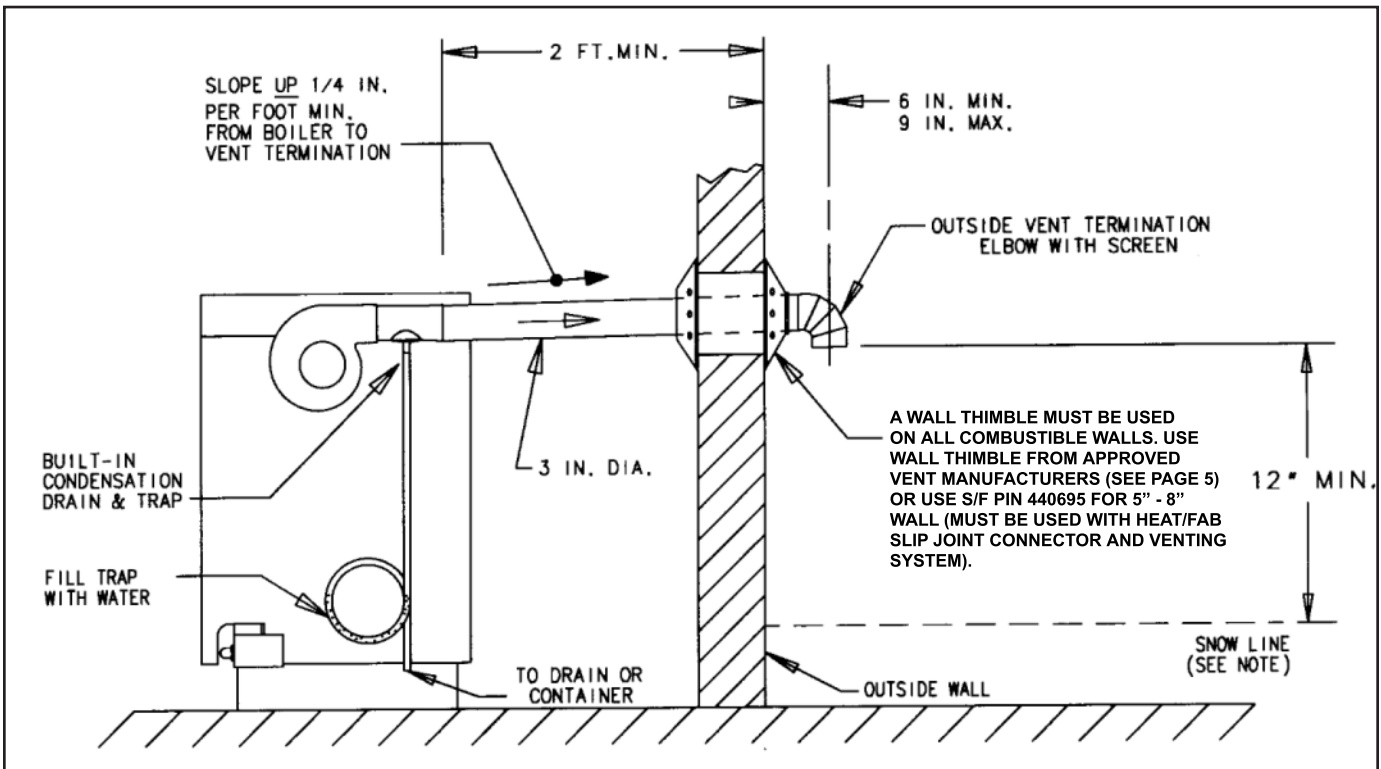

Figure 6. * Definition of Snow Line: Knowledge of local conditions will reveal the maximum height that repeated snowfalls accumulated to. The height should be used as the SNOW LINE

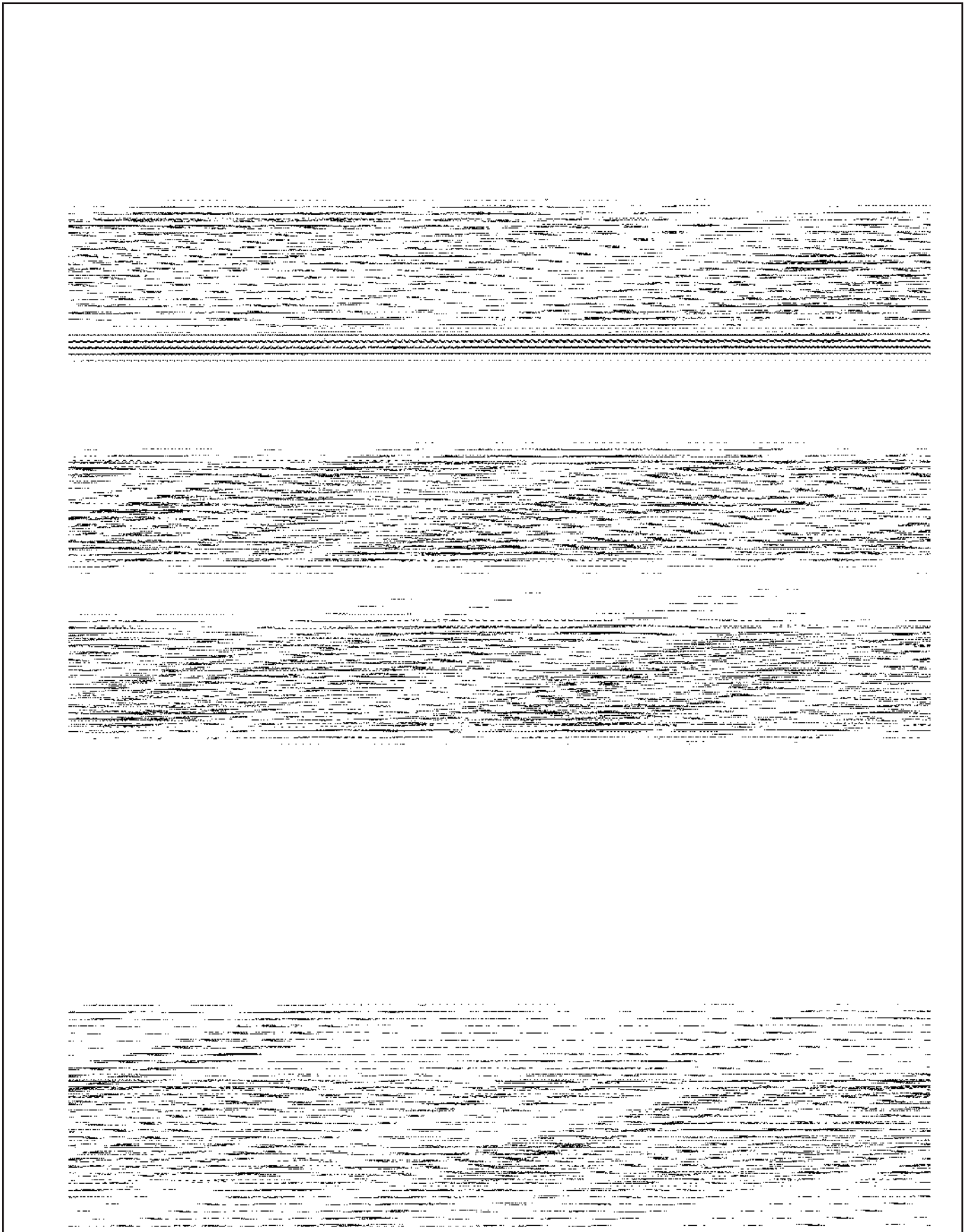

Figure 7.

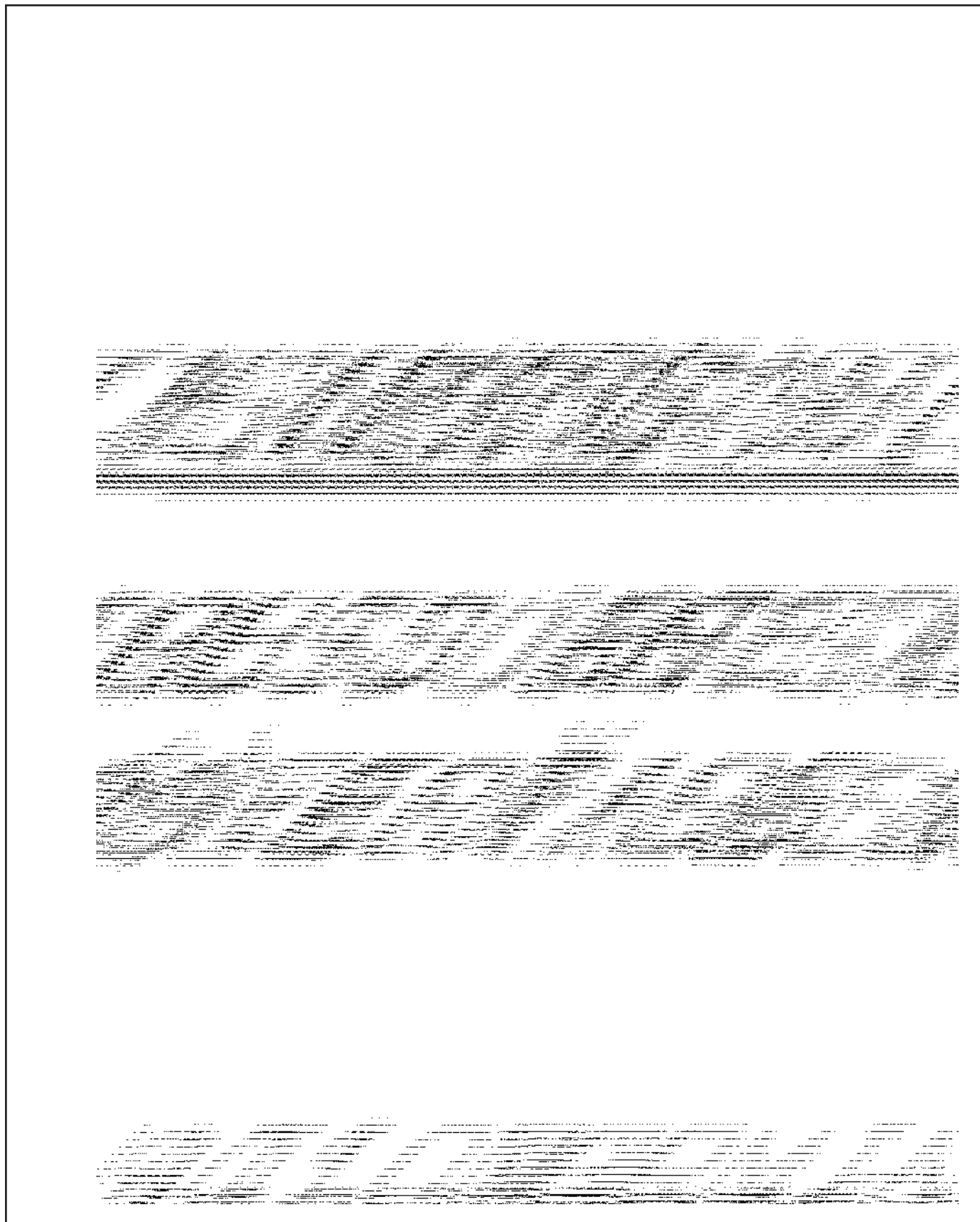

Figure 8.

CATEGORY I VENTING (Natural Draft Chimney and Type "B" Venting)

1. Installation

Model VHS-90, VHS-120, VHS-150 and VHS-180 may be vented into a natural draft masonry chimney or natural draft type "B" vent if a 3" diameter stainless steel elbow connected to the boiler's flue collar and the vent connector converted to 5" diameter using a 3" x 5" vent adapter. Single or multiple appliance venting are shown in Figures 9 and 10.

2. Vent Connector Material

Vent connectors may be single wall or Type "B" made of galvanized or stainless steel materials.

3. Venting Requirements

If the boiler vent is to be installed into a natural draft masonry chimney or Type "B" venting, it must be in accordance with National Fuel Gas Code ANSI Z223.1-latest edition, Part 12, Part 13 and Appendix G.

For a masonry vitreous tile-lined chimney which is not exposed to the outdoors, use Table 1 in this Slant/Fin manual for venting requirements. DO NOT install this system into an unlined masonry chimney.

If a masonry chimney is exposed to the outdoors on one or more sides below the roof line (exposed chimney), it must be re-lined with a UL listed metallic liner system. See Table 2 in this Slant/Fin manual for venting requirements of metallic re-lined chimneys.

If a Type "B" vent system is used, it must NOT be exposed to the outdoors below the roof line. See Table 2 in this Slant/Fin manual for venting requirements. Vent connectors serving appliances vented by natural draft shall NOT be connected into any portion of mechanical draft systems operating under positive pressure.

In some cases, the vent connector diameter must be up-sized further to 6" or 7". Refer to Table 1 and 2 for installations requiring this increased size.

If this boiler is replacing a boiler which is connected to a common venting system with other natural draft, gas-fired appliances, the removal of the existing boiler from the venting system is likely to cause the system to be too large for proper venting of the appliances remaining connected to it. At the time of removal of the existing boiler, the test procedure specified in Appendix "B" must be followed.

Natural Draft Chimney and Type “B” Venting Tables

Table 1. Masonry Vitreous Tile-Lined Chimney (not metal lined)

Chimneys not exposed to the outdoors below the roof line. (5" dia. vent adapter must be used)

Boiler Model(s) †	Additional Gas Appliance in Venting System	Connector	Requirements*	National Fuel Gas Code Reference Table No.* (ANSI Z223.1)
VHS-90 VHS-120 VHS-150 VHS-180	No	Type “B”	1. Connector diameter must be upsized to 7". 2. Chimney height limits: Min. 15 ft., Max. 30 ft. 3. Lateral length restriction applies (Table 13.1 (c)) 4. Internal area of chimney: Min. 50 sq. in., Max. 269 sq. in.	13.1 (c) (2006 edition)
VHS-180	No	Single-wall	1. Connector diameter must be upsized to 7". 2. Chimney height limits: Min. 15 ft., Max. 30 ft. 3. Max. lateral length may not exceed 2 ft. 4. Internal area of chimney: Min. 50 sq. in., Max. 269 sq. in.	13.1 (d) (2006 edition)
VHS-90 VHS-120 VHS-150 VHS-180	Yes	Type “B”	1. See Table 13.2 (c) for chimney height and connector length restrictions. 2. Connector may have to be upsized to 6" diameter to meet requirement of 10-8.	13.2 (c) (2006 edition)
VHS-150 VHS-180	Yes	Single-wall	1. See Table 13.2 (d) for chimney height and connector length restrictions. 2. Connector may have to be upsized to 6" diameter to meet requirement of 13.2 (d).	13.2 (d) (2006 edition)

Table 2. Type “B” Venting and Metal-Lined Masonry Chimney

UL LISTED MATERIALS ONLY. (5" dia. vent adapter must be used)

Boiler Model(s) †	Additional Gas Appliance in Venting System	Connector	Requirements*	National Fuel Gas Code Reference Table No.* (ANSI Z223.1)
VHS-90 VHS-120 VHS-150 VHS-180	No	Type “B”	See Table 13.1 (a) for minimum and maximum of vent height and lateral length restriction.	13.1 (a) (2006 edition)
VHS-90 VHS-120 VHS-150 VHS-180	No	Single-wall	See Table 13.1 (b) for minimum and maximum of vent height and lateral length restriction.	13.1 (b) (2006 edition)
VHS-90 VHS-120 VHS-150 VHS-180	Yes	Type “B”	1. See Table 13.2 (a) for vent height and connector length restrictions. 2. Connector and vent diameter may have to be increased to 6" or 7" to meet requirement of Table 13.2 (a).	13.2 (a) (2006 edition)
VHS-120 VHS-150 VHS-180	Yes	Single-wall	1. See Table 13.2 (b) for vent height and connector length restrictions. 2. Connector and vent diameter may have to be increased to 6" to meet requirement of Table 13.2 (b).	13.2 (b) (2006 edition)

† Only Victory II boiler models shown for each application permitted to be installed in that manner specified.

• Also see ANSI Z223.1 — 2006 Chapter 12 and 13.

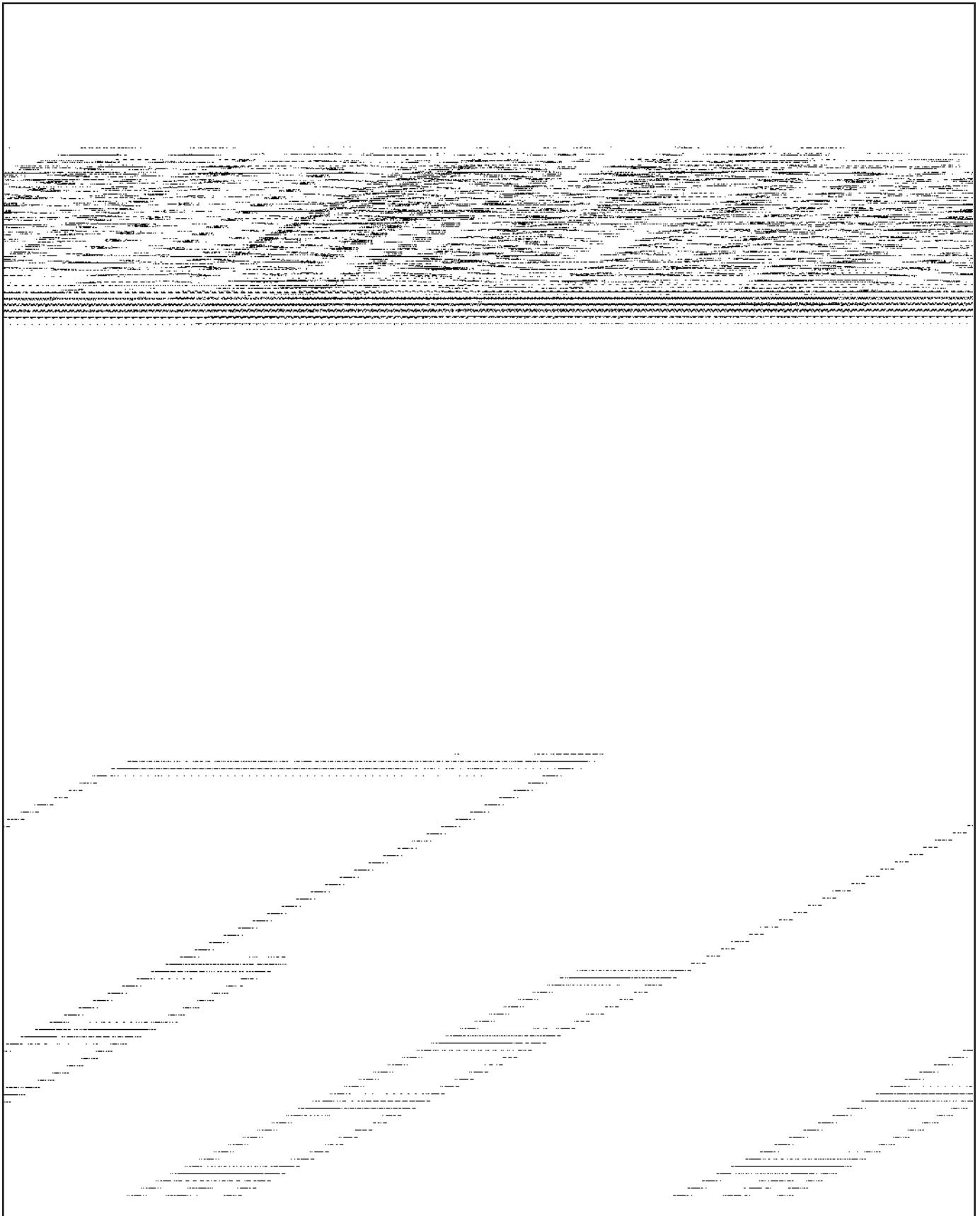

Figure 9.

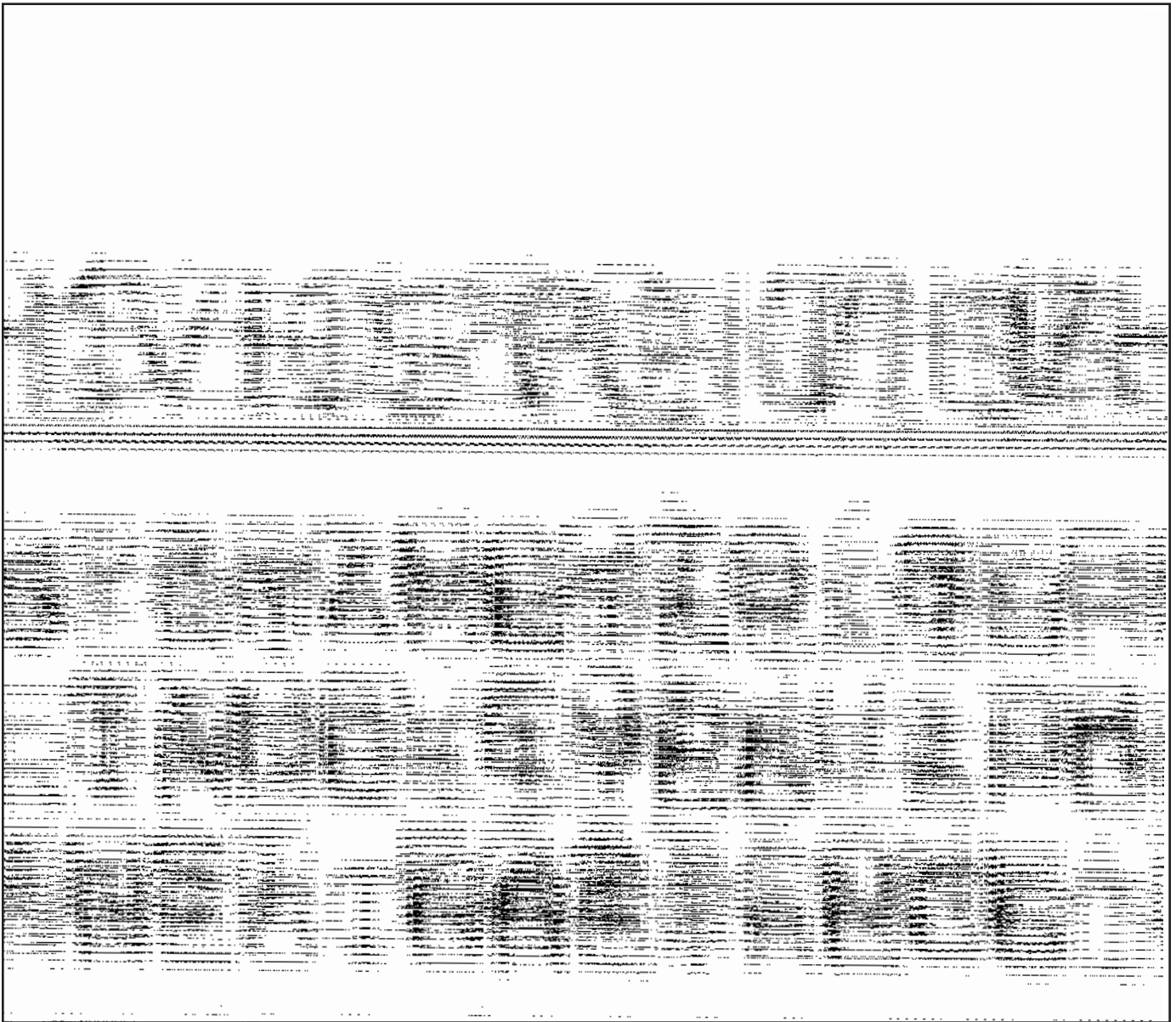

Figure 10.

VENTING SYSTEM REGULAR INSPECTION

- A. Inspect the system regularly for condensation, corrosion and/or physical damage. A qualified professional should service the boiler annually and include such an inspection at that time. The homeowner should look over the system monthly for damage, water stains, any signs of rust, other corrosion or separation of the flue (vent) tubing and fittings.
- B. Should an inspection turn up signs of condensation, corrosion or damage, the boiler should be shut down immediately and the condition should be corrected by a qualified professional.
- C. All Victory II boilers are equipped with a built-in condensation drain and trap. The trap loop must be filled with water. DO NOT operate the boiler without filling the trap with water to prevent flue gas discharge into space. Periodic inspection should be made of this assembly for deterioration of the tubing and to insure that the trap is not plugged. If it is plugged or appears to have excessive sediment in it, it should be removed from the drain assembly, straightened out to clear the obstruction, reformed, filled with water and reinstalled as before.

GAS PIPING

- A. Local installation codes apply. The pipe joint compound used on threads must be resistant to the action of liquefied petroleum gases.
- B. The gas supply line to the boiler should be run directly from the meter for natural gas or from the fuel tank for L.P. propane gas. See page 2 for location of union and manual main shut-off valve that may be specified locally.
Selecting pipe size for natural gas:
 1. Measure or estimate the length of piping from the meter to the installation site.
 2. Consult gas supplier for heating value of gas (Btu/cu. ft.).
 3. Divide boiler rated input by heating value to find gas flow in piping (cu. ft. per hour).
 4. Use table below to select proper pipe size.

Example: Boiler model VHS-150 is to be installed. Distance from gas meter to the boilers is 30 ft. Heating value of natural gas is 1020 Btu/cu. ft. Select proper pipe size.

$$\text{Gas flow} = \frac{150,000 \text{ Btu/hour}}{1020 \text{ Btu/cu. ft.}} = 147 \text{ cu. ft. per hour}$$

At 30 ft. length of pipe, match required capacity from table on this page (choose higher capacity, in this case is 152 cu. ft. per hour). Required pipe size is 3/4".

Improper gas pipe sizing will result in pilot flame outages, insufficient heat and other installation difficulties. For more information and also if other appliances are to be attached to the piping system, see Appendix C of National Fuel Gas Code ANSI Z223.1-latest edition.

- C. The boiler and its gas connection must be leak tested before placing the boiler in operation. Use liquid soap solution for all gas leak testing. DO NOT use open flame. This boiler and its individual shutoff valve must be disconnected from the gas supply piping system during any pressure testing of that system at test pressures in excess of 1/2 PSIG. This boiler must be isolated from the gas supply piping system by closing its individual manual shutoff valve during any pressure testing of the gas supply piping system at test pressures equal to or less than 1/2 PSIG.
- D. All gas piping used should be inspected thoroughly for cleanliness before makeup. A sediment trap must be provided, as illustrated on page 2.

Length of pipe in Feet	Gas Flow In piping -- cu. ft. per hr.				
	Iron Pipe Size (IPS) — inches				
	1/2	3/4	1	1 1/4	1 1/2
10	132	278	520	1050	1600
20	92	190	350	730	1100
30	73	152	285	590	890
40	63	130	245	500	760
50	56	115	215	440	670
60	50	105	195	400	610
70	46	96	180	370	560
80	43	90	170	350	530
90	40	84	160	320	490
100	38	79	150	305	460

At pressure drop of 0.3 in. water, specific gravity = 0.6.

- E. The minimum and maximum gas supply pressure (at the inlet of gas valve) are shown on the boiler rating plate for the type of gas used. Gas supply pressure should never be less than minimum or more than maximum pressure when the boiler or any other appliance is turned on or off.

ELECTRICAL WIRING

DANGER: Before wiring, always turn off electric power supply, otherwise, shock or death can result.

1. Power Supply

A separately fused circuit is recommended. Use a standard 15 Amp. fuse or breaker and 14 gage conductors in BX cable or conduit.

Provide disconnect means and overload protection as required. See boiler wiring diagram (Figure 11a).

Boiler must be electrically grounded in accordance with the requirements of the authority having jurisdiction, or, in the absence of such requirements, with the National Electrical Code, ANSI/NFPA 70-latest edition.

2. Power Connection

- A. Remove electrical junction box cover.
- B. Hot connection lead is black. Neutral connection lead is white.
- C. Connect ground wire to ground screw inside the junction box.
- D. Replace junction box cover.

3. Thermostat Connections

Thermostat wire connections must be to T and TV screw terminals of boiler temperature control (See Figure 11b).

Thermostat Heat Anticipator Adjustments

If the 24v room thermostat that controls this boiler has an adjustable heat anticipator, connect entire system to thermostat and run the system while measuring the current drawn through the thermostat wires. Set the heat anticipator at the value measured. The set current should match power requirements by zone valves and relays. Refer to the manufacturer's instruction of zone valve, and relays. Also, see instructions with the thermostat.

4. Multi Zoning

For pump zoning system, see Figures 12 and 14, for zone valve system, see Figure 13. DO NOT use boiler transformer to power external accessories like zone valve and relays, overload and/or burned-out transformer and boiler malfunction can result.

5. Indirect External Water Heater

If system includes indirect water heater, the indirect signal must be separated from heating zones(s) system. See figure 14 and 15. Follow steps below:

- a. Connect end switch of the indirect water heater relay to I1 and I2 of the boiler temperature control.
- b. Connect end switch of the heating zones(s) relays to T and TV of the boiler temperature control.
- c. Power DHW and heating zone(s) circulators through end switch relays as shown on figure 14. Do not connect heating zone(s) circulators to C1 and C2 of the control.

Note: For single heating zone with external indirect water heater. See figure 16.

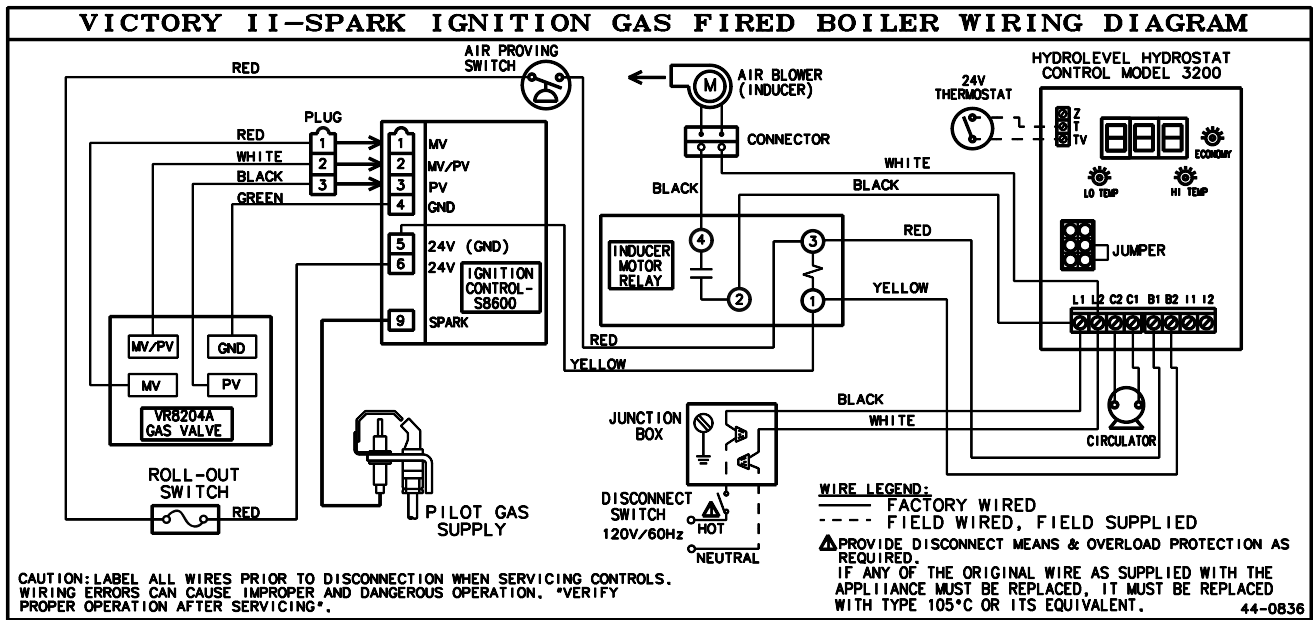

Figure 11a. Wiring diagram for boilers equipped with Hydrolevel Hydrostat Control

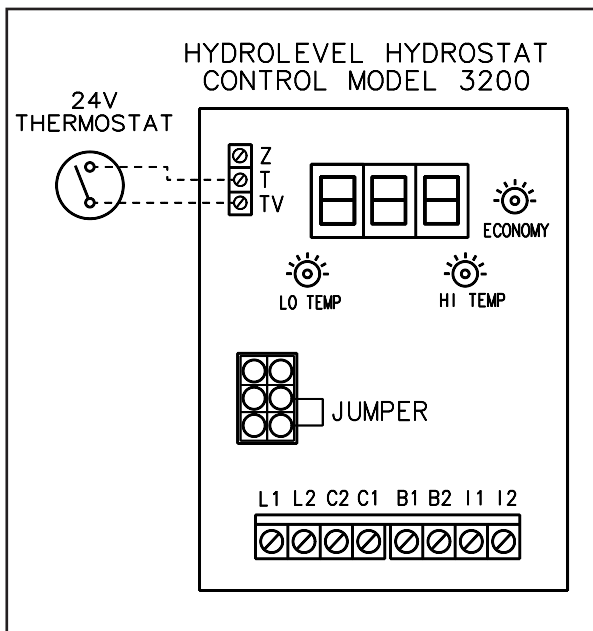

Figure 11b.

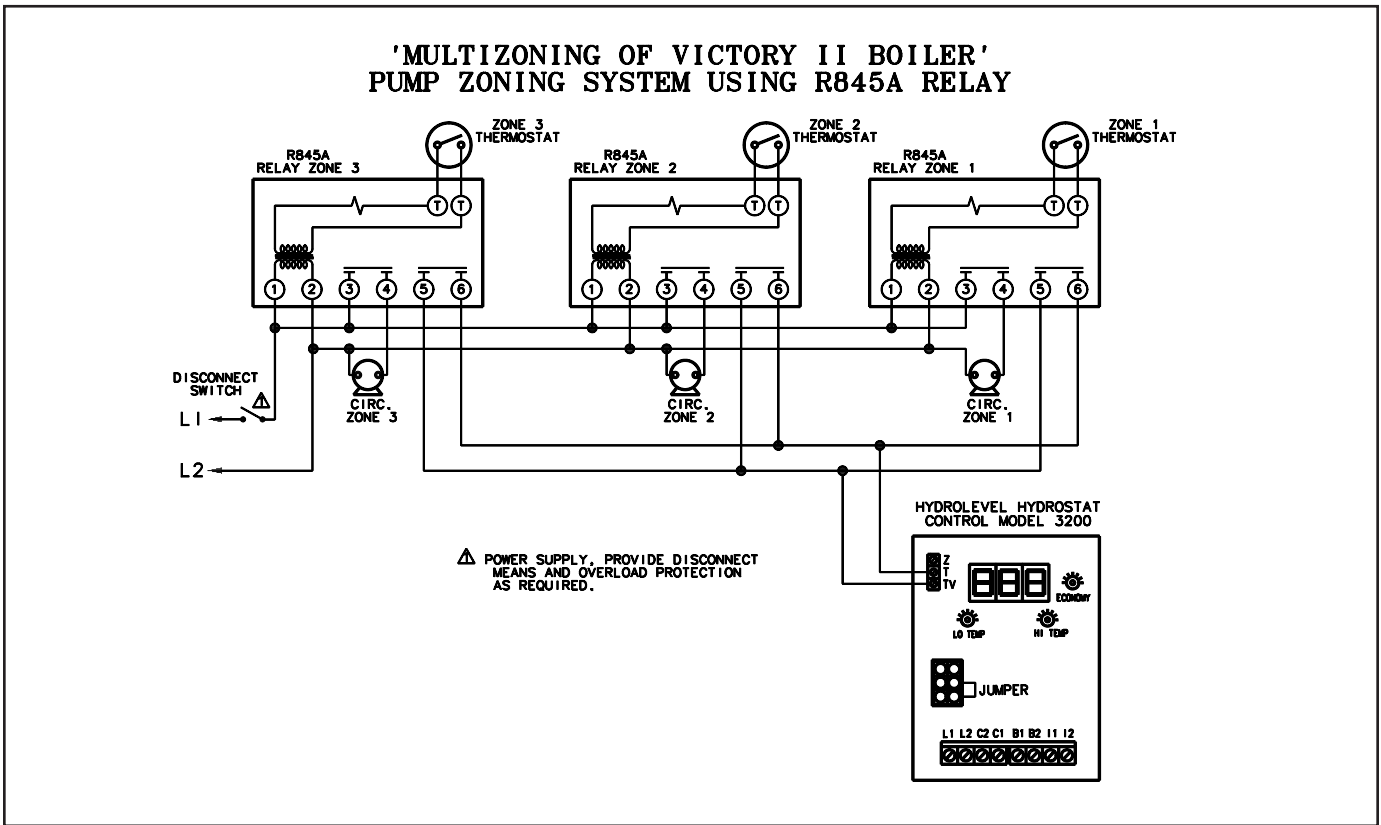

Figure 12.

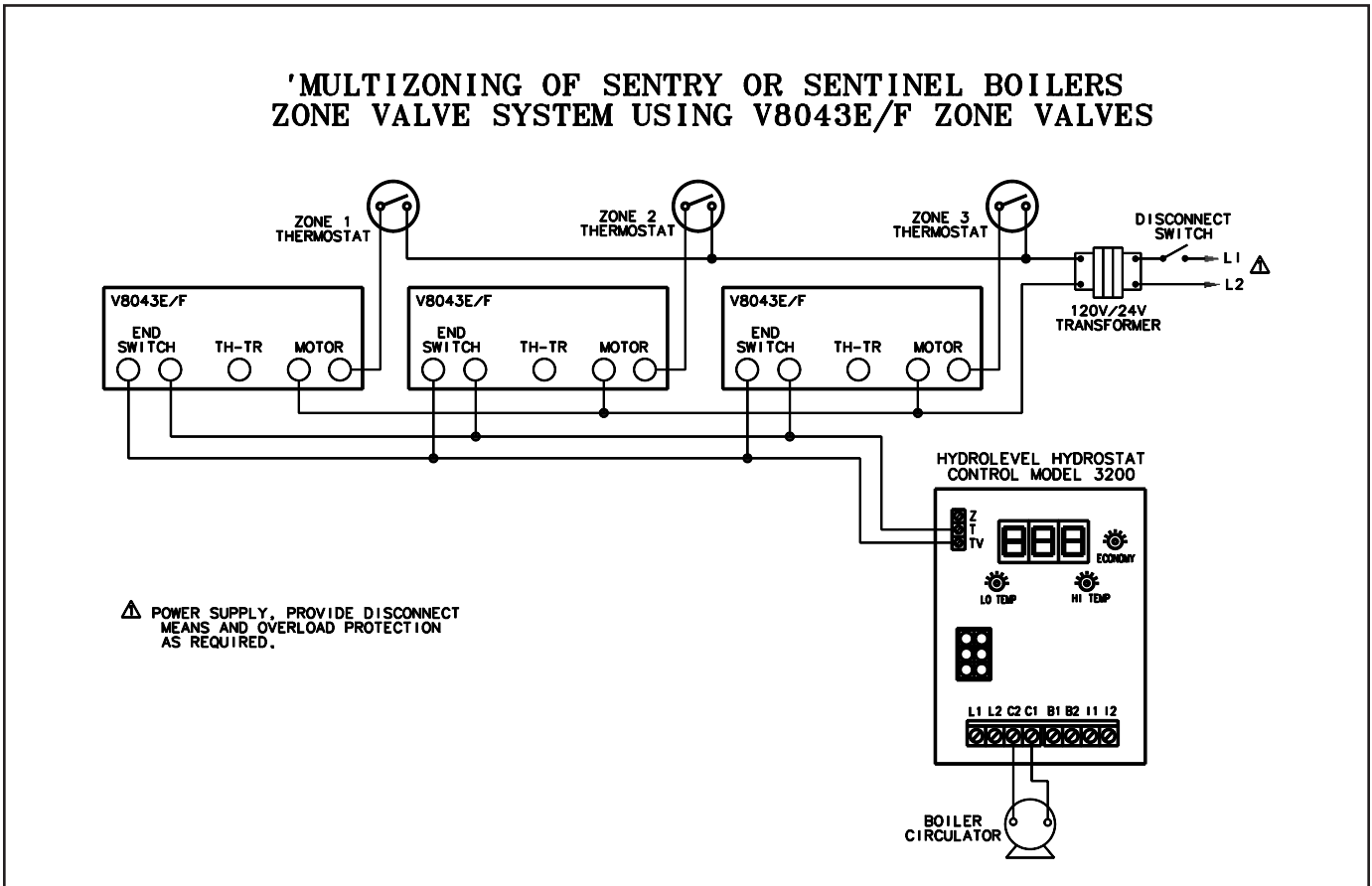

Figure 13. Multizoning of VHS boilers zone valve system using V8043E/F zone valves

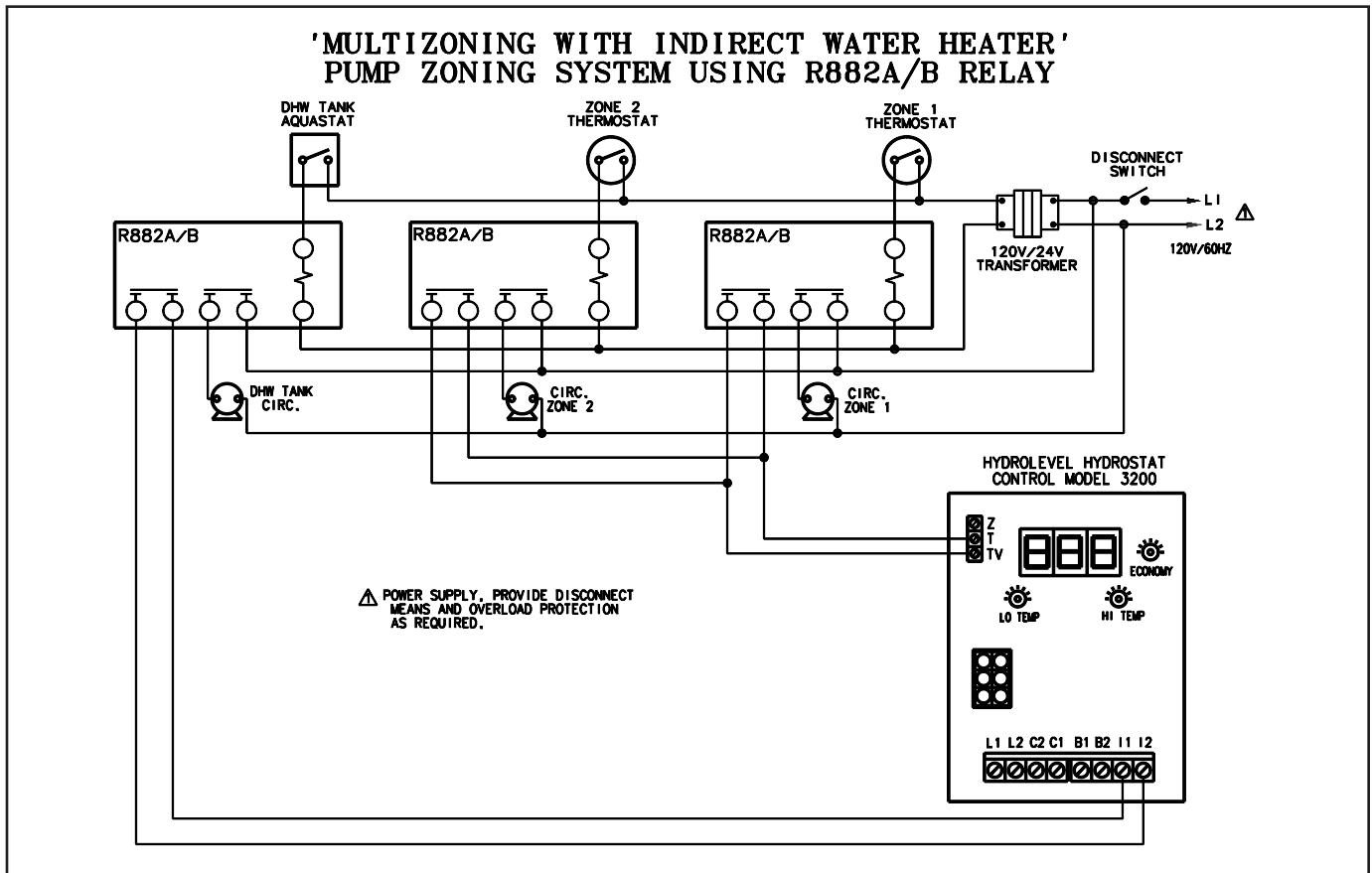

Figure 14.

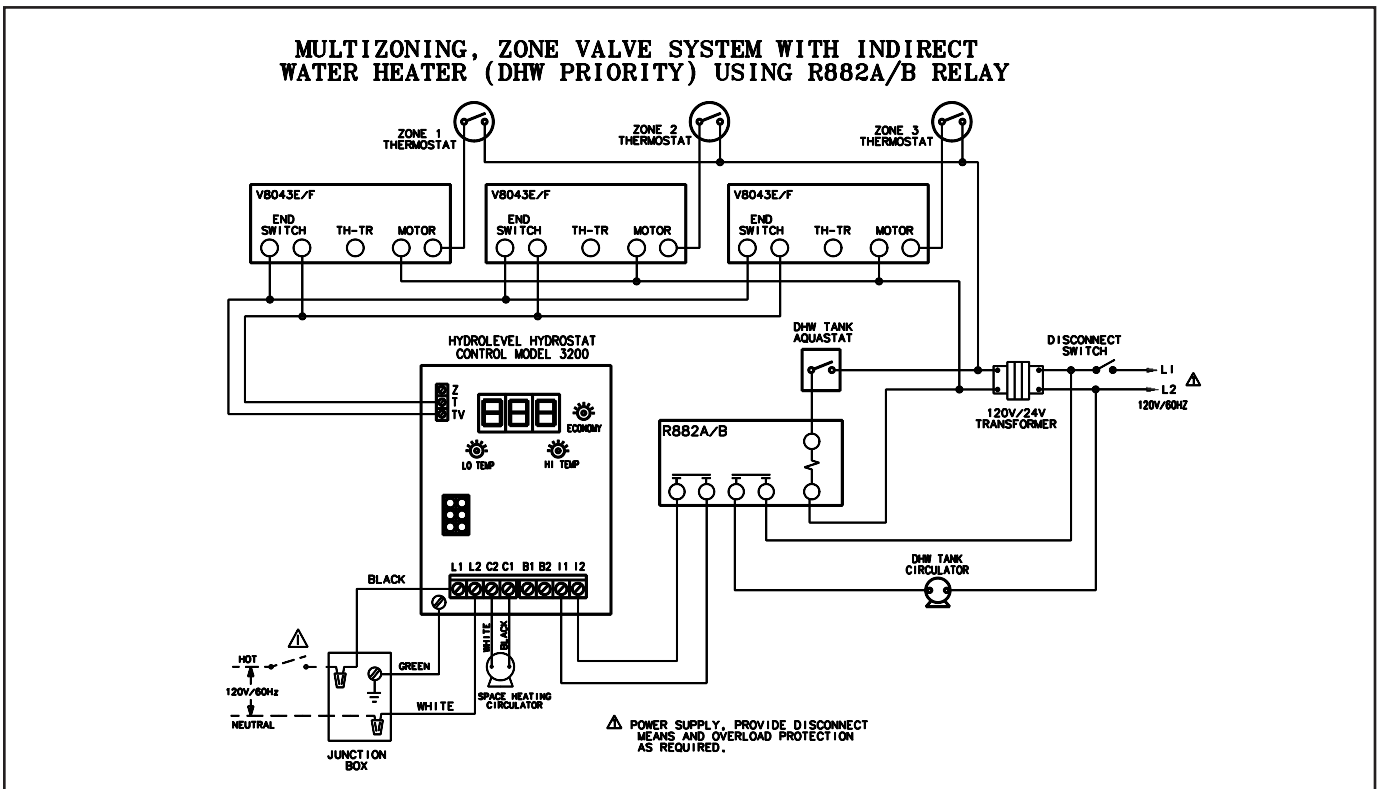

Figure 15.

SINGLE ZONE WITH INDIRECT WATER HEATER (DHW PRIORITY) USING R882A/B RELAY

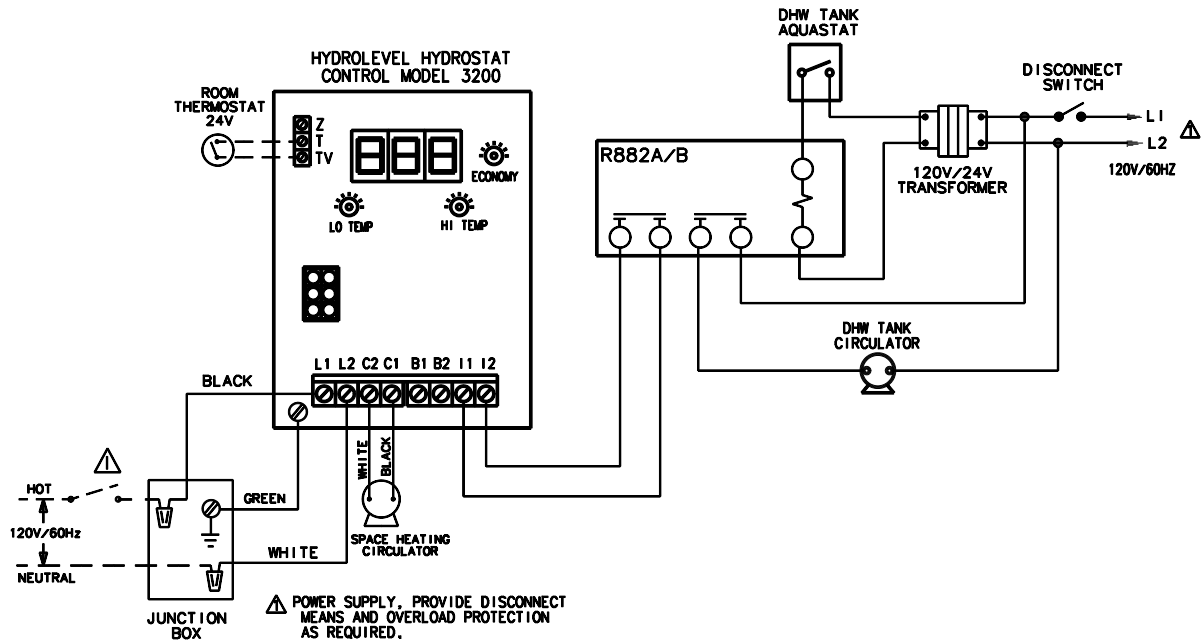

Figure 16.

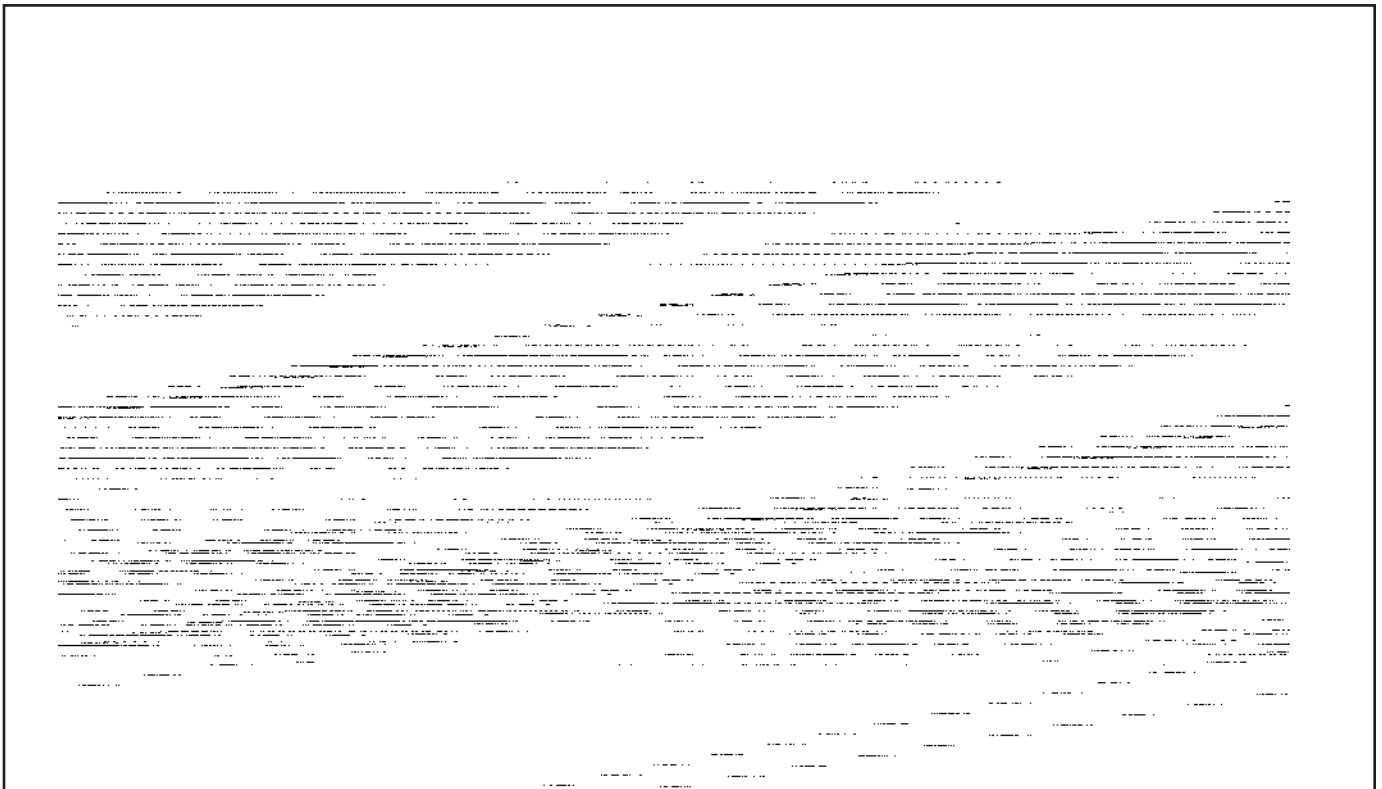

Figure 17. Piping Arrangement

BOILERS EQUIPPED WITH HYDROSTAT CONTROL

SETTING THE CONTROL

NOTE: Settings can be checked using the TEST/SETTINGS Button.

SETTING THE HIGH LIMIT

The high limit is factory set at 190°F. To adjust, turn the HI TEMP Dial **A** until the desired setting is displayed. (Setting range: 100°-220°F)

SETTING THE LOW LIMIT

The low limit is designed to maintain temperature in boilers equipped with tankless coils used for domestic hot water. The low limit is factory set to OFF. Prior to adjusting, remove the jumper (not equipped on all units) **B**. Then turn the LO TEMP Dial **C** clockwise until the desired temperature is displayed. For proper operation, the low temperature limit setting should be at least 10° below the high limit setting. **NOTE:** For cold start operation, the low limit must be turned OFF. **IMPORTANT:** If low limit temperature cannot be set above 140°F, remove jumper **B**. (Setting range: OFF or 110°-200°F).

SETTING THE ECONOMY FEATURE

The Economy Feature is factory set for a 1 zone heating system. To adjust, turn the ECONOMY Dial **D** until the number displayed equals the number of heating zones. Do not include indirect water heaters in the number of heating zones. The Economy Feature conserves fuel by reducing boiler temperature (see "How Thermal Targeting Works" below). If the heating system is unable to supply needed heat to the house, the ECONOMY Dial should be turned to a lower setting (example: In a three zone house, turn the dial to 2 or 1). Conversely, if the boiler provides adequate heat, added fuel savings can be achieved by selecting a higher setting (example: 4 or 5). If the heating and indirect water heater signals were not separated when wiring the control, the Economy Feature should be turned OFF to insure the boiler supplies adequate temperature to heat the indirect tank.

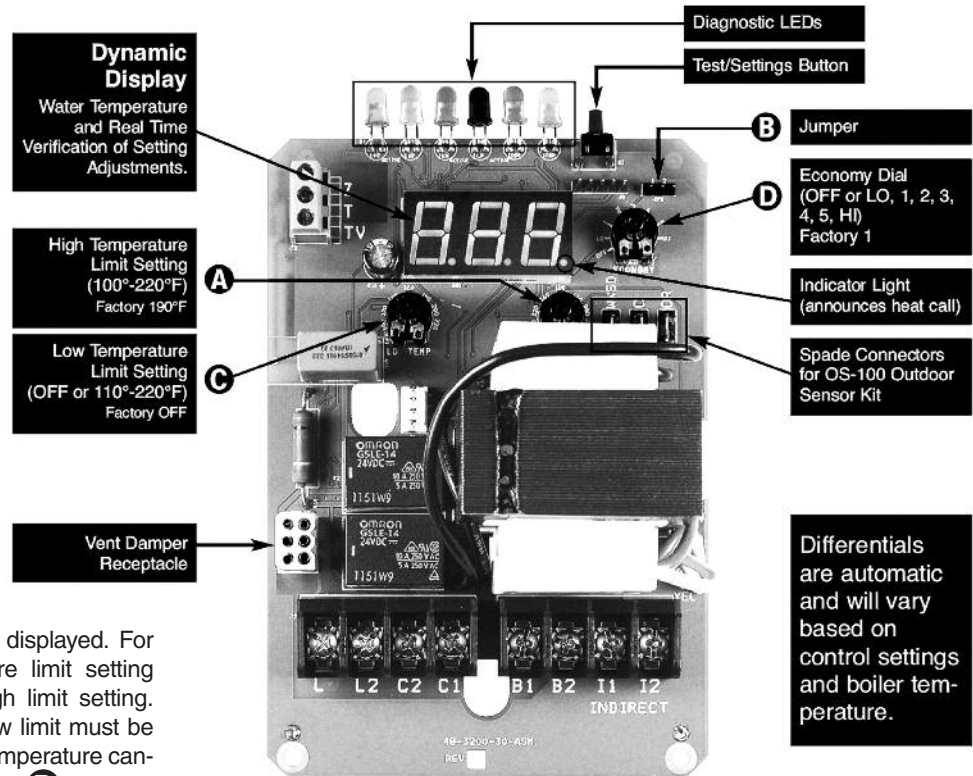

IMPORTANT NOTICE

This boiler is equipped with a feature that saves energy by reducing the boiler water temperature as the heating load decreases. This feature is equipped with an override which is provided primarily to permit the use of an external energy management system that serves the same function. **THIS OVERRIDE MUST NOT BE USED UNLESS AT LEAST ONE OF THE FOLLOWING CONDITIONS IS TRUE:**

- An external energy management system is installed that reduces the boiler water temperature as the heating load decreases.
- This boiler is not used for any space heating.
- This boiler has an input of 300,000 BTU/hr or greater
- This boiler is part of a modular or multiple boiler system having a total input of 300,000 BTU/hr or greater.
- This boiler is equipped with a tankless coil.

SETTING OFF	Disables economy function. Will allow boiler to fire until hi limit temp is reached and re-fire with a 10° subtractive differential.
LO	Provides lowest level of fuel savings. Use this setting only if the house does not stay warm at higher settings.
1	Recommended setting for single zone systems
2	Recommended setting for Two zone systems
3	Recommended setting for Three zone systems
4	Recommended setting for Four zone systems
5	Recommended setting for Five zone systems
HI	Provides highest level of fuel savings

OPTIONAL FEATURES

NOTE: The Program Mode – Pro – is accessed by turning the LO TEMP dial to a position just above OFF.

THERMAL PRE-PURGE

Thermal Pre-Purge is designed to maximize boiler efficiency. When activated, the control will supply latent heat that may remain in the boiler from a previous run cycle to the next heating zone that calls. The control monitors how quickly the boiler temperature is declining and activates the burner only when it determines that the latent heat is insufficient to satisfy the call. During the purge cycle, the display will indicate Pur. This feature works with single-zone and multi-zone heating systems utilizing circulators or zone valves. No change in wiring is needed.

To activate Thermal Pre-Purge

1. Turn the LO TEMP dial to access the Program Mode – indicated in the display as Pro
2. Turn the HI TEMP dial to select feature 1
3. Push the Test/Settings Button to turn Thermal Pre-Purge on or OFF
4. Reset LO TEMP and HI TEMP settings to desired temperatures (see page 19)

Note: Activation of this feature is not recommended for boilers with tankless coils.

DEGREES FAHRENHEIT OR CELSIUS

The control has the ability to operate in degrees Fahrenheit or Celsius. When operating in Celsius, a C will appear in the display next to the temperature whenever the temperature is below 100 degrees.

To change between degrees Fahrenheit and degrees Celsius

1. Turn the LO TEMP dial to access the Program Mode – indicated in the display as Pro
2. Turn the HI TEMP dial to select feature 2
3. Push the Test/Settings Button to C for Celsius or F for Fahrenheit
4. Reset LO TEMP and HI TEMP settings to desired temperatures (see page 19)

MANUAL RESET LOW WATER CUT-OFF

The low water cut-off operation on the HydroStat can be set to operate in automatic (default) or manual reset mode. When in manual reset mode, the control will shut-down the burner immediately when a low water condition is detected. If the low water condition is sustained for 30 seconds, the low water light will blink, indicating that the control has locked out the burner. The control can only be reset by pushing the Test Settings button on the top of the control. The manual reset feature meets CSD-1 code requirements.

IMPORTANT: The system must be checked by a qualified heating professional prior to resuming operation.

WARNING: DO NOT ADD WATER UNTIL THE BOILER HAS FULLY COOLED.

To activate Manual Reset LWCO mode

1. Turn the LO TEMP dial to access the Program Mode – indicated in the display as Pro
2. Turn the HI TEMP dial to select feature 3
3. Push the Test/Settings Button to R for Automatic Reset Mode or b for Manual Reset Mode
4. Reset LO TEMP and HI TEMP settings to desired temperatures (see page 19)

To Test the Manual Reset Feature: Press and hold the Test/Settings button located on the top of the control for 30 seconds to simulate a low water condition. After 30 seconds, the Low Water light will blink indicating that the control is locked out. To reset the lock-out condition, press the Test/Settings button momentarily.

MORE OPTIONAL FEATURES ON NEXT PAGE

OPTIONAL FEATURES *Continued*

CIRCULATOR ACTIVATION OPTIONS

When in the default mode, the HydroStat activates the circulator (C1/C2 contacts) on calls to T/TV. The control can be programmed to activate the circulator on calls to I1/I2 in place of, or in addition to, calls to T/TV.

To change how the Circulator is activated

1. Turn the LO TEMP dial to access the Program Mode – indicated in the display as Pro
2. Turn the HI TEMP dial to select feature 4
3. Push the Test/Settings Button to select between the following options:
 - Circulator on **T/TV** call only
 - Circulator on **I1/I2** call only
 - Circulator on both **T/TV & I1/I2** calls
4. Reset LO TEMP and HI TEMP settings to desired temperatures (see page 19)

CIRCULATOR HOLD OFF (ENHANCED CONDENSING PROTECTION)

To reduce the potential for condensing, on a call for heat the control will allow the boiler to heat to 125°F prior to energizing the circulator. Once energized, the circulator will remain on for the duration of the heating call unless the boiler temperature drops below 115°F. If this occurs, the circulator will re-energize when the boiler returns to 125°F.

To activate Circulator Hold Off

1. Turn the LO TEMP dial to access the Program Mode – indicated in the display as Pro
2. Turn the HI TEMP dial to select feature 5
3. Push the Test/Settings Button to turn Circulator Hold Off or OFF
4. Reset LO TEMP and HI TEMP settings to desired temperatures (see page 19)

LOW WATER CUT-OFF FUNCTION

To turn off Low Water Cut-Off

1. Turn the LO TEMP dial to access the Program Mode – indicated in the display as Pro
2. Turn the HI TEMP dial to select feature B
3. Push the Test/Settings Button to turn Low Water Cut-Off or OFF
4. Reset LO TEMP and HI TEMP settings to desired temperatures (see page 19)

OUTDOOR RESET READY AND WARM WEATHER SHUTDOWN

Hydrostat Control model 3200 - PLUS features outdoor reset ready (must use optional kit part no. 430423000)
See installation instructions packed with the kit.

Outdoor Reset and Warm Weather Shutdown

Attach the spade connectors to the right and center posts (OR and C) for full outdoor reset functionality including warm weather shutdown protection. Wiring this way overrides the Thermal Targeting function of the Fuel Smart HydroStat control. (See pg.10)

Warm Weather Shutdown Only

Connect the wire ends to the left and center spade connectors (WWSD and C) to add Warm Weather Shutdown functionality only. When wired this way, the Fuel Smart HydroStat control will utilize its internal Thermal Targeting function to reset the boiler temperature. (See pg.19)

OPTIONAL FEATURES *Continued*

RESTORE FACTORY DEFAULT SETTINGS

To restore all features to the factory default settings (see following chart for default settings)

1. Turn the LO TEMP dial to access the Program Mode – indicated in the display as Pro
2. Turn the HI TEMP dial to select feature dEF
3. Push the Test/Settings Button to \mathcal{Y} to reset all features to the default settings.
4. Reset LO TEMP and HI TEMP settings to desired temperatures (see page 19)

Dial Setting	Feature	Options	Description	Default Setting	Record Your Settings
1	Thermal Pre-Purge	OFF ON	Purge Inactive Purge Active	OFF	
2	Fahrenheit or Celsius	F C	Degrees Fahrenheit Degrees Celsius	F	
3	LWCO Manual or Automatic Reset	A B	Automatic Reset Manual Reset	A	
4	Circulator Options	A B C	Circulator operation on T/TV call only Circulator operation on I1/I2 call only Circulator operation on call from either	A	
5	<i>Circulator Hold Off</i>	ON OFF	Circulator Hold Off – Active Circulator Hold Off – Inactive	OFF	
6	<i>Not available on this control</i>				
7	<i>Not available on this control</i>				
8	Low Water Cut-Off Function	ON OFF	Low Water Cut-Off ON Low Water Cut-Off OFF	ON	
dEF	Restore Factory Defaults	Y N	Restore Defaults * Do Not Restore Defaults	N	

SEE PAGE 19 FOR ADDITIONAL SETTINGS

*: “Circulator Hold Off” feature would be “Active” if defaults are restored. Turn it OFF (Inactive) if required.

SYSTEM START-UP

At initial start up, with the Economy Feature active, the control establishes a 145°F target temperature. To test the high limit shut-off function, the Economy Dial must be turned to OFF. Once tested, restore the Economy setting. If the heating demand is high, the target will increase over time to satisfy the heat load.

NOTE:

Smart DHW Priority : During a call from indirect water heater, the control will de-energize the circulator contacts (C1/C2) to heat only the indirect tank ensuring an adequate supply of domestic hot water. The control will re-energize the circulator when the indirect tank is satisfied or if the boiler temperature reaches 170°F. If the indirect call continues for 45 minutes, the control will override the priority function energizing the circulator to provide space heating.

HOW THERMAL TARGETING WORKS

Thermal Targeting technology analyzes thermostat activity and continually evaluate how much heat the house requires. When it is very cold outside, the heat demand is high and the Fuel Smart HydroStat will raise the boiler s Target temperature to provide needed heat to the home. When the outside temperature is milder, the heat demand is lower. During these periods, the Fuel Smart HydroStat will lower the boiler s Target temperature – saving fuel – while continuing to provide comfort to the house.

LED LEGEND and TEST/SETTINGS BUTTON

① **TEMP ACTIVE** Indicates that the Fuel Smart HydroStat control is powered and that the temperature function is active.

② **TEMP HIGH TEMP** Illuminates when the boiler water temperature reaches the high limit setting. It will remain lit until the water temperature falls 10° (see High Limit Differential on page 4). The Fuel Smart HydroStat prevents burner operation while this LED is on.

③ **LWCO ACTIVE** Indicates that the low water cut-off (LWCO) function of the Fuel Smart HydroStat is active. When the control is installed with a Hydrolevel Electro-Well, this LED will be on at all times when the control is powered.

IMPORTANT: If the control is installed with a well other than the Electro-Well, this LED will not illuminate indicating that the control is not providing low water cut-off functionality.

④ **LWCO LOW WATER** Illuminates if the boiler is in a low water condition. The Fuel Smart HydroStat will prevent burner operation during this condition. **IMPORTANT:** The system must be checked by a qualified heating professional prior to resuming operation. **WARNING: DO NOT ADD WATER UNTIL THE BOILER HAS FULLY COOLED.**

⑤ **ECONOMY ACTIVE** Indicates that the Thermal Targeting function is active and the Fuel Smart HydroStat will reduce boiler temperature to conserve fuel. The Economy feature is activated using the ECONOMY dial. (See “How Thermal Targeting Works” on page 4 for more information).

⑥ **ECONOMY TARGET** When the Economy feature is active, the Fuel Smart HydroStat continually sets target temperatures below the high limit setting to maximize fuel efficiency. When the

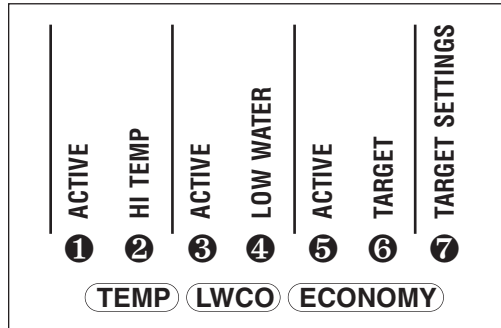

boiler water reaches the target temperature, the LED illuminates and the burner will shut down. The boiler water will continue to circulate and heat the house as long as the thermostat call continues. The LED will stay lit until the boiler temperature drops to the differential set point (see Target Temp Differential on page 4) at which point the boiler will be allowed to fire again. NOTE: This LED illuminates regularly during normal boiler operation.

⑦ TEST/SETTINGS Button

To Test Low Water Cut-Off: Press and hold the Test/Settings button for 5 seconds. The display will read LCO.

LWCO TEST LCO

The red Low Water light should illuminate and the burner circuit (B1 and B2) should de-energize. NOTE: The control must be installed with a Hydrolevel Electro-Well for low water cut-off functionality (see page 2 for more details).

To View Current Settings: Press and release the Test/Settings Button in short intervals to sequentially display the following settings:

- HIGH LIMIT SETTING HL
- ▼
- LOW LIMIT SETTING LL
- ▼
- ECONOMY SETTING ECO
- ▼
- CURRENT TARGET TEMPERATURE 000
- ▼
- PRE-PURGE SETTING PUR

The display will return to boiler temperature (default) if Test/Settings Button is not pressed for 5 seconds.

WATER PIPING

Always follow good piping practices. Observe minimum 1" clearance to combustibles around all uninsulated hot water pipes or when openings around pipes are not protected by non-combustible materials. On a hot water boiler installed above radiation level, the boiler must be provided with a low water cutoff device at the time of installation by the installer. (see Figure 17 for piping arrangement) For zoning and piping arrangement with indirect water heater, see figure 18 and 19.

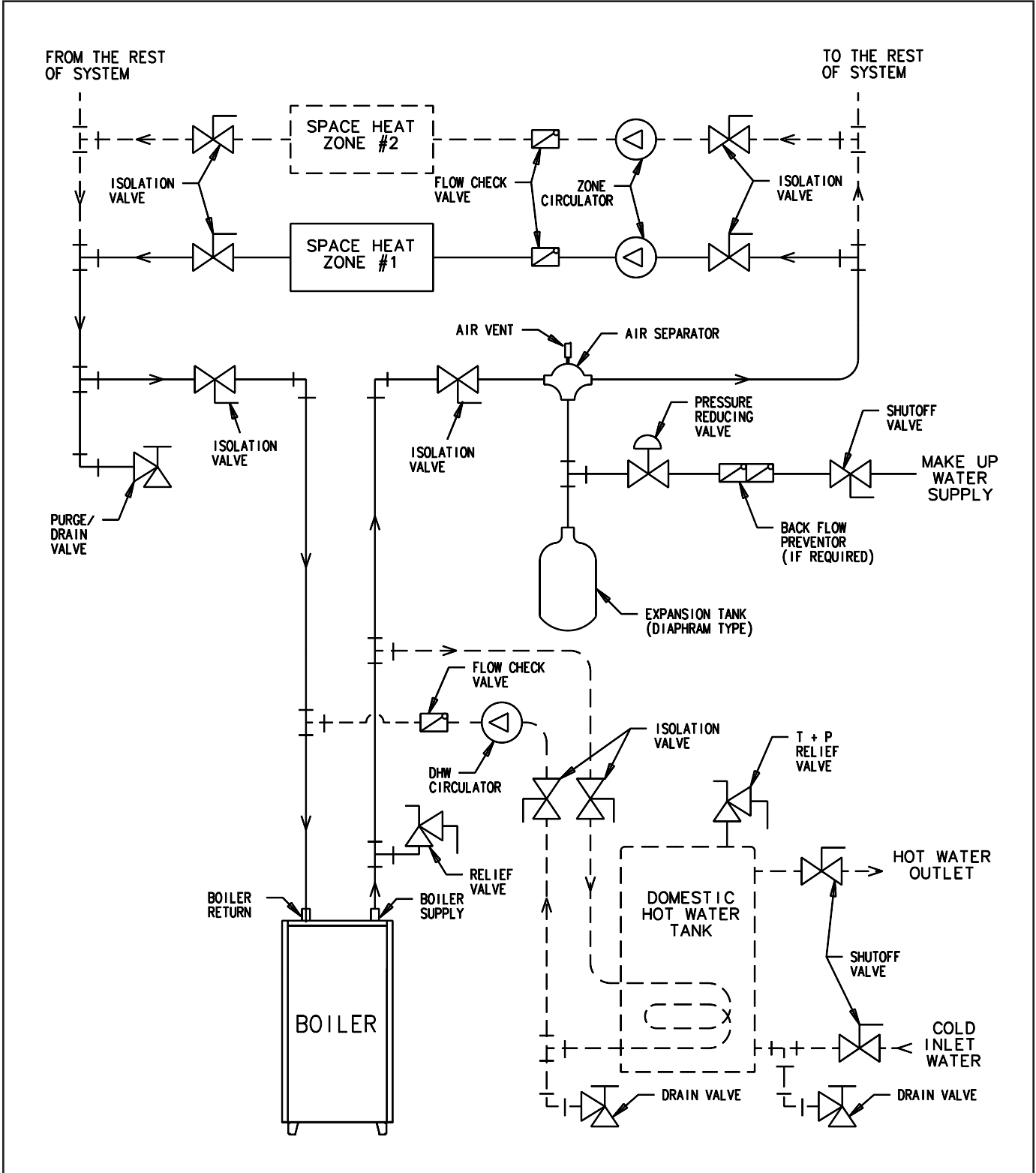

Figure 18. Zoning with circulators, optional indirect DHW tank

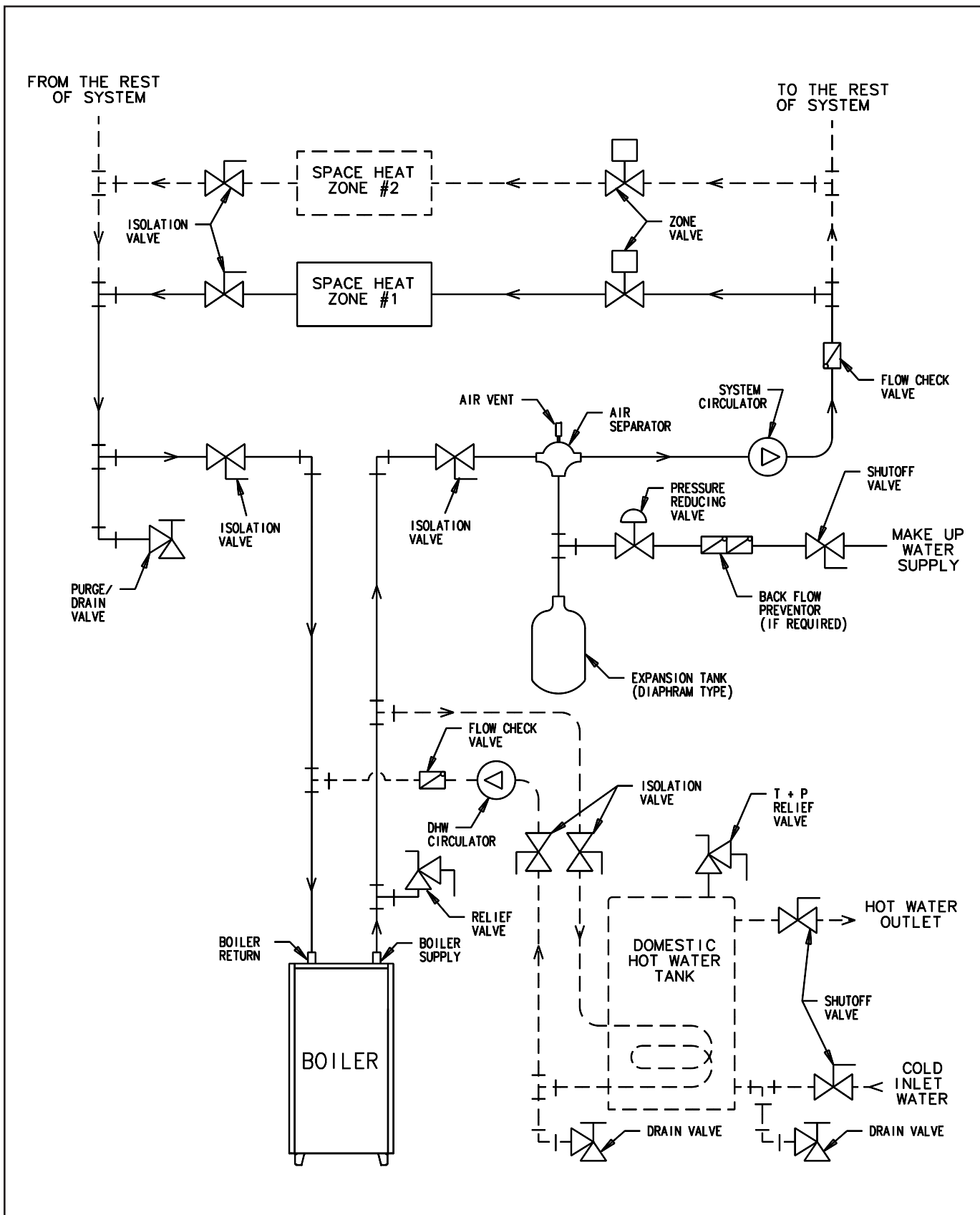

Figure 19. Zoning with zone valves, optional indirect DHW tank

1. Supply and Return

For tapping sizes see dimensions on page 2. Shut-off valves are recommended.

2. Circulating Systems

Victory II boilers are equipped with a water circulating pump mounted to the return water connection on the boiler. This pump location is appropriate for most installations. It may be desired and proper to locate this pump to the alternate pump location shown in Figure 17, especially when applied to larger systems using high-head pumps. When the pump is removed there is a 1 1/2" FPT tapping that the return pipe may be attached to.

3. Air Control System

Diaphragm type compression tank is used to control system pressure. It must be installed at the boiler or between boiler and supply main pump(s).

An automatic air vent is used to remove air from the system. It should be installed in the top of the boiler as shown in Figure 17. If system pressure needs further control, add an additional tank in parallel with original tank or install a larger capacity tank. Use appropriate size tank for volume of water in system. See chart for boiler's volume.

Boiler Water Content		
Model	Pounds	Gallons
VHS-30	17.5	2.1
VHS-60	24.75	3.0
VHS-90	32.00	3.8
VHS-120	39.25	4.7
VHS-150	46.50	5.6
VHS-180	53.75	6.4

4. Cold Water Fill

Pressure reducing (fill) valve and shut-off valve should be installed.

5. Relief Valve Discharge Piping

Use same size or larger piping than valve outlet. Must terminate 6" minimum from floor with a plain (no threads) end. Place a bucket under pressure relief valve discharge. Make sure discharge is always visible. DO NOT hard-pipe to drain piping.

6. Providing Protection from Freezing

Anti-freeze is sometimes used in hydronic heating systems to protect against freeze-up in the event of power failure or control shutdown when the building is unoccupied. It should be recognized that unless the building is kept above freezing temperature by some means, the plumbing system is not protected. Two types of anti-freeze may be used: ETHYLENE GLYCOL, used in automobiles, has desirable properties, but is toxic. Its use may be prohibited when system water/glycol solution is in contact with a potable water vessel (as an indirect hot water heater with built-in heating coils). PROPYLENE GLYCOL is used in the quick-freeze food industry; it is practically non-toxic. Its use may be permitted when system solution is in contact with a potable water vessel. When anti-freeze must be used, inhibited propylene glycol is recommended. Useful

information on the characteristics, mixing proportions, etc. of glycol in heating systems is given in Technical Topics No. 2A, available from the Hydronics Institute, 34 Russo Place, Berkeley Heights, NJ 07922. Consult glycol manufacturers for sources of propylene glycol.

7. Water Treatment

A good water treatment program will not only extend the useful life of this boiler but it will also save much of the time and expense of repairs made necessary by preventable occurrences. A reputable water treatment company should be consulted to evaluate and determine the best overall treatment program for your boiler equipment.

PIPING A HEATING - COOLING SYSTEM TO A WATER BOILER AND CHILLER

Figure 16 illustrates a method of piping a heating-cooling system to a water boiler and a chiller. Hand valves (shown) or automatic valves must be installed to prevent circulation of chilled water in the boiler or hot water in the chiller.

The air control system and pressure control system must operate with chiller only, or the boiler only, being valved to the piping system. Separate control devices on the boiler and chiller may be used, or a single set of air and pressure controls on the common piping may be preferred.

If the boiler is used to supply hot water to heating coils in air handling units, flow control valves or other devices must be installed to prevent gravity circulation of water in the coils during the cooling cycle.

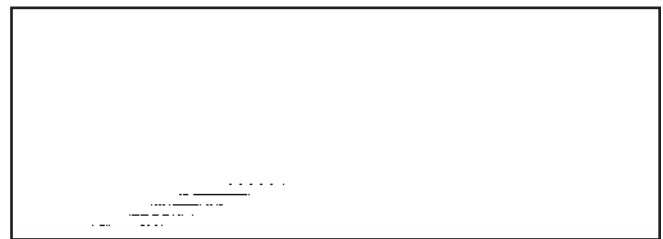

Figure 20.

OPERATING INSTRUCTIONS, BASIC

1. Filling and Venting Water Systems

- A. Fill the system with water. Vent or purge of air.
- B. Fire the boiler as soon as possible (see following warning and instructions) and bring water temperature in the system.
- C. Vent air and add water as needed to achieve operating pressure on boiler gauge. Pressure must be between approximately 12 psi (cold water) and 25 psi at water temperature setting of high limit control, for boilers equipped with 30 psi relief valves. Boilers rated for a higher pressure and equipped with a matching relief valve may operate at a higher pressure, but no higher than 5 psi below the relief valve opening pressure.
- D. Check for and repair any leaks before placing system in service.

BEFORE FIRING BOILER, make these checks:

1. System is full of water. Air is vented or purged.
2. Relief valve is installed in accordance with ASME Boiler and Pressure Vessel Code, Section IV. Valve opening is not closed or reduced in size.
3. Venting is installed according to instructions under "FLUE GAS VENTING REQUIREMENTS".
4. All wiring is completed, following applicable wiring diagrams.
5. Using soap solution, check for gas leaks in all gas piping from meter to boiler pilot and manifold. DO NOT use open flame.

2. Initial Start

Safe lighting and other performance criteria were met when testing various gas manifold and control assemblies used on the Victory II Series Boilers under the ANSI Z21.13- latest edition.

Instructions

Follow the lighting instructions in this manual. These instructions are also attached to the boiler.

SAFETY INFORMATION

For Your Safety Read Before Operating

WARNING: If you do not follow these instructions exactly, a fire or explosion may result causing property damage, personal injury or loss of life.

- A. This appliance is equipped with an ignition device which automatically lights the pilot. DO NOT try to light the pilot by hand.
- B. BEFORE OPERATING smell all around the appliance area for gas. Be sure to smell next to the floor because some gas is heavier than air and will settle on the floor.

WHAT TO DO IF YOU SMELL GAS:

- DO NOT try to light any appliance.
 - DO NOT touch any electric switch: DO NOT use any phone in your building.
 - Immediately call you gas supplier from a neighbor's phone. Follow the gas supplier's instructions.
 - If you cannot reach your gas supplier, call the fire department.
- C. DO NOT use this appliance if any part has been under- water. Immediately call a qualified service technician to inspect the appliance and to replace any part of the control system and any gas control which has been underwater.

OPERATING INSTRUCTIONS

1. **STOP!** Read the safety information above on this page.
2. Set the thermostat to lowest setting.
3. Turn off all electric power to the appliance.
4. This appliance is equipped with an ignition device which automatically lights the pilot. DO NOT try to light the pilot by hand.
5. Turn gas control knob clockwise ↻ to "OFF". DO NOT force.
6. Wait five (5) minutes (longer for propane) to clear out any gas. Then smell for gas, including near the floor. If you smell gas, **STOP!** Follow "B" in the safety information above on this page. If you don't smell gas, go to next step.
7. Turn gas control knob counterclockwise ↻ to "ON".
8. Turn on all electric power to the appliance.
9. Set thermostat to desired setting.
10. If appliance will not operate, follow the instructions "To Turn Off Gas To Appliance" and call your service or gas supplier.

To Turn Off Gas to Appliance

1. Set thermostat to lowest setting.
2. Turn off all electric power to the appliance if service is to be performed.
3. Turn gas control knob clockwise ↻ to OFF. DO NOT force.

3. Burner Adjustment

- A. Adjust gas input rate:
 1. Consult gas supplier for higher heating value* of gas (Btu/cu. ft.).
 2. Set thermostat high enough so that boiler will remain on while checking rate.
 3. Measure manifold pressure at 1/8" tapping. Correct manifold pressure for gas used is printed on boiler rating plate. NOTE: Gas pressure may be adjusted by turning pressure regulator screw on combination gas valve (turn clockwise to increase pressure, counterclockwise to decrease pressure).
 - a. Input for PROPANE is approximately at rating shown on rating plate when manifold pressure is 9 1/2" water column.
 - b. Input for NATURAL GAS is approximately at rating when manifold pressure is 3 1/2" water column, but should be checked on the gas meter: Btuh Input = Btu/cu. ft. x cu. ft. metered in 3 minutes x 20

Example 1:

For 1000 Btu/cu. ft. gas, this becomes:
 Btuh Input = cu. ft. metered in 3 minutes
 x 1000 Btu/cu. ft. x 20

Example 2:

For 1050 Btu/cu. ft. gas, this becomes:
 Btuh Input = cu. ft. metered in 3 minutes
 x 1050 Btu/cu. ft. x 20

4. The higher heating value* of gas varies substantially for different localities. Consult with Slant/Fin's Technical Service Dept. for re-orificing procedures if any of the following apply:
 - a. Boiler (burner) is overfiring. **CAUTION!** National Fuel Gas Code (ANSI Z223.1-latest edition) does NOT permit firing at a higher input rate than the input rate indicated on the boiler rating plate in order to avoid hazardous conditions such as explosion or carbon monoxide poisoning.
 - b. Poor higher* heating value of gas is causing the actual input to be substantially lower than the rating plate indication.

* "Higher heating" value of gas is commonly known as "heating value".

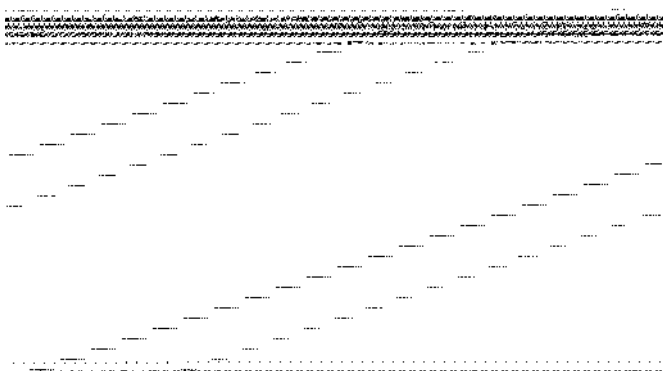

Figure 21.

Gas Rate Table

Boiler rated input in cu. ft./hr. of 1000 Btu/cu. ft. Natural Gas	Cubic Feet Gas Consumption 1000 Btu/cu. ft. gas, in 3 minutes, at rated input
30	1.50
60	3.00
90	4.50
120	6.00
150	7.50
180	9.00

The gas metered in 3 minutes to obtain rated input for each boiler model, using 1000 Btu/cu. ft. gas, is tabulated in gas rate table.

B. Main Burners

1. Fire the boiler continuously for at least 15 minutes, to reach burner operating temperature.
2. Observe the flames, all burners. The base of all flame jets should be blue. The tips should be blue shading to orange. NOTE: Dust, disturbed by any movement, will cause bright orange flames. Wait for dust to settle.
3. For one burner, close the air shutter until some of its flame jet tips turn yellow-white, indicating insufficient primary air. Then open shutter until whitish tips disappear completely. Set all burner shutters to the same opening. Observe to make sure that no yellow-white tips appear over any portion of the flame. Small yellow tips at the pilot are permitted (see Figure 22).

NOTE: This adjustment method gives MINIMUM primary air setting for safe combustion. DO NOT attempt to make this adjustment unless burners are at operating temperature. Adjustment should be made with burner access panel in final operating position. Use of a mirror may be helpful to observe flames. Note that burner ports are on top of main burner tube.

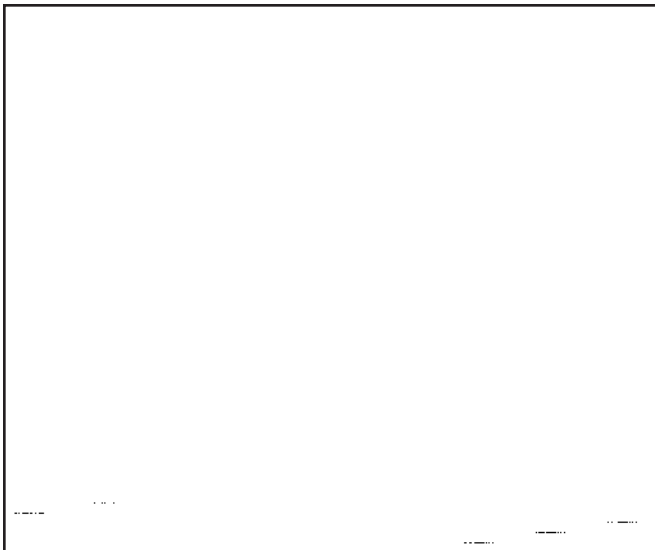

Figure 22.

C. Main Burner Ignition Checkout and Pilot Adjustment

1. The pilot flame must not smother or snuff out when tested as follows:
 - a. Main burner ignition from cold start-repeat.
 - b. Continued operation of main burner.
 - c. Main burner ignition with appliance at maximum operating temperature after prolonged operation.

NOTE: Observe operation of the pilot burner with appliance doors in the final operating position. Use of a mirror may be helpful.

2. Pilot Burner Adjustment

The pilot flame should envelope approximately 3/8 to 1/2 inch of sensor tip (see Figure 23). To adjust pilot flame:

- a. Remove the pilot adjustment cover screw from the gas control.
- b. Turn pilot adjustment screw clockwise to decrease or counterclockwise to increase pilot flame.
- c. Replace pilot adjustment cover screw.

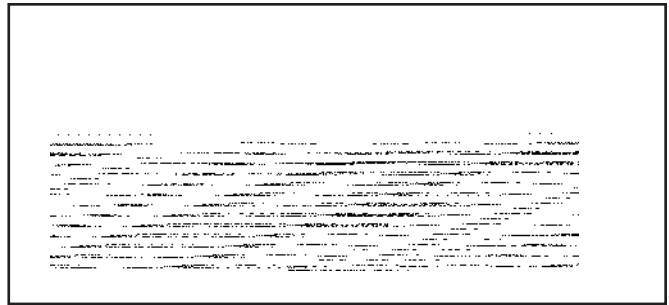

Figure 23.

SAFETY CHECK

Removing Control Box (cover). See Figure 24.

To remove control box:

- a. Turn black screw 1/4 turn clockwise to open position.
- b. Remove two sheet metal screws in the top of control box.
- c. Remove control box.

To replace the box, reverse procedure. Be sure that black screw is in the lower bracket receptacle and lock position.

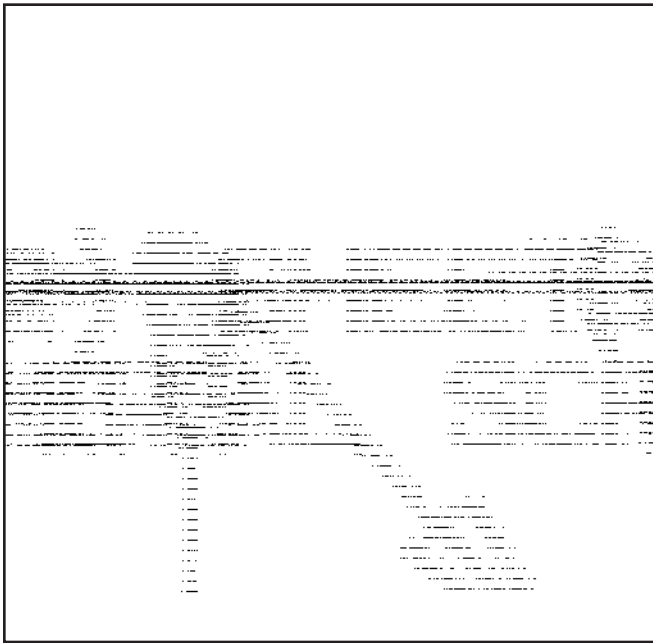

Figure 24.

1. High Limit Control Test

Set thermostat high enough for water temperature to reach high limit control setting of water temperature control. When this temperature is reached, the high limit switch should open and the main gas valve should close automatically.

2. Gas Control Safety Shutdown Test

With main burners firing, disconnect the ignition cable from S8600 ignitor (see Figure 21). Gas valve should shut off the main burners. If gas valve fails to shut off the main burners, replace the gas valve.

3. Air Flow Pressure Switch Test

With main burners firing, remove plastic hose from Pressure Switch (see Figure 26). Gas valve should shut off the main burners.



Figure 25.

WARNING: If any of the above controls fail to operate properly, they must be replaced.

4. Checking for Gas Leaks

Using soap solution, check for gas leaks from meter to burner, including gas valve, gas piping, manifold and pilot burner.
DO NOT use open flame.

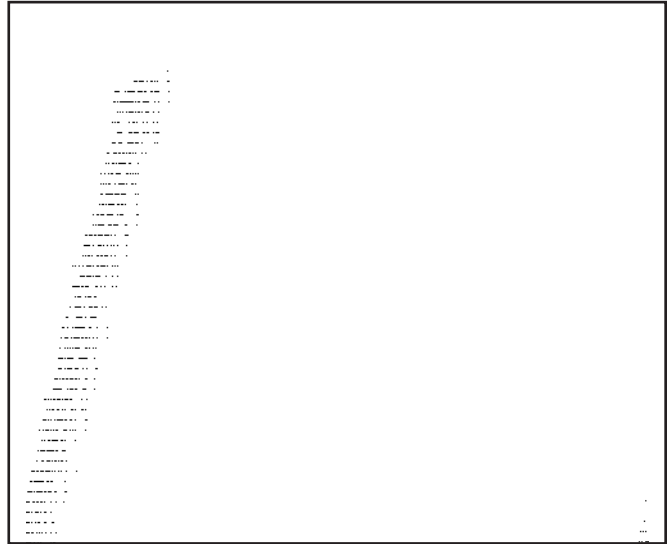

Figure 26.

CARE AND MAINTENANCE

This section must be brought to the attention of the owner by the installer so that the owner can make the necessary arrangements with a qualified service agency for the periodic care and maintenance of the boiler. The installer must inform the owner that the gas supplier can recommend a number of qualified service agencies. The installer must also inform the owner that the lack of proper care and maintenance of this boiler and any fuel burning equipment may result in a hazardous condition. Installer should discuss contents of the User's Information Manual (Publication VHS-UIM) with the owner.

A trained and qualified service technician should perform the inspections listed in these instructions before each heating season and at regular intervals.

1. General Maintenance

- A. Boiler control check. See "Safety Check" on Page 28.
- B. Venting system inspection
 - 1. Check for obstructions, condensation, corrosion and physical damage.
 - 2. Perform "Venting System Regular Inspection" on Page 14.
 - 3. If the boiler is vented horizontally through the wall, the outside termination and screen should be checked for any debris blocking the opening and cleared as a required.

C. Piping

Check the following:

1. Water piping and accessories for leaks. Slightest leaks should be corrected.
2. System to be full of water and pressure to remain stable at correct setting on gauge.
3. Air-control system. Noise and air binding in radiation should not occur.
4. Low water cutoff for operation (see instructions furnished with unit).

D. Boiler Room Air Supply

Check air vents for continued positive supply of air as required. Air needs are greatest in cold weather. Air vents must be open and free of obstruction.

WARNING: *The flow of combustion and ventilating air to the boiler should not be obstructed.*

2. Inspection During Heating Season

- A. Check water pressure regularly and add water slowly to system when needed. If much water is added, venting may be necessary. Regular loss of water from boiler system may indicate either a system leak, or a faulty air control system, or a faulty automatic fill valve.
- B. Check venting system. See "Venting System Regular Inspection" on Page 14.
- C. Check condensation drain trap to be full of water. Check for deterioration of the tubing. Check that the trap is not plugged.

3. Annual Inspection and Cleaning

The following must be done by a competent serviceperson to help insure safe and reliable operation:

A. Flue passage cleaning

See Figure 27. It is suggested that paper be placed on burners to collect any foreign material in cleaning flues.

1. Remove control box (see instruction under "Safety Check". See Figure 24).
2. Remove jacket top.
3. Remove inducer assembly.
4. Remove flue collector.
5. Use wire brush to clean flue passages.
6. Replace flue collector and re-seal with furnace cement.
7. Replace inducer assembly, jacket top and control box.
8. Remove and dispose of paper and accumulated material.

WARNING:

The ceramic combustion chamber in the burner box contains crystalline silica.

Wear proper dust mask and gloves when servicing combustion chamber or burners.

Crystalline Silica has been identified as a carcinogen or possibly carcinogenic to humans.

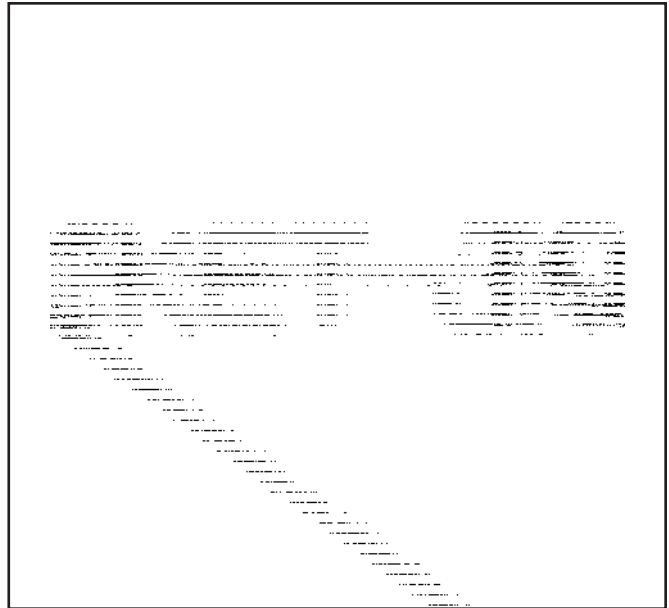

Figure 27.

B. Cleaning of burners

If burners' surfaces are not clean, or uneven flame indicates plugged burner parts, remove and clean burners.

1. Remove pilot gas line at gas valve.
2. Disconnect pilot burner assembly from pilot bracket.
3. Lift burner and remove burner from orifice.
4. Clean burners. To clean burners, run a clean flue brush up the tube until all foreign matter is removed.
5. Replace burners, pilot assembly, ignitor and sensor wires.
6. Adjust burners and pilot assembly.

C. Re-check of input gas rate of burners. See "Burner Adjustment" on Page 27.

D. Re-adjusting for best flame characteristics of main flame and pilot burner flame. See "Burner Adjustment" on Page 27.

E. To prolong the life of inducer motor, lubricate with Anderol 465 or SAE 20 motor oil annually. Turn off power and place 4-6 drops of above mentioned lubricate in each of two oil holes. Lubricate circulator per manufacturer's instruction. DO NOT over oil any motor.

Victory II Boiler Sequence of Operations

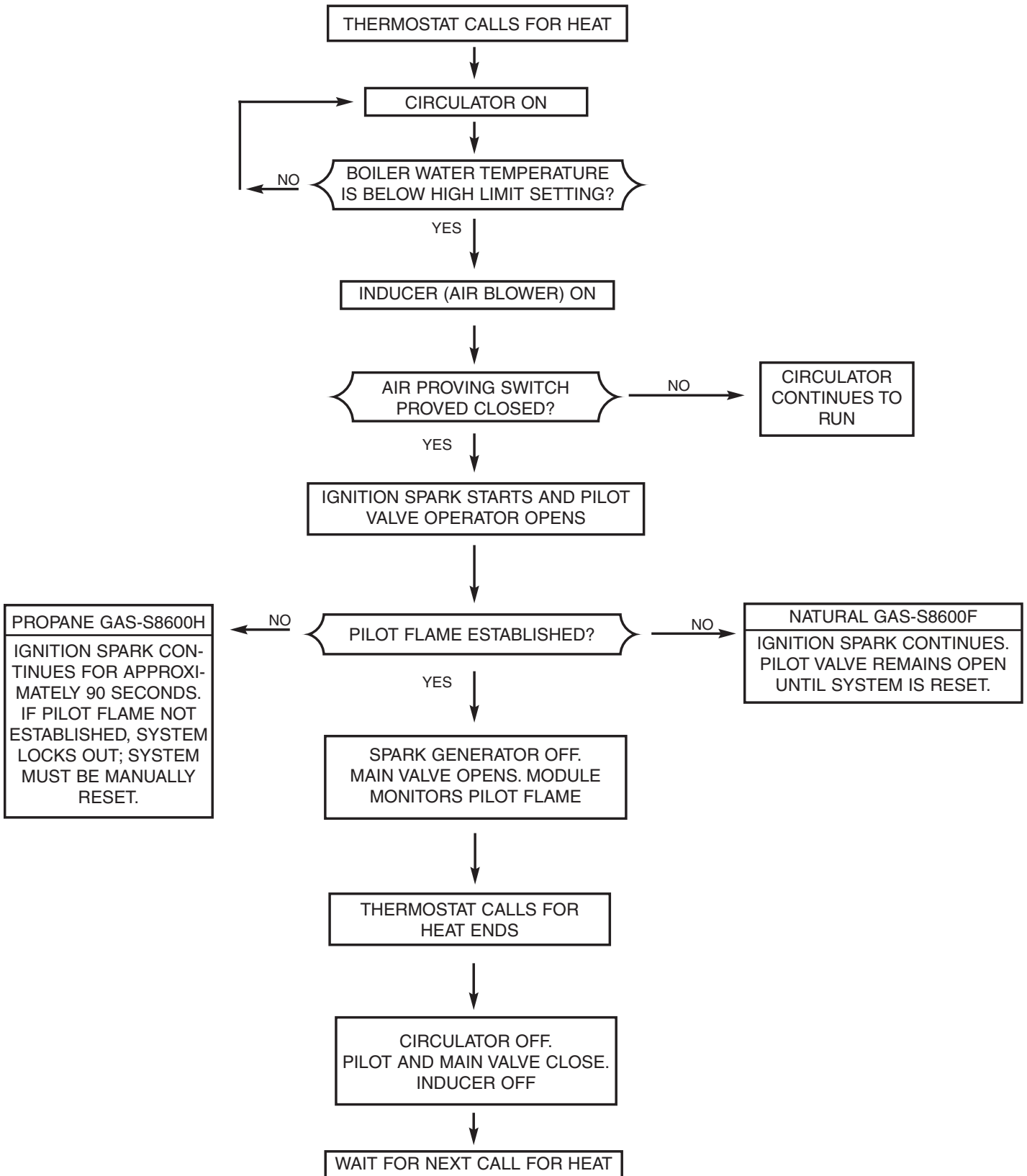

General Troubleshooting Guide For Service people

BURNERS FAIL TO OPERATE

CAUSE

1. Gas supply valve shut off
2. No power, main electric switch open
3. No power, blown or defective line fuse
4. Pilot flame too low
5. Flame sensor contaminated
6. Roll-out switch open

7. Defective air flow switch, restriction or obstruction in venting system
8. Defective blower motor

9. Defective transformer
10. Defective gas valve

REMEDY

1. Open gas valve
2. Close switch
3. Replace fuse
4. Adjust pilot flame
5. Clean sensor
6. Replace roll-out switch (inspect flue passages prior to replacement)
7. Check air flow switch hose connections. Check for obstruction or restriction in venting system. Replace defective switch
8. Check voltage (120V) at motor connector. Replace defective motor
9. Replace Aquastat
10. Replace

BURNERS WILL NOT SHUT-OFF

CAUSE

1. Defective boiler control
2. Improper wiring or short circuit

REMEDY

1. Replace defective boiler control
2. Check wiring

FLASH BACK-BURNING AT ORIFICES

CAUSE

1. Manifold gas pressure too low
2. Improper primary air adjustment
3. Gas regulator bleed too slow
4. Burrs on orifices
5. Improper orifice
6. Adverse draft condition in boiler room
7. Low main gas pressure

REMEDY

1. Adjust to proper manifold pressure
2. Adjust air to produce soft, clean flame
3. Adjust bleed opening
4. Remove burrs
5. Install proper orifice size
6. Check air supply and venting system
7. Contact utility

DELAYED IGNITION

CAUSE

1. Pilot flame too low
2. Excessive primary air
3. Excessive burner input

REMEDY

1. Adjust pilot flame
2. Adjust primary air shutter
3. Check and reduce to input shown on rating plate

NOT ENOUGH HEAT

CAUSE

1. Thermostat setting is too low
2. Boiler water maintained at too low temperature
3. Circulator not running

4. Boiler water level too low

REMEDY

1. Set thermostat at higher setting
2. Set boiler control at higher setting
3. With thermostat calling for heat, check for power to circulator. If power OK but circulator not running, replace circulator
4. Carefully snap open relief valve handle to determine if boiler is full of water. If not full of water, check for system leaks and check water pressure regulator. Repair any system leaks. Adjust or replace water pressure reducing valve

FUMES AND GAS ODORS

CAUSE

1. Leaks in gas piping or accessories
2. Gas leaks in service line or meter connections
3. Adverse draft condition in boiler room
4. Condensation trap is not full of water
5. Venting system is physically damaged

6. Over-firing

REMEDY

1. Locate leaks and repair
2. Close service supply valve - shut down boiler and notify utility
3. Check air supply and venting system
4. Check and fill with water
5. Check carefully and repair. Also, see "Venting System Regular Inspection"
6. Adjust gas input to that shown on boiler rating plate

BURNER SHORT CYCLES

CAUSE

1. Thermostat heat anticipator set too low
2. Excessive pressure drop due to excess venting system
3. Blockage or restriction in venting system
4. Defective air flow switch (out of adjustment)

REMEDY

1. Reset anticipator
2. Venting system must be corrected
3. Check and repair
4. **DO NOT** adjust, replace

IF REPLACEMENT PARTS ARE NEEDED

When parts are needed, refer to boiler model and serial number shown on the boiler name/rating plate. Refer to publication number VHS-11PL Victory II replacement parts for part numbers. Whenever possible refer to the original order by number and date.

Control identification and replacement should not be attempted by unskilled personnel. Only simple,

easily-identified controls and parts may be obtained locally. All other controls and parts should be identified by and ordered from Slant/Fin. Relief/Safety valves must be ASME rated for the pressure and gross output of the boiler.

For replacement parts, heating contractors should contact their Slant/Fin boiler distributor.

APPENDIX A
Vent System Location and Condensation
Drain Requirements

1. The venting system shall terminate at least 3 feet above any forced air inlet located within 10 feet.
2. The venting system shall terminate at least 4 feet below, 4 feet horizontally from, or 1 foot above any door, window or gravity air inlet into any building. The bottom of the vent terminal shall be at least 12 inches above grade or the normal snow level, whichever is greater.
3. Through the wall vents for Category II and IV appliances shall not terminate over public walkways or over areas where condensate or vapor could create a nuisance or hazard or could be detrimental to the operation of regulators, relief valves or other equipment. Minimum clearance of 4' horizontally from, and in no case above or below, unless a 4' horizontal distance is maintained, from electric meters, gas meters, regulators and relief equipment. Where local experience indicates that condensate may be a problem with Category I and III appliances, this provision shall also apply.
4. Provision shall be made to collect and dispose of condensate from venting systems serving Category I, II, III and IV appliances.

Caution

Flue gases exiting from the vent terminal will condense. Building materials in the area of the vent terminal should be protected from discoloration and degradation.

APPENDIX B
Removal of Existing Boiler From
Common Vent System

- a. Seal any unused openings in the common venting system.
- b. Visually inspect the venting system for proper size and horizontal pitch and determine there is no blockage or restriction, leakage, corrosion and other deficiencies which could cause an unsafe condition.
- c. Insofar as is practical, close all building doors and windows and all doors between the space in which the appliances remaining connected to the common venting system are located and other spaces of the building. Turn on clothes dryer and any appliance not connected to the common venting system. Turn on any exhaust fans, such as range hoods and bathroom exhausts, so they will operate at maximum speed. DO NOT operate a summer exhaust fan. Close fireplace dampers.
- d. Place in operation the appliance being inspected. Follow the lighting instructions. Adjust thermostat so appliance will operate continuously.
- e. Test for spillage at the draft hood relief opening after 5 minutes of main burner operation. Use the flame of a match or candle, or smoke from a cigarette, cigar or pipe.
- f. After it has been determined that each appliance remaining connected to the common venting system properly vents when tested as outlined above, return doors, windows, exhaust fans, fireplace dampers and any other gas burning appliance to their previous conditions of use.
- g. Any improper operation of the common venting system should be corrected so the installation conforms with the National Fuel Gas Code, ANSI Z223.1-latest edition. When resizing any portion of the common venting system, the common venting system should be resized to approach the minimum size as determined using the appropriate tables in Appendix G in the National Fuel Gas Code, ANSI Z223.1-latest edition.



©Slant/Fin Corp. 2013. Printed in the U.S.A. 1013. Publication No. VHS-41. P/N 44-0849

SLANT/FIN CORPORATION, Greenvale, N.Y. 11548 • Phone: (516) 484-2600
FAX: (516) 484-5921 • Canada: *Slant/Fin LTD/LTEE, Mississauga, Ontario*

www.slantfin.com