

# ULTRA-ZONE™

Residential Steam Humidifier System

## MODEL S2000 & S2020

### The Worlds Most Efficient Humidifier Just Got Better!



Included

#### Optional Accessories



APD Closed



APD Open



WFA 195

- Computer Watchdog Circuit
- Automatic Drain/Flush system
- Highest efficiency rating
- Automatic maintenance mode
- Replaceable Sacrificial Anode
- 100% guaranteed no summer maintenance
- Humidifies without a call for heat

- LED's for system readout
- Most effective cure for dry homes
- Listed and Approved by UL
- Interlocking wiring for fan control
- Compatible with all forced air systems
- New Feature - Current sensing relay that provides fan proving for safety.
- Optional Water Filter

Excellence Without Compromise

# EWC®

CONTROLS INC.

Proudly Made in the USA for over 40 Years



# S2000 & S2020

## Residential Steam Humidifier System

The most technologically advanced humidifier has become better with the help of a computer. The S2000 and S2020 Steam Humidifiers have a built-in computer chip to insure efficiency, accuracy, reliability and safety.

The automatic flush system will drain the humidifier every (8) eight hours of operation. This is a preventative maintenance mode to help insure maximum unit efficiency. The humidifier will completely empty itself and not refill until another call for humidity. This mode insures that all summer long, when the humidifier is not in operation the unit will not be full of water.

The LED read-out display on the front cover shows the proper operation of the unit. The display also shows the installer and homeowner the effectiveness and the reliability of the unit.

The only humidifier that will operate in the heating system without a need for a heat call. The steam humidifier, model S2000 and S2020 will operate and turn the fan on independently of the furnace. The ultimate operation for maximum homeowner comfort.

The UL label enforces EWC's commitment to product reliability and safety. Underwriters Laboratories (UL) is an independent auditing agency that rigorously tests the performance of electrical devices. Their seal is a symbol of excellence.

The S2000 and S2020 are compatible with all makes and models of forced air heating units. The steam humidifier is the only humidifier that will work to its maximum capacity on heat pump systems.

The replaceable Sacrificial Anode helps reduce the mineral and calcium deposits in the water from settling on the element or tank. This process helps prolong the life of the unit.

The optional current sensing relay (model APD) provides additional protection for the S2000 / S2020. The split core design allows easy installation of an air proving switch to ensure the S2000 / S2020 only energizes during fan operation.

The optional water filter (Model WFA-195) allows greater protection from mineral and calcium infiltration.

### Specifications

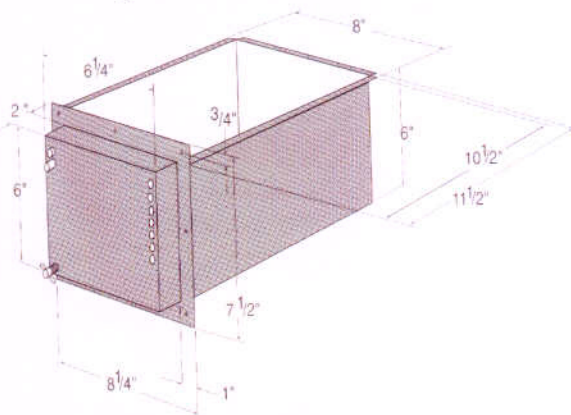

S2000	
Output Capacity	16 gal/day
Square Footage	2,800 sq. ft.
Voltage	120
Electrical	1.4 KW, 15 amps
Plenum Opening	6"x6"
Weight	9 lbs.
Humidistat Included	
S2020	
Output Capacity	22 gal/day
Square Footage	3,500 sq. ft.
Voltage	220 VAC
Electrical	2.0 KW, 10 amps
Plenum Opening	6"x6"
Weight	9 lbs.
Humidistat Included	

*Engineering assistance only a phone call away*

Excellence Without Compromise  
**EWC**  
 CONTROLS INC.

**ULTRA-ZONE™**  
 COMFORT CONTROL SYSTEMS

385 Highway 33 Englishtown, NJ 07726

Telephone: 800-446-3110

Fax: 732-446-5362

www.ewccontrols.com

© copyright 2006 EWC Controls

Form S2000