



TRANE™

Split System Heat Pump Product Data

XE 1100

TWN018-060C

1½ – 5 Ton



PUB. NO. 22-1633-04-1296 (EN)



General Features

Split System Heat Pump Units . . . Designed With Your Needs In Mind.

TWN split systems represent a new approach to designing products for The Trane Company. The design team's mission is ". . . to bring a system to the marketplace that will meet your job requirements every time" . . . And at a competitive price.

Trane's experienced design team used the newest computer technology and an entirely new manufacturing process to develop a new standard in split systems. Couple the Trane reputation for quality and reliability in split system heat pumps with improvements in efficiency, flexibility and installation ease . . . and you have systems that prove "It's Hard to Stop a Trane."

Manufacturing Control

Trane's exclusive control over the design and manufacturing of all major components is unique in the industry. This approach assures us total control over both the quality and reliability of these components. It also allows us to custom match components to deliver the best in split system performance.

Designing the Details

Careful attention was given to designing the details — from control wiring to the access panels. Trane units feature time-saving colored wiring and removable panels which allow complete access to all major components and controls. All outdoor units feature external high and low pressure gauge ports for easy diagnosing and servicing of the unit.

UL Listed and CSA Certified

Trane meets or exceeds all nationally recognized agency safety and design standards. Each unit is UL designed, approved, and labeled in accordance to UL Standards: UL 1995, including approval for use in Canada. Each unit is rated in accordance with ARI Standard 210/240 and 270.

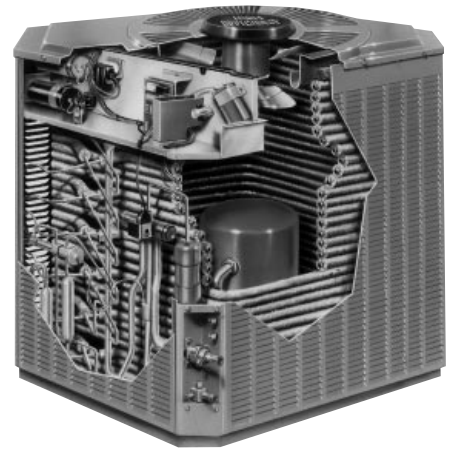

Contents

Feature Summary	2
Features and Benefits Optional Equipment Low Outdoor Ambient Cooling Standard Capacity Rating Conditions	4
Selection Procedure Model Number Nomenclature	6
General Data TWN018C100B TWN024C100A TWN030C100A TWN036C100B TWN042C100A TWN048C100A TWN060C100A	7
Ratings With Auxiliary Devices	24
Electrical Data	28
Dimensions	30
Mechanical Specification Options	31



Features and Benefits

- High efficiency Trane Climatuff® compressor
- Spine Fin™ aluminum outdoor coil
- Solid state electronic defrost control
- Brazed refrigerant connections
- Multi-use service valves
- Steel cabinet, full coil protection
- Powder paint covers uniformly to resist rust & corrosion
- Attractive silver gray color
- Top cover/motor mount/grille combined
- Fast draining base pan assembly
- Compressor crankcase heat provided
- Liquid line filter-drier
- Single side service access
- Low ambient cooling to 40°F. with accessory AY28X084
- Factory installed start kit
- **5-year limited warranty on compressor & coil, 1 year on parts**
- **Optional extended compressor warranty**



Features and Benefits

OPTIONAL EQUIPMENT

OPTIONAL EQUIPMENT FOR CONDENSING UNITS (Check mark [✓] indicates accessories included).

Indoor Thermostats — XT 501 Automatic Programmable Thermostat	TAYSTAT501 []
XT 500 Electric Setback Thermostat	TAYSTAT500 []
Programable Thermostat	BAYSTAT038A []
Remote Temperature Sensor	BAYSENS025A []
Automatic Changeover Thermostat	BAY28X138 []
Manual Changeover Thermostat	BAYSTAT239 []
Manual Changeover Thermostat	BAYSTAT240 []
Outdoor Thermostats	TAYSTAT250A []
Evaporator Defrost Control Kit permits cooling to 40°F outdoor temperature	AY28X084 []
Indoor Fan Delay Relay Kit	BAY24X045 []
Line Insulation Kit	BAYINS001 []
5-7 Minute Delay Relay ^①	BAY41X171A []
Snow Legs	BAYLEGS001A []
Isolators (4)	BAYISLT100 []
Thermostat Cover ^②	BAY28X190 []

- ① Do not use with programmable thermostats
- ② Not used with programmable thermostat

BRAZED TUBING REFRIGERANT LINE SETS (All Suction Lines are Insulated.)

3/4" ODM (90° bend, one end), 3/4" and 5/16" tubing	TAYREFLN2__* []
7/8" ODM (90° bend, one end), 7/8" and 3/8" tubing	TAYREFLN3__* []
1-1/8" ODM (90° bend, one end), 1-1/8" and 3/8" tubing	TAYREFLN4__* []

*Line lengths: 15, 20, 25, 30, 40 & 50 ft. Insert desired line length in catalog number at right for the complete number.
Example: TAYREFLN220

LOW OUTDOOR AMBIENT COOLING

Low Ambient Cooling	As Manufactured	Evaporator Defrost Control
FCCV Accutron	55°F	40°F
Thermal Expansion Valve (TXV)	40°F	30°F

A.R.I. STANDARD CAPACITY RATING CONDITIONS

A.R.I. STANDARD 210/240 RATING CONDITIONS — (A) Cooling 80°F. D.B., 67°F. W.B. air entering indoor coil, 95°F. D.B. air entering outdoor coil. (B) High Temperature Heating 47°F. D.B., 43°F. W.B. air entering outdoor coil, 70°F. D.B. air entering indoor coil. (C) Low Temperature Heating 17°F. D.B., 15°F. W.B. air entering outdoor coil, 70°F. D.B. air entering indoor coil. (D) Rated indoor airflow for heating is the same as for cooling.

A.R.I. STANDARD 270 RATING CONDITIONS — (Noise rating numbers are determined with the unit in cooling operation.) Standard Noise Rating number is at 95°F. outdoor air.



Selection Procedure

Model Number Nomenclature

1 2 3 4 5 6 7 8 9 10 11
T W N 0 4 2 C 1 0 0 A

PRODUCT TYPE

Split Cooling - TTA, TTN, TTR, TTX, TTY
 Split Heat Pump -
 TWA, TWN, TWR, TWX, TWY
 Package Cooling -
 TCC, TCH, TCD, TCX, TCM, TCY
 Package Heat Pump - WCC, WCD, WCH,
 WCM, WCX, WCY, DCY, DCX
 Air Handler - TWV, TWH, TWB, TWE
 Gas/Electric - YCC, YCD, YCH, YCX, YCY
 Coils - TXA, TXC, TXE, TXF

MINOR DESIGN MODIFICATION

SECONDARY FUNCTIONS

Gas/Electric - Gas Heating
 Furnaces - Cooling Airflow
 Air Handlers - Flow Control

SPLIT SYSTEM COUPLING SYSTEMS

1 - 5 TONS
 0 - Brazed

POWER SUPPLY & FUEL

PRIMARY CAPACITY

Example: 042 = 42 MBTUH = 3½ Tons

MAJOR DESIGN MODIFICATION

General Data

TWN018C100B

OUTDOOR UNIT ^{①②}	TWN018C100B
NOISE RATING (DECIBELS) ^②	78
POWER CONNS. — V/PH/Hz	200/230/1/60
MIN. BRCH. CIR. AMPACITY ^③	11
BR. CIR. } MAX. (AMPS)	15
PROT. RTG. } RECMD. (AMPS)	15
COMPRESSOR	CLIMATUFF [®]
NO. USED - NO. SPEEDS	1 - 1
VOLTS/PH/Hz	200/230/1/60
R.L. AMPS - L.R. AMPS	8 - 45
BRCH. CIR. SELEC. CUR. AMPS	8.0
OUTDOOR FAN — TYPE	PROPELLER
DIA. (IN.) - NO. USED	18 - 1
TYPE DRIVE - NO. SPEEDS	DIRECT - 1
CFM @ 0.0 IN. W.G. ^④	1430
NO. MOTORS - HP	1 - 1/15
MOTOR SPEED R.P.M.	825
VOLTS/PH/Hz	200/230/1/60
FL. AMPS	0.50
OUTDOOR COIL — TYPE	SPINE FIN [™]
ROWS - F.P.I.	1 - 24
FACE AREA (SQ. FT.)	12.22
TUBE SIZE (IN.)	3/8
REFRIGERANT CONTROL	EXPANSION VALVE
REFRIGERANT	
LBS. — R-22 (O.D. UNIT) ^⑤	5-LBS., 10-OZ.
FACTORY SUPPLIED	YES
LINE SIZE - IN. O.D. GAS ^⑥	5/8
LINE SIZE - IN. O.D. LIQ. ^⑥	1/4
FCCV — RESTRICTOR ORIFICE SIZE	0.049
DIMENSIONS	H X W X D
OUTDOOR UNIT - CRATED (IN.)	25 X 30 X 26-1/2
UNCRATED	SEE OUTLINE DWG.
WEIGHT	
SHIPPING (LBS.)	159
NET (LBS.)	151

- ① CERTIFIED IN ACCORDANCE WITH A.R.I. STANDARD 210/240.
- ② RATED IN ACCORDANCE WITH A.R.I. STANDARD 270.



SPLIT SYSTEM

- ③ CALCULATED IN ACCORDANCE WITH NATL. ELECTRIC CODE. SUITABLE FOR USE WITH HACR CIRCUIT BREAKERS OR FUSES.
- ④ STANDARD AIR - DRY COIL - OUTDOOR
- ⑤ THIS VALUE APPROXIMATE. FOR MORE PRECISE VALUE SEE UNIT NAMEPLATE AND SERVICE INSTRUCTION.
- ⑥ MAX. LINEAR LENGTH 80 FT; MAX. LIFT - SUCTION 60 FT; MAX. LIFT - LIQUID 60 FT. MAX. LENGTH OF PRECHARGED TUBING 50 FT. FOR GREATER LENGTH REFER TO REFRIGERANT PIPING MANUAL PUB. NO. 32-3009.



OUTDOOR UNIT WITH HEAT PUMP COILS

	TXA024C4	TXA025C4	TXC024C4	TXC025C4	TXC031S3	TXH025A4
EXPANSION TYPE	CHG TO 49	CHG TO 49	CHG TO 49	CHG TO 49	TXV-NB	CHG TO 49
RATINGS (COOLING) ^①						
BTUH (TOTAL)	17400	17700	17400	17700	18400	17800
BTUH (SENSIBLE)	12100	13000	12100	13000	13800	12400
INDOOR AIRFLOW (CFM)	650	665	650	665	675	650
SYSTEM POWER (KW)	1.71	1.73	1.71	1.73	1.71	1.75
SEER (BTU/WATT-HR.)	10.50	10.55	10.50	10.55	11.90	10.90
RATINGS (HEATING) ^①						
(HIGH TEMP.) BTUH	16100	16500	16100	16500	16800	16500
SYSTEM POWER (KW)	1.58	1.54	1.58	1.54	1.45	1.55
COP	2.98	3.14	2.98	3.14	3.40	3.12
HSPF (BTU/WATT-HR.)	6.80	6.80	6.80	6.80	7.00	6.80

OUTDOOR UNIT WITH AIR HANDLERS

	TWE018C14	TWE018P13	TWE024P13	TWE030P13	TWE031E13	TWH018B14	TWH024B14
EXPANSION TYPE	FACT INS 49	TXV-NB	TXV-NB	TXV-NB	TXV-NB	FACT INS 49	CHG TO 49
RATINGS (COOLING) ^①							
BTUH (TOTAL)	17700	18100	18500	18000	18800	17800	18100
BTUH (SENSIBLE)	12000	12800	13700	13300	13700	12900	13800
INDOOR AIRFLOW (CFM)	600	600	675	675	650	600	675
SYSTEM POWER (KW)	1.66	1.71	1.72	1.71	1.59	1.70	1.71
SEER (BTU/WATT-HR.)	11.25	11.50	11.50	11.50	11.90	11.00	11.15
RATINGS (HEATING) ^①							
(HIGH TEMP.) BTUH	16100	16600	16800	16600	16300	16300	16500
SYSTEM POWER (KW)	1.51	1.49	1.48	1.55	1.36	1.52	1.50
COP	3.12	3.26	3.32	3.14	3.52	3.14	3.22
HSPF (BTU/WATT-HR.)	6.80	6.80	6.85	6.80	7.20	6.80	6.90

*See page 24 for combinations with Auxiliary Devices.



General Data

TWN018C100B

OUTDOOR UNIT WITH AIR HANDLERS

	TWV018B14	TWV024B14	TWV025B14
EXPANSION TYPE	FACT INS 49	CHG TO 49	CHG TO 49
RATINGS (COOLING) ①			
BTUH (TOTAL)	17500	18000	18100
BTUH (SENSIBLE)	12700	13700	13800
INDOOR AIRFLOW (CFM)	600	675	675
SYSTEM POWER (KW)	1.68	1.76	1.73
SEER (BTU/WATT-HR.)	11.00	11.00	11.00
RATINGS (HEATING) ①			
(HIGH TEMP.) BTUH	16600	16600	16500
SYSTEM POWER (KW)	1.50	1.55	1.52
COP	3.24	3.14	3.18
HSPF (BTU/WATT-HR.)	6.95	6.80	6.85

OUTDOOR UNIT WITH FURNACES & COILS

	TDD080R9V3 +TXC031E5	TDD080R9V3 +TXC031S3	TUD080R9V3 +TXC031E5	TUD080R9V3 +TXC031S3	TUY080R9V3A +TXC031E5	TUY080R9V3A +TXC031S3
EXPANSION TYPE	TXV-B	TXV-NB	TXV-B	TXV-NB	TXV-B	TXV-NB
RATINGS (COOLING) ①						
BTUH (TOTAL)	18900	18600	18800	18600	18800	18800
BTUH (SENSIBLE)	13600	13300	13500	13400	13400	13400
INDOOR AIRFLOW (CFM)	600	600	600	600	575	575
SYSTEM POWER (KW)	1.56	1.54	1.59	1.57	1.57	1.57
SEER (BTU/WATT-HR.)	11.90	11.90	11.80	11.90	11.90	11.90
RATINGS (HEATING) ①						
(HIGH TEMP.) BTUH	16300	16000	16400	16100	16300	16300
SYSTEM POWER (KW)	1.31	1.29	1.34	1.32	1.33	1.33
COP	3.64	3.64	3.58	3.58	3.58	3.58
HSPF (BTU/WATT-HR.)	7.35	7.35	7.25	7.25	7.30	7.30

*See page 24 for combinations with Auxiliary Devices.



General Data

TWN024C100A

OUTDOOR UNIT ①②	TWN024C100A
NOISE RATING (DECIBELS) ②	78
POWER CONNS. — V/PH/Hz	200/230/1/60
MIN. BRCH. CIR. AMPACITY ③	15
BR. CIR. } MAX. (AMPS)	25
PROT. RTG. } RECMD. (AMPS)	20
COMPRESSOR	CLIMATUFF®
NO. USED - NO. SPEEDS	1 - 1
VOLTS/PH/Hz	200/230/1/60
R.L. AMPS - L.R. AMPS	9 - 62
BRCH. CIR. SELEC. CUR. AMPS	11.0
OUTDOOR FAN — TYPE	PROPELLER
DIA. (IN.) - NO. USED	22 - 1
TYPE DRIVE - NO. SPEEDS	DIRECT - 1
CFM @ 0.0 IN. W.G. ④	2525
NO. MOTORS - HP	1 - 1/6
MOTOR SPEED R.P.M.	825
VOLTS/PH/Hz	200/230/1/60
FL. AMPS	0.90
OUTDOOR COIL — TYPE	SPINE FIN™
ROWS - F.P.I.	1 - 24
FACE AREA (SQ. FT.)	17.53
TUBE SIZE (IN.)	3/8
REFRIGERANT CONTROL	EXPANSION VALVE
REFRIGERANT	
LBS. — R-22 (O.D. UNIT) ⑤	6-LBS., 15-OZ.
FACTORY SUPPLIED	YES
LINE SIZE - IN. O.D. GAS ⑥	3/4
LINE SIZE - IN. O.D. LIQ. ⑥	5/16
FCCV — RESTRICTOR ORIFICE SIZE	0.059
DIMENSIONS	H X W X D
OUTDOOR UNIT - CRATED (IN.)	29-1/4 X 34-3/4 X 30-1/2
UNCRATED	SEE OUTLINE DWG.
WEIGHT	
SHIPPING (LBS.)	227
NET (LBS.)	215

- ① CERTIFIED IN ACCORDANCE WITH A.R.I. STANDARD 210/240.
- ② RATED IN ACCORDANCE WITH A.R.I. STANDARD 270.



SPLIT SYSTEM

- ③ CALCULATED IN ACCORDANCE WITH NATL. ELECTRIC CODE. SUITABLE FOR USE WITH HACR CIRCUIT BREAKERS OR FUSES.
- ④ STANDARD AIR - DRY COIL - OUTDOOR
- ⑤ THIS VALUE APPROXIMATE. FOR MORE PRECISE VALUE SEE UNIT NAMEPLATE AND SERVICE INSTRUCTION.
- ⑥ MAX. LINEAR LENGTH 80 FT; MAX. LIFT - SUCTION 60 FT; MAX. LIFT - LIQUID 60 FT. MAX. LENGTH OF PRECHARGED TUBING 50 FT. FOR GREATER LENGTH REFER TO REFRIGERANT PIPING MANUAL PUB. NO. 32-3009.



OUTDOOR UNIT WITH HEAT PUMP COILS

	TXA024C4	TXA025C4	TXA030C4	TXA031C4	TXA035C4	TXC024C4	TXC025C4
EXPANSION TYPE	CHG TO 59	CHG TO 59	CHG TO 59	CHG TO 59	CHG TO 59	CHG TO 59	CHG TO 59
RATINGS (COOLING) ①							
BTUH (TOTAL)	22800	23200	24000	24200	24000	22800	23200
BTUH (SENSIBLE)	15100	16100	16600	17700	16600	15100	16100
INDOOR AIRFLOW (CFM)	800	800	885	890	885	800	800
SYSTEM POWER (KW)	2.19	2.21	2.26	2.27	2.29	2.19	2.21
SEER (BTU/WATT-HR.)	10.65	10.75	11.00	11.00	11.00	10.65	10.75
RATINGS (HEATING) ①							
(HIGH TEMP.) BTUH	22200	22800	23000	23400	23000	22200	22800
SYSTEM POWER (KW)	2.17	2.13	2.15	2.12	2.15	2.17	2.13
COP	3.00	3.14	3.14	3.24	3.14	3.00	3.14
HSPF (BTU/WATT-HR.)	7.00	7.30	7.30	7.50	7.30	7.00	7.30

	TXC030C4	TXC031C4	TXC031E5	TXC031S3	TXC035C4	TXC036E5	TXC036S3
EXPANSION TYPE	CHG TO 59	CHG TO 59	TXV-B	TXV-NB	CHG TO 59	TXV-B	TXV-NB
RATINGS (COOLING) ①							
BTUH (TOTAL)	24000	24200	24800	24800	24000	25400	25400
BTUH (SENSIBLE)	16600	17700	18100	18100	16600	18700	18700
INDOOR AIRFLOW (CFM)	885	890	900	900	885	900	900
SYSTEM POWER (KW)	2.26	2.27	2.31	2.31	2.29	2.32	2.32
SEER (BTU/WATT-HR.)	11.00	11.00	11.25	11.90	10.75	11.40	11.90
RATINGS (HEATING) ①							
(HIGH TEMP.) BTUH	23000	23400	23600	23600	23000	23800	23800
SYSTEM POWER (KW)	2.15	2.12	2.10	2.10	2.15	2.05	2.05
COP	3.14	3.24	3.30	3.30	3.14	3.40	3.40
HSPF (BTU/WATT-HR.)	7.30	7.50	7.50	7.50	7.30	7.70	7.70

*See pages 24 and 25 for combinations with Auxiliary Devices.



General Data

TWN024C100A

OUTDOOR UNIT WITH HEAT PUMP COILS

	TXC037E5	TXC037S3	TXH025A4	TXH033A4
EXPANSION TYPE	TXV-B	TXV-NB	CHG TO 59	CHG TO 59
RATINGS (COOLING) ①				
BTUH (TOTAL)	25400	25400	23000	24400
BTUH (SENSIBLE)	18700	18700	15300	17600
INDOOR AIRFLOW (CFM)	900	900	800	900
SYSTEM POWER (KW)	2.32	2.32	2.21	2.30
SEER (BTU/WATT-HR.)	11.40	11.90	11.00	11.20
RATINGS (HEATING) ①				
(HIGH TEMP.) BTUH	23800	23800	22200	23400
SYSTEM POWER (KW)	2.05	2.05	2.17	2.13
COP	3.40	3.40	3.00	3.22
HSPF (BTU/WATT-HR.)	7.70	7.70	7.10	7.50

OUTDOOR UNIT WITH AIR HANDLERS

	TWE018C14	TWE018P13	TWE024C14	TWE024P13	TWE030C14	TWE030P13	TWE031E13
EXPANSION TYPE	CHG TO 59	TXV-NB	CHG TO 59	TXV-NB	CHG TO 59	TXV-NB	TXV-NB
RATINGS (COOLING) ①							
BTUH (TOTAL)	22200	23200	22600	24000	23600	24400	24600
BTUH (SENSIBLE)	14200	15400	15100	16700	16900	17600	17500
INDOOR AIRFLOW (CFM)	675	675	800	800	865	900	825
SYSTEM POWER (KW)	2.13	2.18	2.19	2.23	2.26	2.28	2.09
SEER (BTU/WATT-HR.)	11.20	11.90	11.15	11.90	11.00	11.60	11.80
RATINGS (HEATING) ①							
(HIGH TEMP.) BTUH	21600	22400	22000	22800	23000	23200	22400
SYSTEM POWER (KW)	2.18	2.10	2.16	2.10	2.15	2.11	1.95
COP	2.90	3.12	2.98	3.18	3.14	3.22	3.36
HSPF (BTU/WATT-HR.)	7.00	7.30	7.05	7.40	7.30	7.50	7.70

	TWE036C14	TWE036P13	TWE037E13	TWE040E13	TWG025A14	TWG030A14	TWH018B14
EXPANSION TYPE	CHG TO 59	TXV-NB	TXV-NB	TXV-NB	CHG TO 59	CHG TO 59	CHG TO 59
RATINGS (COOLING) ①							
BTUH (TOTAL)	24400	24600	25000	26600	22400	23400	23200
BTUH (SENSIBLE)	17600	18000	17700	20200	15300	16500	15800
INDOOR AIRFLOW (CFM)	895	900	800	875	800	875	675
SYSTEM POWER (KW)	2.30	2.33	2.08	2.11	2.09	2.25	2.15
SEER (BTU/WATT-HR.)	11.05	11.50	11.85	11.90	11.00	10.85	11.25
RATINGS (HEATING) ①							
(HIGH TEMP.) BTUH	23200	23400	22400	23200	22000	22800	22400
SYSTEM POWER (KW)	2.15	2.12	1.91	1.83	2.16	2.26	2.09
COP	3.16	3.24	3.44	3.72	2.98	2.96	3.14
HSPF (BTU/WATT-HR.)	7.30	7.50	7.85	8.25	7.00	7.00	7.30

	TWH024B14	TWH030B14-B	TWH036B14	TWV018B14	TWV024B14	TWV025B14	TWV030B14
EXPANSION TYPE	CHG TO 59	CHG TO 59	CHG TO 59	CHG TO 59	CHG TO 59	CHG TO 59	CHG TO 59
RATINGS (COOLING) ①							
BTUH (TOTAL)	24000	24800	25200	23000	23800	24200	24800
BTUH (SENSIBLE)	17200	18700	19100	15600	17000	17300	18700
INDOOR AIRFLOW (CFM)	800	900	900	675	800	800	900
SYSTEM POWER (KW)	2.19	2.29	2.31	2.18	2.25	2.24	2.28
SEER (BTU/WATT-HR.)	11.40	11.30	11.35	11.05	11.10	11.00	11.35
RATINGS (HEATING) ①							
(HIGH TEMP.) BTUH	22800	23400	23600	22400	23000	23200	23400
SYSTEM POWER (KW)	2.09	2.09	2.08	2.12	2.13	2.09	2.09
COP	3.20	3.28	3.32	3.10	3.16	3.26	3.28
HSPF (BTU/WATT-HR.)	7.40	7.50	7.60	7.20	7.30	7.50	7.50

*See pages 24 and 25 for combinations with Auxiliary Devices.



General Data

TWN024C100A

OUTDOOR UNIT WITH AIR HANDLERS

TWV036B14	
EXPANSION TYPE	CHG TO 59
RATINGS (COOLING) ①	
BTUH (TOTAL)	25000
BTUH (SENSIBLE)	18900
INDOOR AIRFLOW (CFM)	900
SYSTEM POWER (KW)	2.35
SEER (BTU/WATT-HR.)	11.10
RATINGS (HEATING) ①	
(HIGH TEMP.) BTUH	23800
SYSTEM POWER (KW)	2.14
COP	3.26
HSPF (BTU/WATT-HR.)	7.50

OUTDOOR UNIT WITH FURNACES & COILS

	TDD080R9V3 +TXC031E5	TDD080R9V3 +TXC031S3	TDD080R9V3 +TXC036E5	TDD080R9V3 +TXC036S3	TDD100R9V5 +TXC037E5	TDD100R9V5 +TXC037S3	TUD080R9V3 +TXC031E5
EXPANSION TYPE	TXV-B	TXV-NB	TXV-B	TXV-NB	TXV-B	TXV-NB	TXV-B
RATINGS (COOLING) ①							
BTUH (TOTAL)	24800	24800	25600	25600	25600	25600	25000
BTUH (SENSIBLE)	17400	17400	18200	18200	18300	18300	17700
INDOOR AIRFLOW (CFM)	775	775	775	775	800	800	800
SYSTEM POWER (KW)	2.08	2.08	2.10	2.10	2.07	2.07	2.13
SEER (BTU/WATT-HR.)	11.80	11.90	11.90	11.90	11.90	11.90	11.80
RATINGS (HEATING) ①							
(HIGH TEMP.) BTUH	22600	22600	22800	22800	22800	22800	22600
SYSTEM POWER (KW)	1.93	1.93	1.87	1.87	1.86	1.86	1.94
COP	3.44	3.44	3.58	3.58	3.60	3.60	3.42
HSPF (BTU/WATT-HR.)	7.85	7.85	8.00	8.00	8.05	8.05	7.80

	TUD080R9V3 +TXC031S3	TUD080R9V3 +TXC036E5	TUD080R9V3 +TXC036S3	TUD100R9V5 +TXC037E5	TUD100R9V5 +TXC037S3	TUY080R9V3A +TXC031E5	TUY080R9V3A +TXC031S3
EXPANSION TYPE	TXV-NB	TXV-B	TXV-NB	TXV-B	TXV-NB	TXV-B	TXV-NB
RATINGS (COOLING) ①							
BTUH (TOTAL)	25000	25600	25600	25600	25600	25000	25000
BTUH (SENSIBLE)	17700	18400	18400	18300	18300	17700	17700
INDOOR AIRFLOW (CFM)	800	825	825	800	800	800	800
SYSTEM POWER (KW)	2.13	2.12	2.12	2.08	2.08	2.12	2.12
SEER (BTU/WATT-HR.)	11.90	11.90	11.90	11.90	11.90	11.85	11.90
RATINGS (HEATING) ①							
(HIGH TEMP.) BTUH	22600	23000	23000	22800	22800	22600	22600
SYSTEM POWER (KW)	1.94	1.89	1.89	1.86	1.86	1.94	1.94
COP	3.42	3.56	3.56	3.60	3.60	3.42	3.42
HSPF (BTU/WATT-HR.)	7.80	8.00	8.00	8.05	8.05	7.80	7.80

	TUY080R9V3A +TXC036E5	TUY080R9V3A +TXC036S3
EXPANSION TYPE	TXV-B	TXV-NB
RATINGS (COOLING) ①		
BTUH (TOTAL)	25600	25600
BTUH (SENSIBLE)	18200	18200
INDOOR AIRFLOW (CFM)	800	800
SYSTEM POWER (KW)	2.12	2.12
SEER (BTU/WATT-HR.)	11.90	11.90
RATINGS (HEATING) ①		
(HIGH TEMP.) BTUH	23000	23000
SYSTEM POWER (KW)	1.90	1.90
COP	3.54	3.54
HSPF (BTU/WATT-HR.)	8.00	8.00

*See pages 24 and 25 for combinations with Auxiliary Devices.



General Data

TWN030C100A

OUTDOOR UNIT ①②	TWN030C100A
NOISE RATING (DECIBELS) ②	78
POWER CONNS. — V/PH/Hz	200/230/01/60
MIN. BRCH. CIR. AMPACITY ③	16
BR. CIR. } MAX. (AMPS)	25
PROT. RTG. } RECMD. (AMPS)	25
COMPRESSOR	CLIMATUFF®
NO. USED - NO. SPEEDS	1 - 1
VOLTS/PH/Hz	200/230/1/60
R.L. AMPS - L.R. AMPS	12 - 65
BRCH. CIR. SELEC. CUR. AMPS	12
OUTDOOR FAN — TYPE	PROPELLER
DIA. (IN.) - NO. USED	22 - 1
TYPE DRIVE - NO. SPEEDS	DIRECT - 1
CFM @ 0.0 IN. W.G. ④	2545
NO. MOTORS - HP	1 - 1/6
MOTOR SPEED R.P.M.	825
VOLTS/PH/Hz	200/230/1/60
FL. AMPS	0.90
OUTDOOR COIL — TYPE	SPINE FIN™
ROWS - F.P.I.	1 - 24
FACE AREA (SQ. FT.)	20.32
TUBE SIZE (IN.)	3/8
REFRIGERANT CONTROL	EXPANSION VALVE
REFRIGERANT	
LBS. — R-22 (O.D. UNIT) ⑤	6-LBS., 8-OZ.
FACTORY SUPPLIED	YES
LINE SIZE - IN. O.D. GAS ⑥	3/4
LINE SIZE - IN. O.D. LIQ. ⑥	5/16
FCCV — RESTRICTOR ORIFICE SIZE	0.067
DIMENSIONS	H X W X D
OUTDOOR UNIT - CRATED (IN.)	33-1/4 X 34-3/4 X 30-1/2
UNCRATED	SEE OUTLINE DWG.
WEIGHT	
SHIPPING (LBS.)	244
NET (LBS.)	232

- ① CERTIFIED IN ACCORDANCE WITH A.R.I. STANDARD 210/240.
- ② RATED IN ACCORDANCE WITH A.R.I. STANDARD 270.



SPLIT SYSTEM

- ③ CALCULATED IN ACCORDANCE WITH NATL. ELECTRIC CODE. SUITABLE FOR USE WITH HACR CIRCUIT BREAKERS OR FUSES.
- ④ STANDARD AIR - DRY COIL - OUTDOOR
- ⑤ THIS VALUE APPROXIMATE. FOR MORE PRECISE VALUE SEE UNIT NAMEPLATE AND SERVICE INSTRUCTION.
- ⑥ MAX. LINEAR LENGTH 80 FT; MAX. LIFT - SUCTION 60 FT; MAX. LIFT - LIQUID 60 FT. MAX. LENGTH OF PRECHARGED TUBING 50 FT. FOR GREATER LENGTH REFER TO REFRIGERANT PIPING MANUAL PUB. NO. 32-3009.



OUTDOOR UNIT WITH HEAT PUMP COILS

	TXA030C4	TXA031C4	TXA035C4	TXA036C4	TXA037C4	TXC030C4	TXC031C4
EXPANSION TYPE	FACT INS 67	FACT INS 67	CHG TO 67	CHG TO 67	CHG TO 67	FACT INS 67	FACT INS 67
RATINGS (COOLING) ①							
BTUH (TOTAL)	28800	29000	29200	30200	30200	28800	29000
BTUH (SENSIBLE)	19100	20100	19900	22000	22000	19100	20100
INDOOR AIRFLOW (CFM)	1000	1000	1075	1110	1110	1000	1000
SYSTEM POWER (KW)	2.88	2.89	2.93	2.98	2.98	2.88	2.89
SEER (BTU/WATT-HR.)	10.70	11.00	10.65	11.00	11.00	10.70	11.00
RATINGS (HEATING) ①							
(HIGH TEMP.) BTUH	27600	28200	27800	28800	28800	27600	28200
SYSTEM POWER (KW)	2.58	2.54	2.59	2.51	2.51	2.58	2.54
COP	3.14	3.26	3.14	3.36	3.36	3.14	3.26
HSPF (BTU/WATT-HR.)	7.35	7.55	7.35	7.65	7.65	7.35	7.55

	TXC031E5	TXC031S3	TXC035C4	TXC036C4	TXC036E5	TXC036S3	TXC037C4
EXPANSION TYPE	TXV-B	TXV-NB	CHG TO 67	CHG TO 67	TXV-B	TXV-NB	CHG TO 67
RATINGS (COOLING) ①							
BTUH (TOTAL)	30000	30000	29200	30200	31200	31200	30200
BTUH (SENSIBLE)	20800	20800	19900	22000	22900	22900	22000
INDOOR AIRFLOW (CFM)	1000	1000	1075	1110	1125	1125	1110
SYSTEM POWER (KW)	2.93	2.93	2.93	2.98	3.01	3.01	2.98
SEER (BTU/WATT-HR.)	11.10	11.65	10.65	11.00	11.20	11.85	11.00
RATINGS (HEATING) ①							
(HIGH TEMP.) BTUH	28400	28400	27800	28800	29200	29200	28800
SYSTEM POWER (KW)	2.51	2.51	2.59	2.51	2.47	2.47	2.51
COP	3.32	3.32	3.14	3.36	3.46	3.46	3.36
HSPF (BTU/WATT-HR.)	7.65	7.65	7.35	7.65	7.80	7.80	7.65

*See page 25 for combinations with Auxiliary Devices.



General Data

TWN030C100A

OUTDOOR UNIT WITH HEAT PUMP COILS

	TXC037E5	TXC037S3	TXH033A4
EXPANSION TYPE	TXV-B	TXV-NB	CHG TO 67
RATINGS (COOLING) ①			
BTUH (TOTAL)	31200	31200	29200
BTUH (SENSIBLE)	22900	22900	20100
INDOOR AIRFLOW (CFM)	1125	1125	1000
SYSTEM POWER (KW)	3.01	3.01	2.89
SEER (BTU/WATT-HR.)	11.20	11.85	11.05
RATINGS (HEATING) ①			
(HIGH TEMP.) BTUH	29200	29200	28000
SYSTEM POWER (KW)	2.47	2.47	2.53
COP	3.46	3.46	3.24
HSPF (BTU/WATT-HR.)	7.80	7.80	7.50

OUTDOOR UNIT WITH AIR HANDLERS

	TWE024P13	TWE030C14	TWE030P13	TWE031E13	TWE036C14	TWE036P13	TWE037E13
EXPANSION TYPE	TXV-NB	FACT INS 67	TXV-NB	TXV-NB	CHG TO 67	TXV-NB	TXV-NB
RATINGS (COOLING) ①							
BTUH (TOTAL)	28800	28200	29200	30000	29800	30200	30400
BTUH (SENSIBLE)	19200	19100	19800	20900	21200	21800	21300
INDOOR AIRFLOW (CFM)	900	950	950	1025	1100	1115	1000
SYSTEM POWER (KW)	2.89	2.83	2.88	2.79	2.98	3.00	2.74
SEER (BTU/WATT-HR.)	11.35	11.00	11.50	11.80	11.00	11.25	11.85
RATINGS (HEATING) ①							
(HIGH TEMP.) BTUH	27600	27400	27600	27400	28400	28600	27600
SYSTEM POWER (KW)	2.58	2.56	2.53	2.40	2.58	2.54	2.34
COP	3.14	3.14	3.20	3.34	3.22	3.30	3.46
HSPF (BTU/WATT-HR.)	7.35	7.35	7.55	7.80	7.50	7.65	7.90

	TWE040E13	TWE042C14	TWE042P13	TWG036A14	TWH024B14	TWH030B14-B	TWH036B14
EXPANSION TYPE	TXV-NB	CHG TO 67	TXV-NB	CHG TO 67	CHG TO 67	CHG TO 67	CHG TO 67
RATINGS (COOLING) ①							
BTUH (TOTAL)	32400	30000	30800	29400	28800	29800	30800
BTUH (SENSIBLE)	23900	21800	22500	20700	19800	21400	23100
INDOOR AIRFLOW (CFM)	1050	1105	1125	1085	900	1000	1125
SYSTEM POWER (KW)	2.78	2.99	3.03	2.94	2.80	2.89	3.03
SEER (BTU/WATT-HR.)	11.90	11.00	11.40	10.90	11.25	11.25	11.05
RATINGS (HEATING) ①							
(HIGH TEMP.) BTUH	28400	28800	29000	28000	27400	28200	29000
SYSTEM POWER (KW)	2.20	2.54	2.53	2.63	2.49	2.49	2.51
COP	3.78	3.32	3.36	3.12	3.22	3.32	3.38
HSPF (BTU/WATT-HR.)	8.40	7.60	7.75	7.25	7.50	7.65	7.65

	TWV025B14	TWV030B14	TWV036B14
EXPANSION TYPE	CHG TO 67	FACT INS 67	CHG TO 67
RATINGS (COOLING) ①			
BTUH (TOTAL)	28600	29200	30600
BTUH (SENSIBLE)	19600	20900	23000
INDOOR AIRFLOW (CFM)	900	1000	1125
SYSTEM POWER (KW)	2.87	2.78	3.04
SEER (BTU/WATT-HR.)	11.00	11.00	11.00
RATINGS (HEATING) ①			
(HIGH TEMP.) BTUH	27600	28800	29200
SYSTEM POWER (KW)	2.56	2.50	2.55
COP	3.16	3.38	3.36
HSPF (BTU/WATT-HR.)	7.40	7.75	7.65

*See page 25 for combinations with Auxiliary Devices.



General Data

TWN030C100A

OUTDOOR UNIT WITH FURNACES & COILS

	TDD080R9V3 +TXC031E5	TDD080R9V3 +TXC031S3	TDD080R9V3 +TXC036E5	TDD080R9V3 +TXC036S3	TDD100R9V5 +TXC037E5	TDD100R9V5 +TXC037S3	TDD100R9V5 +TXC054E5
EXPANSION TYPE	TXV-B	TXV-NB	TXV-B	TXV-NB	TXV-B	TXV-NB	TXV-B
RATINGS (COOLING) ①							
BTUH (TOTAL)	30200	30200	31000	31000	31400	31400	31200
BTUH (SENSIBLE)	20800	20800	21600	21600	22100	22100	22300
INDOOR AIRFLOW (CFM)	950	950	950	950	975	975	975
SYSTEM POWER (KW)	2.76	2.76	2.76	2.76	2.75	2.75	2.74
SEER (BTU/WATT-HR.)	11.80	11.90	11.90	11.90	11.90	11.90	11.90
RATINGS (HEATING) ①							
(HIGH TEMP.) BTUH	27600	27600	28000	28000	28000	28000	28200
SYSTEM POWER (KW)	2.35	2.35	2.29	2.29	2.27	2.27	2.26
COP	3.44	3.44	3.58	3.58	3.62	3.62	3.66
HSPF (BTU/WATT-HR.)	7.85	7.85	8.05	8.05	8.10	8.10	8.15

	TDD100R9V5 +TXC054S3	TUD080R9V3 +TXC031E5	TUD080R9V3 +TXC031S3	TUD080R9V3 +TXC036E5	TUD080R9V3 +TXC036S3	TUD100R9V5 +TXC037E5	TUD100R9V5 +TXC037S3
EXPANSION TYPE	TXV-NB	TXV-B	TXV-NB	TXV-B	TXV-NB	TXV-B	TXV-NB
RATINGS (COOLING) ①							
BTUH (TOTAL)	31200	30400	30400	31200	31200	31400	31400
BTUH (SENSIBLE)	22300	21200	21200	22000	22000	22200	22200
INDOOR AIRFLOW (CFM)	975	975	975	1000	1000	1000	1000
SYSTEM POWER (KW)	2.74	2.78	2.78	2.79	2.79	2.77	2.77
SEER (BTU/WATT-HR.)	11.90	11.80	11.90	11.90	11.90	11.90	11.90
RATINGS (HEATING) ①							
(HIGH TEMP.) BTUH	28000	27600	27600	28200	28200	28000	28000
SYSTEM POWER (KW)	2.23	2.35	2.35	2.31	2.31	2.27	2.27
COP	3.68	3.44	3.44	3.58	3.58	3.62	3.62
HSPF (BTU/WATT-HR.)	8.15	7.85	7.85	8.05	8.05	8.10	8.10

	TUD100R9V5 +TXC054E5	TUD100R9V5 +TXC054S3	TUY080R9V3A +TXC031E5	TUY080R9V3A +TXC031S3	TUY080R9V3A +TXC036E5	TUY080R9V3A +TXC036S3	TUY100R9V4A +TXC037E5
EXPANSION TYPE	TXV-B	TXV-NB	TXV-B	TXV-NB	TXV-B	TXV-NB	TXV-B
RATINGS (COOLING) ①							
BTUH (TOTAL)	31200	31200	30400	30400	31200	31200	31400
BTUH (SENSIBLE)	22400	22400	21200	21200	22000	22000	22200
INDOOR AIRFLOW (CFM)	1000	1000	1000	1000	1000	1000	1000
SYSTEM POWER (KW)	2.77	2.77	2.81	2.81	2.82	2.82	2.77
SEER (BTU/WATT-HR.)	11.90	11.90	11.70	11.75	11.80	11.90	11.90
RATINGS (HEATING) ①							
(HIGH TEMP.) BTUH	28200	28200	27800	27800	28200	28200	28000
SYSTEM POWER (KW)	2.26	2.26	2.38	2.38	2.33	2.33	2.27
COP	3.66	3.66	3.42	3.42	3.54	3.54	3.62
HSPF (BTU/WATT-HR.)	8.15	8.15	7.80	7.80	8.00	8.00	8.10

	TUY100R9V4A +TXC037S3	TUY100R9V4A +TXC054E5	TUY100R9V4A +TXC054S3
EXPANSION TYPE	TXV-NB	TXV-B	TXV-NB
RATINGS (COOLING) ①			
BTUH (TOTAL)	31400	31200	31200
BTUH (SENSIBLE)	22200	22400	22400
INDOOR AIRFLOW (CFM)	1000	1000	1000
SYSTEM POWER (KW)	2.77	2.76	2.76
SEER (BTU/WATT-HR.)	11.90	11.90	11.90
RATINGS (HEATING) ①			
(HIGH TEMP.) BTUH	28000	28200	28200
SYSTEM POWER (KW)	2.27	2.26	2.26
COP	3.62	3.66	3.66
HSPF (BTU/WATT-HR.)	8.10	8.15	8.15

*See page 25 for combinations with Auxiliary Devices.

General Data

TWN036C100B

OUTDOOR UNIT ①②	TWN036C100B
NOISE RATING (DECIBELS) ②	80
POWER CONNS. — V/PH/Hz	200/230/01/60
MIN. BRCH. CIR. AMPACITY ③	21
BR. CIR. } MAX. (AMPS)	35
PROT. RTG. } RECMD. (AMPS)	30
COMPRESSOR	CLIMATUFF®
NO. USED - NO. SPEEDS	1 - 1
VOLTS/PH/Hz	200/230/1/60
R.L. AMPS - L.R. AMPS	15 - 79
BRCH. CIR. SELEC. CUR. AMPS	15
OUTDOOR FAN — TYPE	PROPELLER
DIA. (IN.) - NO. USED	26 - 1
TYPE DRIVE - NO. SPEEDS	DIRECT - 1
CFM @ 0.0 IN. W.G. ④	3315
NO. MOTORS - HP	1 - 1/4
MOTOR SPEED R.P.M.	825
VOLTS/PH/Hz	200/230/1/60
FL. AMPS	1.9
OUTDOOR COIL — TYPE	SPINE FIN™
ROWS - F.P.I.	1 - 24
FACE AREA (SQ. FT.)	28.91
TUBE SIZE (IN.)	3/8
REFRIGERANT CONTROL	EXPANSION VALVE
REFRIGERANT	
LBS. — R-22 (O.D. UNIT) ⑤	9 LBS., 15 OZ.
FACTORY SUPPLIED	YES
LINE SIZE - IN. O.D. GAS ⑥	7/8
LINE SIZE - IN. O.D. LIQ. ⑥	3/8
FCCV — RESTRICTOR ORIFICE SIZE	0.075
DIMENSIONS	H X W X D
OUTDOOR UNIT - CRATED (IN.)	37-1/2 X 40-3/4 X 36-1/2
UNCRATED	SEE OUTLINE DWG.
WEIGHT	
SHIPPING (LBS.)	293
NET (LBS.)	278

① CERTIFIED IN ACCORDANCE WITH A.R.I. STANDARD 210/240.

② RATED IN ACCORDANCE WITH A.R.I. STANDARD 270.



SPLIT SYSTEM

③ CALCULATED IN ACCORDANCE WITH NATL. ELECTRIC CODE. SUITABLE FOR USE WITH HACR CIRCUIT BREAKERS OR FUSES.

④ STANDARD AIR - DRY COIL - OUTDOOR

⑤ THIS VALUE APPROXIMATE. FOR MORE PRECISE VALUE SEE UNIT NAMEPLATE AND SERVICE INSTRUCTION.

⑥ MAX. LINEAR LENGTH 80 FT; MAX. LIFT - SUCTION 60 FT; MAX. LIFT - LIQUID 60 FT. MAX. LENGTH OF PRECHARGED TUBING 50 FT. FOR GREATER LENGTH REFER TO REFRIGERANT PIPING MANUAL PUB. NO. 32-3009.



OUTDOOR UNIT WITH HEAT PUMP COILS

	TXA036C4	TXA037C4	TXA042C4	TXA043C4	TXA050C4	TXC031E5	TXC031S3
EXPANSION TYPE	CHG TO 75	CHG TO 75	CHG TO 75	CHG TO 75	CHG TO 75	TXV-B	TXV-NB
RATINGS (COOLING) ①							
BTUH (TOTAL)	36400	36400	37000	37400	38000	36600	36600
BTUH (SENSIBLE)	24800	24800	25600	26600	27200	24300	24300
INDOOR AIRFLOW (CFM)	1200	1200	1250	1350	1350	1100	1100
SYSTEM POWER (KW)	3.42	3.42	3.46	3.51	3.52	3.42	3.42
SEER (BTU/WATT-HR.)	11.00	11.00	11.00	11.00	11.00	11.10	11.65
RATINGS (HEATING) ①							
(HIGH TEMP.) BTUH	36800	36800	37200	37600	38000	36400	36400
SYSTEM POWER (KW)	3.35	3.35	3.32	3.32	3.30	3.33	3.33
COP	3.22	3.22	3.28	3.32	3.38	3.20	3.20
HSPF (BTU/WATT-HR.)	7.50	7.50	7.55	7.55	7.65	7.50	7.50

	TXC036C4	TXC036E5	TXC036S3	TXC037C4	TXC037E5	TXC037S3	TXC042C4
EXPANSION TYPE	CHG TO 75	TXV-B	TXV-NB	CHG TO 75	TXV-B	TXV-NB	CHG TO 75
RATINGS (COOLING) ①							
BTUH (TOTAL)	36400	37800	37800	36400	37800	37800	37000
BTUH (SENSIBLE)	24800	25900	25900	24800	25900	25900	25600
INDOOR AIRFLOW (CFM)	1200	1200	1200	1200	1200	1200	1250
SYSTEM POWER (KW)	3.42	3.47	3.47	3.42	3.47	3.47	3.46
SEER (BTU/WATT-HR.)	11.00	11.30	11.90	11.00	11.30	11.90	11.00
RATINGS (HEATING) ①							
(HIGH TEMP.) BTUH	36800	37400	37400	36800	37400	37400	37200
SYSTEM POWER (KW)	3.35	3.28	3.28	3.35	3.28	3.28	3.32
COP	3.22	3.34	3.34	3.22	3.34	3.34	3.28
HSPF (BTU/WATT-HR.)	7.50	7.60	7.60	7.50	7.60	7.60	7.55

*See pages 25 and 26 for combinations with Auxiliary Devices.



General Data

TWN036C100B

OUTDOOR UNIT WITH HEAT PUMP COILS

	TXC043C4	TXC050C4	TXC054E5	TXC054S3	TXH041A4
EXPANSION TYPE	CHG TO 75	CHG TO 75	TXV-B	TXV-NB	CHG TO 75
RATINGS (COOLING) ①					
BTUH (TOTAL)	37400	38000	38000	38000	38000
BTUH (SENSIBLE)	26600	27200	27400	27400	26700
INDOOR AIRFLOW (CFM)	1350	1350	1350	1350	1350
SYSTEM POWER (KW)	3.51	3.52	3.52	3.52	3.52
SEER (BTU/WATT-HR.)	11.00	11.00	11.20	11.85	11.65
RATINGS (HEATING) ①					
(HIGH TEMP.) BTUH	37600	38000	38000	38000	37600
SYSTEM POWER (KW)	3.32	3.30	3.26	3.26	3.32
COP	3.32	3.38	3.42	3.42	3.32
HSPF (BTU/WATT-HR.)	7.55	7.65	7.75	7.75	7.55

OUTDOOR UNIT WITH AIR HANDLERS

	TWE030P13	TWE036C14	TWE036P13	TWE037E13	TWE040E13	TWE042C14	TWE042P13
EXPANSION TYPE	TXV-NB	CHG TO 75	TXV-NB	TXV-NB	TXV-NB	CHG TO 75	TXV-NB
RATINGS (COOLING) ①							
BTUH (TOTAL)	34600	36000	36600	37400	40000	36200	38000
BTUH (SENSIBLE)	22200	24100	24700	25500	29100	24700	26900
INDOOR AIRFLOW (CFM)	950	1200	1200	1200	1275	1200	1350
SYSTEM POWER (KW)	3.30	3.41	3.47	3.30	3.31	3.45	3.57
SEER (BTU/WATT-HR.)	11.25	11.05	11.50	11.85	11.90	11.00	11.55
RATINGS (HEATING) ①							
(HIGH TEMP.) BTUH	34600	36000	36600	36000	37400	36800	37800
SYSTEM POWER (KW)	3.38	3.40	3.39	3.20	3.01	3.39	3.36
COP	3.00	3.10	3.16	3.30	3.64	3.18	3.30
HSPF (BTU/WATT-HR.)	7.20	7.25	7.50	7.65	8.15	7.40	7.60

	TWE048C14-B	TWE048P13	TWG037A14	TWH030B14-B	TWH036B14	TWV030B14	TWV036B14
EXPANSION TYPE	CHG TO 75	TXV-NB	CHG TO 75	CHG TO 75	CHG TO 75	CHG TO 75	CHG TO 75
RATINGS (COOLING) ①							
BTUH (TOTAL)	38000	39000	35200	36000	37200	35800	36800
BTUH (SENSIBLE)	26900	29000	23400	24700	26100	24500	25800
INDOOR AIRFLOW (CFM)	1350	1350	1200	1125	1200	1125	1200
SYSTEM POWER (KW)	3.58	3.44	3.37	3.41	3.46	3.44	3.46
SEER (BTU/WATT-HR.)	11.10	11.90	11.00	11.10	11.30	11.00	11.00
RATINGS (HEATING) ①							
(HIGH TEMP.) BTUH	37800	38000	35400	36400	37200	36600	38000
SYSTEM POWER (KW)	3.38	3.28	3.44	3.38	3.34	3.42	3.35
COP	3.28	3.40	3.02	3.16	3.26	3.14	3.32
HSPF (BTU/WATT-HR.)	7.50	7.80	7.15	7.40	7.50	7.35	7.55

	TDD080R9V3 +TXC031E5	TDD080R9V3 +TXC031S3	TDD080R9V3 +TXC036E5	TDD080R9V3 +TXC036S3	TDD100R9V5 +TXC037E5	TDD100R9V5 +TXC037S3	TDD100R9V5 +TXC054E5
EXPANSION TYPE	TXV-B	TXV-NB	TXV-B	TXV-NB	TXV-B	TXV-NB	TXV-B
RATINGS (COOLING) ①							
BTUH (TOTAL)	37000	37000	38000	38000	38500	38500	38000
BTUH (SENSIBLE)	24700	24800	25800	25800	26500	26500	26500
INDOOR AIRFLOW (CFM)	1100	1125	1125	1125	1175	1175	1175
SYSTEM POWER (KW)	3.33	3.33	3.32	3.32	3.28	3.28	3.25
SEER (BTU/WATT-HR.)	11.70	11.80	11.80	11.80	11.85	11.85	11.85
RATINGS (HEATING) ①							
(HIGH TEMP.) BTUH	35800	36000	36600	36600	36600	36600	37000
SYSTEM POWER (KW)	3.26	3.26	3.17	3.17	3.10	3.10	3.12
COP	3.22	3.24	3.38	3.38	3.46	3.46	3.48
HSPF (BTU/WATT-HR.)	7.50	7.50	7.80	7.80	7.90	7.90	7.90

*See pages 25 and 26 for combinations with Auxiliary Devices.



General Data

TWN036C100B

OUTDOOR UNIT WITH FURNACES & COILS

	TDD100R9V5 +TXC054S3	TUD080R9V3 +TXC031E5	TUD080R9V3 +TXC031S3	TUD080R9V3 +TXC036E5	TUD080R9V3 +TXC036S3	TUD080R9V3 +TXC054S3	TUD100R9V5 +TXC037E5
EXPANSION TYPE	TXV-NB	TXV-B	TXV-NB	TXV-B	TXV-NB	TXV-NB	TXV-B
RATINGS (COOLING) ①							
BTUH (TOTAL)	38000	37200	37200	38000	38000	37800	38500
BTUH (SENSIBLE)	26500	25300	25300	26200	26200	26200	26600
INDOOR AIRFLOW (CFM)	1175	1200	1200	1200	1200	1175	1200
SYSTEM POWER (KW)	3.25	3.41	3.41	3.42	3.42	3.35	3.32
SEER (BTU/WATT-HR.)	11.85	11.70	11.70	11.80	11.80	11.80	11.85
RATINGS (HEATING) ①							
(HIGH TEMP.) BTUH	36800	36400	36400	37000	37000	37000	36800
SYSTEM POWER (KW)	3.06	3.27	3.29	3.23	3.23	3.15	3.14
COP	3.52	3.26	3.24	3.36	3.36	3.44	3.44
HSPF (BTU/WATT-HR.)	7.90	7.50	7.60	7.65	7.65	7.85	7.85

	TUD100R9V5 +TXC037S3	TUD100R9V5 +TXC054E5	TUD100R9V5 +TXC054S3	TUY080R9V3A +TXC031E5	TUY080R9V3A +TXC031S3	TUY080R9V3A +TXC036E5	TUY080R9V3A +TXC036S3
EXPANSION TYPE	TXV-NB	TXV-B	TXV-NB	TXV-B	TXV-NB	TXV-B	TXV-NB
RATINGS (COOLING) ①							
BTUH (TOTAL)	38500	38000	38000	37000	37000	37800	37800
BTUH (SENSIBLE)	26600	26500	26500	24900	24900	25700	25700
INDOOR AIRFLOW (CFM)	1200	1200	1200	1150	1150	1150	1150
SYSTEM POWER (KW)	3.32	3.29	3.29	3.39	3.39	3.38	3.38
SEER (BTU/WATT-HR.)	11.85	11.85	11.85	11.70	11.75	11.90	11.90
RATINGS (HEATING) ①							
(HIGH TEMP.) BTUH	36800	37000	37000	36200	36200	36800	36800
SYSTEM POWER (KW)	3.14	3.12	3.12	3.29	3.29	3.23	3.23
COP	3.44	3.48	3.48	3.22	3.22	3.34	3.34
HSPF (BTU/WATT-HR.)	7.85	7.90	7.90	7.50	7.50	7.65	7.65

	TUY100R9V4A +TXC037E5	TUY100R9V4A +TXC037S3	TUY100R9V4A +TXC054E5	TUY100R9V4A +TXC054S3
EXPANSION TYPE	TXV-B	TXV-NB	TXV-B	TXV-NB
RATINGS (COOLING) ①				
BTUH (TOTAL)	38500	38500	38000	38000
BTUH (SENSIBLE)	26500	26500	26400	26400
INDOOR AIRFLOW (CFM)	1175	1175	1175	1175
SYSTEM POWER (KW)	3.32	3.32	3.29	3.29
SEER (BTU/WATT-HR.)	11.90	11.90	11.90	11.90
RATINGS (HEATING) ①				
(HIGH TEMP.) BTUH	36600	36600	36800	36800
SYSTEM POWER (KW)	3.14	3.14	3.08	3.08
COP	3.42	3.42	3.50	3.50
HSPF (BTU/WATT-HR.)	7.85	7.85	8.00	8.00

*See pages 25 and 26 for combinations with Auxiliary Devices.



General Data

TWN042C100A

OUTDOOR UNIT ^{①②}	TWN042C100A
NOISE RATING (DECIBELS) ^②	80
POWER CONNS. — V/PH/Hz	200/230/1/60
MIN. BRCH. CIR. AMPACITY ^③	23
BR. CIR. } MAX. (AMPS)	40
PROT. RTG. } RECMD. (AMPS)	40
COMPRESSOR	CLIMATUFF®
NO. USED - NO. SPEEDS	1 - 1
VOLTS/PH/Hz	200/230/1/60
R.L. AMPS - L.R. AMPS	16 - 91
BRCH. CIR. SELEC. CUR. AMPS	17
OUTDOOR FAN — TYPE	PROPELLER
DIA. (IN.) - NO. USED	26 - 1
TYPE DRIVE - NO. SPEEDS	DIRECT - 1
CFM @ 0.0 IN. W.G. ^④	3305
NO. MOTORS - HP	1 - 1/4
MOTOR SPEED R.P.M.	825
VOLTS/PH/Hz	200/230/1/60
FL. AMPS	1.9
OUTDOOR COIL — TYPE	SPINE FIN™
ROWS - F.P.I.	1 - 24
FACE AREA (SQ. FT.)	28.91
TUBE SIZE (IN.)	3/8
REFRIGERANT CONTROL	EXPANSION VALVE
REFRIGERANT	
LBS. — R-22 (O.D. UNIT) ^⑤	9 LBS.
FACTORY SUPPLIED	YES
LINE SIZE - IN. O.D. GAS ^⑥	7/8
LINE SIZE - IN. O.D. LIQ. ^⑥	3/8
FCCV — RESTRICTOR ORIFICE SIZE	0.080
DIMENSIONS	H X W X D
OUTDOOR UNIT - CRATED (IN.)	37-1/2 X 40-3/4 X 36-1/2
UNCRATED	SEE OUTLINE DWG.
WEIGHT	
SHIPPING (LBS.)	300
NET (LBS.)	285

- ① CERTIFIED IN ACCORDANCE WITH A.R.I. STANDARD 210/240.
- ② RATED IN ACCORDANCE WITH A.R.I. STANDARD 270.



SPLIT SYSTEM

- ③ CALCULATED IN ACCORDANCE WITH NATL. ELECTRIC CODE. SUITABLE FOR USE WITH HACR CIRCUIT BREAKERS OR FUSES.
- ④ STANDARD AIR - DRY COIL - OUTDOOR
- ⑤ THIS VALUE APPROXIMATE. FOR MORE PRECISE VALUE SEE UNIT NAMEPLATE AND SERVICE INSTRUCTION.
- ⑥ MAX. LINEAR LENGTH 80 FT; MAX. LIFT - SUCTION 60 FT; MAX. LIFT - LIQUID 60 FT. MAX. LENGTH OF PRECHARGED TUBING 50 FT. FOR GREATER LENGTH REFER TO REFRIGERANT PIPING MANUAL PUB. NO. 32-3009.



OUTDOOR UNIT WITH HEAT PUMP COILS

	TXA042C4	TXA043C4	TXA048C4	TXA049C4	TXA050C4	TXC036E5	TXC036S3
EXPANSION TYPE	FACT INS 80	FACT INS 80	CHG TO 80	CHG TO 80	CHG TO 80	TXV-B	TXV-NB
RATINGS (COOLING) ^①							
BTUH (TOTAL)	40000	40500	41000	42000	42000	41500	41500
BTUH (SENSIBLE)	26900	28100	28400	30600	30600	28000	28000
INDOOR AIRFLOW (CFM)	1250	1400	1350	1545	1545	1275	1275
SYSTEM POWER (KW)	3.96	4.03	4.02	4.16	4.16	4.05	4.05
SEER (BTU/WATT-HR.)	10.80	10.80	10.90	10.85	10.90	11.15	11.75
RATINGS (HEATING) ^①							
(HIGH TEMP.) BTUH	40500	41000	41000	42000	42000	41000	41000
SYSTEM POWER (KW)	3.62	3.62	3.56	3.58	3.58	3.58	3.58
COP	3.28	3.32	3.38	3.44	3.44	3.36	3.36
HSPF (BTU/WATT-HR.)	7.80	7.85	8.00	8.00	8.00	8.00	8.00

	TXC037E5	TXC037S3	TXC042C4	TXC043C4	TXC048C4	TXC049C4	TXC050C4
EXPANSION TYPE	TXV-B	TXV-NB	FACT INS 80	FACT INS 80	CHG TO 80	CHG TO 80	CHG TO 80
RATINGS (COOLING) ^①							
BTUH (TOTAL)	42000	42000	40000	40500	41000	42000	42000
BTUH (SENSIBLE)	28700	28700	26900	28100	28400	30600	30600
INDOOR AIRFLOW (CFM)	1350	1350	1250	1400	1350	1545	1545
SYSTEM POWER (KW)	4.10	4.10	3.96	4.03	4.02	4.16	4.16
SEER (BTU/WATT-HR.)	11.15	11.70	10.80	10.80	10.90	10.85	10.90
RATINGS (HEATING) ^①							
(HIGH TEMP.) BTUH	41000	41000	40500	41000	41000	42000	42000
SYSTEM POWER (KW)	3.56	3.56	3.62	3.62	3.56	3.58	3.58
COP	3.38	3.38	3.32	3.32	3.38	3.44	3.44
HSPF (BTU/WATT-HR.)	8.00	8.00	7.80	7.85	8.00	8.00	8.00

*See page 26 for combinations with Auxiliary Devices.



General Data

TWN042C100A

OUTDOOR UNIT WITH HEAT PUMP COILS

	TXC054E5	TXC054S3	TXH041A4	TXH054A4
EXPANSION TYPE	TXV-B	TXV-NB	CHG TO 80	CHG TO 80
RATINGS (COOLING) ①				
BTUH (TOTAL)	42500	42500	41500	44000
BTUH (SENSIBLE)	31100	31100	28500	32800
INDOOR AIRFLOW (CFM)	1555	1555	1400	1575
SYSTEM POWER (KW)	4.19	4.19	4.07	4.23
SEER (BTU/WATT-HR.)	11.00	11.60	11.15	11.35
RATINGS (HEATING) ①				
(HIGH TEMP) BTUH	42000	42000	41000	42500
SYSTEM POWER (KW)	3.54	3.54	3.62	3.54
COP	3.48	3.48	3.32	3.52
HSPF (BTU/WATT-HR.)	8.10	8.10	7.85	8.10

OUTDOOR UNIT WITH AIR HANDLERS

	TWE036P13	TWE037E13	TWE040E13	TWE042C14-B	TWE042P13	TWE048C14-B	TWE048P13
EXPANSION TYPE	TXV-NB	TXV-NB	TXV-NB	FACT INS 80	TXV-NB	CHG TO 80	TXV-NB
RATINGS (COOLING) ①							
BTUH (TOTAL)	40500	41000	43000	41000	41500	42000	43000
BTUH (SENSIBLE)	27200	28100	29600	27900	28600	30100	32500
INDOOR AIRFLOW (CFM)	1350	1400	1225	1400	1400	1550	1575
SYSTEM POWER (KW)	4.13	3.94	3.87	3.98	4.11	4.20	4.15
SEER (BTU/WATT-HR.)	11.00	11.75	11.80	11.00	11.50	11.05	11.65
RATINGS (HEATING) ①							
(HIGH TEMP) BTUH	40500	40000	40500	41500	41000	42000	42000
SYSTEM POWER (KW)	3.76	3.55	3.33	3.78	3.64	3.71	3.58
COP	3.16	3.30	3.56	3.22	3.30	3.32	3.44
HSPF (BTU/WATT-HR.)	7.70	7.80	8.40	7.85	8.00	7.90	8.15

	TWE060A	TWE060C15-C TWE060D15-A	TWE063P13	TWE065E13	TWG042A14	TWH036B14	TWV036B14
EXPANSION TYPE	TXV-B	TXV-B	TXV-NB	TXV-NB	FACT INS 80	CHG TO 80	CHG TO 80
RATINGS (COOLING) ①							
BTUH (TOTAL)	41500	41000	44500	45000	39000	40500	40500
BTUH (SENSIBLE)	30000	29500	33700	33000	26600	28400	28400
INDOOR AIRFLOW (CFM)	1535	1555	1575	1450	1400	1350	1350
SYSTEM POWER (KW)	4.09	4.25	4.43	3.96	4.02	4.11	4.15
SEER (BTU/WATT-HR.)	10.90	10.10	11.40	11.90	11.00	11.00	10.75
RATINGS (HEATING) ①							
(HIGH TEMP) BTUH	41000	42500	43500	42000	40000	41000	41500
SYSTEM POWER (KW)	3.56	3.75	3.64	3.26	3.73	3.69	3.78
COP	3.38	3.32	3.50	3.78	3.14	3.26	3.22
HSPF (BTU/WATT-HR.)	7.90	7.80	8.20	8.75	7.55	7.75	7.70

OUTDOOR UNIT WITH FURNACES & COILS

	TDD080R9V3 +TXC031S3	TDD080R9V3 +TXC036S3	TDD100R9V5 +TXC037E5	TDD100R9V5 +TXC037S3	TDD100R9V5 +TXC054E5	TDD100R9V5 +TXC054S3	TUD080R9V3 +TXC031S3
EXPANSION TYPE	TXV-NB	TXV-NB	TXV-B	TXV-NB	TXV-B	TXV-NB	TXV-NB
RATINGS (COOLING) ①							
BTUH (TOTAL)	41000	42000	42500	42500	42000	42000	41000
BTUH (SENSIBLE)	27600	28700	29500	29500	29500	29500	27600
INDOOR AIRFLOW (CFM)	1325	1325	1400	1400	1400	1400	1325
SYSTEM POWER (KW)	4.02	4.02	3.99	3.99	3.94	3.94	4.02
SEER (BTU/WATT-HR.)	11.40	11.75	11.60	11.70	11.70	11.70	11.40
RATINGS (HEATING) ①							
(HIGH TEMP) BTUH	40500	41000	41000	41000	41000	41000	40500
SYSTEM POWER (KW)	3.66	3.56	3.49	3.49	3.47	3.43	3.66
COP	3.24	3.38	3.44	3.44	3.46	3.50	3.24
HSPF (BTU/WATT-HR.)	7.85	8.10	8.10	8.10	8.15	8.15	7.85

*See page 26 for combinations with Auxiliary Devices.



General Data

TWN042C100A

OUTDOOR UNIT WITH FURNACES & COILS

	TUD080R9V3 +TXC036S3	TUD100R9V5 +TXC037E5	TUD100R9V5 +TXC037S3	TUD100R9V5 +TXC054E5	TUD100R9V5 +TXC054S3	TUY080R9V3A +TXC036E5	TUY080R9V3A +TXC036S3
EXPANSION TYPE	TXV-NB	TXV-B	TXV-NB	TXV-B	TXV-NB	TXV-B	TXV-NB
RATINGS (COOLING) ①							
BTUH (TOTAL)	42000	42000	42000	42000	42000	41500	41500
BTUH (SENSIBLE)	29100	29100	29100	29500	29500	28300	28300
INDOOR AIRFLOW (CFM)	1400	1400	1400	1400	1400	1325	1325
SYSTEM POWER (KW)	4.12	4.02	4.02	4.02	4.02	4.07	4.07
SEER (BTU/WATT-HR.)	11.45	11.60	11.65	11.70	11.65	11.60	11.70
RATINGS (HEATING) ①							
(HIGH TEMP.) BTUH	41500	41000	41000	41000	41000	41000	41000
SYSTEM POWER (KW)	3.62	3.53	3.53	3.47	3.47	3.62	3.62
COP	3.36	3.40	3.40	3.46	3.46	3.32	3.32
HSPF (BTU/WATT-HR.)	8.05	8.05	8.05	8.15	8.15	7.90	7.90

	TUY100R9V4A +TXC037E5	TUY100R9V4A +TXC037S3	TUY100R9V4A +TXC054E5	TUY100R9V4A +TXC054S3
EXPANSION TYPE	TXV-B	TXV-NB	TXV-B	TXV-NB
RATINGS (COOLING) ①				
BTUH (TOTAL)	42500	42500	42000	42000
BTUH (SENSIBLE)	29400	29400	29400	29400
INDOOR AIRFLOW (CFM)	1375	1375	1375	1375
SYSTEM POWER (KW)	3.99	3.99	3.96	3.96
SEER (BTU/WATT-HR.)	11.70	11.80	11.65	11.70
RATINGS (HEATING) ①				
(HIGH TEMP.) BTUH	40500	40500	41000	41000
SYSTEM POWER (KW)	3.45	3.45	3.45	3.45
COP	3.44	3.44	3.48	3.48
HSPF (BTU/WATT-HR.)	8.10	8.10	8.15	8.15

*See page 26 for combinations with Auxiliary Devices.



General Data

TWN048C100A

OUTDOOR UNIT ①②	TWN048C100A
NOISE RATING (DECIBELS) ②	80
POWER CONNS. — V/PH/Hz	200/230/01/60
MIN. BRCH. CIR. AMPACITY ③	29
BR. CIR. } MAX. (AMPS)	50
PROT. RTG. } RECMD. (AMPS)	50
COMPRESSOR	CLIMATUFF®
NO. USED - NO. SPEEDS	1 - 1
VOLTS/PH/Hz	200/230/1/60
R.L. AMPS - L.R. AMPS	20 - 122
BRCH. CIR. SELEC. CUR. AMPS	22
OUTDOOR FAN — TYPE	PROPELLER
DIA. (IN.) - NO. USED	26 - 1
TYPE DRIVE - NO. SPEEDS	DIRECT - 1
CFM @ 0.0 IN. W.G. ④	3285
NO. MOTORS - HP	1 - 1/4
MOTOR SPEED R.P.M.	825
VOLTS/PH/Hz	200/230/1/60
FL. AMPS	1.9
OUTDOOR COIL — TYPE	SPINE FIN™
ROWS - F.P.I.	1 - 24
FACE AREA (SQ. FT.)	28.91
TUBE SIZE (IN.)	3/8
REFRIGERANT CONTROL	EXPANSION VALVE
REFRIGERANT	
LBS. — R-22 (O.D. UNIT) ⑤	9 LBS., 14 OZ.
FACTORY SUPPLIED	YES
LINE SIZE - IN. O.D. GAS ⑥	1 1/8
LINE SIZE - IN. O.D. LIQ. ⑥	3/8
FCCV — RESTRICTOR ORIFICE SIZE	0.086
DIMENSIONS	H X W X D
OUTDOOR UNIT - CRATED (IN.)	37-1/2 X 40-3/4 X 36-1/2
UNCRATED	SEE OUTLINE DWG.
WEIGHT	
SHIPPING (LBS.)	309
NET (LBS.)	294

- ① CERTIFIED IN ACCORDANCE WITH A.R.I. STANDARD 210/240.
- ② RATED IN ACCORDANCE WITH A.R.I. STANDARD 270.



SPLIT SYSTEM

- ③ CALCULATED IN ACCORDANCE WITH NATL. ELECTRIC CODE. SUITABLE FOR USE WITH HACR CIRCUIT BREAKERS OR FUSES.
- ④ STANDARD AIR - DRY COIL - OUTDOOR
- ⑤ THIS VALUE APPROXIMATE. FOR MORE PRECISE VALUE SEE UNIT NAMEPLATE AND SERVICE INSTRUCTION.
- ⑥ MAX. LINEAR LENGTH 80 FT; MAX. LIFT - SUCTION 60 FT; MAX. LIFT - LIQUID 60 FT. MAX. LENGTH OF PRECHARGED TUBING 50 FT. FOR GREATER LENGTH REFER TO REFRIGERANT PIPING MANUAL PUB. NO. 32-3009.



OUTDOOR UNIT WITH HEAT PUMP COILS

	TXA048C4	TXA049C4	TXA050C4	TXA060C5	TXC048C4	TXC049C4	TXC050C4
EXPANSION TYPE	CHG TO 86	CHG TO 86	CHG TO 86	TXV-B	CHG TO 86	CHG TO 86	CHG TO 86
RATINGS (COOLING) ①							
BTUH (TOTAL)	46000	47500	47500	48500	46000	47500	47500
BTUH (SENSIBLE)	30200	32500	32500	33900	30200	32500	32500
INDOOR AIRFLOW (CFM)	1350	1600	1600	1700	1350	1600	1600
SYSTEM POWER (KW)	4.47	4.61	4.61	4.69	4.47	4.61	4.61
SEER (BTU/WATT-HR.)	11.00	11.00	11.00	11.00	11.00	11.00	11.00
RATINGS (HEATING) ①							
(HIGH TEMP.) BTUH	46000	47000	47000	47500	46000	47000	47000
SYSTEM POWER (KW)	4.16	4.17	4.17	4.14	4.16	4.17	4.17
COP	3.24	3.30	3.30	3.36	3.24	3.30	3.30
HSPF (BTU/WATT-HR.)	7.80	7.90	7.85	8.00	7.80	7.90	7.85

	TXC054E5	TXC054S3	TXC060C5	TXC065S3	TXH041A4	TXH054A4	TXH063P3
EXPANSION TYPE	TXV-B	TXV-NB	TXV-B	TXV-NB	CHG TO 86	CHG TO 86	TXV-NB
RATINGS (COOLING) ①							
BTUH (TOTAL)	48500	48500	48500	51000	48500	50500	52000
BTUH (SENSIBLE)	34000	34000	33900	36400	32500	35200	38200
INDOOR AIRFLOW (CFM)	1700	1700	1700	1800	1575	1600	1800
SYSTEM POWER (KW)	4.71	4.71	4.69	4.86	4.69	4.74	4.88
SEER (BTU/WATT-HR.)	11.00	11.50	11.00	11.90	11.35	11.65	11.90
RATINGS (HEATING) ①							
(HIGH TEMP.) BTUH	47500	47500	47500	48000	46500	47500	48500
SYSTEM POWER (KW)	4.14	4.14	4.14	4.09	4.23	4.09	4.08
COP	3.36	3.36	3.36	3.44	3.22	3.40	3.48
HSPF (BTU/WATT-HR.)	8.00	8.00	8.00	8.05	7.70	8.00	8.10

*See page 27 for combinations with Auxiliary Devices.



General Data

TWN048C100A

OUTDOOR UNIT WITH AIR HANDLERS

	TWE042P13	TWE048C14-B	TWE048P13	TWE060A	TWE060C15-C TWE060D15-A	TWE060P13	TWE063P13
EXPANSION TYPE	TXV-NB	CHG TO 86	TXV-NB	TXV-B	TXV-B	TXV-NB	TXV-NB
RATINGS (COOLING) ①							
BTUH (TOTAL)	47500	47500	49000	48000	48000	51500	51500
BTUH (SENSIBLE)	31900	32200	34400	33900	33600	37800	38000
INDOOR AIRFLOW (CFM)	1575	1600	1600	1795	1800	1800	1800
SYSTEM POWER (KW)	4.68	4.85	4.62	4.68	4.87	4.88	5.05
SEER (BTU/WATT-HR.)	11.20	11.00	11.65	10.85	10.20	11.75	11.35
RATINGS (HEATING) ①							
(HIGH TEMP.) BTUH	47000	47000	47000	47500	48500	48500	49000
SYSTEM POWER (KW)	4.33	4.12	4.15	4.24	4.39	4.11	4.20
COP	3.18	3.34	3.32	3.28	3.24	3.46	3.42
HSPF (BTU/WATT-HR.)	7.75	7.85	8.00	7.85	7.80	8.25	8.15

	TWE065E13	TWG048A14
EXPANSION TYPE	TXV-NB	CHG TO 86
RATINGS (COOLING) ①		
BTUH (TOTAL)	50500	47000
BTUH (SENSIBLE)	34300	31600
INDOOR AIRFLOW (CFM)	1375	1600
SYSTEM POWER (KW)	4.41	4.63
SEER (BTU/WATT-HR.)	11.90	11.00
RATINGS (HEATING) ①		
(HIGH TEMP.) BTUH	46500	46800
SYSTEM POWER (KW)	3.79	4.34
COP	3.60	3.16
HSPF (BTU/WATT-HR.)	8.50	7.70

OUTDOOR UNIT WITH FURNACES & COILS

	TDD100R9V5 +TXC054E5	TDD100R9V5 +TXC054S3	TDD100R9V5 +TXH063P3	TDD120R9V5 +TXH063P3	TUD100R9V5 +TXC054E5	TUD100R9V5 +TXC054S3	TUY100R9V4A +TXC054E5
EXPANSION TYPE	TXV-B	TXV-NB	TXV-NB	TXV-NB	TXV-B	TXV-NB	TXV-B
RATINGS (COOLING) ①							
BTUH (TOTAL)	47500	48000	51500	51500	47500	47500	49000
BTUH (SENSIBLE)	32800	33200	36400	36500	33100	33100	33700
INDOOR AIRFLOW (CFM)	1625	1625	1600	1600	1675	1675	1600
SYSTEM POWER (KW)	4.50	4.55	4.68	4.56	4.59	4.59	4.71
SEER (BTU/WATT-HR.)	11.05	11.30	11.90	11.90	11.05	11.05	11.70
RATINGS (HEATING) ①							
(HIGH TEMP.) BTUH	47500	47000	47500	47000	47500	47500	47000
SYSTEM POWER (KW)	4.17	4.10	3.95	3.85	4.17	4.17	4.15
COP	3.34	3.36	3.52	3.58	3.34	3.34	3.32
HSPF (BTU/WATT-HR.)	8.00	8.00	8.30	8.40	8.00	8.00	8.00

	TUY100R9V4A +TXC054S3	TUY120R9V5 +TXC065S3
EXPANSION TYPE	TXV-NB	TXV-NB
RATINGS (COOLING) ①		
BTUH (TOTAL)	49000	50000
BTUH (SENSIBLE)	33700	34400
INDOOR AIRFLOW (CFM)	1600	1600
SYSTEM POWER (KW)	4.71	4.72
SEER (BTU/WATT-HR.)	11.75	11.85
RATINGS (HEATING) ①		
(HIGH TEMP.) BTUH	47000	47500
SYSTEM POWER (KW)	4.15	4.09
COP	3.32	3.40
HSPF (BTU/WATT-HR.)	8.00	8.10

*See page 27 for combinations with Auxiliary Devices.



General Data

TWN060C100A

OUTDOOR UNIT ①②	TWN060C100A
NOISE RATING (DECIBELS) ②	80
POWER CONNS. — V/PH/Hz	200/230/01/60
MIN. BRCH. CIR. AMPACITY ③	38
BR. CIR. } MAX. (AMPS)	60
PROT. RTG. } RECMD. (AMPS)	60
COMPRESSOR	CLIMATUFF®
NO. USED - NO. SPEEDS	1 - 1
VOLTS/PH/Hz	200/230/1/60
R.L. AMPS - L.R. AMPS	26 - 145
BRCH. CIR. SELEC. CUR. AMPS	29
OUTDOOR FAN — TYPE	PROPELLER
DIA. (IN.) - NO. USED	26 - 1
TYPE DRIVE - NO. SPEEDS	DIRECT - 1
CFM @ 0.0 IN. W.G. ④	3545
NO. MOTORS - HP	1 - 1/4
MOTOR SPEED R.P.M.	825
VOLTS/PH/Hz	200/230/1/60
F.L. AMPS	1.9
OUTDOOR COIL — TYPE	SPINE FIN™
ROWS - F.P.I.	2 - 24
FACE AREA (SQ. FT.)	35.39
TUBE SIZE (IN.)	3/8
REFRIGERANT CONTROL	EXPANSION VALVE
REFRIGERANT	
LBS. — R-22 (O.D. UNIT) ⑤	16 LBS., 9 OZ.
FACTORY SUPPLIED	YES
LINE SIZE - IN. O.D. GAS ⑥	1 1/8
LINE SIZE - IN. O.D. LIQ. ⑥	3/8
FCCV — RESTRICTOR ORIFICE SIZE	0.095
DIMENSIONS	H X W X D
OUTDOOR UNIT - CRATED (IN.)	45-1/4 X 40-3/4 X 36-1/2
UNCRATED	SEE OUTLINE DWG.
WEIGHT	
SHIPPING (LBS.)	414
NET (LBS.)	389

- ① CERTIFIED IN ACCORDANCE WITH A.R.I. STANDARD 210/240.
- ② RATED IN ACCORDANCE WITH A.R.I. STANDARD 270.



SPLIT SYSTEM

- ③ CALCULATED IN ACCORDANCE WITH NATL. ELECTRIC CODE. SUITABLE FOR USE WITH HACR CIRCUIT BREAKERS OR FUSES.
- ④ STANDARD AIR - DRY COIL - OUTDOOR
- ⑤ THIS VALUE APPROXIMATE. FOR MORE PRECISE VALUE SEE UNIT NAMEPLATE AND SERVICE INSTRUCTION.
- ⑥ MAX. LINEAR LENGTH 80 FT; MAX. LIFT - SUCTION 60 FT; MAX. LIFT - LIQUID 60 FT. MAX. LENGTH OF PRECHARGED TUBING 50 FT. FOR GREATER LENGTH REFER TO REFRIGERANT PIPING MANUAL PUB. NO. 32-3009.



	OUTDOOR UNIT WITH HEAT PUMP COILS				WITH AIR HANDLERS		
	TXA060C5	TXC060C5	TXC065S3	TXH063P3	TWE048P13	TWE060P13	TWE063P13
EXPANSION TYPE	TXV-B	TXV-B	TXV-NB	TXV-NB	TXV-NB	TXV-NB	TXV-NB
RATINGS (COOLING) ①							
BTUH (TOTAL)	58000	58000	61000	62500	59500	61500	61000
BTUH (SENSIBLE)	38100	38100	41700	43900	40500	41900	41700
INDOOR AIRFLOW (CFM)	1700	1700	2000	2000	1800	1800	1825
SYSTEM POWER (KW)	5.95	5.95	6.19	6.25	5.95	6.15	6.29
SEER (BTU/WATT-HR.)	10.40	10.40	11.25	11.40	11.00	11.00	11.00
RATINGS (HEATING) ①							
(HIGH TEMP.) BTUH	58000	58000	59000	59500	58000	59000	57000
SYSTEM POWER (KW)	5.52	5.52	5.44	5.42	5.56	5.44	5.39
COP	3.08	3.08	3.18	3.22	3.06	3.18	3.10
HSPF (BTU/WATT-HR.)	7.90	7.90	8.05	8.10	8.00	8.25	8.00
	OUTDOOR UNIT WITH AIR HANDLERS			WITH FURNACES & COILS			
	TWE065E13	TWE090A	TWV060P15-C	TDD120R9V5 +TXH063P3			
EXPANSION TYPE	TXV-NB	TXV-NB	TXV-B	TXV-NB			
RATINGS (COOLING) ①							
BTUH (TOTAL)	63000	63000	60500	62500			
BTUH (SENSIBLE)	43800	44900	42800	43900			
INDOOR AIRFLOW (CFM)	1900	2250	2000	2000			
SYSTEM POWER (KW)	6.24	6.21	6.37	6.19			
SEER (BTU/WATT-HR.)	11.50	11.50	10.35	11.00			
RATINGS (HEATING) ①							
(HIGH TEMP.) BTUH	59500	59500	62000	59500			
SYSTEM POWER (KW)	5.35	5.35	5.57	5.42			
COP	3.26	3.26	3.26	3.22			
HSPF (BTU/WATT-HR.)	8.40	8.45	8.25	8.25			

*See page 27 for combinations with Auxiliary Devices.



Ratings with Auxiliary Devices

COMBINATIONS WITH FAN DELAY RELAY KIT AND/OR TXV KIT AND/OR INSULATION KIT

*When models are matched with an indoor air handler or coil that has a flow control check valve or expansion valve flow control, the addition of an indoor fan delay relay and/or TXV kit may increase the system SEER. The addition of a BAYINS001 kit on the outdoor unit may increase the system HSPF. See charts below for ratings.

OUTDOOR MODEL	INS KIT	INDOOR MODEL	FAN DELAY KIT	TXV KIT	CFM	SEER	COOLING CAPACITY	HI-TEMP HEATING	HSPF	HI-TEMP COP
TWN018C100B	Y	TDD080R9V3 +TXC031E5	-	N	600	11.90	18900	16300	7.50	3.64
TWN018C100B	Y	TUD080R9V3 +TXC031E5	-	N	600	11.80	18800	16400	7.50	3.58
TWN018C100B	Y	TUY080R9V3A +TXC031S3	-	N	575	11.90	18800	16300	7.50	3.58
TWN018C100B	Y	TWE030P13	N	N	675	11.50	18000	16600	7.00	3.14
TWN018C100B	Y	TWG025A14	-	N	665	11.00	17900	16200	6.80	3.16
TWN018C100B	Y	TWH018B14	-	N	600	11.00	17800	16300	7.00	3.14
TWN018C100B	Y	TWH024B14	-	N	675	11.15	18100	16500	7.00	3.22
TWN018C100B	Y	TWV018B14	-	N	600	11.00	17500	16600	7.20	3.24
TWN018C100B	Y	TWV024B14	-	N	675	11.00	18000	16600	7.00	3.14
TWN018C100B	Y	TWV025B14	-	N	675	11.00	18100	16500	7.00	3.18
TWN018C100B	Y	TXA018C4	N	N	600	10.50	16800	15700	6.80	2.86
TWN018C100B	Y	TXA018C4	Y	N	600	11.00	16800	15700	6.80	2.86
TWN018C100B	N	TXA024C4	Y	N	650	11.00	17400	16100	6.80	2.98
TWN018C100B	Y	TXA024C4	Y	N	650	11.00	17400	16100	7.00	2.98
TWN018C100B	N	TXA025C4	Y	N	665	11.10	17700	16500	6.80	3.14
TWN018C100B	Y	TXA025C4	Y	N	665	11.10	17700	16500	7.00	3.14
TWN018C100B	Y	TXC018C4	N	N	600	10.50	16800	15700	6.80	2.86
TWN018C100B	Y	TXC018C4	Y	N	600	11.00	16800	15700	6.80	2.86
TWN018C100B	N	TXC024C4	Y	N	650	11.00	17400	16100	6.80	2.98
TWN018C100B	Y	TXC024C4	Y	N	650	11.00	17400	16100	7.00	2.98
TWN018C100B	N	TXC025C4	Y	N	665	11.10	17700	16500	6.80	3.14
TWN018C100B	Y	TXC025C4	Y	N	665	11.10	17700	16500	7.00	3.14
TWN018C100B	N	TXH025A4	Y	N	650	11.35	17800	16500	6.80	3.12
TWN018C100B	N	TXH025A4	Y	Y	645	11.80	17600	16500	6.80	3.12
TWN024C100A	Y	TUY080R9V3A +TXC031S3	-	N	800	11.90	25000	22600	8.00	3.42
TWN024C100A	Y	TWE030C14	-	N	865	11.00	23600	23000	7.50	3.14
TWN024C100A	Y	TWE031E13	N	N	825	11.80	24600	22400	8.00	3.36
TWN024C100A	Y	TWE036C14	-	N	895	11.05	24400	23200	7.50	3.16
TWN024C100A	Y	TWH018B14	-	N	675	11.25	23200	22400	7.50	3.14
TWN024C100A	Y	TWH024B14	-	N	800	11.40	24000	22800	7.50	3.20
TWN024C100A	Y	TWV024B14	-	N	800	11.10	23800	23000	7.50	3.16
TWN024C100A	N	TXA024C4	Y	N	800	11.00	22800	22200	7.00	3.00
TWN024C100A	N	TXA025C4	Y	N	800	11.00	23200	22800	7.30	3.14
TWN024C100A	Y	TXA025C4	Y	N	800	11.00	23200	22800	7.50	3.14
TWN024C100A	N	TXA030C4	Y	N	885	11.30	24000	23000	7.30	3.14
TWN024C100A	Y	TXA030C4	Y	N	885	11.30	24000	23000	7.50	3.14
TWN024C100A	N	TXA031C4	Y	N	890	11.40	24200	23400	7.50	3.24
TWN024C100A	N	TXA035C4	Y	N	885	11.20	24000	23000	7.30	3.14
TWN024C100A	N	TXA035C4	N	Y	875	11.50	23800	23000	7.30	3.14
TWN024C100A	N	TXC024C4	Y	N	800	11.00	22800	22200	7.00	3.00
TWN024C100A	N	TXC025C4	Y	N	800	11.00	23200	22800	7.30	3.14
TWN024C100A	Y	TXC025C4	Y	N	800	11.00	23200	22800	7.50	3.14



Ratings with Auxiliary Devices

COMBINATIONS WITH FAN DELAY RELAY KIT AND/OR TXV KIT AND/OR INSULATION KIT

*When models are matched with an indoor air handler or coil that has a flow control check valve or expansion valve flow control, the addition of an indoor fan delay relay and/or TXV kit may increase the system SEER. The addition of a BAYINS001 kit on the outdoor unit may increase the system HSPF. See charts below for ratings.

OUTDOOR MODEL	INS KIT	INDOOR MODEL	FAN DELAY KIT	TXV KIT	CFM	SEER	COOLING CAPACITY	HI-TEMP HEATING	HSPF	HI-TEMP COP
TWN024C100A	N	TXC030C4	Y	N	885	11.30	24000	23000	7.30	3.14
TWN024C100A	Y	TXC030C4	Y	N	885	11.30	24000	23000	7.50	3.14
TWN024C100A	N	TXC031C4	Y	N	890	11.40	24200	23400	7.50	3.24
TWN024C100A	N	TXC031E5	Y	N	900	11.80	24800	23600	7.50	3.30
TWN024C100A	N	TXC035C4	Y	N	885	11.20	24000	23000	7.30	3.14
TWN024C100A	N	TXC035C4	N	Y	875	11.50	23800	23000	7.30	3.14
TWN024C100A	N	TXC036E5	Y	N	900	11.90	25400	23800	7.70	3.40
TWN024C100A	N	TXC037E5	Y	N	900	11.90	25400	23800	7.70	3.40
TWN024C100A	N	TXH025A4	Y	N	800	11.55	23000	22200	7.10	3.00
TWN024C100A	N	TXH033A4	Y	N	900	11.75	24400	23400	7.50	3.22
TWN030C100A	Y	TUY080R9V3A +TXC031S3	-	N	1000	11.75	30400	27800	8.00	3.42
TWN030C100A	Y	TWE030C14	-	N	950	11.00	28200	27400	7.50	3.14
TWN030C100A	Y	TWE031E13	N	N	1025	11.80	30000	27400	8.00	3.34
TWN030C100A	Y	TWV030B14	-	N	1000	11.00	29200	28800	8.00	3.38
TWN030C100A	N	TXA030C4	Y	N	1000	11.15	28800	27600	7.35	3.14
TWN030C100A	Y	TXA030C4	Y	N	1000	11.15	28800	27600	7.50	3.14
TWN030C100A	N	TXA031C4	Y	N	1000	11.20	29000	28200	7.55	3.26
TWN030C100A	N	TXA035C4	Y	N	1075	11.10	29200	27800	7.40	3.14
TWN030C100A	N	TXA035C4	N	Y	1075	11.20	29200	27800	7.35	3.14
TWN030C100A	N	TXA036C4	Y	N	1110	11.25	30200	28800	7.65	3.36
TWN030C100A	N	TXA037C4	Y	N	1110	11.25	30200	28800	7.65	3.36
TWN030C100A	N	TXC030C4	Y	N	1000	11.15	28800	27600	7.35	3.14
TWN030C100A	Y	TXC030C4	Y	N	1000	11.15	28800	27600	7.50	3.14
TWN030C100A	N	TXC031C4	Y	N	1000	11.20	29000	28200	7.55	3.26
TWN030C100A	N	TXC031E5	Y	N	1000	11.60	30000	28400	7.65	3.32
TWN030C100A	N	TXC035C4	Y	N	1075	11.10	29200	27800	7.40	3.14
TWN030C100A	N	TXC035C4	N	Y	1075	11.20	29200	27800	7.35	3.14
TWN030C100A	N	TXC036C4	Y	N	1110	11.25	30200	28800	7.65	3.36
TWN030C100A	N	TXC036E5	Y	N	1125	11.75	31200	29200	7.80	3.46
TWN030C100A	Y	TXC036E5	Y	N	1125	11.75	31200	29200	8.00	3.46
TWN030C100A	N	TXC037C4	Y	N	1110	11.25	30200	28800	7.65	3.36
TWN030C100A	N	TXC037E5	Y	N	1125	11.75	31200	29200	7.80	3.46
TWN030C100A	Y	TXC037E5	Y	N	1125	11.75	31200	29200	8.00	3.46
TWN030C100A	N	TXH033A4	Y	N	1000	11.50	29200	28000	7.55	3.24
TWN036C100B	Y	TDD080R9V3 +TXC036E5	-	N	1125	11.80	38000	36600	8.00	3.38
TWN036C100B	Y	TDD100R9V5 +TXC037E5	-	N	1175	11.85	38500	36600	8.00	3.46
TWN036C100B	Y	TDD100R9V5 +TXC054E5	-	N	1175	11.85	38000	37000	8.00	3.48
TWN036C100B	Y	TUD100R9V5 +TXC037E5	-	N	1200	11.85	38500	36800	8.00	3.44
TWN036C100B	Y	TUD100R9V5 +TXC054E5	-	N	1200	11.85	38000	37000	8.00	3.48
TWN036C100B	Y	TUY100R9V4A +TXC037S3	-	N	1175	11.90	38500	36600	8.00	3.42



Ratings with Auxiliary Devices

COMBINATIONS WITH FAN DELAY RELAY KIT AND/OR TXV KIT AND/OR INSULATION KIT

*When models are matched with an indoor air handler or coil that has a flow control check valve or expansion valve flow control, the addition of an indoor fan delay relay and/or TXV kit may increase the system SEER. The addition of a BAYINS001 kit on the outdoor unit may increase the system HSPF. See charts below for ratings.

OUTDOOR MODEL	INS KIT	INDOOR MODEL	FAN DELAY KIT	TXV KIT	CFM	SEER	COOLING CAPACITY	HI-TEMP HEATING	HSPF	HI-TEMP COP
TWN036C100B	Y	TWE042C14	-	N	1200	11.00	36200	36800	7.50	3.18
TWN036C100B	Y	TWV030B14	-	N	1125	11.00	35800	36600	7.50	3.14
TWN036C100B	N	TXA036C4	Y	N	1200	11.35	36400	36800	7.50	3.22
TWN036C100B	N	TXA037C4	Y	N	1200	11.35	36400	36800	7.50	3.22
TWN036C100B	N	TXA042C4	Y	N	1250	11.50	37000	37200	7.55	3.28
TWN036C100B	N	TXA043C4	Y	N	1350	11.50	37400	37600	7.55	3.32
TWN036C100B	N	TXA050C4	Y	N	1350	11.55	38000	38000	7.65	3.38
TWN036C100B	N	TXA050C4	N	Y	1350	11.75	37800	38000	7.65	3.38
TWN036C100B	N	TXC031E5	Y	N	1100	11.65	36600	36400	7.50	3.20
TWN036C100B	N	TXC036C4	Y	N	1200	11.35	36400	36800	7.50	3.22
TWN036C100B	N	TXC036E5	Y	N	1200	11.90	37800	37400	7.60	3.34
TWN036C100B	N	TXC037C4	Y	N	1200	11.35	36400	36800	7.50	3.22
TWN036C100B	N	TXC037E5	Y	N	1200	11.90	37800	37400	7.60	3.34
TWN036C100B	N	TXC042C4	Y	N	1250	11.50	37000	37200	7.55	3.28
TWN036C100B	N	TXC043C4	Y	N	1350	11.50	37400	37600	7.55	3.32
TWN036C100B	N	TXC050C4	Y	N	1350	11.55	38000	38000	7.65	3.38
TWN036C100B	N	TXC050C4	N	Y	1350	11.75	37800	38000	7.65	3.38
TWN036C100B	N	TXC054E5	Y	N	1350	11.75	38000	38000	7.75	3.42
TWN036C100B	Y	TXC054E5	Y	N	1350	11.75	38000	38000	8.00	3.42
TWN036C100B	N	TXH041A4	Y	N	1350	11.90	38000	37600	7.55	3.32
TWN042C100A	Y	TWE048C14-B	-	N	1550	11.05	42000	42000	8.00	3.32
TWN042C100A	Y	TWE060C15-C TWE060D15-A	-	N	1555	10.10	41000	42500	8.00	3.32
TWN042C100A	N	TXA042C4	Y	N	1250	11.30	40000	40500	7.85	3.28
TWN042C100A	Y	TXA042C4	Y	N	1250	11.30	40000	40500	8.00	3.28
TWN042C100A	N	TXA043C4	Y	N	1400	11.25	40500	41000	7.90	3.32
TWN042C100A	Y	TXA043C4	Y	N	1400	11.25	40500	41000	8.00	3.32
TWN042C100A	N	TXA048C4	Y	N	1350	11.50	41000	41000	8.00	3.38
TWN042C100A	N	TXA049C4	Y	N	1545	11.35	42000	42000	8.10	3.44
TWN042C100A	N	TXA050C4	Y	N	1545	11.40	42000	42000	8.10	3.44
TWN042C100A	N	TXA050C4	N	Y	1545	11.50	42000	42000	8.00	3.44
TWN042C100A	N	TXC036E5	Y	N	1275	11.70	41500	41000	8.00	3.36
TWN042C100A	N	TXC037E5	Y	N	1350	11.70	42000	41000	8.00	3.38
TWN042C100A	N	TXC042C4	Y	N	1250	11.30	40000	40500	7.85	3.28
TWN042C100A	Y	TXC042C4	Y	N	1250	11.30	40000	40500	8.00	3.28
TWN042C100A	N	TXC043C4	Y	N	1400	11.25	40500	41000	7.90	3.32
TWN042C100A	Y	TXC043C4	Y	N	1400	11.25	40500	41000	8.00	3.32
TWN042C100A	N	TXC048C4	Y	N	1350	11.50	41000	41000	8.00	3.38
TWN042C100A	N	TXC049C4	Y	N	1545	11.35	42000	42000	8.10	3.44
TWN042C100A	N	TXC050C4	Y	N	1545	11.40	42000	42000	8.10	3.44
TWN042C100A	N	TXC050C4	N	Y	1545	11.50	42000	42000	8.00	3.44
TWN042C100A	N	TXC054E5	Y	N	1555	11.55	42500	42000	8.10	3.48
TWN042C100A	N	TXH041A4	Y	N	1400	11.60	41500	41000	7.90	3.32
TWN042C100A	N	TXH054A4	Y	N	1575	11.85	44000	42500	8.20	3.52



Ratings with Auxiliary Devices

COMBINATIONS WITH FAN DELAY RELAY KIT AND/OR TXV KIT AND/OR INSULATION KIT

*When models are matched with an indoor air handler or coil that has a flow control check valve or expansion valve flow control, the addition of an indoor fan delay relay and/or TXV kit may increase the system SEER. The addition of a BAYINS001 kit on the outdoor unit may increase the system HSPF. See charts below for ratings.

OUTDOOR MODEL	INS KIT	INDOOR MODEL	FAN DELAY KIT	TXV KIT	CFM	SEER	COOLING CAPACITY	HI-TEMP HEATING	HSPF	HI-TEMP COP
TWN048C100A	Y	TWE060C15-C TWE060D15-A	-	N	1800	10.75	49000	48500	8.00	3.24
TWN048C100A	N	TXA048C4	Y	N	1350	11.35	46000	46000	7.85	3.24
TWN048C100A	Y	TXA048C4	Y	N	1350	11.35	46000	46000	8.00	3.24
TWN048C100A	N	TXA049C4	Y	N	1600	11.30	47500	47000	8.00	3.30
TWN048C100A	N	TXA050C4	Y	N	1600	11.35	47500	47000	8.00	3.30
TWN048C100A	N	TXA050C4	N	Y	1600	11.35	47000	47000	7.85	3.30
TWN048C100A	N	TXA060C5	Y	N	1700	11.50	48500	47500	8.05	3.36
TWN048C100A	N	TXC048C4	Y	N	1350	11.35	46000	46000	7.85	3.24
TWN048C100A	Y	TXC048C4	Y	N	1350	11.35	46000	46000	8.00	3.24
TWN048C100A	N	TXC049C4	Y	N	1600	11.30	47500	47000	8.00	3.30
TWN048C100A	N	TXC050C4	Y	N	1600	11.35	47500	47000	8.00	3.30
TWN048C100A	N	TXC050C4	N	Y	1600	11.35	47000	47000	7.85	3.30
TWN048C100A	N	TXC054E5	Y	N	1700	11.50	48500	47500	8.05	3.36
TWN048C100A	N	TXC060C5	Y	N	1700	11.50	48500	47500	8.05	3.36
TWN048C100A	N	TXH041A4	Y	N	1575	11.80	48500	46500	7.85	3.22
TWN048C100A	N	TXH054A4	Y	N	1600	11.90	50500	47500	8.10	3.40
TWN060C100A	N	TXA060C5	Y	N	1700	11.00	58000	58000	8.00	3.08
TWN060C100A	N	TXC060C5	Y	N	1700	11.00	58000	58000	8.00	3.08

Electrical Data

SCHEMATIC DIAGRAMS (SEE LEGEND)

TWN018C100B

TWN024C100A

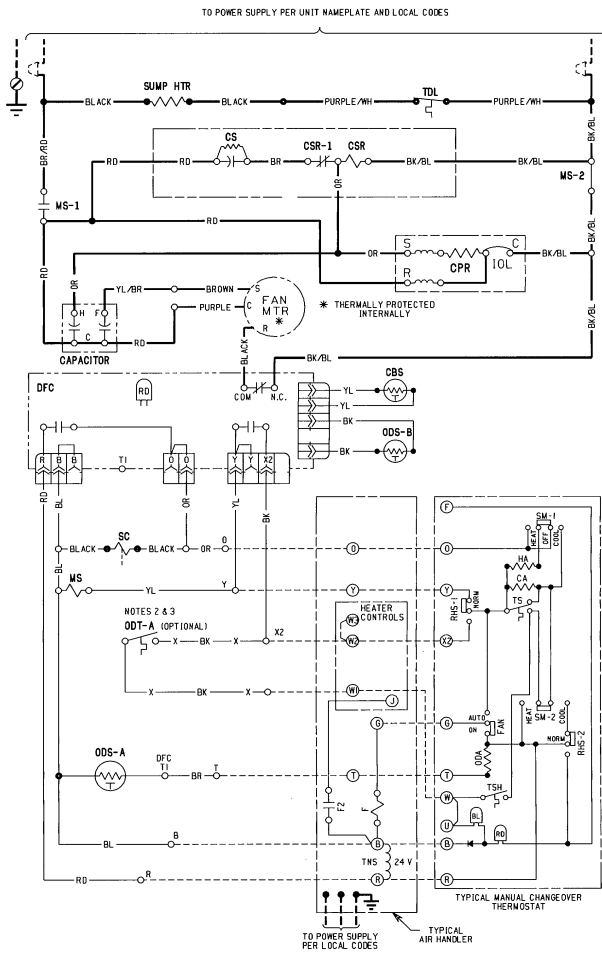

NOTES:

1. LOW VOLTAGE (24 V) FIELD WIRING MUST BE 18 A.W.G. MIN.
2. IF ODT-A IS NOT USED MAKE NO CONNECTIONS TO BK LEADS AT OD UNIT AND ADD JUMPER BETWEEN W1 & W2 AT AIR HANDLER.
3. OPTIONAL ODT NOT AVAILABLE IN ALL MODELS.

<p>⚠ WARNING HAZARDOUS VOLTAGE! DISCONNECT ALL ELECTRIC POWER INCLUDING REMOTE DISCONNECTS BEFORE SERVICING. FAILURE TO DISCONNECT POWER BEFORE SERVICING CAN CAUSE SEVERE PERSONAL INJURY OR DEATH!</p>	<p>⚠ CAUTION USE COPPER CONDUCTORS ONLY! UNIT TERMINALS ARE NOT DESIGNED TO ACCEPT OTHER TYPES OF CONDUCTORS. FAILURE TO DO SO MAY CAUSE DAMAGE TO THE EQUIPMENT!</p>
---	--

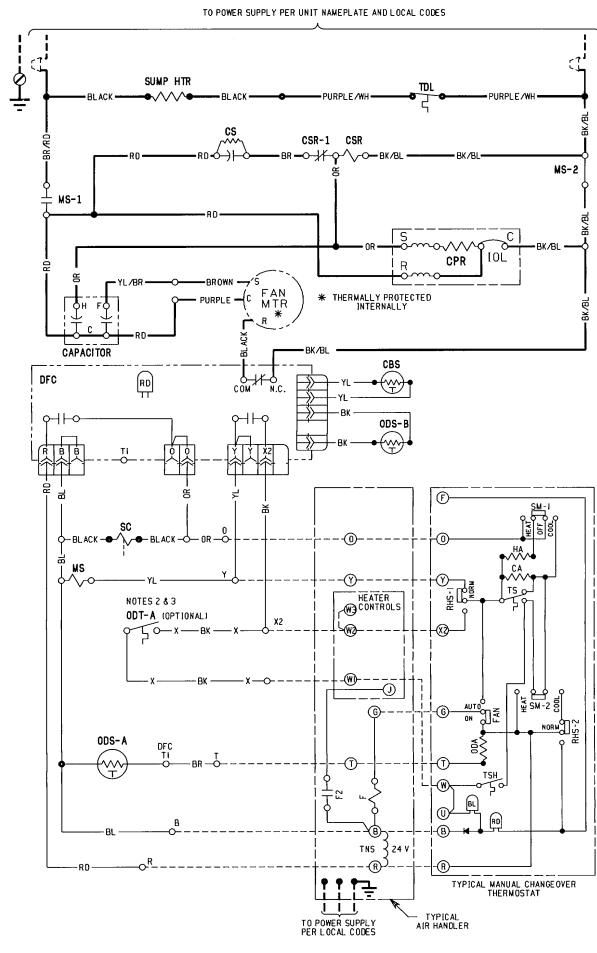

NOTES:

1. LOW VOLTAGE (24 V) FIELD WIRING MUST BE 18 A.W.G. MIN.
2. IF ODT-A IS NOT USED MAKE NO CONNECTIONS TO BK LEADS AT OD UNIT AND ADD JUMPER BETWEEN W1 & W2 AT AIR HANDLER.
3. OPTIONAL ODT NOT AVAILABLE IN ALL MODELS.

<p>⚠ WARNING HAZARDOUS VOLTAGE! DISCONNECT ALL ELECTRIC POWER INCLUDING REMOTE DISCONNECTS BEFORE SERVICING. FAILURE TO DISCONNECT POWER BEFORE SERVICING CAN CAUSE SEVERE PERSONAL INJURY OR DEATH!</p>	<p>⚠ CAUTION USE COPPER CONDUCTORS ONLY! UNIT TERMINALS ARE NOT DESIGNED TO ACCEPT OTHER TYPES OF CONDUCTORS. FAILURE TO DO SO MAY CAUSE DAMAGE TO THE EQUIPMENT!</p>
---	--

Electrical Data

SCHEMATIC DIAGRAM (SEE LEGEND)

TWN036C100B, TWN030-060C100A

LEGEND

— COLOR OF WIRE
 BK/BL BLACK WIRE WITH BLUE MARKER
 — COLOR OF MARKER
 BK BLACK OR ORANGE YL YELLOW
 BL BLUE RD RED GR GREEN
 BR BROWN WH WHITE PR PURPLE

SYMBOLS

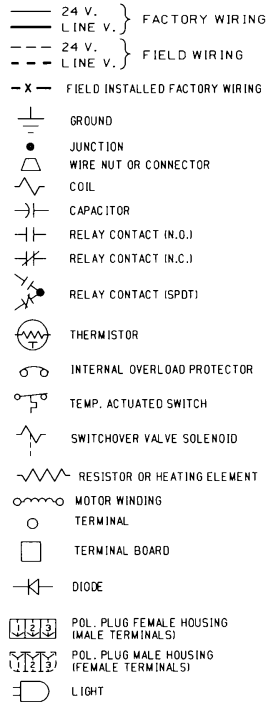

CA COOLING ANTICIPATOR	MS COMPRESSOR MOTOR CONTACTOR
CBS COIL BOTTOM SENSOR	ODA OUTDOOR ANTICIPATOR
CF FAN CAPACITOR	OFT OUTDOOR FAN THERMOSTAT
CN WIRE CONNECTOR	ODS OUTDOOR TEMPERATURE SENSOR
CPR COMPRESSOR	ODT OUTDOOR THERMOSTAT
CR RUN CAPACITOR	RHS RESISTANCE HEAT SWITCH
CS STARTING CAPACITOR	SC SWITCHOVER VALVE SOLENOID
CSR CAPACITOR SWITCHING RELAY	SM SYSTEM "ON-OFF" SWITCH
DFC DEFROST CONTROL	TDL DISCHARGE LINE THERMOSTAT
HA HEATING ANTICIPATOR	TNS TRANSFORMER
IOL INTERNAL OVERLOAD PROTECTOR	TS HEATING-COOLING THERMOSTAT
	TSH HEATING THERMOSTAT

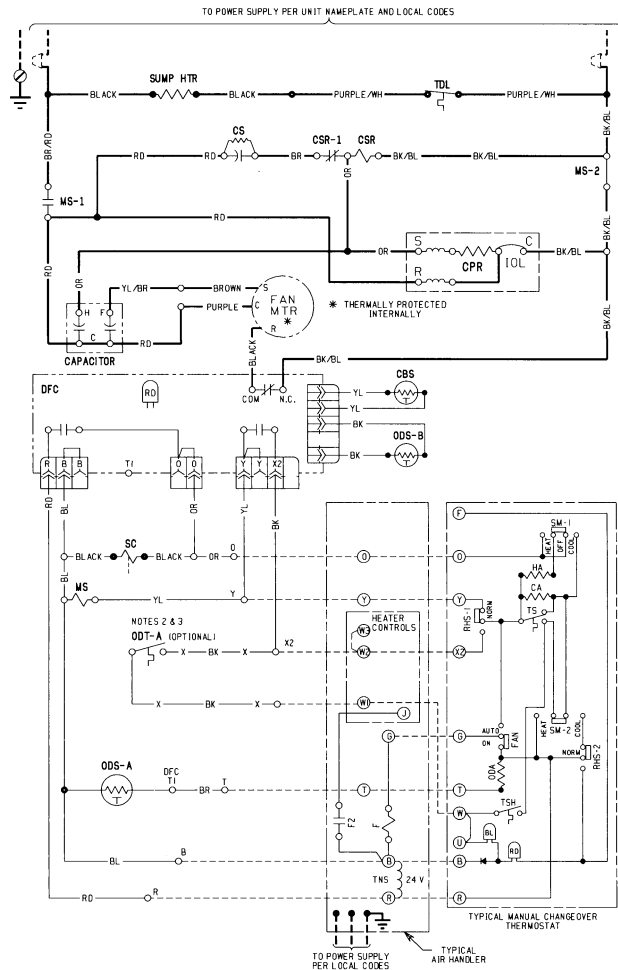

- NOTES:
1. LOW VOLTAGE (24 V) FIELD WIRING MUST BE 18 A.W.G. MIN.
 2. IF ODT-A IS NOT USED MAKE NO CONNECTIONS TO BK LEADS AT OD UNIT AND ADD JUMPER BETWEEN W1 & W2 AT AIR HANDLER.
 3. OPTIONAL ODT NOT AVAILABLE IN ALL MODELS.

<p>⚠ WARNING HAZARDOUS VOLTAGE ! DISCONNECT ALL ELECTRIC POWER INCLUDING REMOTE DISCONNECTS BEFORE SERVICING. FAILURE TO DISCONNECT POWER BEFORE SERVICING CAN CAUSE SEVERE PERSONAL INJURY OR DEATH!</p>	<p>⚠ CAUTION USE COPPER CONDUCTORS ONLY! UNIT TERMINALS ARE NOT DESIGNED TO ACCEPT OTHER TYPES OF CONDUCTORS. FAILURE TO DO SO MAY CAUSE DAMAGE TO THE EQUIPMENT!</p>
--	--

Dimensions

TWN018-060C OUTLINE DRAWING

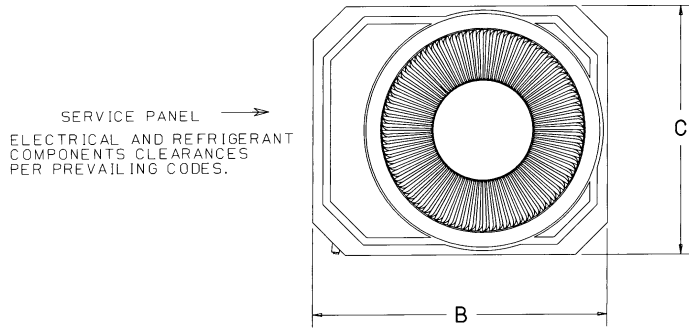

NOTE: ALL DIMENSIONS ARE IN MM (INCHES).

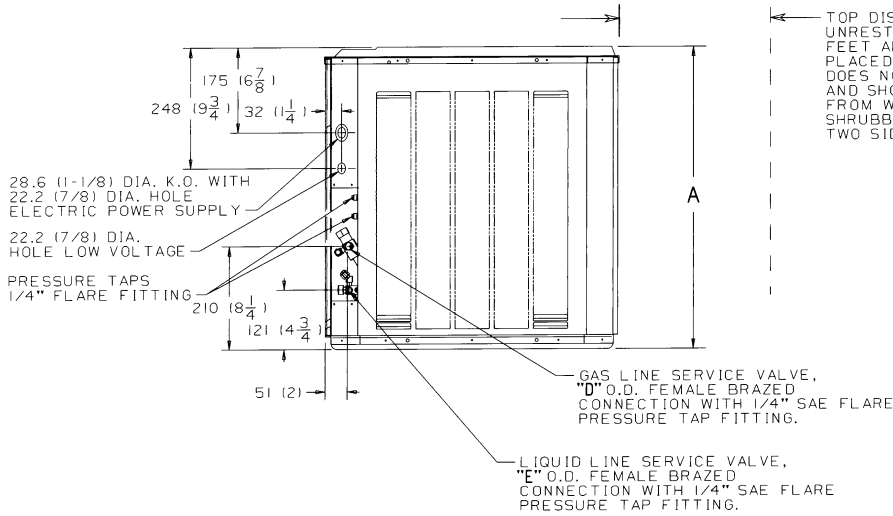

TOP DISCHARGE AREA SHOULD BE UNRESTRICTED FOR AT LEAST FIVE (5) FEET ABOVE UNIT. UNIT SHOULD BE PLACED SO ROOF RUN-OFF WATER DOES NOT POUR DIRECTLY ON UNIT, AND SHOULD BE AT LEAST 305 (12") FROM WALL AND ALL SURROUNDING SHRUBBERY ON TWO SIDES. OTHER TWO SIDES UNRESTRICTED.

FIG. 1

MODELS	FIG.	A	B	C	D	E
TWN018C-B	1	619 (24-3/8)	718 (28-1/4)	625 (24-5/8)	5/8	1/4
TWN024C-A	2	727 (28-5/8)	835 (32-7/8)	730 (28-3/4)	3/4	5/16
TWN030C-A	2	832 (32-3/4)	835 (32-7/8)	730 (28-3/4)	3/4	5/16
TWN036C-B	2	940 (37)	987 (38-7/8)	883 (34-3/4)	7/8	3/8
TWN042C-A	2	940 (37)	987 (38-7/8)	883 (34-3/4)	7/8	3/8
TWN048C-A	2	940 (37)	987 (38-7/8)	883 (34-3/4)	1-1/8	3/8
TWN060C-A	2	1137 (44-3/4)	987 (38-7/8)	883 (34-3/4)	1-1/8	3/8

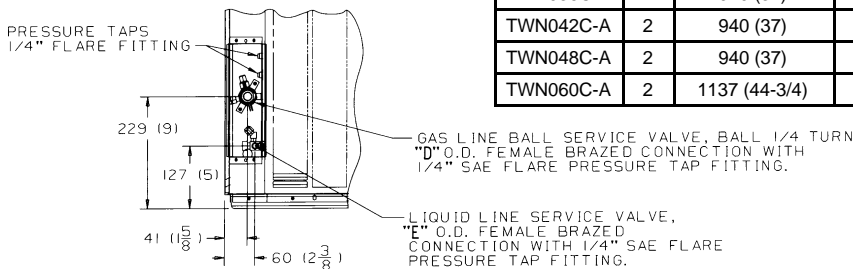

FIG. 2

From Dwg. 21D147562 Rev. 5



Mechanical Specification Options

General

This unit is fully charged from the factory for up to 25 feet of piping. This unit is designed to operate at outdoor ambient temperatures as high as 115°F. Cooling capacities matched with a wide selection of air handlers and furnace coils that are A.R.I. certified. The unit is UL listed. Exterior is designed for outdoor application.

Casing

Unit casing is constructed of heavy gauge, galvanized steel and painted with a weather-resistant powder paint.

Refrigerant Controls

Refrigeration system controls include condenser fan and compressor contactor. High and low pressure controls are inherent to the compressor. A factory installed liquid line drier is standard.

Compressor

The Climatuff® compressor features a 5 year limited warranty, internal over temperature and pressure protection, total epoxy dipped hermetic motor windings, and thermostatically controlled sump heater. Other features include: roto lock suction and discharge refrigerant connections, centrifugal oil pump, "special steel alloy" valves in valve plate assembly, and internal spring mounts to reduce vibration and noise.

Condenser Coil

The outdoor coil provides low airflow resistance and efficient heat transfer. The coil is protected on all four sides by louvered panels and has a 5 year limited warranty.

Low Ambient Cooling

As manufactured, this unit has a cooling capability when applied with the following indoor refrigerant control: FCCV to 55°F, TXV to 45°F. The addition of an evaporator defrost control permits operation when applied with the following indoor refrigerant control: FCCV to 40° F., TXV to 30°F.

Accessories

Thermostats — Cooling only and heat/cooling (manual and automatic changeover). Sub-base to match thermostat and locking thermostat cover.

Evaporator Defrost Control — See Low Ambient Cooling.



TRANE™

The Trane Company
Unitary Products Group
6200 Troup Highway
Tyler, TX 75707

An American-Standard Company

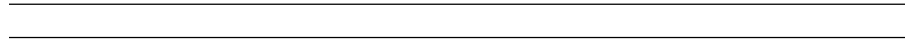

Since the Trane Company has a policy of continuous product improvement, it reserves the right to change the specifications and design without notice.