

Convertible Variable Speed – Air Handlers 3.5 - 5 Ton

2/4TEE3F39A1000A

2/4TEE3F48A1000A

2/4TEE3F64A1000A

⚠ WARNING: HAZARDOUS VOLTAGE - DISCONNECT POWER BEFORE SERVICING

ALL phases of this installation must comply with NATIONAL, STATE AND LOCAL CODES

IMPORTANT — This Document is **customer property** and is to remain with this unit. Please return to service information pack upon completion of work.

A. GENERAL INFORMATION

⚠ WARNING

THIS INFORMATION IS FOR USE BY INDIVIDUALS HAVING ADEQUATE BACKGROUNDS OF ELECTRICAL AND MECHANICAL EXPERIENCE. ANY ATTEMPT TO REPAIR A CENTRAL AIR CONDITIONING PRODUCT MAY RESULT IN PERSONAL INJURY AND/OR PROPERTY DAMAGE. THE MANUFACTURER OR SELLER CANNOT BE RESPONSIBLE FOR THE INTERPRETATION OF THIS INFORMATION, NOR CAN IT ASSUME ANY LIABILITY IN CONNECTION WITH ITS USE.

⚠ CAUTION

To prevent shortening its service life, the air handler should not be used during the finishing phases of construction. The low return air temperatures can lead to the formation of condensate. Condensate in the presence of chlorides and fluorides from paint, varnish, stains, adhesives, cleaning compounds, and cement creates a corrosive condition which may cause rapid deterioration of the cabinet and internal components.

These instructions do not cover all variations in systems or provide for every possible contingency. Should further information be desired or particular problems arise which are not covered sufficiently by this manual, contact your local distributor or the manufacturer as listed on the air handler nameplate.

These Air Handlers are shipped from the factory in the upflow or horizontal right configuration and are fully convertible to downflow or horizontal left. Refer to Section C beginning on page 3 for additional information.

INSPECTION

Check carefully for any shipping damage. This must be reported to and claims made against the transportation company immediately. Check to be sure all major components are in the unit. Any missing parts should be reported to your supplier at once, and replaced with authorized parts only.

⚠ CAUTION

Cardboard packing material must be removed from inside the blower assembly before starting the unit. Failure to do so may cause indoor blower motor failure.

CONTENTS

| | |
|--|----|
| General Information | 1 |
| Installation Limitations & Recommendations | 1 |
| Two Piece Cabinet Disassembly | 3 |
| Unit Installation | 3 |
| Vertical Upflow | 3 |
| Vertical Downflow | 4 |
| Horizontal Left | 7 |
| Horizontal Right | 8 |
| Refrigerant Piping | 8 |
| Condensate Drain Piping | 9 |
| Electrical - Wiring | 10 |
| Airflow Adjustment | 11 |
| Hook Up Diagrams | 12 |
| Outline Drawings | 14 |
| Checkout Procedures | 16 |

NOTE: *Version française sur la page 17.*

INSTALLATION LIMITATIONS & RECOMMENDATIONS

The general location of the air handler is normally selected by the architect, contractor and/or home owner for the most effective application and satisfaction.

NOTE: *Condensation may occur on the surface of the air handler when installed in an unconditioned location. When units are installed in unconditioned spaces, verify that all electrical and refrigerant line penetrations on the air handler are sealed completely.*

These air handlers are suitable for installation in a closet, alcove or utility room with free, non-ducted, air return, using the area space as a return air plenum. With ducted supply air, if the minimum clearances to combustible materials and service access are observed, the above installations are suitable.

This area may also be used for other purposes, including an electric hot water heater - **but in no case shall a fossil fuel device be installed and/or operated in the same closet, alcove or utility room.**

Installer's Guide

AIR HANDLER SUB-BASE

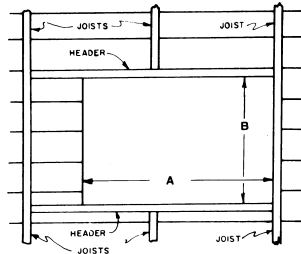

| FLOOR OPENING - SIZE | | |
|----------------------|--------|----------|
| MODEL NO. | A | B |
| TAYBASE100 | 23-3/4 | 14-13/16 |
| TAYBASE101 | 21-3/4 | 14-13/16 |
| TAYBASE102 | 26-3/4 | 14-13/16 |

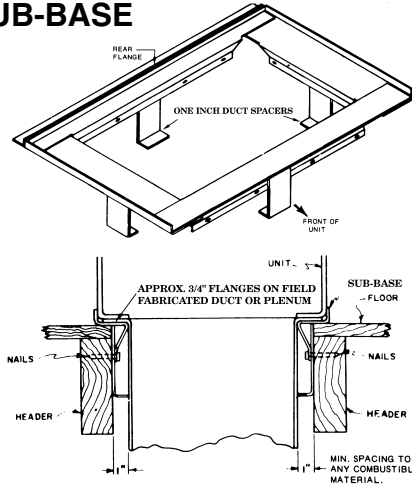

Figure 1

In addition, these air handlers are suitable for installation in an attic, garage or crawl space with ducted supply and return air.

This equipment has been evaluated in accordance with the Code of Federal Regulations, Chapter XX, Part 3280 or the equivalent. "SUITABLE FOR MOBILE HOME USE"

For proper installation the following items must be considered:

1. If adequate power is available and correct according to nameplate specifications.
2. Insulate all ducts, particularly if unit is located outside of the conditioned space.
3. Pursuant to Florida Building Code 13-610.2.A.2.1, this unit meets the criteria for a factory sealed air handler.
4. To ensure maximum efficiency and system performance, the existing supply and return duct system static pressures must not exceed the total available static pressure of the air handler. Reference ACCA Manual D, Manual S and Manual RS along with the air handler Product Data and Service Facts for additional information.
5. It is recommended that the outline drawing be studied and dimensions properly noted and checked against selected installation site. By noting in advance which knockouts are to be used, proper clearance allowances can be made for installation and possible future service.
6. When the air handler with supplementary heater is to be installed in the downflow position on combustible flooring an accessory sub-base (TAYBASE100 for 2/4TEE3F39-64) must be used. See Figure 1.
7. If supplementary heat is to be added, power supply must be sufficient to carry the load. In addition, minimum air flow settings, unit and duct clearances to combustible material must be maintained as stated on the air handler rating nameplate.

CAUTION

For air handlers not equipped with a factory installed electric heater, a field installed heater is available from American Standard Inc. Only heaters built by American Standard Inc. are approved for use in the air handler. These heaters have been designed and tested in accordance with UL standards to provide safe and reliable operation. A list of approved heaters is provided on the air handler rating nameplate. Heaters that are not factory approved could cause damage and are not covered under equipment warranty.

NOTE: If air handler is used **WITHOUT** a supplementary electric heater, a sheetmetal plate is required to cover the open hole in the airflow system (See Figure 2). In addition, ensure that the cabinet is sealed air tight where the field wires enter the unit.

IF AIRHANDLER IS USED **WITHOUT** A FACTORY FURNISHED SUPPLEMENTARY HEATER, A PLATE IS REQUIRED TO COVER THE OPEN HOLE IN THE AIR FLOW SYSTEM

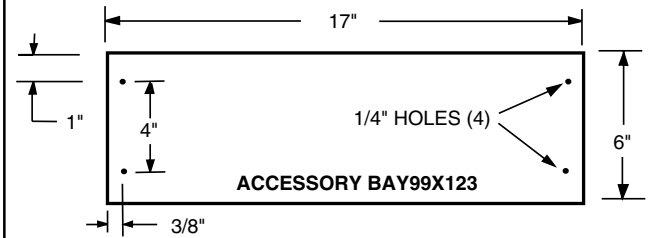

Figure 2 From Dwg. 21B140413

8. If the unit is installed without a return air duct, applicable local codes may limit this air handler to installation only in a single story residence & within conditioned space.
9. If the outdoor unit is to be installed later, or by others, then installation of the air handler must be made to allow access for refrigerant lines, or attach refrigerant lines to air handler when installing.

10. Make sure there are provisions for installing condensate drain lines.
11. If side, front or rear return is required, air handler must be elevated or placed on a plenum (TAYPLNM100). Connecting return duct directly to the side, front or rear of the cabinet is not approved.
12. Route refrigerant & condensate drain lines away from air handler so they do not interfere with access panels and filters.
13. When external accessories are used, the additional height and width requirements must be considered in the overall space needed.
14. These units are not approved for outdoor installation.
15. These units are approved for draw-through application only.

16. Flow-through Bypass Humidifiers

Excessive bypass air may cause water blow-off, which will adversely affect system operation and air cleaner performance. To verify bypass airflow, follow the Bypass Humidifier Pre-Installation Check-out and Set-Up Procedures available through your local distributor. Ask for publication number 18-CH37D1-1.

Steam and Flow-through Fan Power Duct-mounted Humidifiers

Follow the humidifier installation instructions. These should only be installed on the supply air side of the system.

B. Two Piece Cabinet Disassembly (OPTIONAL)

NOTE: For easier installation into tight areas, the 4 and 5 ton air handlers can be disassembled and reassembled after moved to an attic or other space.

Steps for disassembly and reassembly (See Figures 3 and 4)

1. Disconnect wiring.
2. Remove center bracket.
3. Remove blower assembly.
4. Remove coil.
5. Cut foil tape - minimum 3" foil tape.
6. Remove top 8 screws. See Figure 3.
7. Lift upper section.
8. Set air handler in place.
9. Attach screws - insure gaskets are aligned along flange.
10. Use foil tape to seal - use minimum 3" foil tape.
11. Insert coil.
12. Reinstall blower assembly.
13. Reinstall center bracket.
14. Reconnect wiring.

NOTE: In Downflow, remove coil before blower by reversing steps 3 and 4.

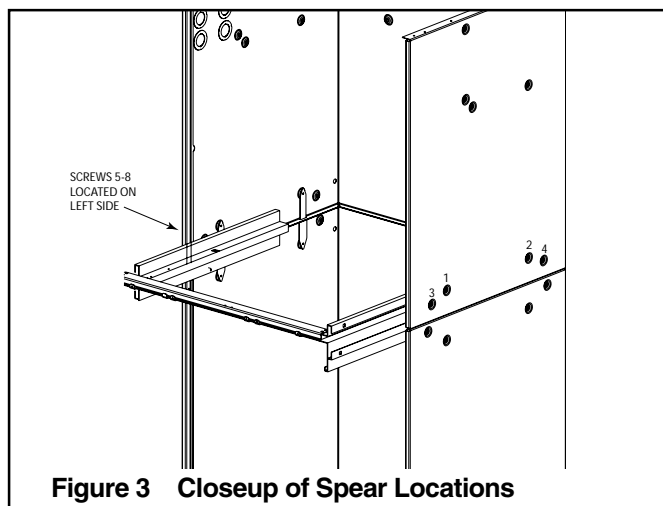

Figure 3 Closeup of Spear Locations

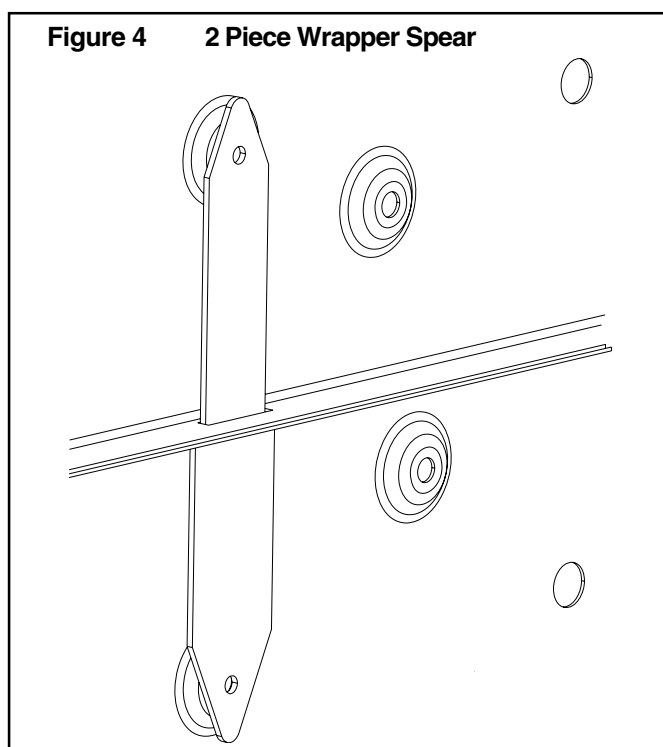

Figure 4 2 Piece Wrapper Spear

C. UNIT INSTALLATION

UPFLOW

- a. **For maximum efficiency**, the horizontal drip tray should be removed. See Figures 5, 6 and 7. Tray removal requires that the coil be removed by sliding the coil out on the coil channel supports. There is a coil support tab at the top of the coil connected to the case must be removed first. Remove 1 inch insulation strip covering the lip of the drip tray. The tray is detached by removing the two screws at the drain pan. Remove the two screws holding the two brackets at the top of the coil. Remove drip tray by gently breaking the seal between the drip tray and drain pan.

Installer's Guide

- b. Remove the factory installed baffle assembly from the apex of the coil by using a 5/16" nutdriver to remove the screw. Replace this baffle with the factory supplied narrow coil baffle using the screws removed previously. See Figure 8. Reinstall coil assembly.

⚠ CAUTION

When installing the narrow coil baffle, make sure to align the baffle up with the holes so NOT to puncture the coil tubing.

- c. Position unit on Pedestal or other suitable foundation. If Pedestal is not used, a frame strong enough to support the total weight must be provided. Provide a minimum height of 14 inches for proper unrestricted airflow.
- d. If a return air duct is connected to the air handler, it must be the same dimensions as shown in the outline drawing on page 14.
- e. Pedestal and unit should be isolated from the foundation using a suitable isolating material.
- f. **Openings where field wiring enters the cabinet must be completely sealed.** Location of power entry is shown on the Outline Drawing. Use 2.5" clear stickers provided to seal all unused electrical knockouts. See Figure 13.
- g. After ductwork connections are made, seal airtight and per Local codes.

DOWNFLOW

- a. **For maximum efficiency**, the horizontal drip tray should be removed. See Figures 5, 6 and 7. Tray removal requires that the coil be removed by sliding the coil out on the coil channel supports. There is a coil support tab at the top of the coil connected to the case must be removed first. Remove 1 inch insulation strip covering the lip of the drip pan. The tray is detached by removing the two screws at the drain pan and the two screws holding the two brackets at the top of the coil. Remove drip tray by gently breaking the seal between the drip tray and drain pan.
- b. Remove the factory installed baffle assembly b. Remove the factory installed baffle assembly from the apex of the coil by using a 5/16" nutdriver to remove the screw. Replace this baffle with the factory supplied narrow coil baffle using the screws removed previously. See Figure 8. Reinstall coil assembly.

⚠ CAUTION

When installing the narrow coil baffle, make sure to align the baffle up with the holes so NOT to puncture the coil tubing.

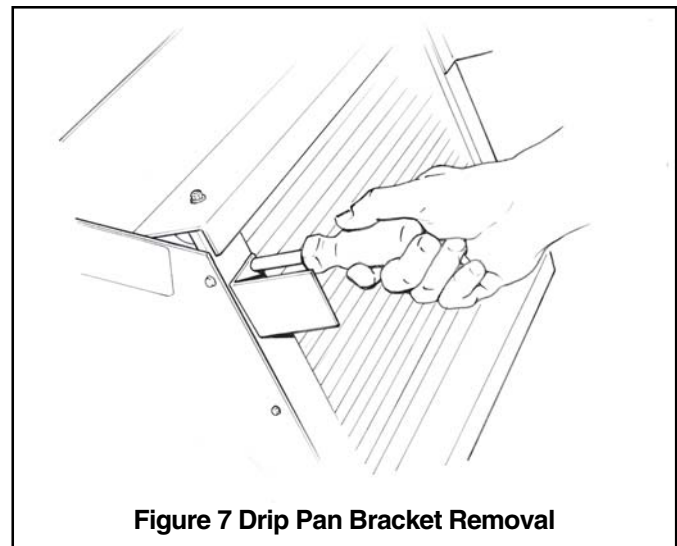
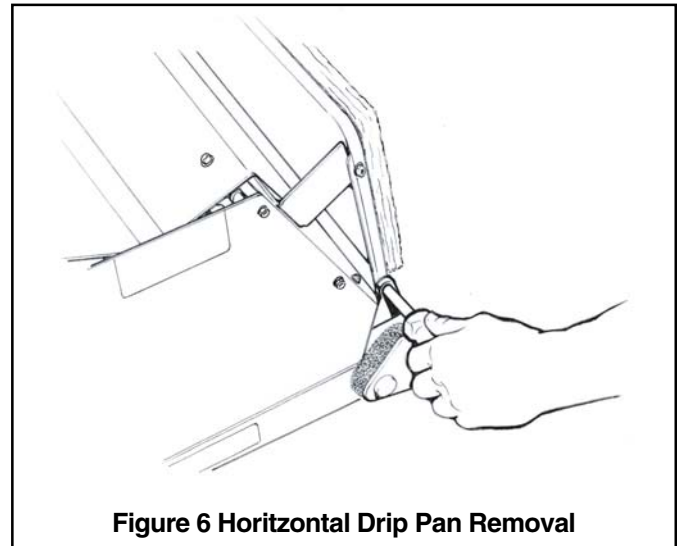
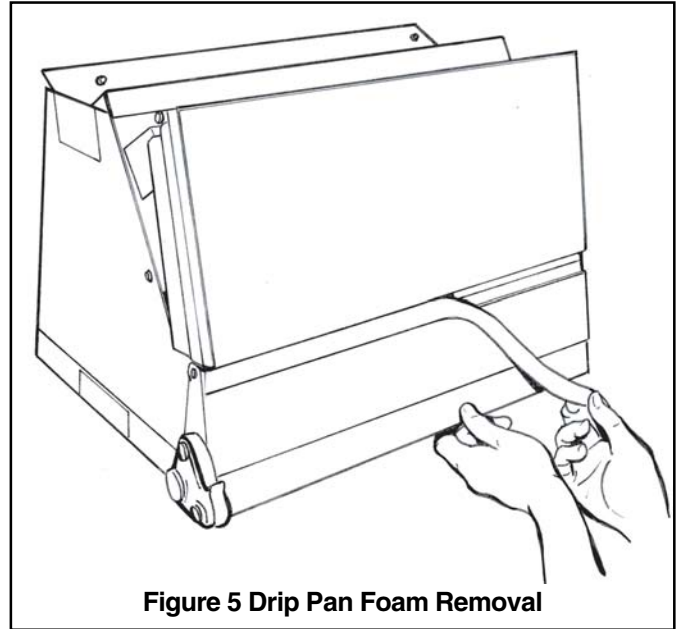

Installer's Guide

NOTE: Installation of the downflow baffle kit included with unit is required on downflow applications. See Figure 9.

- c. Remove front shield by removing screws on right side. Make sure to reinstall front shield after baffle changes. See Figure 9.
- d. Remove the front triangular baffle from the coil and install the 1/2" wide gasket provided per Figure 9. Trim the gasket length to fit the baffle. Reinstall the baffle to coil, with gasket material compressed against the coil.
- e. Install the water blow-off baffles provided on each side of the coil with the flange at the top as shown in Figure 9. The bottom of the baffle is to be as close to the bottom of the coil as possible.
- f. Install the 7/8" wide gasket in each side of the drain pan as shown in Figure 9 (sect. X-X).
- g. The 5 ton model (2/4TEE3D62) requires 2 water diverter baffles to be placed underneath the coil on the inside edge of the drain pan. See Figure 9.

Fill the bend in the baffle which fits the inner edge of the drain pan with RTV type adhesive/sealant before installing the baffle.

- h. The unit is then placed with the blower side down and the coil is replaced on the coil channel supports with the drain connections at the bottom. The unit is now in downflow position with front access. Do not reattach coil support tab.

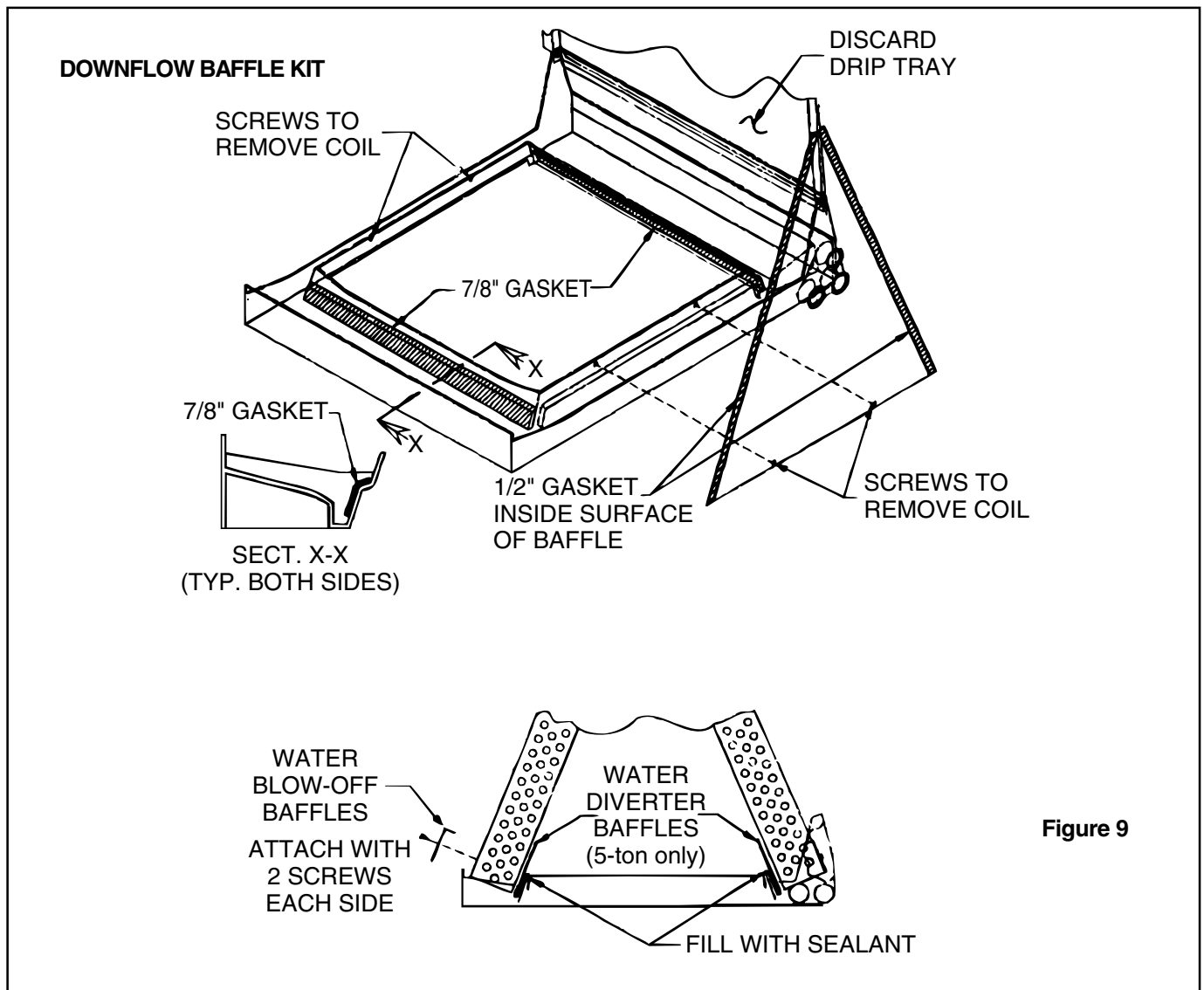
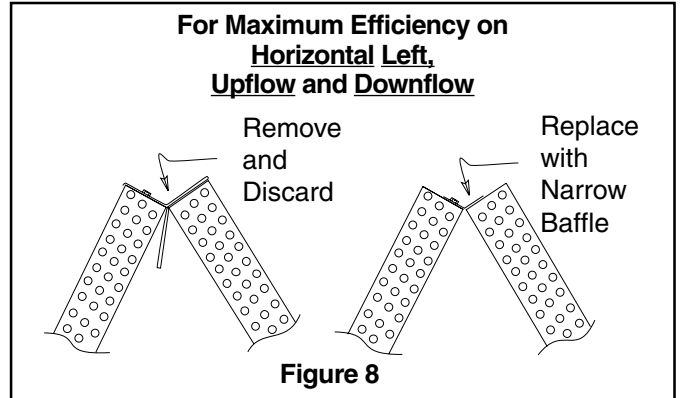

Installer's Guide

Figure 10

FOR DOWNFLOW OR HORIZONTAL LEFT APPLICATIONS:

WHEN INSERTING COIL, TILT COIL FORWARD TO ALLOW DRAINPAN TO CLEAR TABS ON COIL CHANNEL SUPPORTS.

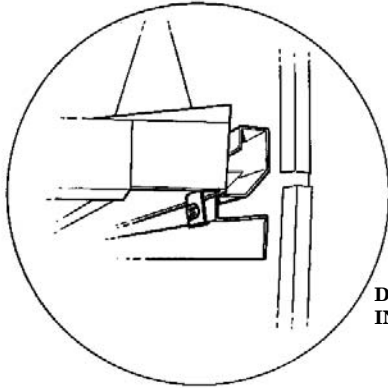

DRAINPAN SHOWN
IN PLACE

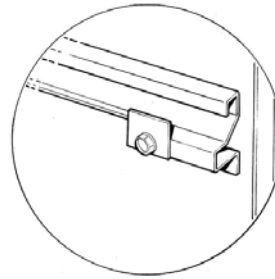

TAB - AS MOUNTED
ON COIL CHANNEL
SUPPORT

Figure 11

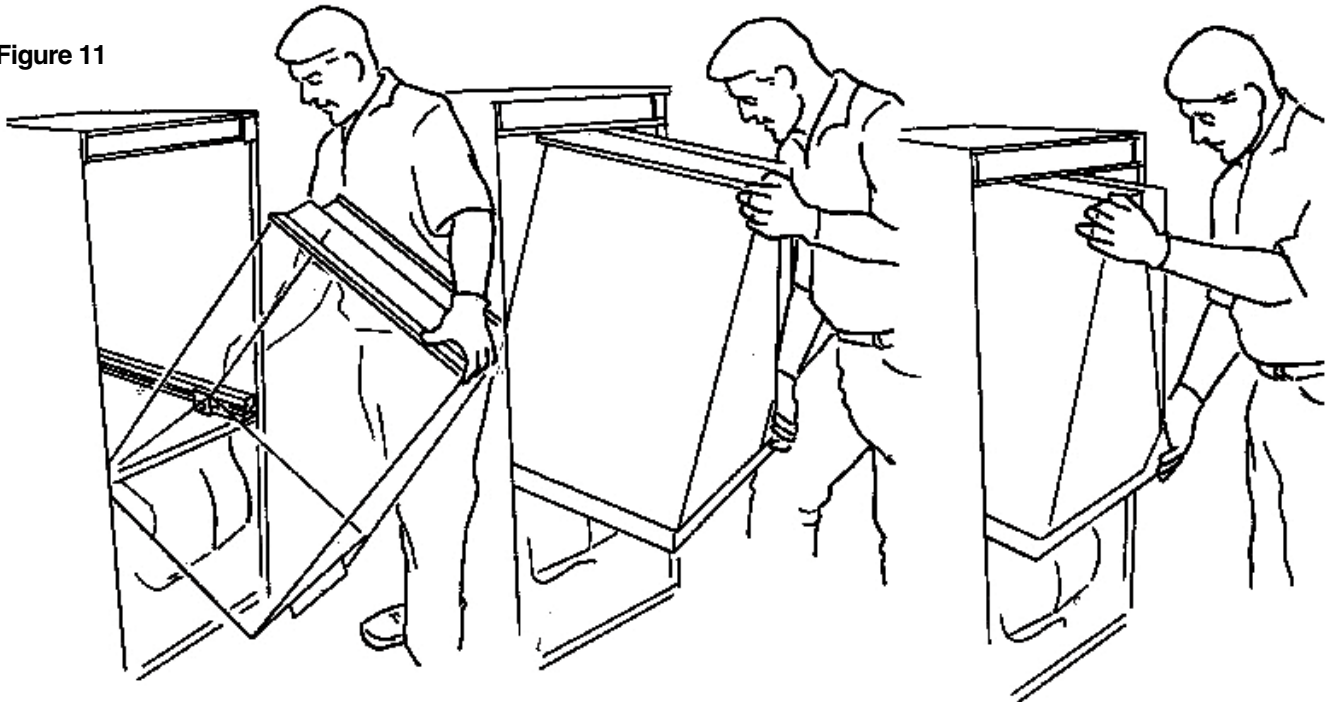

TO REMOVE BLOWER ASSEMBLY WHEN COIL IN PLACE, PRESS UP ON COIL USING THUMBS WHILE PULLING BLOWER FORWARD.

- i. When supplementary heaters are used, accessory subbase (TAYBASE102 for 2/4TEE3F62) must be used. See Figure 1.
- j. If a return duct is connected to the air handler, it must be the same dimensions as the return opening shown in the outline drawing on page 14.
- k. **Openings where field wiring enters the cabinet must be completely sealed.** Location of power entry is shown on the outline drawing.

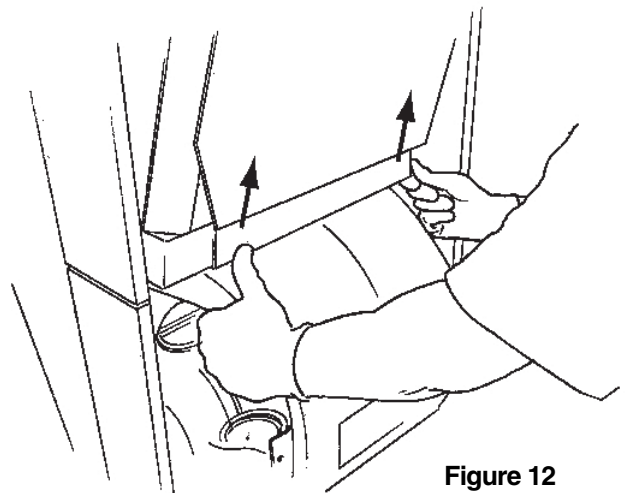

Figure 12

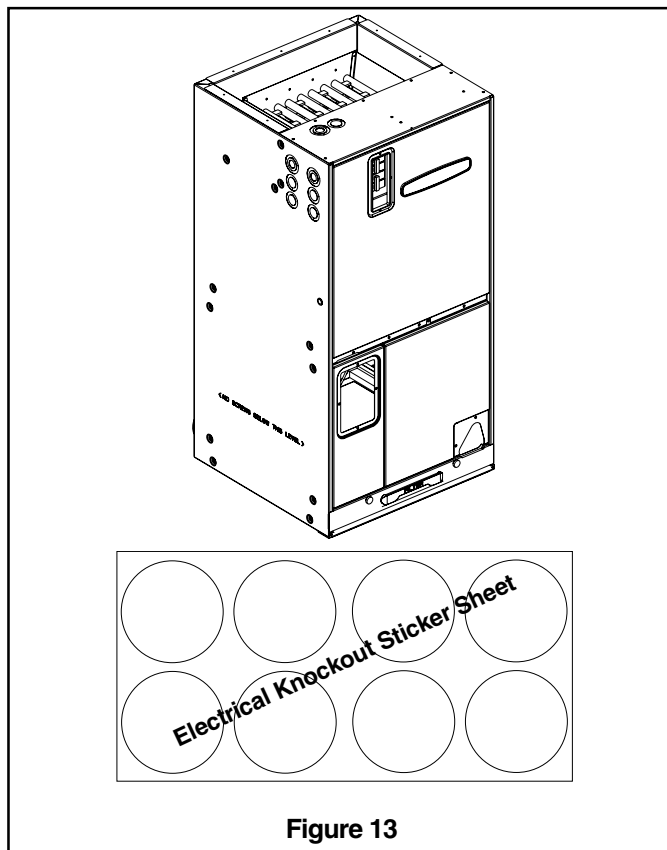

Figure 13

Use 2.5" clear stickers provided to seal all unused electrical knockouts. See Figure 13.

1. After ductwork connections are made, seal airtight and per Local codes.

HORIZONTAL LEFT

- a. **For maximum efficiency** and Customer ease of filter maintenance, it is recommended that a properly sized **remote filter** and grille be installed for horizontal applications. Airflow should not exceed the face velocity of the filter being used. **The factory installed filter should then be removed from the unit.**
- b. To convert the unit to horizontal left, front access, slide the coil out on the coil channel supports and rotate the complete coil 180 degrees.
- c. Remove the factory installed baffle assembly from the apex of the coil by using a 5/16" nutdriver to remove the hex head screw. There is a coil support tab at the top of the coil connected to the case must be removed first. Replace this baffle with the factory supplied narrow coil baffle using the screws removed previously. See Figure 9.
- d. The coil is then inserted back into the cabinet on the opposite side coil channel supports. The unit is now horizontal left with front access. Do not reattach coil support tab.
- e. If the unit is suspended, it must be supported from the bottom near both ends as well as the middle to prevent sagging. The service access

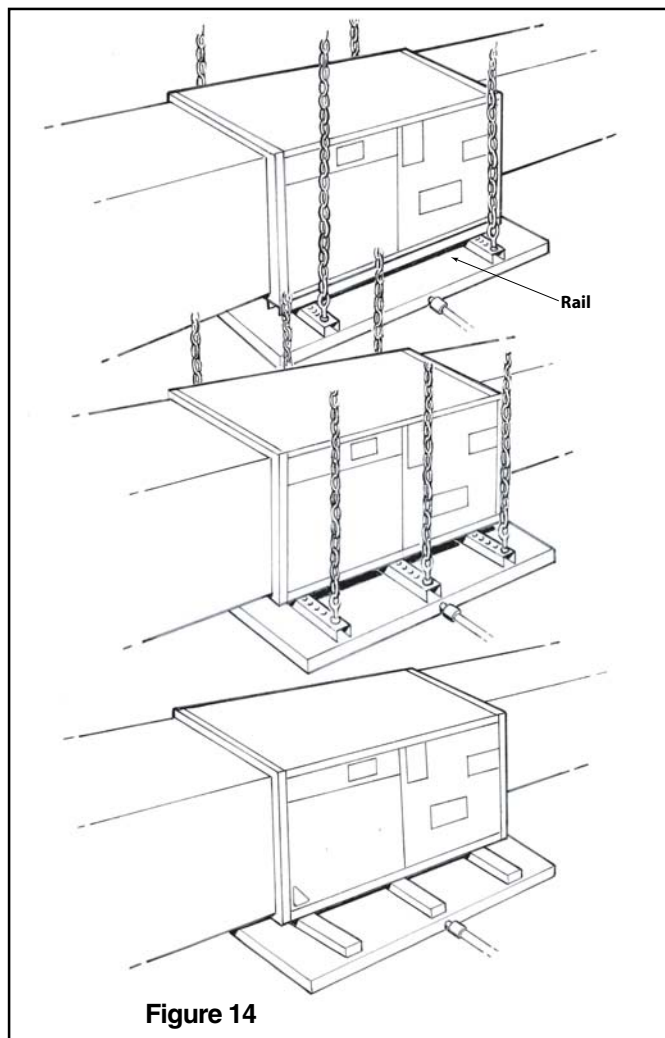

Figure 14

must remain unobstructed. If the unit is supported along the length of the front and back with rails, the air handler only needs to be suspended at both ends. See Figure 14.

If the unit is not suspended it must be supported as mentioned above and isolated carefully to prevent sound transmission. Vibration isolators (purchased locally) must be placed under the unit.

- f. It is always recommended that an auxiliary drain pan be installed under a horizontal air handler (See Condensate Piping) to prevent possible damage to ceilings.
- g. Isolate the auxiliary drain pan from the unit or from the structure.
- h. Connect the auxiliary drain line to a separate drain line (no trap is needed in this line) and terminate according to national and local codes.
- i. If a return duct is connected to the air handler, it must be the same dimensions as the return opening shown in the outline drawing on page 14.
- j. **Openings where field wiring enters the cabinet must be completely sealed.** Location of power entry is shown on the outline drawing.

Use 2.5" clear stickers provided to seal all unused electrical knockouts. See Figure 13.

- k. After ductwork connections are made, seal airtight and per Local codes.

HORIZONTAL RIGHT

- a. **For maximum efficiency** and Customer ease of filter maintenance, it is recommended that a properly sized **remote filter** grille be installed for horizontal applications. Airflow should not exceed the face velocity of the filter being used. **The factory installed filter should then be removed from the unit.**
- b. Unit is shipped from the factory in the upflow or horizontal right configuration. Unit conversion is not required.
- c. If the unit is suspended, it must be supported from the bottom near both ends as well as the middle to prevent sagging. The service access must remain unobstructed. If the unit is supported along the length of the front and back, the air handler only needs to be suspended at both ends. See Figure 14.
- d. If the unit is not suspended it must be isolated carefully to prevent sound transmission. Vibration isolators (purchased locally) must be placed under the unit.
- e. It is always recommended that an auxiliary drain pan be installed under a horizontal air handler (See Condensate Drain Piping) to prevent possible damage to ceilings.
- f. Isolate the auxiliary drain pan from the unit or from the structure.
- g. If a return duct is connected to the air handler, it must be the same dimensions as the return opening shown in the outline drawing on page 14.
- h. If a return duct is connected to the air handler, it must be the same dimensions as the return opening shown in the outline drawings.
- i. **Openings where field wiring enters the cabinet must be completely sealed.** Location of power entry is shown on the outline drawing. Use 2.5" clear stickers provided to seal all unused electrical knockouts. See Figure 13.
- j. After ductwork connections are made, seal airtight and per Local codes.

D. DUCT CONNECTIONS

The supply and return air ducts should be connected to the unit with flame retardant duct connectors.

Convertible duct flanges are provided on the discharge opening to provide a "flush fit" for 3/4" or 1-1/2" duct board applications, see the Outline drawing on page 16 for sizes of the duct connections. After the duct is secured, seal around the supply duct to prevent air leakage.

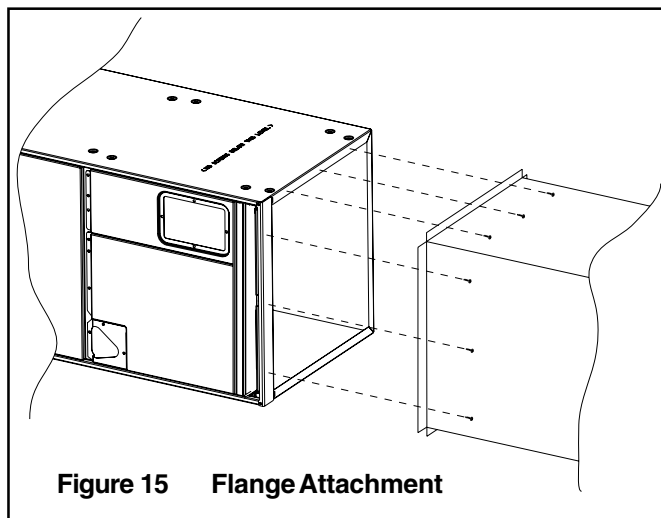

Figure 15 Flange Attachment

NOTE: If the convertible duct flanges are not used, they must be removed and discarded for proper airflow.

E. REFRIGERANT PIPING

IMPORTANT:

Refrigerant piping must be routed to maintain service access to blower compartment and provide easy removal of filter access panel and filter.

NOTE: Penetration around the Refrigerant lines must be sealed and Electrical inlets need to be sealed at both the low and the high voltage.

1. Refrigerant connections are made outside the cabinet.
2. Installation of refrigerant lines is covered in the installation instructions packaged with the outdoor unit. Evacuation, leak testing and brazing procedures are included in those instructions. Read those instructions before starting installation of refrigerant lines.

NOTE: TXV Equipped is Non-Bleed, and may require a start kit on the outdoor unit.

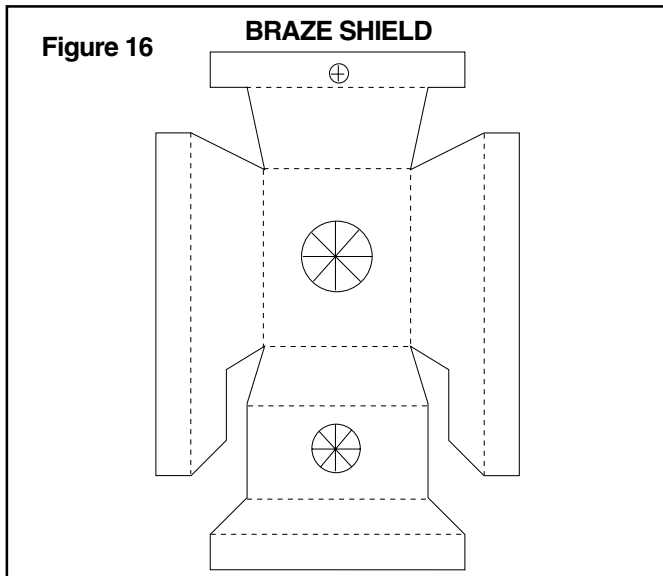

Figure 16

BRAZE SHIELD

F. BRAZING TO EVAPORATOR SECTION

NOTE: A brazing shield is provided in the information pack accompanying this unit. This shield fits over the refrigerant fittings while brazing. Wet the shield before brazing. See Figure 16.

IMPORTANT:

Do NOT unseal refrigerant tubing until ready to cut and fit refrigerant lines.

1. Remove both sealing caps from indoor coil.
2. Field supplied tubing should be cut squared-off, ensuring the tube is still round and free of burrs at the connecting end. Clean the tubing to prevent contaminants from entering the system.
3. Run refrigerant tubing into the stub sockets of indoor unit coil. **Refrigerant line openings must be completely sealed.**
4. Braze and evacuate according to indoor and outdoor installation instructions.
5. Seal around refrigerant lines.

PAINTED AREAS OF UNIT MUST BE SHIELDED DURING BRAZING

G. CONDENSATE DRAIN PIPING

NOTE: Make certain that the unit has been installed in a level position to ensure proper draining.

The indoor blower is downstream of the evaporator coil which creates a negative pressure at the condensate drain connections during operation. The condensate drain connections in front of the indoor coil are 3/4" NPT. The lower connection is the primary drain. See Figure 17.

Two secondary drain connections are provided for the different orientations (See Figure 17). The lower of the two should be connected as a backup to prevent condensate overflow by a blocked primary drain.

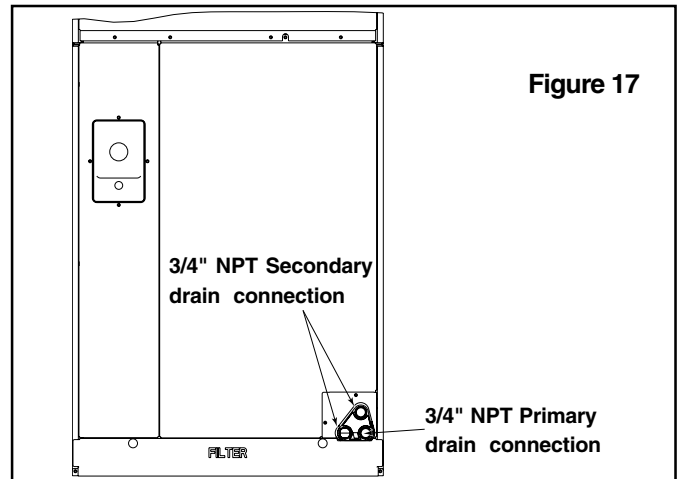

Figure 17

For proper drainage of condensate, the following steps should be followed:

1. The primary drain line must be trapped with a minimum of 2" water seal as shown in Figures 17 & 18. **Do not use preformed 3/4" PVC running traps.**

The use of Field fabricated or manufactured traps as shown in Figures 18 & 19 is acceptable. The manufactured trap shown in Figure 18 allows for a float switch option to be added.

Refer to the manufacturers data and instructions for details.

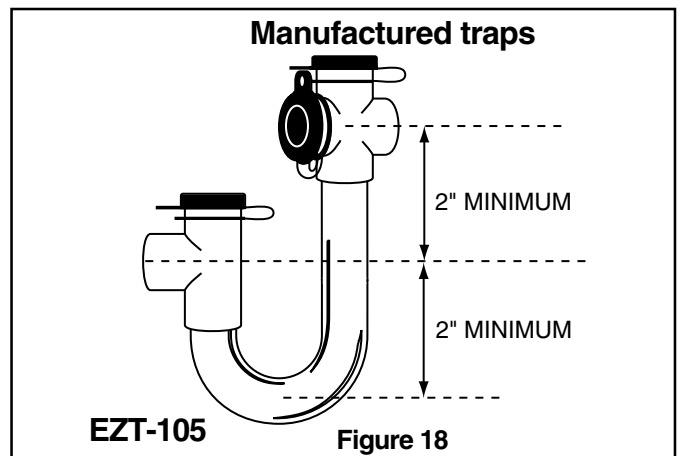

EZT-105

Figure 18

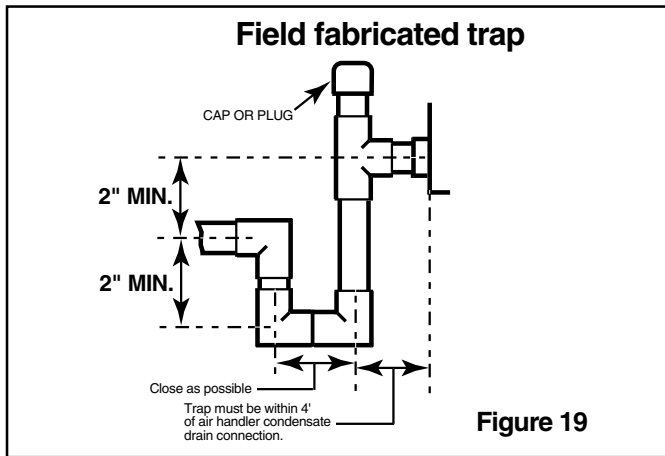

2. The trap must be located within 4 feet of the air handler drain outlet connection.
3. It is recommended that a clean-out tee or cross be installed in the primary drain line for future maintenance (See Figure 18 & 19).
4. Do not use reducing fittings in the condensate drain lines.
5. Slope the drain lines downward a minimum of 1/4" per foot.
6. Insulate the primary drain to prevent sweating where pipe temperature could meet or fall below dewpoint temperatures.
7. **Provide means for drainage to prevent winter freeze-up of condensate line.**
8. Do not connect the drain line to a closed drain system.
9. Use Teflon® tape on the air handler drain line connections! **Do Not** Use pipe joint compound or PVC/CPVC cement!

It is always recommended that an auxiliary drain pan be installed under a horizontally installed air handler.

Connect the auxiliary drain line to a separate drain line (no trap is needed in this line) and terminate according to local codes.

NOTE: DO NOT use a torch or flame near the plastic drain pan coupling.

NOTE: DO NOT tighten the drain pipe excessively. Support the condensate piping and traps outside the unit to prevent strain on the drain coupling.

H. ELECTRICAL — POWER WIRING

1. These Air Handlers are shipped from the factory wired for 230 volts. The units may be wired for 208 volts. Follow instructions on unit wiring diagram located on blower housing and in the Service Facts document included with the unit.
2. The selection of wire and fuse sizes should be made according to the Minimum Branch Circuit Ampacity and the Maximum Overcurrent Device listed on the unit nameplate.

⚠ WARNING

TO PREVENT INJURY OR DEATH DUE TO ELECTRICAL SHOCK OR CONTACT WITH MOVING PARTS, LOCK UNIT DISCONNECT SWITCH IN OPEN POSITION BEFORE SERVICING UNIT.

3. Field wiring diagrams for electric heaters and unit accessories are shipped with the accessory.
4. Wiring must conform to National and Local codes.

If an electric heater is not installed, connections are made through the 7/8" knockout into the air handler junction box to the two power leads and ground wire connections which are located near the discharge of the blower.

NOTE: If air handler is used with or without a heater, the electrical entry hole as well as any other cabinet penetrations must be sealed air-tight.

I. CONTROL WIRING

1. Connect wiring between indoor unit, outdoor unit and Comfort Control. The use of color-coded low-voltage wires is recommended.
2. A low voltage terminal board is provided for control wiring, and is located on the left side of the cross brace in the center of the unit.
3. If the low voltage wiring diagram is not listed in this installer's guide for the particular application, refer to the wiring diagram located on the control box cover of the outdoor unit or in the outdoor unit's service facts.

IMPORTANT:

When supplementary heaters are installed, inspect to insure that all packaging material has been removed.

J. AIRFLOW ADJUSTMENT

⚠ CAUTION

Disconnect power to the air handler before changing dip switch positions. Failure to follow this procedure may result in equipment damage.

Blower speed changes are made on the ECM Fan Control mounted on the control box. The ECM Fan Control controls the variable speed motor.

There is a bank of 8 dip switches (See Figure 20). The dip switches work in pairs to match the airflow for the outdoor unit size (tons), cooling airflow adjustment, Fan off-delay options, and heating airflow adjustment. The switches appear as shown in Figure 21.

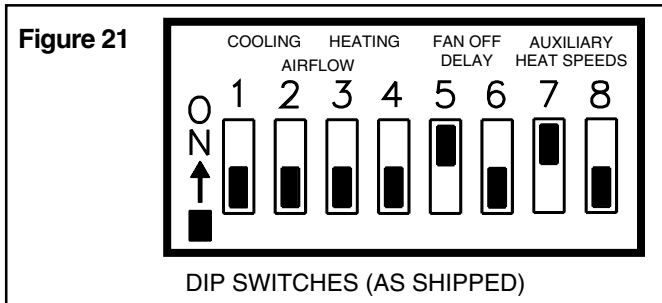
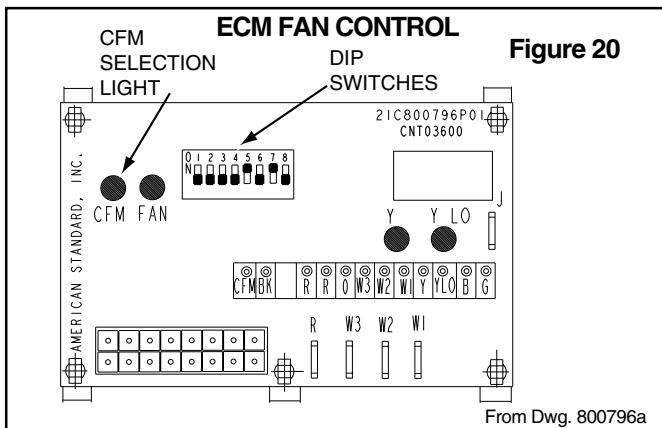

If the airflow needs to be increased or decreased, see the Airflow Label on the air handler or the Blower Performance Table in the Service Facts. Information on changing the speed of the blower motor for your specific outdoor model size is in the Blower Performance Table.

Be sure to set the airflow for the correct tonnage. Refer to blower housing for correct setting.

- Switches 1 - 4 Cooling Airflow
- Switches 5 - 6 Fan Off Delay Options
- Switches 7 - 8 Auxiliary Heat

If the optional humidistat is used, remove R-BK jumper from the low voltage terminal board (not shown) and install the humidistat between R and BK. (Jumper R to O for cooling-only/non-heat pump systems with a humidistat.)

INDOOR BLOWER TIMING

IMPORTANT:

Leave dip switch 5 & 6 in the "as-shipped" position during system start-up and check out. Afterwards, adjust as desired.

The FAN-OFF period is set on the ECM Fan Control board by dip switches #5 and #6. The blower off-delay settings are as follows:

COOLING OFF - DELAY OPTIONS

| SWITCH SETTINGS | | SELECTION | NOMINAL AIRFLOW |
|-----------------|---------|-------------|-----------------|
| 5 - OFF | 6 - OFF | NONE | SAME |
| 5 - ON | 6 - OFF | 1.5 MINUTES | 100% * |
| 5 - OFF | 6 - ON | 3 MINUTES | 50% |
| 5 - ON | 6 - ON | ENHANCED** | 50 - 100% |

** - This ENHANCED MODE selection provides a ramping up and ramping down of the blower speed to provide improved comfort, quietness, and potential energy savings. The graph shows the ramping process.

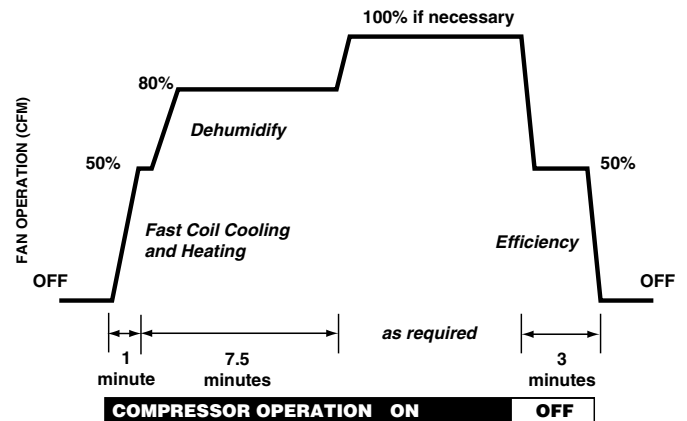

NOTE: Direct drive motors have bearings which are permanently lubricated and under normal use lubrication is not recommended.

K. CHECKOUT PROCEDURE

1. Check the Air Handler installation in accordance with the instructions on page 16.
2. "Operational Procedure" for the system installation can be found in the outdoor unit installer guide and will be compatible with this Air Handler.

Installer's Guide

2/4TEE3F39, 48, 64A AIR HANDLERS WITH SINGLE STAGE COOLING, 2 STAGE HEAT

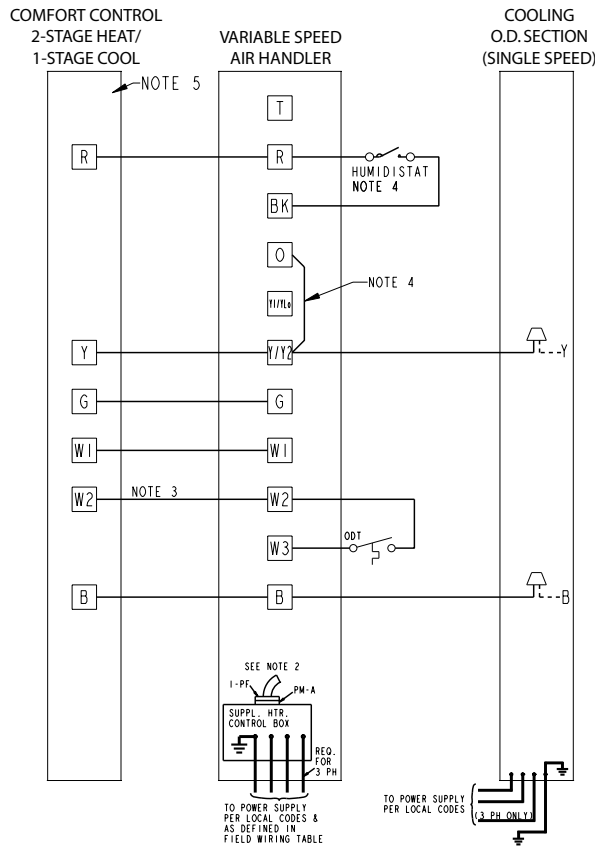

NOTES:

1. LOW VOLTAGE WIRING TO BE NO. 18 A.W.G. MINIMUM CONDUCTOR.
2. WHEN HEATERS ARE USED, DISCARD POWER LEADS WITH POLARIZED PLUG PM-A AND CONNECT 1-PF TO MATING PLUG IN THE HEATER CONTROL BOX AS SHOWN.
3. TERMINAL W2 WILL HAVE INTERNAL CONNECTIONS ONLY IF 2ND CONTACTOR IS USED BY THE HEATER FOR CONTROLLING POWER TO ELECTRIC HEAT ELEMENTS. IF 2ND (BH) ZCONTACTOR IS NOT USED, THEN FIELD CONNECTIONS TO W2 CAN BE OMITTED AS APPROPRIATE.
4. CONNECTIONS TO "R", "BK", "O" AND "Y" MUST BE MADE AS SHOWN FOR PROPER OPERATION OF BLOWER WITH HUMIDISTAT IN COOLING.
5. SEE HEATER WIRING DIAGRAM FOR HEATING ANTICIPATOR SETTING.

INTER-COMPONENT WIRING

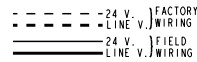

From Dwg. No. B801074

2/4TEE3F39, 48, 64A AIR HANDLERS WITH TWO STAGE COOLING, 2 STAGE HEAT

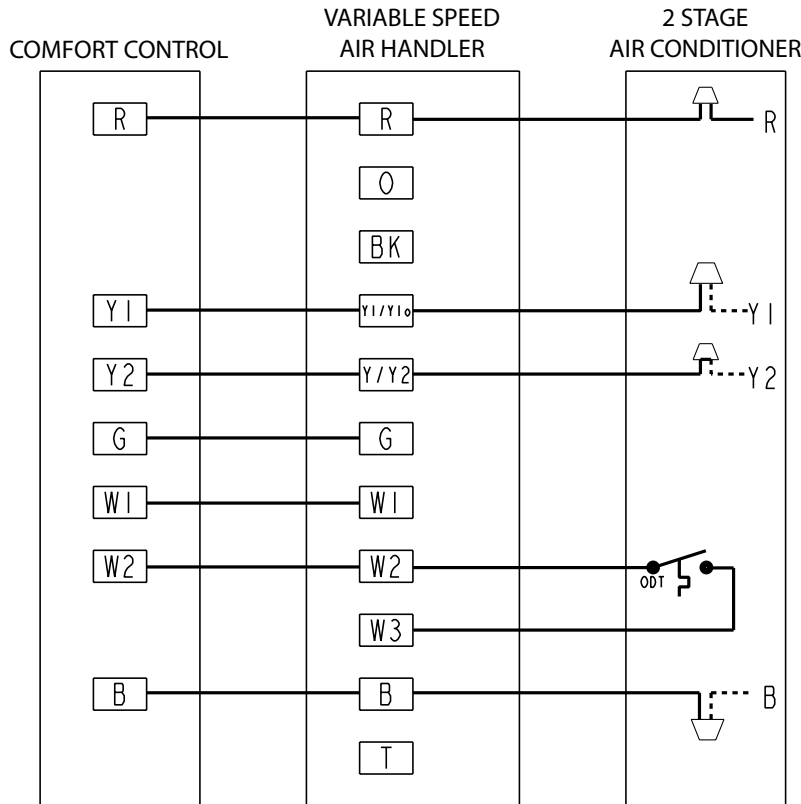

NOTES:

1. BE SURE POWER SUPPLY AGREES WITH EQUIPMENT NAMEPLATE.
2. POWER WIRING AND GROUNDING OF EQUIPMENT MUST COMPLY WITH LOCAL CODES.
3. LOW VOLTAGE WIRING TO BE NO. 18 AWG MINIMUM CONDUCTOR.
4. IF OUTDOOR THERMOSTAT (ODT) IS NOT USED, CONNECT W2 TO W3.

24V INTER-COMPONENT WIRING

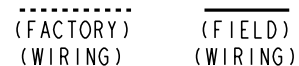

PRINTED FROM B152935P03

2/4TEE3F39, 48, 64A AIR HANDLERS WITH SINGLE STAGE HEAT PUMP

COMFORT CONTROL VARIABLE SPEED AIR HANDLER HEAT PUMP O.D. SECTION (SINGLE SPEED)

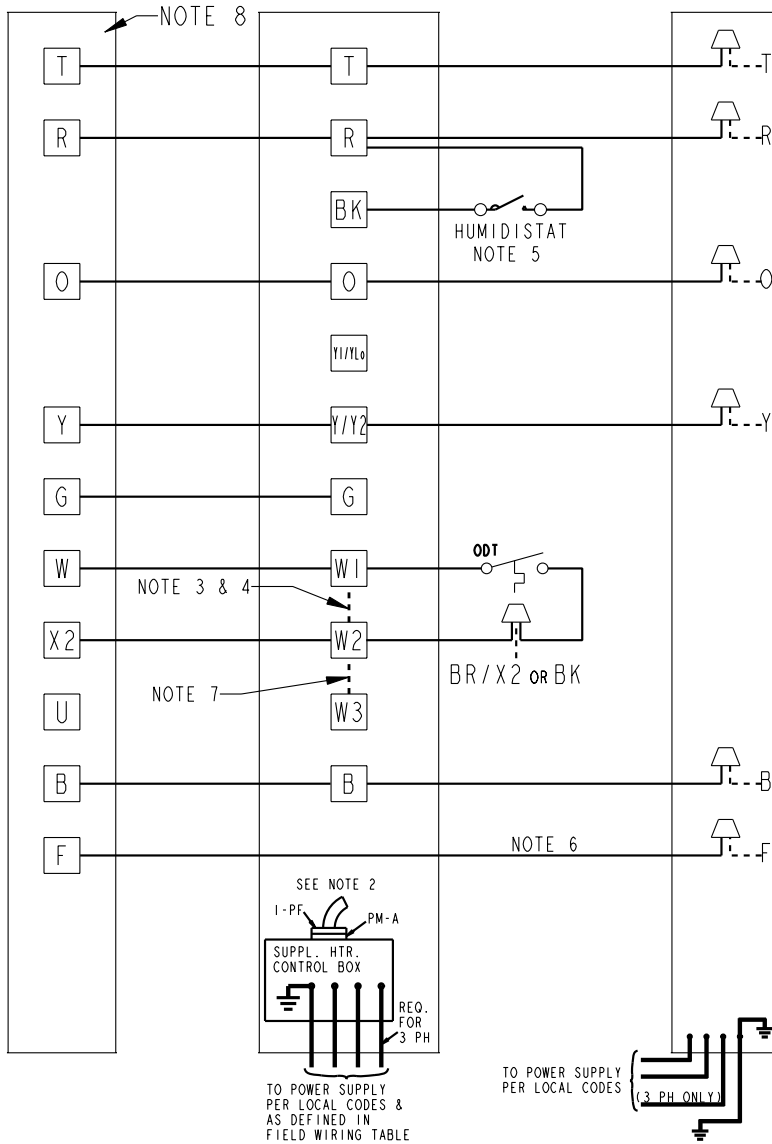

NOTES:

1. LOW VOLTAGE WIRING TO BE NO. 18 A.W.G. MINIMUM CONDUCTOR.
2. WHEN HEATERS ARE USED, DISCARD POWER LEADS WITH POLARIZED PLUG PM-A AND CONNECT 1-PF TO MATING PLUG IN THE HEATER CONTROL BOX AS SHOWN.
3. TERMINAL W2 WILL HAVE INTERNAL CONNECTIONS ONLY IF 2ND CONTACTOR IS USED BY THE HEATER FOR CONTROLLING POWER TO ELECTRIC HEAT ELEMENTS. IF 2ND (BH) ZCONTACTOR IS NOT USED, THEN FIELD CONNECTIONS TO W2 CAN BE OMITTED AS APPROPRIATE.
4. IF ODT IS NOT USED, THEN CONNECT APPROPRIATE JUMPER FROM W1 TO W2 TO W3 ON LVTB.
5. IF HUMIDISTAT IS NOT USED, CONNECT JUMPER FROM "R" TO "BK" FOR FULL TONNAGE AIRFLOW IN COOLING.
6. CONNECT IN THIS MANNER IF O.D. UNIT HAS "F" CONNECTION.
7. CONNECT W2 TO W3 ONLY IF USING HEATER WITH 3 HEATER STAGES.
8. SEE HEATER WIRING DIAGRAM FOR HEATING ANTICIPATOR SETTING.

INTER-COMPONENT WIRING

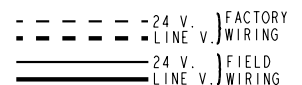

From Dwg. No. B801077

OUTLINE DRAWING FOR 2/4TEE3F39, 48, 64A1000A

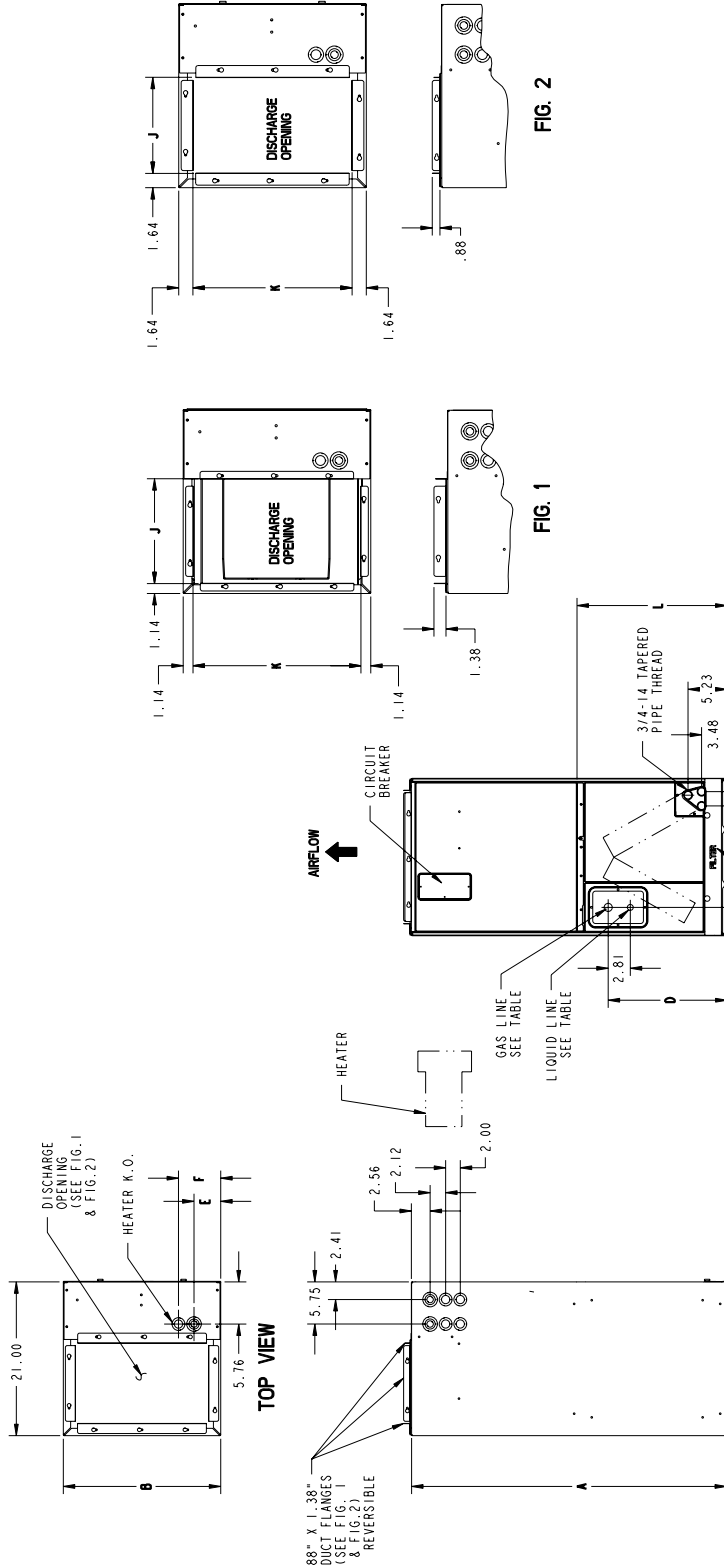

VERTICAL UPFLOW

| MINIMUM UNIT CLEARANCE TABLE | | TO SERVICE CLEARANCE (RECOMMENDED) |
|------------------------------|----|------------------------------------|
| SIDES | 0" | 2" |
| FRONT | 0" | 21" |
| BACK | 0" | 0" |
| INLET DUCT | 0" | 0" |
| OUTLET DUCT | 1" | 1" |

* 1" FOR THE FIRST 3 FT. OF OUTLET DUCT WHEN ELECTRIC HEATERS ARE INSTALLED EXCEPT MODELS BAYHTR1405, 1408 AND 1410 ARE APPROVED FOR 0" PLENUM AND DUCT CLEARANCE IN THE UPFLOW CONFIGURATION ONLY ON THE-P MODELS.

| MODEL NO. | A | B | C | D | E | F | G | H | L | FLOW CONTROL | GAS LINE BRAZE | LIQ LINE BRAZE |
|-----------|------|------|------|-------|------|------|------|------|-------|--------------|----------------|----------------|
| 2TEE3F39 | | | | | | | | | | | 7/8 | |
| 2TEE3F48 | | | | | | | | | | | 1-1/8 | |
| 2TEE3F64 | 57.9 | 23.5 | 21.5 | 17.57 | 4.65 | 6.77 | 3.62 | 1.89 | 31.15 | TXV / NB | 3/4 | 3/8 |
| 4TEE3F39 | | | | | | | | | | | 7/8 | |
| 4TEE3F48 | | | | | | | | | | | 7/8 | |
| 4TEE3F64 | | | | | | | | | | | 7/8 | |

From Dwg. D802101 Rev. 1

2/4TEE3F39, 48, 64A AIR HANDLERS DIMENSIONAL DATA

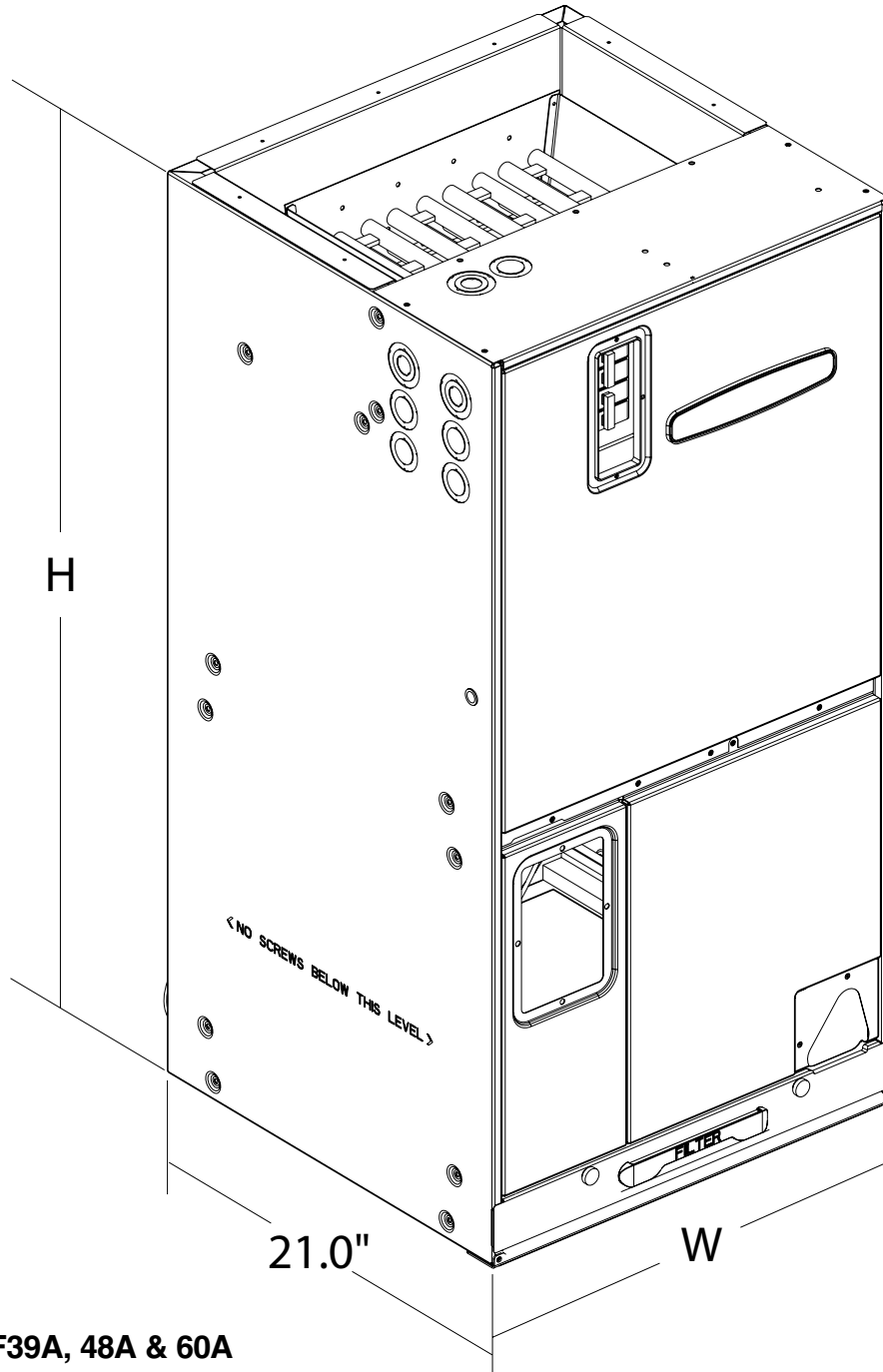

**2/4TEE3F39A, 48A & 60A
Are two piece cabinets**

| Model No. | H | W |
|------------------|-------|-------|
| 2/4TEE3F39A1000A | 57.90 | 23.50 |
| 2/4TEE3F48A1000A | | |
| 2/4TEE3F64A1000A | | |

CHECKOUT PROCEDURES

After installation has been completed, it is recommended that the Air Handler be checked against the following checklist.

1. Make sure power is "OFF" at power disconnect switch []
2. Check all field wiring for tight connections. See that grounding of unit is in accord with code []
3. Make sure unit suspension (if used) is secure and that there are no tools or loose debris in, around or on top of the unit []
4. Check all duct outlets; they must be open and unrestricted []
5. Check drain lines and be sure all joints are tight []
6. Make sure secondary drain pan is installed []
7. Check power supply for correct requirements per unit nameplate []
8. Check filters for proper size. Inform owner of proper procedure for removal and reinstallation []
9. Energize the system and carefully observe its operation; make any necessary adjustment []
10. Instruct owner, engineer (if possible) on proper operating procedure and leave Use and Care Manual with owner []

SUPPLEMENTARY HEATERS CHECKOUT PROCEDURES, IF a heater is USED, see "limitations and recommendations" to determine if the heater requires a SPECIAL CIRCUIT.

1. Be sure the disconnect switch is "OFF", and safety label (if any) is attached []
2. Check on field wiring for tight connections and grounding according to codes []
3. Check circuit protection for proper size per nameplate specifications []
4. Check control box panel — in place and secured []

NOTE: OPERATION OF HEATERS MUST BE CHECKED DURING THE OPERATION CHECK OF THE TOTAL SYSTEM.