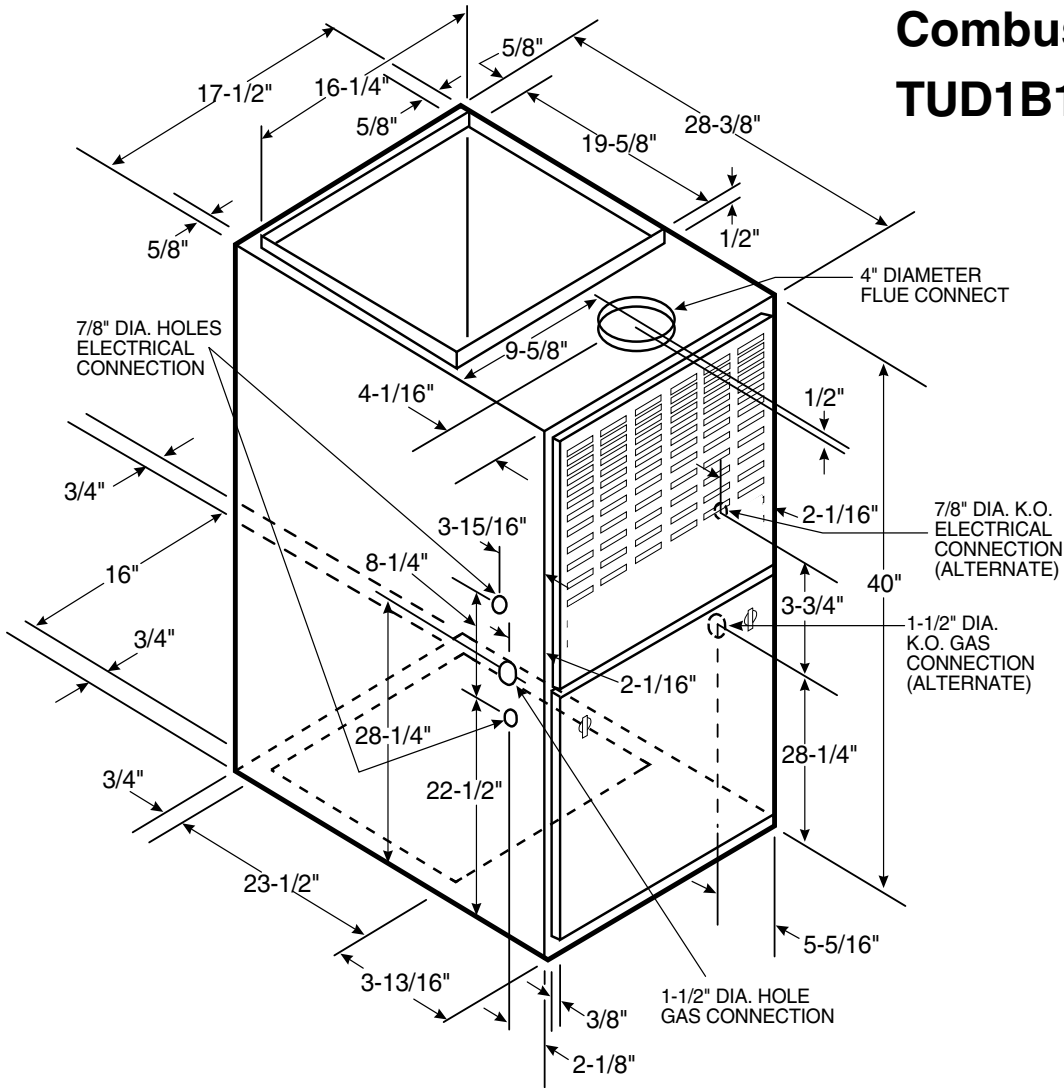

TAG: _____

SUBMITTAL

Upflow / Horizontal Gas Furnace "Fan-Assisted Combustion"

TUD1B100A9451A

FURNACE AIRFLOW (CFM) VS. EXTERNAL STATIC PRESSURE (IN. W.C.)

MODEL	SPEED TAP	0.10	0.20	0.30	0.40	0.50	0.60	0.70	0.80	0.90
TUD1B100A9451A	4 - HIGH - Black	1771	1731	1682	1624	1556	1479	1392	1296	1191
	3 - MED.-HIGH - Blue	1375	1371	1355	1328	1289	1238	1176	1102	1016
	2 - MED.-LOW - Yellow	1127	1141	1140	1124	1094	1049	989	914	825
	1 - LOW - Red	780	815	829	822	796	749	681	593	485

**CFM VS. TEMPERATURE RISE
CFM (CUBIC FEET PER MINUTE)**

MODEL	1200	1300	1400	1500	1600	1700	1800
TUD1B100A9451A	62	57	53	49	46	44	41

General Data ①

TYPE	Upflow / Horizontal	VENT COLLAR — Size (in.)	4 Round
RATINGS ②		HEAT EXCHANGER	
Input BTUH	100,000	Type-Fired	Alum. Steel
Capacity BTUH (ICS) ③	80,000	-Unfired	
AFUE	80.0	Gauge (Fired)	20
Temp. rise (Min.-Max.) °F.	35 - 65	ORIFICES — Main	
BLOWER DRIVE	DIRECT	Nat. Gas Qty. — Drill Size	5 — 45
Diameter-Width (In.)	10 x 8	L.P. Gas Qty. — Drill Size	5 — 56
No. Used	1	GAS VALVE	Redundant - Single Stage
Speeds (No.)	4	PILOT SAFETY DEVICE	
CFM vs. in. w.g.	See Fan Performance	Type	Hot Surface Ignition
Motor HP	1/3	BURNERS — Type	Multiport Inshot
R.P.M.	1075	Number	5
Volts/Ph/Hz	115/1/60	POWER CONN. — V/Ph/Hz ④	115/1/60
COMBUSTION FAN - Type	Centrifugal	Ampacity (In Amps)	9.8
Drive - No. Speeds	Direct - 1	Max. Overcurrent Protection (amps)	15
Motor HP - RPM	1/50 - 3180	PIPE CONN. SIZE (IN.)	1/2
Volts/Ph/Hz	115/1/60	DIMENSIONS	H x W x D
F.L. Amps	1.09	Crated (In.)	41- 3/4 x 19-1/2 x 30-1/2
FILTER — Furnished?	No	Uncrated (In.)	40 x 17-1/2 x 28
Type Recommended	High Velocity	WEIGHT	
Hi Vel. (No.-Size-Thk.)	1 - 17x25 - 1in.	Shipping (Lbs.) / Net (Lbs)	153 / 143

① Central Furnace heating designs are certified by the American Gas Association Inc. Laboratories.

② Ratings shown are for elevations up to 2000 feet. For elevations above 2000 feet; Ratings should be reduced at the rate of 4% for each 1000 feet above sea level.

③ Based on U.S. Government Standard Tests.

④ The above wiring specifications are in accordance with National Electrical Code; however, installations must comply with local codes.

Mechanical Specifications

NATURAL GAS MODELS—Central heating furnace designs are certified by the American Gas Association for both natural and L.P. gas. Limit setting and rating data were established and approved under standard rating conditions using American National Standards Institute standards.

SAFE OPERATION — The Integrated System Control has solid state devices, which continuously monitor for presence of flame, when the system is in the heating mode of operation. Dual solenoid combination gas valve and regulator provide extra safety.

QUICK HEATING—Durable, cycle tested, heavy gauge **aluminized steel heat exchanger** quickly transfers heat to provide warm conditioned air to the structure. **Low energy power vent blower**, to increase efficiency and provide discharge of gas fumes to the outside, allows common venting with hot water heater.

BURNERS — Multi-port, in-shot burners will give years of quiet and efficient service. All models can be converted to **L.P. gas** without changing burners.

INTEGRATED SYSTEM CONTROL— Exclusively designed operational program provides total control of furnace limit sensors, blowers, gas valve, flame control and includes self diagnostics for ease of service.

AIR DELIVERY — The multispeed, direct-drive blower motor, with sufficient airflow range for most heating and cooling requirements, will switch from heating to cooling speeds on demand from room thermostat. The blower door safety switch will prevent or terminate furnace operation when the blower door is removed. (Fan relay and 35VA control transformer is standard).

STYLING — **Heavy gauge steel and "wraparound" cabinet construction** is used in the cabinet with baked-on enamel finish for strength and beauty. The heat exchanger section of the cabinet is completely lined with foil-faced fiberglass insulation. This results in quiet and efficient operation due to the excellent acoustical and insulating qualities of fiberglass.

FEATURES AND GENERAL OPERATION — These High Efficiency Gas Furnaces employ a Hot Surface Ignition system, which eliminates the waste of a constantly burning pilot. The integrated system control lights the main burners upon a demand for heat from the room thermostat. Complete front service access.

- Low energy power venter.
- Vent proving differential switch.



Since Trane has a policy of continuous product and product data improvement, it reserves the right to change specifications and design without notice.

Technical Literature - Printed in U.S.A.

Trane
6200 Troup Highway
Tyler, TX 75707
www.trane.com

Library	-
Product Section	-
Product	Furnace
Model	TUD1
Literature Type	Submittal
Sequence	-
Date	2/08
File No.	TUD1B100-SUB-2
Supersedes	TUD1B100A9451A