



**TRANE®**

# Cooling/Heat Pump Convertible Air Handlers

---

**4TEC3F24B1000A  
4TEC3F36B1000A  
4TEC3F42C1000A  
4TEC3F48B1000A  
4TEC3F60B1000A**

**2 – 5 Ton**

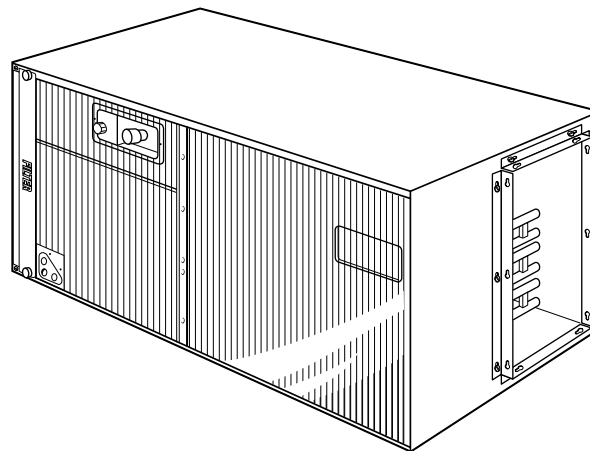
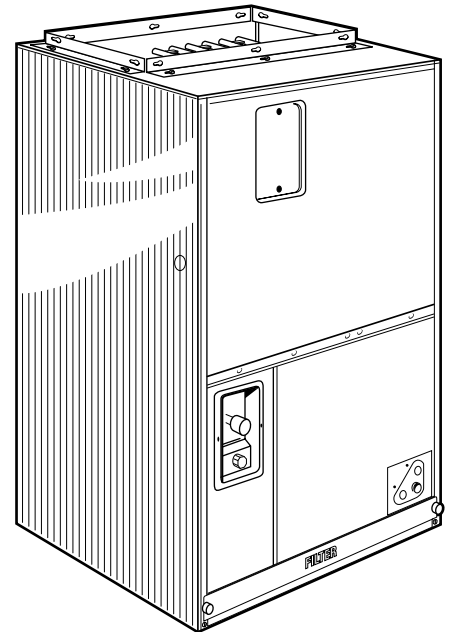

---

**PUB. NO. 22-1774-18**



# Features and Benefits

- 13.0 SEER
- Ships vertical — converts to horizontal by laying unit on its side.
- Six-way convertibility – horizontal (left & right), front and rear access; upflow, downflow
- “1-man” installation opportunity
- Electrical, refrigerant, condensate & blower access convertible to either side
- Compact 21" depth for easy installation
- Corrosion resistant galvanized metal with attractive finish
- Superior condensate performance
- Factory installed non-bleed TXV
- Easy Air-Tite™ access to coil
- Meets or exceeds Florida 2% leakage criteria
- Enhanced internally finned coil tubes
- Multi-speed, Direct drive motor
- Versatile duct flange - allows flush fit 3/4", 1" or 1.5" duct insulation
- Filter panel stamped with word “filter”
- 200/230 volt primary & 24 volt secondary transformer
- Low voltage wire nut connections
- Insulated cabinet
- Uses 1400 series heaters
- External access to heater circuit breakers
- Polarized plugs for making electrical connections from air handler control box to heaters
- Approved for modular or manufactured homes

## Selection Procedure

### Model Number Nomenclature

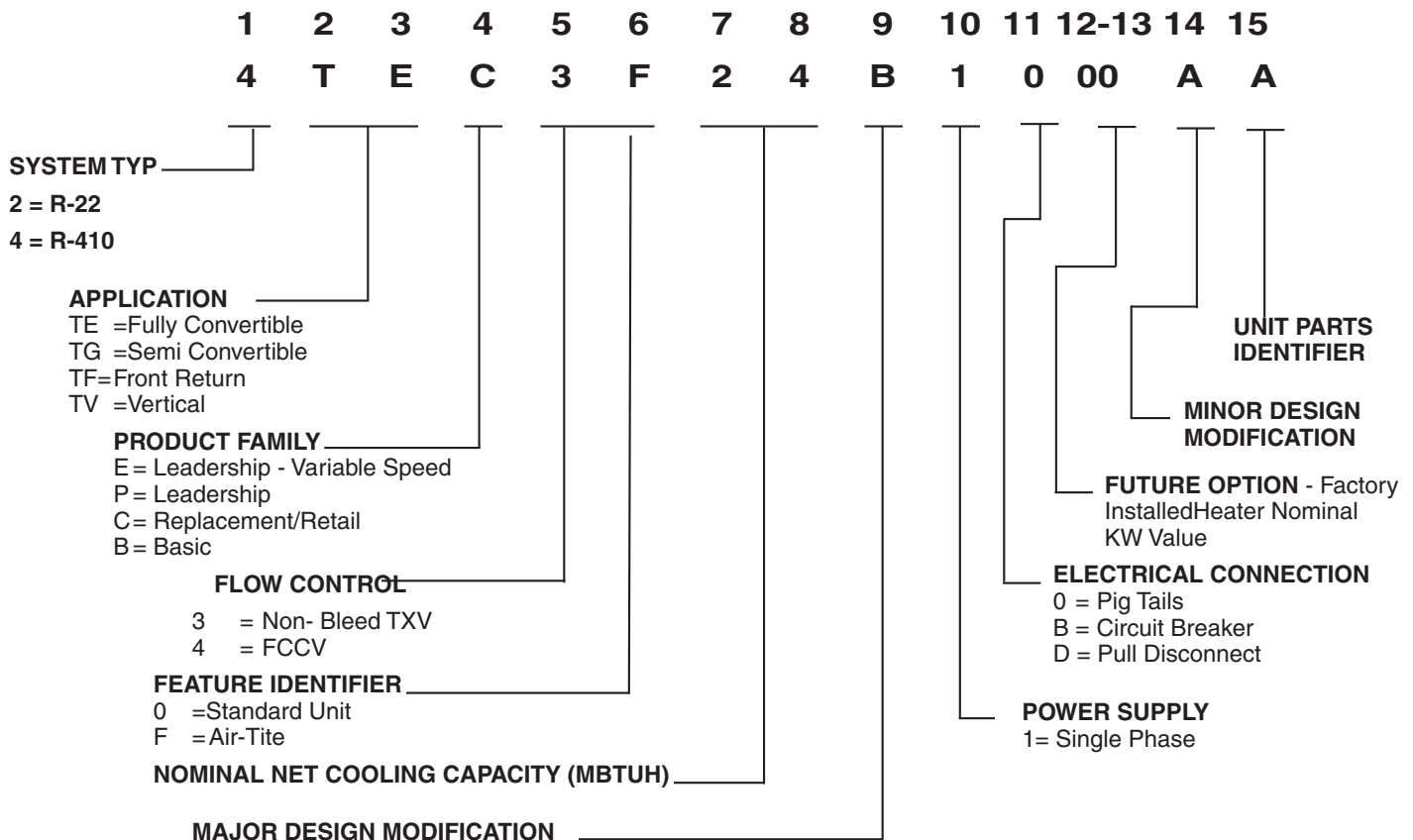

# Contents

---

<b>Features and Benefits</b>	<b>2</b>
<b>Selection Procedure</b>	<b>2</b>
Model Number Nomenclature	2
<b>General Data</b>	<b>4</b>
4TEC3F24B1000A	4
4TEC3F36B1000A	4
4TEC3F42C1000A	4
4TEC3F48B1000A	4
4TEC3F60B1000A	4
<b>Performance Data</b>	<b>6</b>
<b>Electrical Data</b>	<b>12</b>
<b>Field Wiring</b>	<b>18</b>
<b>4TEC3F24-60B Convertibility</b>	<b>20</b>
<b>Dimensions</b>	<b>21</b>
<b>Mechanical Specification Options</b>	<b>22</b>



# General Data

MODEL	4TEC3F24B1000A	4TEC3F36B1000A	4TEC3F42C1000A
<b>RATED VOLTS/PH/HZ.</b>	208-230/1/60	200-230/1/60	200-230/1/60
<b>RATINGS</b> ①	See O.D. Specifications	See O.D. Specifications	See O.D. Specifications
<b>INDOOR COIL — Type</b>	Plate Fin	Plate Fin	Plate Fin
Rows — F.P.I.	3 - 14	3 — 14.0	3 — 14
Face Area (sq. ft.)	3.21	3.67	5.04
Tube Size (in.)	3/8 - Copper	3/8 - Copper	3/8 - Copper
Refrigerant Control	TXV-NB	TXV-NB	TXV-NB
Drain Conn. Size (in.) ②	3/4 NPT	3/4 NPT	3/4 NPT
<b>INDOOR FAN — Type</b>	Centrifugal	Centrifugal	Centrifugal
Diameter-Width (in.)	9 X 8	10 x 7	10 x 10
No. Used	1	1	1
Drive - No. Speeds	Direct - 3	Direct - 3	Direct - 4
CFM vs. in w.g.	See Fan Performance Table	See Fan Performance Table	See Fan Performance Table
No. Motors — H.P.	1 - 1/3	1 — 1/3	1 — 1/2
Motor Speed R.P.M.	1075	1080	1075
Volts/Ph/Hz	200-230/1/60	200-230/1/60	200-230/1/60
F.L. Amps - L.R. Amps	1.55 - 2.6	2.2 - 5.3	3.3 - 6.9
<b>FILTER</b>			
<b>Vertical Applications</b>			
Filter Furnished?	Yes	Yes	Yes
Type Recommended	Throwaway	Throwaway	Throwaway
No.-Size-Thickness	1 - 20 X 20 x 1 in.	1 - 20 x 20 x 1 in.	1 - 20 x 20 x 1 in.
<b>Horizontal Applications</b>			
Filter Furnished?	No	No	No
Recommended Size ③	See Note ③	See Note ③	See Note ③
<b>REFRIGERANT</b>	<b>R-410A</b>	<b>R-410A</b>	<b>R-410A</b>
Ref. Line Connections	Brazed	Brazed	Brazed
Coupling or Conn. Size — in. Gas	5/8	3/4	3/4
Coupling or Conn. Size — in. Liq.	5/16	3/8	3/8
<b>DIMENSIONS</b>			
Crated (in.)	H x W x D 44 1/2 x 24 x 23-1/2	H x W x D 46-1/2 x 24 x 23-1/2	H x W x D 53-1/4 x 26 x 23-1/2
Uncrated	See Outline Drawing	See Outline Drawing	See Outline Drawing
<b>WEIGHT</b>			
Shipping (Lbs.) / Net (Lbs.)	121/111	135/125	165/150

MODEL	4TEC3F48B1000A	4TEC3F60B10001
<b>RATED VOLTS/PH/HZ.</b>	200-230/1/60	200-230/1/60
<b>RATINGS</b> ①	See O.D. Specifications	See O.D. Specifications
<b>INDOOR COIL — Type</b>	Plate Fin	Plate Fin
Rows — F.P.I.	3 - 14 (3-16, 4TEC)	3 — 14(3-16, 4TEC)
Face Area (sq. ft.)	6.19	6.19
Tube Size (in.)	3/8 - Copper	3/8 - Copper
Refrigerant Control	TXV-NB	TXV-NB
Drain Conn. Size (in.) ②	3/4 NPT	3/4 NPT
<b>INDOOR FAN — Type</b>	Centrifugal	Centrifugal
Diameter-Width (in.)	11 x 10	11 x 10
No. Used	1	1
Drive - No. Speeds	Direct - 3	Direct - 4
CFM vs. in w.g.	See Fan Performance Table	See Fan Performance Table
No. Motors — H.P.	1 — 1/2	1 — 1
Motor Speed R.P.M.	1000	1050
Volts/Ph/Hz	200-230/1/60	200-230/1/60
F.L. Amps - L.R. Amps	2.7 - 4.5	7.6
<b>FILTER</b>		
<b>Vertical Applications</b>		
Filter Furnished?	Yes	Yes
Type Recommended	Throwaway	Throwaway
No.-Size-Thickness	1 - 20 x 20 x 1 in.	1 - 20 x 22 x 1 in.
<b>Horizontal Applications</b>		
Filter Furnished?	No	No
Recommended Size ③	See Note ③	See Note ③
<b>REFRIGERANT</b>	<b>R-410A</b>	<b>R-410A</b>
Ref. Line Connections	Brazed	Brazed
Coupling or Conn. Size — in. Gas	7/8	7/8
Coupling or Conn. Size — in. Liq.	3/8	3/8
<b>DIMENSIONS</b>		
Crated (in.)	H x W x D 53-1/2 x 26 x 23-1/2	H x W x D 59-1/2 x 26 x 23-1/2
Uncrated	See Outline Drawing	See Outline Drawing
<b>WEIGHT</b>		
Shipping (Lbs.) / Net (Lbs.)	166/151	170/155

① These Air Handlers are A.R.I. certified with various Split System Air Conditioners and Heat Pumps (ARI STANDARD 210/240). Refer to the Split System Outdoor Unit Product Data Guides for performance data.

② 3/4" Male Plastic Pipe (Ref.: ASTM 1785-76)

③ Minimum filter size for horizontal applications will be based on airflow selection and will be calculated as follows:

Low Velocity Filter:  
Face area (Sq. Ft.) = CFM / 300  
High Velocity Filter:  
Face area (Sq. Ft.) = CFM / 500



Intertek





# General Data

## PRESSURE DROP FOR ELECTRIC HEATERS IN AIR HANDLER MODELS

HEATER RACKS	
HEATER MODEL NO.	NO. OF RACKS
BAYHTR1405	1
BAYHTR1408	2
BAYHTR1410	2
BAYHTR3410	2
BAYHTR1415	3
BAYHTR3415	3
BAYHTR1419	4
BAYHTR1425	5

AIRFLOW CFM	NUMBER OF RACKS				
	1	2	3	4	5
	AIR PRESSURE DROP INCHES W.G.				
600	0.01	0.02	0.02		
700	0.01	0.02	0.02		
800	0.02	0.03	0.03	0.04	
900	0.03	0.03	0.04	0.05	
1000	0.04	0.04	0.05	0.06	
1100	0.04	0.05	0.06	0.07	0.08
1200	0.05	0.06	0.07	0.08	0.09
1300	0.06	0.07	0.08	0.09	0.11
1400	0.07	0.08	0.10	0.11	0.13
1500	0.08	0.09	0.11	0.13	0.15
1600	0.09	0.10	0.12	0.15	0.17
1700	0.10	0.11	0.14	0.17	0.19
1800	0.11	0.13	0.16	0.19	0.21
1900	0.13	0.15	0.18	0.21	0.23
2000	0.14	0.17	0.20	0.23	0.26

**NOTES:**

1. See Product Data or Air Handler nameplate for approved combinations of Air Handlers and Heaters
2. Heater model numbers may have additional suffix digits.



# Performance Data

Airflow Performance 4TEC3F24B: Wet coil, No Heaters												
EXTERNAL STATIC PRESSURE (in.w.g.)	AIRFLOW (CFM)											
	VERTICAL						HORIZONTAL					
	230 VOLTS			208 VOLTS			230 VOLTS			208 VOLTS		
	HI	MED	LO	HI	MED	LO	HI	MED	LO	HI	MED	LO
0	1134	876	818	1093	781	723	1083	870	813	1050	780	739
0.1	1102	839	789	1073	751	696	1051	831	783	1020	745	697
0.2	1048	798	751	1020	713	661	996	783	739	967	703	657
0.3	984	750	705	953	668	618	930	728	687	903	655	614
0.4	912	694	649	880	614	567	858	667	628	833	600	563
0.5	833	622	581	802	548	504	782	597	561	758	533	499
0.6	738	532	496	714	465	425	693	512	479	669	452	417
0.7	614	416	385	599	358	321	579	406	375	554	349	313
0.8	442	268	240	434	216	184	418	266	236	391	217	182
0.9	197	-	-	187	-	-	184	-	-	156	-	-
NOTES:	With filter, no horizontal drip tray Small apex baffle Subtract 0.06" W.G. for downflow						As shipped except without filter Subtract 0.05" W.G. for horizontal left					



# Performance Data

Airflow Performance 4TEC3F36B: Wet coil, No Heaters												
EXTERNAL STATIC PRESSURE (in.w.g.)	AIRFLOW (CFM)											
	VERTICAL						HORIZONTAL					
	230 VOLTS			208 VOLTS			230 VOLTS			208 VOLTS		
	HI	MED	LO	HI	MED	LO	HI	MED	LO	HI	MED	LO
0	1484	1282	1077	1402	1200	963	1402	1265	1069	1349	1165	947
0.1	1412	1268	1082	1352	1166	948	1350	1228	1048	1298	1131	915
0.2	1344	1226	1055	1292	1130	924	1289	1180	1015	1243	1090	890
0.3	1277	1171	1013	1227	1089	893	1225	1127	976	1185	1047	866
0.4	1209	1110	965	1163	1040	856	1163	1073	933	1127	1001	836
0.5	1139	1049	915	1098	982	814	1104	1019	887	1066	953	795
0.6	1065	987	862	1031	915	764	1043	962	835	1001	898	743
0.7	988	916	799	957	839	703	977	897	771	929	829	677
0.8	907	827	713	870	757	624	894	815	689	846	736	599
0.9	823	702	584	760	671	521	783	707	579	745	609	513
NOTES:	With filter, no horizontal drip tray Small apex baffle Subtract 0.06" W.G. for downflow						As shipped except without filter Subtract 0.05" W.G. for horizontal left					



# Performance Data

Airflow Performance 4TEC3F42C: Wet coil, No Heaters												
EXTERNAL STATIC PRESSURE (in.w.g.)	AIRFLOW (CFM)											
	VERTICAL						HORIZONTAL					
	230 VOLTS			208 VOLTS			230 VOLTS			208 VOLTS		
	HI	MED	LO	HI	MED	LO	HI	MED	LO	HI	MED	LO
0	1869	1690	1435	1723	1435	1100	1793	1533	1309	1721	1400	1100
0.1	1715	1542	1316	1640	1367	1079	1721	1522	1277	1665	1389	1095
0.2	1609	1449	1237	1561	1317	1060	1651	1471	1237	1600	1350	1068
0.3	1529	1380	1177	1485	1274	1032	1578	1400	1190	1527	1294	1030
0.4	1458	1314	1123	1409	1227	991	1500	1322	1139	1449	1231	987
0.5	1385	1240	1064	1332	1170	939	1417	1245	1085	1367	1164	940
0.6	1303	1158	1000	1251	1099	884	1329	1170	1026	1284	1094	889
0.7	1210	1078	932	1165	1015	838	1237	1092	963	1200	1019	826
0.8	1109	1018	870	1071	921	820	1145	1000	895	1117	931	740
0.9	1009	1010	829	968	825	854	1057	878	819	1034	820	617
NOTES:	With filter, no horizontal drip tray Small apex baffle Subtract 0.06" W.G. for downflow						As shipped except without filter Subtract 0.05" W.G. for horizontal left					





# Performance Data

Airflow Performance 4TEC3F48B: Wet coil, No Heaters												
EXTERNAL STATIC PRESSURE (in.w.g.)	AIRFLOW (CFM)											
	VERTICAL						HORIZONTAL					
	230 VOLTS			208 VOLTS			230 VOLTS			208 VOLTS		
	HI	MED	LO	HI	MED	LO	HI	MED	LO	HI	MED	LO
0	1945	1768	1617	1810	1618	1478	1959	1745	1582	1768	1562	1440
0.1	1880	1712	1583	1762	1574	1428	1910	1722	1612	1750	1606	1430
0.2	1824	1659	1532	1710	1526	1382	1860	1683	1582	1714	1577	1390
0.3	1770	1606	1474	1654	1476	1333	1810	1636	1524	1664	1511	1336
0.4	1712	1551	1415	1595	1421	1278	1758	1584	1457	1606	1436	1275
0.5	1647	1490	1358	1532	1360	1212	1700	1529	1394	1542	1365	1213
0.6	1571	1419	1296	1462	1290	1134	1636	1470	1336	1471	1300	1146
0.7	1485	1337	1219	1383	1206	1044	1561	1402	1274	1392	1228	1068
0.8	1391	1238	1113	1291	1101	945	1471	1319	1190	1300	1127	966
0.9	1293	1120	955	1180	970	840	1363	1212	1056	1190	959	821
NOTES:	With filter, no horizontal drip tray Small apex baffle Subtract 0.06" W.G. for downflow						As shipped except without filter Subtract 0.05" W.G. for horizontal left					



# Performance Data

Airflow Performance 4TEC3F60B: Wet coil, No Heaters																
EXTERNAL STATIC PRESSURE (in.w.g.)	AIRFLOW (CFM)															
	VERTICAL								HORIZONTAL							
	230 VOLTS				208 VOLTS				230 VOLTS				208 VOLTS			
	HI	MED-H	M-LO	Low	HI	MED-H	M-LO	Low	HI	MED-H	M-LO	Low	HI	MED-H	M-LO	Low
0	2163	2018	1901	1831	2129	1988	1893	1820	2107	1963	1840	1774	2085	1956	1837	1777
0.1	2132	1974	1852	1796	2091	1954	1833	1769	2063	1927	1810	1743	2049	1912	1797	1729
0.2	2088	1936	1811	1754	2049	1915	1790	1722	2028	1889	1773	1706	2011	1870	1756	1683
0.3	2044	1901	1775	1709	2008	1874	1756	1678	1995	1851	1735	1663	1973	1830	1716	1638
0.4	2004	1867	1741	1663	1970	1835	1723	1634	1962	1814	1698	1617	1934	1793	1678	1593
0.5	1972	1832	1707	1617	1935	1797	1687	1590	1925	1778	1662	1569	1896	1757	1641	1548
0.6	1941	1797	1672	1572	1899	1761	1646	1542	1883	1743	1628	1520	1855	1721	1606	1501
0.7	1902	1760	1635	1526	1858	1725	1602	1489	1834	1710	1595	1473	1812	1685	1570	1450
0.8	1841	1721	1594	1475	1803	1684	1556	1427	1779	1678	1559	1429	1761	1648	1531	1392
0.9	1735	1683	1549	1416	1722	1636	1516	1354	1719	1648	1518	1389	1699	1606	1484	1326
NOTES:	With filter, no horizontal drip tray Small apex baffle Subtract 0.06" W.G. for downflow								As shipped except without filter Subtract 0.05" W.G. for horizontal left							



# Performance Data

## Air Handler/Fan Speed Heater Matrix

Air Handler Model	Unit Position	Application	HEATER MODEL NUMBER BAYHTR					
			1405 4.80KW	1408 7.68KW	*410 9.60KW	*415 15.36KW	1419 19.20KW	1425 24.96KW
4TEC3F24B	Vertical	A/C or Elec. Furnace	L	L	L	L	—	—
	Upflow	Heat Pump	L	L	L	M	—	—
	Vertical	A/C or Elec. Furnace	L	L	L	L	—	—
	Downflow	Heat Pump	L	L	L	M	—	—
	Horizontal	A/C or Elec. Furnace	L	L	L	L	—	—
	Left	Heat Pump	L	L	L	M	—	—
	Horizontal	A/C or Elec. Furnace	L	L	L	L	—	—
	Right	Heat Pump	L	L	L	M	—	—
4TEC3F36B	Vertical	A/C or Elec. Furnace	L	L	L	L	L	—
	Upflow	Heat Pump	L	L	L	H	H	—
	Vertical	A/C or Elec. Furnace	L	L	L	L	L	—
	Downflow	Heat Pump	L	L	L	H	H	—
	Horizontal	A/C or Elec. Furnace	L	L	L	L	L	—
	Left	Heat Pump	L	L	L	H	H	—
	Horizontal	A/C or Elec. Furnace	L	L	L	L	L	—
	Right	Heat Pump	L	L	L	H	H	—
4TEC3F42C	Vertical	A/C or Elec. Furnace	ML	ML	ML	ML	ML	—
	Upflow	Heat Pump	ML	ML	ML	ML	H	—
	Vertical	A/C or Elec. Furnace	ML	ML	ML	ML	ML	ML
	Downflow	Heat Pump	ML	ML	ML	ML	H	—
	Horizontal	A/C or Elec. Furnace	ML	ML	ML	ML	ML	—
	Left	Heat Pump	ML	ML	ML	H	H	—
	Horizontal	A/C or Elec. Furnace	ML	ML	ML	ML	ML	—
	Right	Heat Pump	ML	ML	ML	H	H	—
4TEC3F48B	Vertical	A/C or Elec. Furnace	L	L	L	L	L	—
	Upflow	Heat Pump	L	L	L	L	M	—
	Vertical	A/C or Elec. Furnace	L	L	L	L	N/A	—
	Downflow	Heat Pump	L	L	L	H	N/A	—
	Horizontal	A/C or Elec. Furnace	L	L	L	L	L	—
	Left	Heat Pump	L	L	L	L	L	—
	Horizontal	A/C or Elec. Furnace	L	L	L	L	L	—
	Right	Heat Pump	L	L	L	L	L	—
4TEC3F60B	Vertical	A/C or Elec. Furnace	L	L	L	L	L	—
	Upflow	Heat Pump	L	L	L	L	ML	—
	Vertical	A/C or Elec. Furnace	L	L	L	L	L	—
	Downflow	Heat Pump	L	L	L	ML	MH	—
	Horizontal	A/C or Elec. Furnace	L	L	L	L	L	—
	Left	Heat Pump	L	L	L	ML	ML	—
	Horizontal	A/C or Elec. Furnace	L	L	L	L	L	—
	Right	Heat Pump	L	L	L	ML	L	—



# Electrical Data

4TEC3F24B WIRING DATA (Indoor Blower Motor Powered from Heater Circuit 1)											
Heater Model No.	Number of Circuits/Phase	240 VOLT					208 VOLT				
		Capacity		Heater Amps per Circuit	Minimum Circuit Ampacity	Maximum Overload Protection	Capacity		Heater Amps per Circuit	Minimum Circuit Ampacity	Maximum Overload Protection
		KW	BTUH				KW	BTUH			
NONE	1/1	N/A	N/A	N/A	2	15	N/A	N/A	N/A	2	15
BAYHTR1405+++	1/1	4.80	16400	20	27	30	3.60	12300	17.3	24	25
BAYHTR1408+++	1/1	7.68	26200	32	42	45	5.76	19700	27.7	37	40
BAYHTR1410 +++	1/1	9.60	32800	40	52	60	7.20	24600	34.6	45	45
BAYHTR3410 000	1/3	9.60	32800	34.6	43	45	7.20	24600	30	37	40
BAYHTR1415 BRK	2/1	15.36	52400	40/24	52*/30	60*/30	11.53	39300	34.6/20.8	45*/26	45*/30
BAYHTR1415 BRK with Single Circuit Power Source Kit BAYSPEK140B	1/1	15.36	52400	64	90	90	11.53	39300	55.4	79	80
BAYHTR3415 000	1/3	15.36	52400	39.5	49	50	11.53	39300	34.4	43	45

NOTES:  
 \* Circuit 1/Circuit 2 (Minimum Circuit Ampacity for Circuit 1 includes Blower Motor Amps)  
 +++ = 000, BRK, PDC 000 = pigtails, BRK = contains circuit breakers, PDC= contains pull disconnect

IMPORTANT: Any power supply and/or combination power supply, circuit or circuits must be wired and protected in accordance with local Electrical Codes.

4TEC3F36B WIRING DATA (Indoor Blower Motor Powered from Heater Circuit 1)											
Heater Model No.	Number of Circuits/Phase	240 VOLT					208 VOLT				
		Capacity		Heater Amps per Circuit	Minimum Circuit Ampacity	Maximum Overload Protection	Capacity		Heater Amps per Circuit	Minimum Circuit Ampacity	Maximum Overload Protection
		KW	BTUH				KW	BTUH			
NONE	1/1	N/A	N/A	N/A	3	15	N/A	N/A	N/A	3	15
BAYHTR1405+++	1/1	4.80	16400	20	28	30	3.60	12300	17.3	24	25
BAYHTR1408+++	1/1	7.68	26200	32	43	45	5.76	19700	27.7	37	40
BAYHTR1410 +++	1/1	9.60	32800	40	53	60	7.20	24600	34.6	46	50
BAYHTR3410 000	1/3	9.60	32800	34.6	43	45	7.20	24600	30	37	40
BAYHTR1415 BRK	2/1	15.36	52400	40/24	53*/30	60*/30	11.53	39300	34.6/20.8	46*/26	50*/30
BAYHTR1415 BRK with Single Circuit Power Source Kit BAYSPEK140B	1/1	15.36	52400	64	90	90	11.53	39300	55.4	79	80
BAYHTR3415 000	1/3	15.36	52400	40	50	50	11.53	39300	34.9	44	45
BAYHTR1419 BRK	2/1	19.20	65500	32/48	43*/60	45*/60	14.42	49200	27.7/41.6	37*/52	40*/60
BAYHTR1419 BRK with Single Circuit Power Source Kit BAYSPEK140B	1/1	19.2	65500	80	110	110	14.42	49200	69.3	96	100

NOTES:  
 \* Circuit 1/Circuit 2 (Minimum Circuit Ampacity for Circuit 1 includes Blower Motor Amps)  
 +++ = 000, BRK, PDC 000 = pigtails, BRK = contains circuit breakers, PDC= contains pull disconnect

IMPORTANT: Any power supply and/or combination power supply, circuit or circuits must be wired and protected in accordance with local Electrical Codes.

# Electrical Data



4TEC3F42C WIRING DATA (Indoor Blower Motor Powered from Heater Circuit 1)											
Heater Model No.	Number of Circuits/Phase	240 VOLT					208 VOLT				
		Capacity		Heater Amps per Circuit	Minimum Circuit Ampacity	Maximum Overload Protection	Capacity		Heater Amps per Circuit	Minimum Circuit Ampacity	Maximum Overload Protection
		KW	BTUH				KW	BTUH			
NONE	1/1	N/A	N/A	N/A	4.1	15	N/A	N/A	N/A	4.1	15
BAYHTR1405 +++	1/1	4.80	16400	20	29	30	3.60	12300	17.3	26	30
BAYHTR1408 +++	1/1	7.68	26200	32	44	45	5.76	19700	27.7	39	40
BAYHTR1410 +++	1/1	9.60	32800	40	54	60	7.20	24600	34.6	47	50
BAYHTR3410 000	1/3	9.60	32800	34.6	43	45	7.20	24600	30	37	40
BAYHTR1415 BRK	2/1	15.36	52400	40/24	53*/30	60*/30	11.53	39300	34.6/20.8	47*/26	50*/30
BAYHTR1415 BRK with Single Circuit Power Source Kit BAYSPEK140B	1/1	15.36	52400	64	90	90	11.53	39300	55.4	79	80
BAYHTR3415 000	1/3	15.36	52400	41	51	60	11.53	39300	35.9	45	45
BAYHTR1419 BRK	2/1	19.20	65500	32/48	44*/60	45*/60	14.42	49200	27.7/41.6	39*/52	40*/60
BAYHTR1419 BRK with Single Circuit Power Source Kit BAYSPEK140B	1/1	19.2	65500	80	110	110	14.42	49200	69.3	96	100

NOTES:  
 \* Circuit 1/Circuit 2 (Minimum Circuit Ampacity for Circuit 1 includes Blower Motor Amps)  
 +++ = 000, BRK, PDC 000 = pigtails, BRK = contains circuit breakers, PDC = contains pull disconnect

IMPORTANT: Any power supply and/or combination power supply, circuit or circuits must be wired and protected in accordance with local Electrical Codes.

4TEC3F48B WIRING DATA (Indoor Blower Motor Powered from Heater Circuit *)											
Heater Model No.	Number of Circuits/Phase	240 VOLT					208 VOLT				
		Capacity		Heater Amps per Circuit	Minimum Circuit Ampacity	Maximum Overload Protection	Capacity		Heater Amps per Circuit	Minimum Circuit Ampacity	Maximum Overload Protection
		KW	BTUH				KW	BTUH			
NONE	1/1	N/A	N/A	N/A	3.4	15	N/A	N/A	N/A	3.4	15
BAYHTR1405 +++	1/1	4.80	16400	20	28	30	3.60	12300	17.3	25	25
BAYHTR1408 +++	1/1	7.68	26200	32	43	45	5.76	19700	27.7	38	40
BAYHTR1410 +++	1/1	9.60	32800	40	53	60	7.20	24600	34.6	47	50
BAYHTR1415 BRK	2/1	15.36	52400	40/24	53*/30	60*/30	11.53	39300	34.6/20.8	47*/26	50*/30
BAYHTR1415 BRK with Single Circuit Power Source Kit BAYSPEK140B	1/1	15.36	52400	64	90	90	11.53	39300	55.4	79	80
BAYHTR3410 000	1/3	9.60	32800	34.6	43	45	7.20	24600	30.0	37	40
BAYHTR3415 000	1/3	15.36	52400	38.2	51	60	11.53	39300	33.1	44	45
BAYHTR1419 BRK	2/1	19.20	65500	32/48	43*/60	45*/60	14.42	49200	27.7/41.6	38*/52	40*/60
BAYHTR1419 BRK with Single Circuit Power Source Kit BAYSPEK140B	1/1	19.2	65500	80	110	110	14.42	49200	69.3	96	100

NOTES:  
 \* Circuit 1/Circuit 2 (Minimum Circuit Ampacity for Circuit 1 includes Blower Motor Amps)  
 +++ = 000, BRK, PDC 000 = pigtails, BRK = contains circuit breakers, PDC = contains pull disconnect

IMPORTANT: Any power supply and/or combination power supply, circuit or circuits must be wired and protected in accordance with local Electrical Codes.



# Electrical Data

4TEC3F60B WIRING DATA (Indoor Blower Motor Powered from Heater Circuit *)												
Heater Model No.	Number of Circuits/Phase	240 VOLT					208 VOLT					
		Capacity		Heater Amps per Circuit	Minimum Circuit Ampacity	Maximum Overload Protection	Capacity		Heater Amps per Circuit	Minimum Circuit Ampacity	Maximum Overload Protection	
		KW	BTUH				KW	BTUH				
NONE	1/1	N/A	N/A	N/A	9.5	15	N/A	N/A	N/A	9.5	15	
BAYHTR1405 +++	1/1	4.80	16400	20	35	35	3.60	12300	17.3	31	35	
BAYHTR1408 +++	1/1	7.68	26200	32	50	50	5.76	19700	27.7	44	45	
BAYHTR1410 +++	1/1	9.60	32800	40	60	60	7.20	24600	34.6	53	60	
BAYHTR1415 BRK	2/1	15.36	52400	40/24	60*/30	60*/30	11.53	39300	34.6/20.8	53*/26	60*/30	
BAYHTR1415 BRK with Single Circuit Power Source Kit BAYSPEK140B	1/1	15.36	52400	64	90	90	11.53	39300	55.4	79	80	
BAYHTR3410 000	1/3	9.60	32800	34.6	43	45	7.20	24600	30.0	37	40	
BAYHTR3415 000	1/3	15.36	52400	44.7	56	60	11.53	39300	39.7	50	50	
BAYHTR1419 BRK	2/1	19.20	65500	32/48	50*/60	50*/60	14.42	49200	27.7/41.6	44*/52	45*/60	
BAYHTR1419 BRK with Single Circuit Power Source Kit BAYSPEK140B	1/1	19.2	65500	80	110	110	14.42	49200	69.3	96	100	

NOTES:  
 \* Circuit 1/Circuit 2 (Minimum Circuit Ampacity for Circuit 1 includes Blower Motor Amps)  
 +++ = 000, BRK, PDC 000 = pigtails, BRK = contains circuit breakers, PDC = contains pull disconnect

IMPORTANT: Any power supply and/or combination power supply, circuit or circuits must be wired and protected in accordance with local Electrical Codes.

# Electrical Data

## Unit Wiring Diagram 4TEC3F24-36B1000A

### WARNING

HAZARDOUS VOLTAGE!  
DISCONNECT ALL ELECTRICAL POWER INCLUDING REMOTE DISCONNECTS BEFORE SERVICING.  
Failure to disconnect power before servicing can cause severe personal injury or death.

### CAUTION

USE COPPER CONDUCTORS ONLY!  
UNIT TERMINALS ARE NOT DESIGNED TO ACCEPT OTHER TYPES OF CONDUCTORS.  
Failure to do so may cause damage to the equipment.

AIR FLOW SELECTION	
TERM	SPEED
A	LOW
B	MED
C	HIGH

### LEGEND

- 24 V.
- LINE V.
- ⊥ GROUND
- JUNCTION
- ⊢ CAPACITOR
- △ WIRE CONNECTOR
- TERMINAL
- ⊞ TRANSFORMER
- ⊞ FUSE
- ⊢ RELAY CONTACT NO
- ⊞ MAGNETIC COIL
- |   |   |   |
|---|---|---|
| 1 | 2 | 3 |
| ↓ | ↓ | ↓ |

 POL. PLUG FEMALE (MALE TERMINALS)
- |   |   |   |
|---|---|---|
| 1 | 2 | 3 |
| ↑ | ↑ | ↑ |

 POL. PLUG MALE (FEMALE TERMINALS)
- CN WIRE CONNECTOR
- CF FAN CAPACITOR
- F FAN RELAY
- FU FUSE
- PCB PRINTED CIRCUIT BOARD
- PF POLARIZED PLUG (FEMALE HOUSING)
- PM POLARIZED PLUG (MALE HOUSING)
- TNS TRANSFORMER
- |       |                             |    |        |    |        |
|-------|-----------------------------|----|--------|----|--------|
| ↖     | COLOR OF WIRE               |    |        |    |        |
| BK/BL | BLACK WIRE WITH BLUE MARKER |    |        |    |        |
| ↖     | COLOR OF MARKER             |    |        |    |        |
| BK    | BLACK                       | RD | RED    | OR | ORANGE |
| BL    | BLUE                        | WH | WHITE  | GR | GREEN  |
| BR    | BROWN                       | YL | YELLOW | PR | PURPLE |

200/230 V. 1 PH., 60 HZ.  
POWER SUPPLY PER  
LOCAL CODES

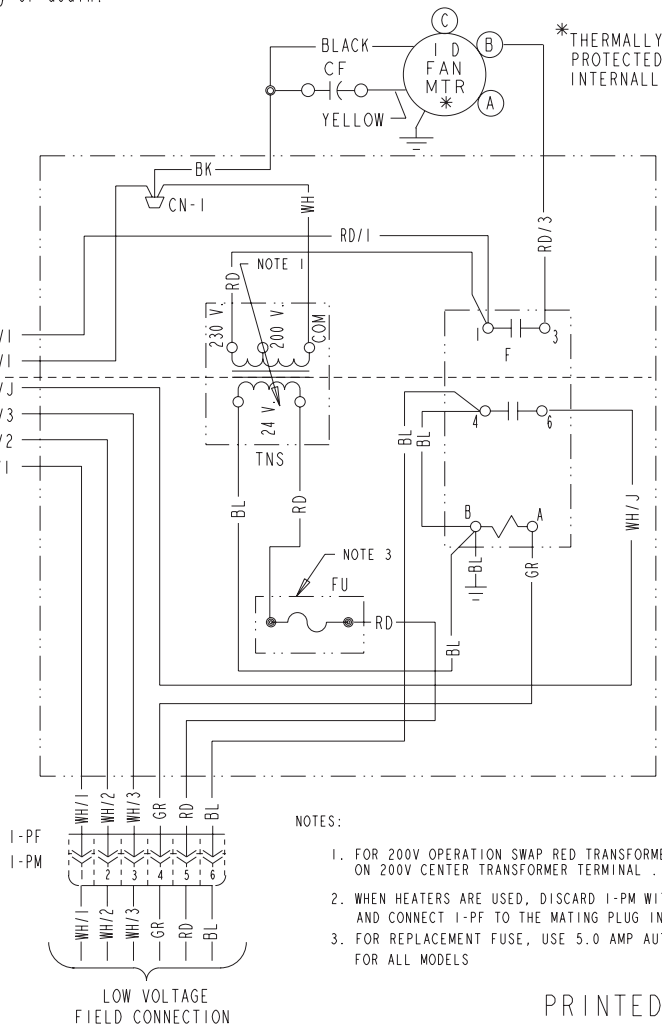
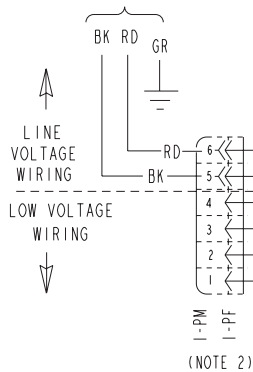

MODELS
TWE - P
2/4TEP-
2/4TEC3F18-36
2TGB3F18-36
TWG018-36

- NOTES:
- FOR 200V OPERATION SWAP RED TRANSFORMER LEAD AND INSULATED CAP ON 200V CENTER TRANSFORMER TERMINAL .
  - WHEN HEATERS ARE USED, DISCARD I-PM WITH ATTACHED LEADS AND CONNECT I-PF TO THE MATING PLUG IN THE HEATER CONTROL BOX.
  - FOR REPLACEMENT FUSE, USE 5.0 AMP AUTOMOTIVE STYLE FOR ALL MODELS

PRINTED FROM C800722P01 REV11



# Electrical Data

## Unit Wiring Diagram 4TEC3F42C1000A

### WARNING

**HAZARDOUS VOLTAGE!**  
DISCONNECT ALL ELECTRICAL POWER INCLUDING REMOTE DISCONNECTS BEFORE SERVICING.  
Failure to disconnect power before servicing can cause severe personal injury or death.

### CAUTION

USE COPPER CONDUCTORS ONLY!  
UNIT TERMINALS ARE NOT DESIGNED TO ACCEPT OTHER TYPES OF CONDUCTORS.  
Failure to do so may cause damage to the equipment.

### LEGEND

- 24 V.
- LINE V.
- ⊥ GROUND
- JUNCTION
- ⊢ CAPACITOR
- △ WIRE CONNECTOR
- TERMINAL
- ⊞ TRANSFORMER
- ⊞ FUSE
- ⊢ RELAY CONTACT NO
- ⊞ MAGNETIC COIL
- ⊞ POL. PLUG FEMALE (MALE TERMINALS)
- ⊞ POL. PLUG MALE (FEMALE TERMINALS)
- CN WIRE CONNECTOR
- CF FAN CAPACITOR
- F FAN RELAY
- FU FUSE
- PCB PRINTED CIRCUIT BOARD
- PF POLARIZED PLUG (FEMALE HOUSING)
- PM POLARIZED PLUG (MALE HOUSING)
- TNS TRANSFORMER
- COLOR OF WIRE
- BK/BL BLACK WIRE WITH BLUE MARKER
- COLOR OF MARKER
- BK BLACK RD RED OR ORANGE
- BL BLUE WH WHITE GR GREEN
- BR BROWN YL YELLOW PR PURPLE

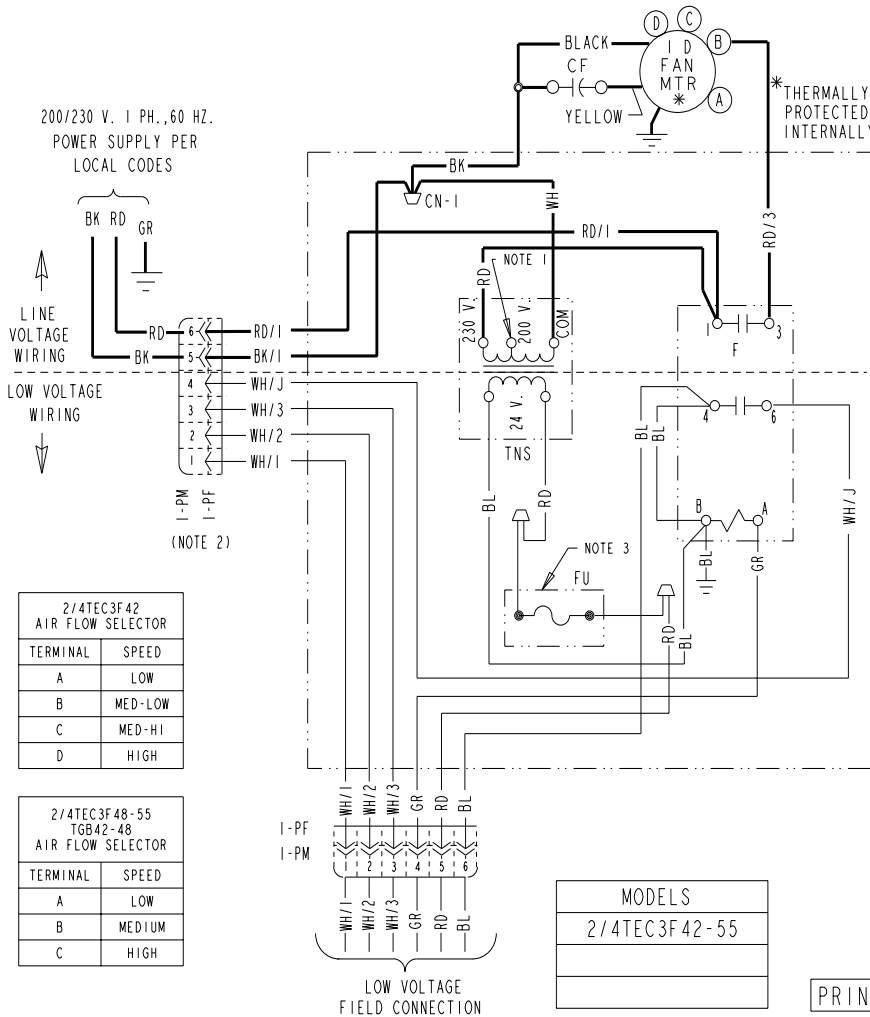

2/4TEC3F42 AIR FLOW SELECTOR	
TERMINAL	SPEED
A	LOW
B	MED-LOW
C	MED-HI
D	HIGH

2/4TEC3F48-55 TGB42-48 AIR FLOW SELECTOR	
TERMINAL	SPEED
A	LOW
B	MEDIUM
C	HIGH

MODELS
2/4TEC3F42-55

- NOTES:
1. FOR 200V OPERATION SWAP RED TRANSFORMER LEAD AND INSULATED CAP ON 200V CENTER TRANSFORMER TERMINAL .
  2. WHEN HEATERS ARE USED, DISCARD I-PM WITH ATTACHED LEADS AND CONNECT I-PF TO THE MATING PLUG IN THE HEATER CONTROL BOX.
  3. FOR REPLACEMENT FUSE, USE LITTLEFUSE LMF 3-2/10 OR BUSSMAN GMD 3-2/10 FOR ALL MODELS.

PRINTED FROM D802442P01 REV01

NOTE: Motor Speed Tap # 5 must be selected if a time delay function is required.



# Electrical Data

## Unit Wiring Diagram 4TEC3F60B1000A

**WARNING**

HAZARDOUS VOLTAGE!  
DISCONNECT ALL ELECTRICAL POWER INCLUDING REMOTE DISCONNECTS BEFORE SERVICING.  
Failure to disconnect power before servicing can cause severe personal injury or death.

**CAUTION**

USE COPPER CONDUCTORS ONLY!  
UNIT TERMINALS ARE NOT DESIGNED TO ACCEPT OTHER TYPES OF CONDUCTORS.  
Failure to do so may cause damage to the equipment.

AIR FLOW SELECTION	
TERM	SPEED
1	LOW
2	MED-LO
3	MED-HI
4	HIGH
5	NOTE 4

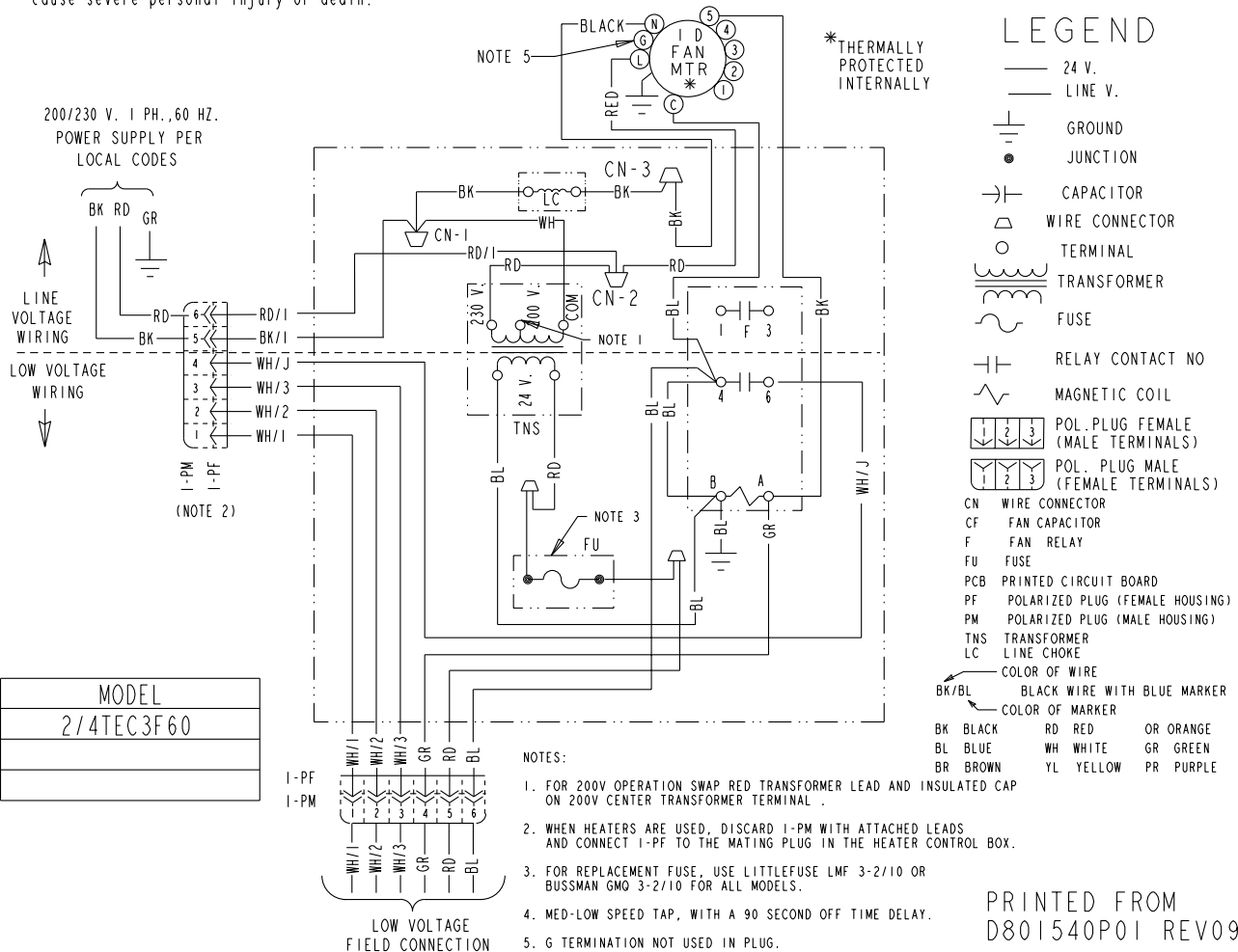

# Field Wiring

## Air Handler with Single Speed Cooling Unit, 2 Stage Heat

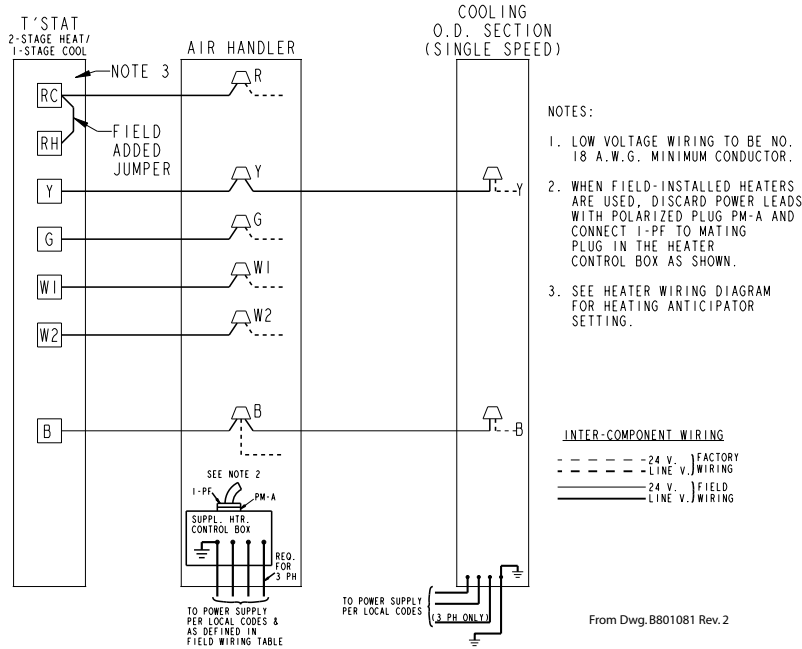

## Air Handlers with Single Speed Cooling Unit, 1 Stage Heat

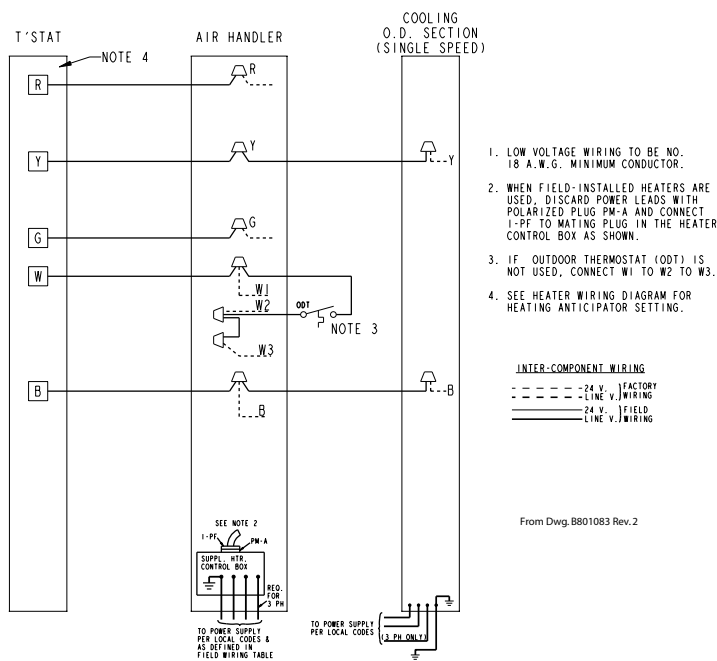

# Field Wiring

## Field Wiring Diagrams for Air Handlers with Heat Pump

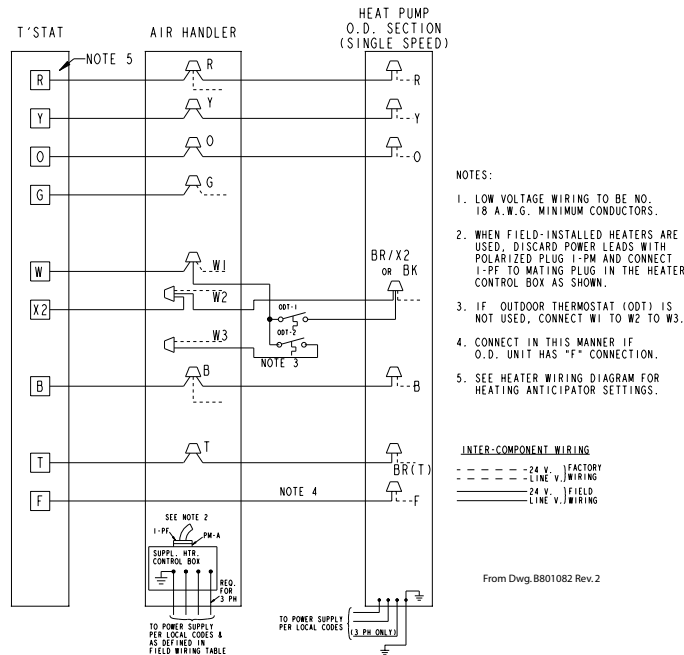

## Air Handler Subbase

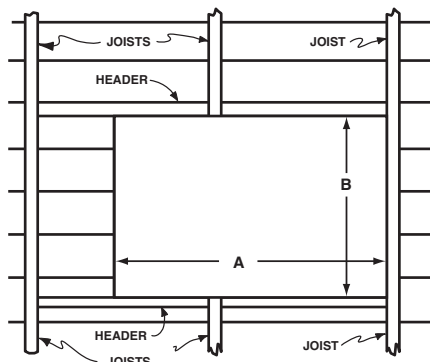

FIG. 2

FLOOR OPENING - SIZE		
MODEL NO.	A	B
TAYBASE100	23-3/4	14-13/16
TAYBASE101	21-3/4	14-13/16
TAYBASE102	26-3/4	14-13/16

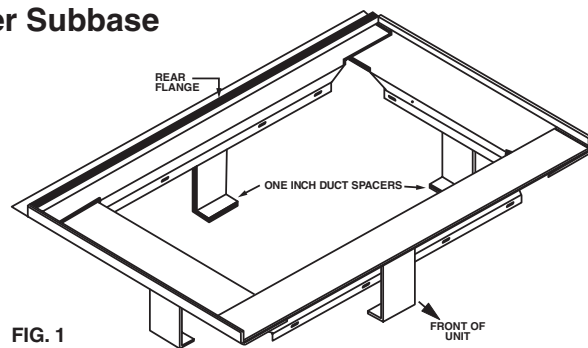

FIG. 1

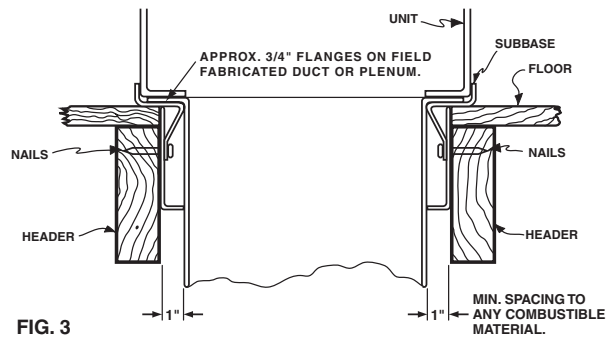

FIG. 3

# 4TEC3F24-60 Convertibility

## Six (6) Way Convertibility

### One Unit - 4 Applications (Conversions 1-4)

#### Horizontal Right (as shipped)

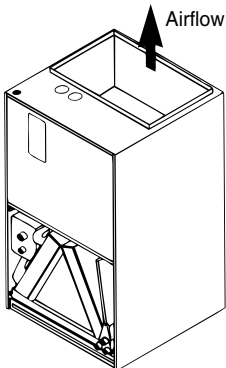
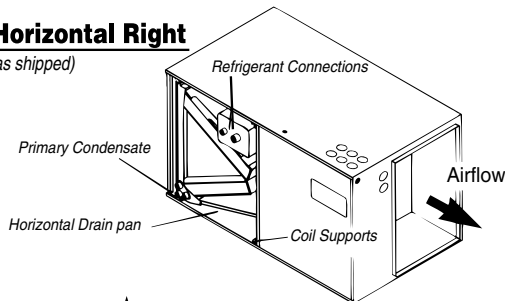

#### Vertical Upflow

(as shipped)  
One-step Conversion  
Stand unit on end

#### Horizontal Left Rotate Coil

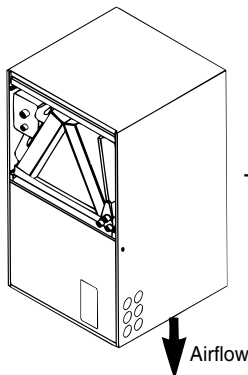
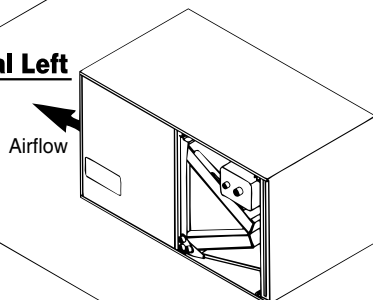

#### Vertical Downflow

One-step Conversion  
from Horizontal left

### Easy Conversion to Opposite Side Access (Conversions 5 & 6)

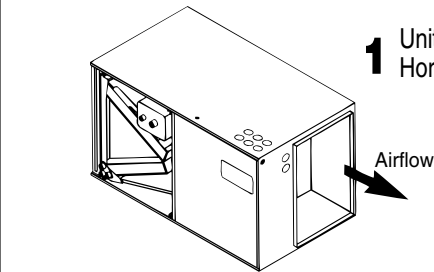

**1** Unit is shipped as Horizontal right

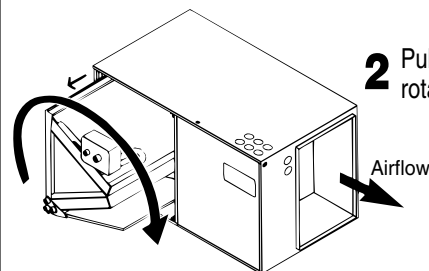

**2** Pull coil out and rotate the coil 180°

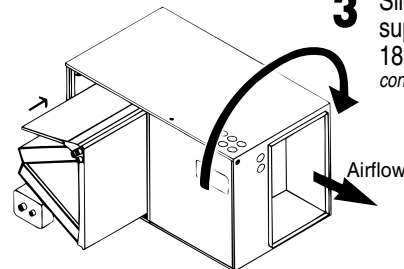

**3** Slide coil back in on supports and roll unit 180° (so primary condensate is down)

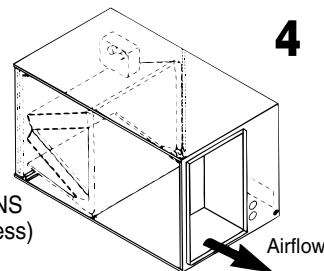

**4** Note connections and access are now on back side of unit

- 6 CONVERSION APPLICATIONS
1. Horizontal Right - (Front Access)
  2. Vertical Upflow
  3. Horizontal Left - (Front Access)
  4. Vertical Downflow
  5. Horizontal Right - (Rear Access)
  6. Horizontal Left - (Rear Access)



# Mechanical Specification Options

## General

Blower coil units shall be completely factory assembled including coil, condensate drain pan, fan, motor, filters and controls in an insulated casing that can be applied in horizontal or vertical configuration. The "F" model indicates an "Air-Tite™" model with 4.2 "R" value insulation and additional sealing systems.

This line of 4TEC3F Air Handlers provides exclusive compact size combined with simple 6-way convertibility in sizes up to 5 Tons. The unit ships in the vertical upflow configuration and converts to horizontal right just by laying the unit on its side. No tools required. Simple coil rotation provides downflow and horizontal left applications.

The 6-way convertibility provides you inventory benefits and service/installation flexibility. The simple conversion provides opposite side access for installation and service.

These Air Handlers enjoy the best reputation in the industry. Superior airflow, great sound level, reliability and performance are responsible for the industry leadership. We are not about to give up such top performance.

Units shall be certified to UL 1995.

## Casing

Units shall have a rugged sheet metal and steel frame construction and shall be painted with an enamel finish. Casing shall be insulated and knockouts for electrical power and control wiring.

## Refrigerant Circuits

The 4TEC3F units have a single refrigerant circuit. 4TEC3F24-60 refrigerant circuit shall be controlled by a factory-installed non-bleed thermal expansion valve.

## Coil

Aluminum fin surface shall be mechanically bonded to 3/8-inch OD copper tubing. Coils are factory pressure and leak tested.

## Fan

Forward curved, dynamically balanced and statically balanced with 3-speed direct drive shall be standard, fan motor bearing shall be permanently lubricated.

## Controls

Low voltage pig tails, fan contactor, and plug-in module for accessory electric heat control shall be included.

## Filters

Filters shall be included as standard, one-inch low velocity semi-permanent type (except 5-ton - washable filter).

## Accessories

**Electric Heaters** — Shall be available in a wide range of capacities and voltages with various staging options, and plug-in control wiring. Heaters shall fit inside the internal compartment.



Intertek



Trane  
6200 Troup Highway  
Tyler, TX 75707  
www.trane.com

06/12

The manufacturer has a policy of continuous product and product data improvement and it reserves the right to change design and specifications without notice.