



**TRANE®**

# Modular Variable Speed Air Handlers

---

2TEE3F31A1000A  
2TEE3F37A1000A  
2TEE3F39A1000A  
2TEE3F40A1000A  
2TEE3F48A1000A  
2TEE3F49A1000A  
2TEE3F64A1000A  
2TEE3F65A1000A

4TEE3F31B1000A  
4TEE3F37B1000A  
4TEE3F39A1000A  
4TEE3F40B1000A  
4TEE3F48A1000A  
4TEE3F49B1000A  
4TEE3F64A1000A  
4TEE3F65B1000A

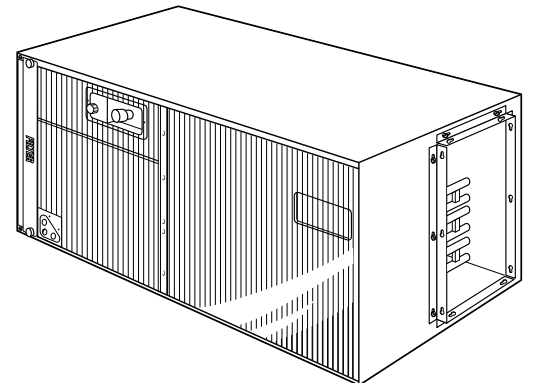
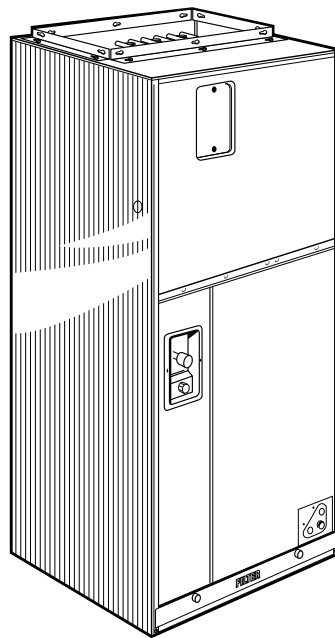

---

**PUB. NO. 22-1717-06**



## Features and Benefits

- Ships vertical - converts to horizontal by laying unit on side.
- Six-way convertibility – horizontal (left & right), front & rear access; upflow, downflow
- Electrical, refrigerant, condensate & blower access convertible to either side
- Compact 21" depth for easy installation
- Variable speed ECM motor
- 3.5, 4, and 5 ton models available in 26" widths or with Vortica™ in 23.5" widths
- Direct drive blower
- **Comfort-R™** enhanced dehumidification cycle
- Soft Start - On cycle fan speed is increased gradually to reduce sound and drafts
- Corrosion resistant galvanized metal with attractive finish
- Expansion valve refrigerant control
- Check valve for heat pump application
- Internally enhanced finned coil tubing
- External brazed refrigerant connections
- Filter rack with standard size filter
- 200/230 volt primary & 24 volt secondary transformer
- Low voltage terminal board
- Uses 1400 series heaters
- Access to heater circuit breakers
- Polarized plugs for making motor and transformer electrical connections from air handler control box to electric heaters
- Primary and secondary drain connections
- Easy Air-Tite™ access to coils
- Built-in indoor fan delay function for increased efficiency
- 2/4TEE3F31 airflow selectable for 1-1/2 — 3 ton O.D. unit
- 2/4TEE3F37, 39, 40 airflow selectable for 2 — 3-1/2 ton O.D. unit
- 2/4TEE3F48, 49 airflow selectable for 3 — 5 ton O.D. unit
- 2/4TEE3F64, 65 airflow selectable for 3 — 5 ton O.D. unit
- Energy-saving continuous fan
- Enhanced cooling/heating control

## Optional Equipment

### OPTIONAL EQUIPMENT FOR AIR HANDLERS (Check mark [✓] indicates accessories included).

Plenum — Pedestal (2/4TEE3F37, 39, 40, 48, 49, 64, 65) .....	TAYPLNM100 [ ]
Sub-base For Downflow (2/4TEE3F31) .....	TAYBASE101 [ ]
Sub-base For Downflow (2/4TEE3F37, 39, 48, 64) .....	TAYBASE100 [ ]
Sub-base For Downflow (2/4TEE3F40, 49, 65) .....	TAYBASE102 [ ]
Evaporator Defrost Control Kit — Cooling Units (Low Ambient Cooling) .....	AY28X079 [ ]
Evaporator Defrost Control Kit — Heat Pumps (Low Ambient Cooling) .....	AY28X084 [ ]
Knockout cover plate (2/4TEE3F31, 37, 40, 49, 65) .....	BAY99X123 [ ]
Humidistat .....	BAYSTAT253 [ ]



# Contents

---

<b>Features and Benefits</b>	<b>2</b>
Optional Equipment	2
<b>“Air-Tite™” Features and Benefits</b>	<b>4</b>
<b>General Data</b>	<b>5</b>
2TEE3F31A1000A      4TEE3F31B1000A	5
2TEE3F37A1000A      4TEE3F37B1000A	5
2TEE3F39A1000A      4TEE3F39A1000A	5
2TEE3F40A1000A      4TEE3F40B1000A	5
2TEE3F48A1000A      4TEE3F48A1000A	5
2TEE3F49A1000A      4TEE3F49B1000A	6
2TEE3F64A1000A      4TEE3F64A1000A	6
2TEE3F65A1000A      4TEE3F65B1000A	6
<b>Performance Data</b>	<b>7</b>
<b>Electrical Data</b>	<b>20</b>
<b>Field Wiring</b>	<b>21</b>
<b>Convertibility</b>	<b>22</b>
<b>Dimensions</b>	<b>23</b>
<b>Mechanical Specification Options</b>	<b>26</b>



**TRANE®**

# “Air-Tite™” Features and Benefits

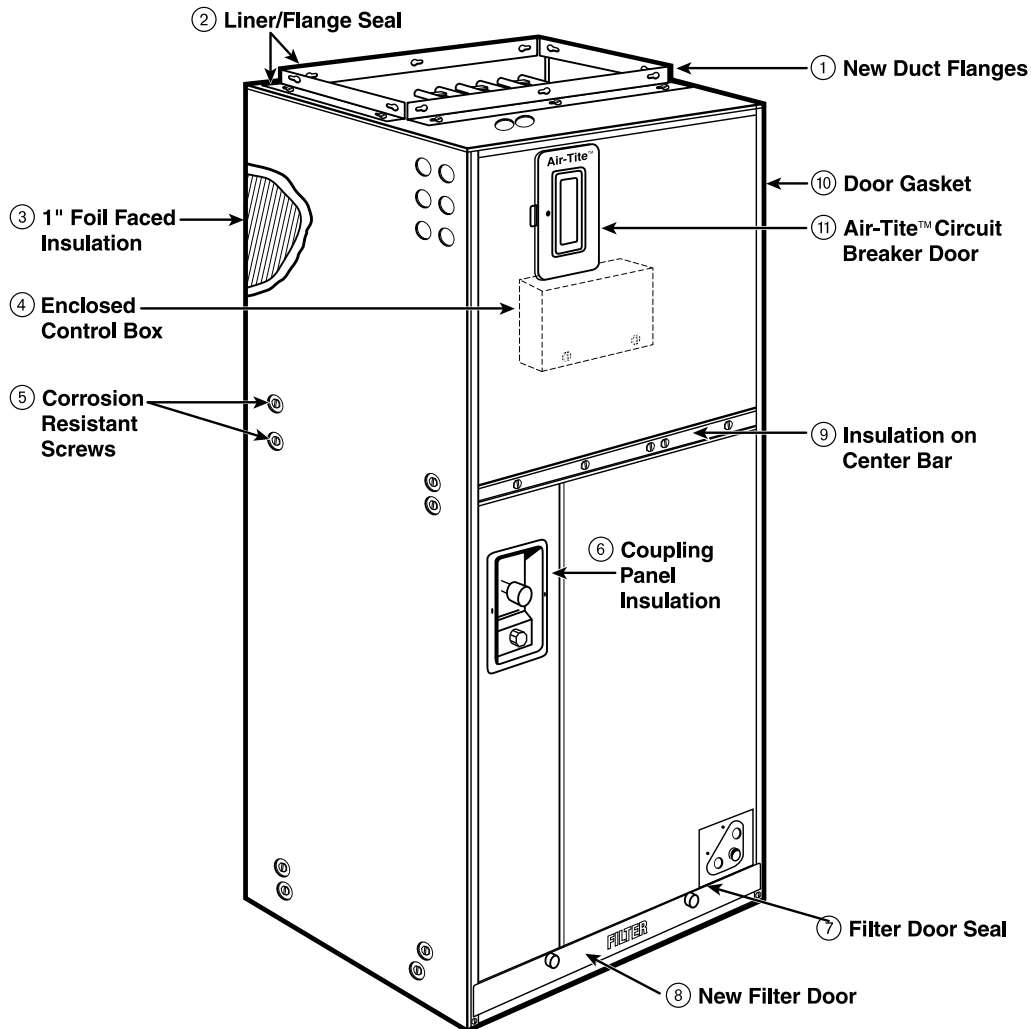

- ① **New Duct Flange** – Allows flush fit for 3/4", 1" or 1 1/2" duct insulation.
- ② **Liner/Flange Seal** – Exclusive Duct Flange Thermal Break/ Seal and double wall construction to reduce cabinet loss and sweating.
- ③ **1" Foil Faced Insulation** – Thicker foil faced insulation for reduced cabinet loss, sweating and lower power bills.
- ④ **Enclosed Control Box** – Totally enclosed control box with transformer inside to improve component life, unit durability and reliability.
- ⑤ **Corrosion Resistant Screws** – Exclusive “Weatherguard™” coated screws to maintain the quality appearance of the unit for the life of the product.
- ⑥ **Coupling Panel Insulation** – Exclusive “No Burn” refrigerant coupling panel with thicker insulation for reduced heat loss.

- ⑦ **Filter Door Seal** – Improved door seal for reduced air infiltration, heat transfer, and lower power bills.
- ⑧ **New Filter Door** – “Filter” is stamped on the panel, and includes two captive screws with easy grip knobs.
- ⑨ **Insulation on Center Bar** – Exclusive center bar insulation for reduced cabinet loss, sweating and lower power bills.
- ⑩ **Door Gasket** – Exclusive formed gasket (similar to a car door gasket) to reduce air infiltration and heat transfer and lower power bills.
- ⑪ **Air-Tite™ Circuit Breaker Door** – Easy access to breakers with positive air seal.

The SEER test for system efficiency places the air handler in the ambient return air stream (80°F). If your air handler is to be in an unconditioned/severe climatic location you should consider the advantages of the “Air-Tite™” model air handler.



# General Data

MODEL	2TEE3F31A1000A 4TEE3F31B1000A	2TEE3F37A1000A 4TEE3F37B1000A	2TEE3F39A1000A 4TEE3F39A1000A
<b>RATED VOLTS/PH/Hz.</b>	200-230/1/60	200-230/1/60	200-230/1/60
<b>RATINGS</b> ①	See O.D. Specifications	See O.D. Specifications	See O.D. Specifications
<b>INDOOR COIL</b> — Type	Plate Fin	Plate Fin	Plate Fin
Rows — F.P.I.	3 — 14	3 — 14	3 — 14
Face Area (sq. ft.)	3.21	3.9	5.04
Tube Size (in.)	3/8 - Copper	3/8 - Copper	3/8 - Copper
Refrigerant Control	TXV - NonBleed	TXV - NonBleed	TXV - NonBleed
Drain Conn. Size (in.) ②	3/4 NPT	3/4 NPT	3/4 NPT
<b>INDOOR FAN</b> — Type	Centrifugal	Centrifugal	Centrifugal
Diameter-Width (In.)	10 x 8	10 x 10	11 x 10
No. Used	1	1	1
Drive - No. Speeds	Direct - 16	Direct - 16	Direct - 16
CFM vs. in. w.g. ①	See Fan Performance Table	See Fan Performance Table	See Fan Performance Table
No. Motors — H.P.	1 — 1/2	1 — 1/2	1 — 1/2
Motor Speed R.P.M.	Variable	Variable	Variable
Volts/Ph/Hz	200-230/1/60	200-230/1/60	200-230/1/60
F.L. Amps - L.R. Amps	4.3	4.3	4.3
<b>FILTER</b>			
<b>Vertical Applications</b>			
Filter Furnished?	Yes	Yes	Yes
Type Recommended	Low Velocity	Low Velocity	Throwaway
No.-Size-Thickness	1 - 20 X 20 - 1 in.	1 - 20 X 20 - 1 in.	1 - 20 X 20 - 1 in.
<b>Horizontal Applications</b>			
Filter Furnished?	No	No	No
Recommended Size	See Note ③④	See Note ③④	See Note ③④
<b>REFRIGERANT</b>	R-22 R-410A	R-22 R-410A	R-22 R-410A
Ref. Line Connections	Brazed Brazed	Brazed Brazed	Brazed Brazed
Conn. Size — in. Gas	3/4 3/4	7/8 3/4	7/8 3/4
Conn. Size — in. Liq.	5/16 5/16	3/8 3/8	3/8 3/8
<b>DIMENSIONS</b>	H x W x D	H x W x D	H x W x D
Crated (In.)	44-1/2 x 24 x 23-1/2	47-7/8 x 26 x 23-1/2	59-1/2 x 26 x 23-1/2
Uncrated	See Outline Drawing	See Outline Drawing	57-7/8 x 23-1/2 x 21
<b>WEIGHT</b>	134 / 118	142 / 127	160 / 150

MODEL	2TEE3F40A1000A 4TEE3F40B1000A	2TEE3F48A1000A 4TEE3F48A1000A
<b>RATED VOLTS/PH/Hz.</b>	200-230/1/60	200-230/1/60
<b>RATINGS</b> ①	See O.D. Specifications	See O.D. Specifications
<b>INDOOR COIL</b> — Type	Plate Fin	Plate Fin
Rows — F.P.I.	4 — 14	3 — 14
Face Area (sq. ft.)	5.04	6.19
Tube Size (in.)	3/8 - Copper	3/8 - Copper
Refrigerant Control	TXV - NonBleed	TXV - NonBleed
Drain Conn. Size (in.) ②	3/4 NPT	3/4 NPT
<b>INDOOR FAN</b> — Type	Centrifugal	Centrifugal
Diameter-Width (In.)	10 x 10	11 x 10
No. Used	1	1
Drive - No. Speeds	Direct - 16	Direct - 16
CFM vs. in. w.g. ①	See Fan Performance Table	See Fan Performance Table
No. Motors — H.P.	1 — 1/2	1 — 3/4
Motor Speed R.P.M.	Variable	Variable
Volts/Ph/Hz	200-230/1/60	200-230/1/60
F.L. Amps - L.R. Amps	4.3	6.8
<b>FILTER</b>		
<b>Vertical Applications</b>		
Filter Furnished?	Yes	Yes
Type Recommended	Low Velocity	Throwaway
No.-Size-Thickness	1 - 20 X 25 - 1 in.	1 - 20 X 20 x 1 in.
<b>Horizontal Applications</b>		
Filter Furnished?	No	No
Recommended Size	See Note ③④	See Note ③④
<b>REFRIGERANT</b>	R-22 R-410A	R-22 R-410A
Ref. Line Connections	Brazed Brazed	Brazed Brazed
Conn. Size — in. Gas	7/8 3/4	1-1/8 7/8
Conn. Size — in. Liq.	3/8 3/8	3/8 3/8
<b>DIMENSIONS</b>	H x W x D	H x W x D
Crated (In.)	54-1/2 x 28-1/2 x 23-1/2	59-1/2 x 26 x 23-1/2
Uncrated	See Outline Drawing	57-7/8 x 23-1/2 x 21
<b>WEIGHT</b>	174 / 155	170/155

- ① These Air Handlers are A.R.I. certified with various Split System Air Conditioners and Heat Pumps (ARI STANDARD 210/240). Refer to the Split System Outdoor Unit Product Data Guides for performance data.
- ② 3/4" Male Plastic Pipe (Ref.: ASTM 1785-76)
- ③ Minimum filter size for horizontal applications will be based on airflow selection and will be calculated as follows:  
Low Velocity Filter:  
Face area (Sq. Ft.) = CFM / 300  
High Velocity Filter:  
Face area (Sq. Ft.) = CFM / 500
- ④ For customer ease of filter maintenance, it is recommended that a properly sized, remote filter and grille be installed for horizontal applications. Airflow should not exceed the face value of the filter being used. The factory installed filter should then be removed from the unit.



**TRANE®**

# General Data

MODEL	2TEE3F49A1000A 4TEE3F49B1000A		2TEE3F64A1000A 4TEE3F64A1000A		2TEE3F65A1000A 4TEE3F65B1000A	
<b>RATED VOLTS/PH/HZ.</b>	200-230/1/60		200-230/1/60		200-230/1/60	
<b>RATINGS</b> ①	See O.D. Specifications		See O.D. Specifications		See O.D. Specifications	
<b>INDOOR COIL</b> — Type	Plate Fin		Plate Fin		Plate Fin	
Rows — F.P.I.	4 — 14		3 — 14		4 — 14	
Face Area (sq. ft.)	6.19		6.19		7.33	
Tube Size (in.)	3/8 - Copper		3/8 - Copper		3/8 - Copper	
Refrigerant Control	TXV - NonBleed		TXV - NonBleed		TXV - NonBleed	
Drain Conn. Size (in.) ②	3/4 NPT		3/4 NPT		3/4 NPT	
<b>INDOOR FAN</b> — Type	Centrifugal		Centrifugal		Centrifugal	
Diameter-Width (In.)	10 x 10		11 x 10		10 x 10	
No. Used	1		1		1	
Drive - No. Speeds	Direct - 16		Direct - 16		Direct - 16	
CFM vs. in. w.g. ①	See Fan Performance Table		See Fan Performance Table		See Fan Performance Table	
No. Motors — H.P.	1 — 3/4		1 — 1		1 — 1	
Motor Speed R.P.M.	Variable		Variable		Variable	
Volts/Ph/Hz	200-230/1/60		200-230/1/60		200-230/1/60	
F.L. Amps - L.R. Amps	6.8		7.0		7.0	
<b>FILTER</b>						
<b>Vertical Applications</b>						
Filter Furnished?	Yes		Yes		Yes	
Type Recommended	Throwaway		Low Velocity		Low Velocity	
No.-Size-Thickness	1 - 20 x 25 x 1 in.		1 - 20 X 22 - 1 in.		1 - 20 X 25 - 1 in.	
<b>Horizontal Applications</b>						
Filter Furnished?	No		No		No	
Recommended Size	See Note ③④		See Note ③④		See Note ③④	
<b>REFRIGERANT</b>	R-22	R-410A	R-22	R-410A	R-22	R-410A
Ref. Line Connections	Brazed	Brazed	Brazed	Brazed	Brazed	Brazed
Conn. Size — in. Gas	1-1/8	7/8	1-1/8	7/8	1-1/8	7/8
Conn. Size — in. Liq.	3/8	3/8	3/8	3/8	3/8	3/8
<b>DIMENSIONS</b>	H x W x D		H x W x D		H x W x D	
Crated (In.)	60-7/6 x 28-1/2 x 23-1/2		59-1/2 x 26 x 23-1/2		65-7/8 x 28-1/2 x 23-1/2	
Uncrated	See Outline Drawing		57-7/8 x 23-1/2 x 21		See Outline Drawing	
<b>WEIGHT</b>	188/173		170 / 155		218 / 196	

① These Air Handlers are A.R.I. certified with various Split System Air Conditioners and Heat Pumps (ARI STANDARD 210/240). Refer to the Split System Outdoor Unit Product Data Guides for performance data.

② 3/4" Male Plastic Pipe (Ref.: ASTM 1785-76)

③ Minimum filter size for horizontal applications will be based on airflow selection and will be calculated as follows:

Low Velocity Filter: Face area (Sq. Ft.) = CFM / 300

High Velocity Filter: Face area (Sq. Ft.) = CFM / 500

④ For customer ease of filter maintenance, it is recommended that a properly sized, remote filter and grille be installed for horizontal applications. Airflow should not exceed the face value of the filter being used. The factory installed filter should then be removed from the unit.



# Performance Data

## 2/4TEE3F31 AIRFLOW PERFORMANCE TABLE

AIRFLOW PERFORMANCE 2TEE3F31A, 4TEE3F31B WITH WET COIL, FILTER, NO HEATER													
OUTDOOR UNIT SIZE (TONS)	Speed Settings	AIRFLOW SETTING	DIP SWITCH SETTING				Airflow Power	EXTERNAL STATIC PRESSURE					
			SW 1	SW 2	SW 3	SW 4		0.1	0.2	0.3	0.5	0.7	0.9
1.5	Low	350 CFM/ton	ON	ON	OFF	ON	CFM Watts	565 75	560 85	550 98	525 135	495 175	450 200
	Normal	400 CFM/ton	ON	ON	OFF	OFF	CFM Watts	640 90	640 110	640 130	615 155	570 180	545 200
	High	450 CFM/ton	ON	ON	ON	OFF	CFM Watts	710 110	710 130	700 140	685 175	665 190	630 220
2	Low	350 CFM/ton	OFF	ON	OFF	ON	CFM Watts	745 120	740 135	730 150	710 190	690 215	665 245
	Normal	400 CFM/ton	OFF	ON	OFF	OFF	CFM Watts	835 145	840 165	845 190	840 230	820 265	795 295
	High	450 CFM/ton	OFF	ON	ON	OFF	CFM Watts	940 195	940 220	940 245	930 285	915 320	900 350
2.5	Low	350 CFM/ton	ON	OFF	OFF	ON	CFM Watts	885 170	890 200	890 230	890 270	880 300	860 345
	Normal	400 CFM/ton	ON	OFF	OFF	OFF	CFM Watts	1020 235	1020 255	1020 275	1015 320	1010 370	995 425
	High	450 CFM/ton	ON	OFF	ON	OFF	CFM Watts	1130 300	1130 335	1130 365	1130 420	1125 475	1115 505
3.0	Low	350 CFM/ton	OFF	OFF	OFF	ON	CFM Watts	1060 270	1060 300	1060 320	1055 360	1045 405	1030 460
	Normal **	400 CFM/ton	OFF	OFF	OFF	OFF	CFM Watts	1220 365	1220 400	1220 435	1220 485	1200 530	1030 550
	High	450 CFM/ton	OFF	OFF	ON	OFF	CFM Watts	1370 510	1370 545	1370 575	1295 615	1200 600	1030 530

NOTES:  
 1. \*\* Factory Setting  
 2. At continuous fan setting: Airflow values are approximately 50% of the listed values.

2TEE3F31A / 4TEE3F31B Airflow Performance with Auxiliary Heat				
Airflow Settings	Dip Switch Settings		Nominal Airflow	See Following Tables for heater application: -Pressure Drop for Electric Heaters -Minimum Heating Airflow Heater Matrix (on unit nameplates)
	Switch 7	Switch 8		
Low	ON	ON	700	
Med -Lo	OFF	ON	1000	
Med-Hi**	ON	OFF	1125	
High	OFF	OFF	1350	



**TRANE®**

# Performance Data

**2/4TEE3F37 AIRFLOW PERFORMANCE TABLE**

AIRFLOW PERFORMANCE 2TEE3F37A, 4TEE3F37B WITH WET COIL, FILTER, NO HEATER												
OUTDOOR UNIT SIZE (TONS)	Speed Settings	AIRFLOW SETTING	DIP SWITCH SETTING				Airflow Power	EXTERNAL STATIC PRESSURE				
			SW 1	SW 2	SW 3	SW 4		0.1	0.3	0.5	0.7	0.9
2	Low	350 CFM/ton	ON	ON	OFF	ON	CFM Watts	700 90	700 115	700 155	700 190	660 220
	Normal	400 CFM/ton	ON	ON	OFF	OFF	CFM Watts	800 110	800 140	800 180	770 230	750 260
	High	450 CFM/ton	ON	ON	ON	OFF	CFM Watts	900 130	900 165	900 220	900 265	900 310
2.5	Low	350 CFM/ton	OFF	ON	OFF	ON	CFM Watts	880 130	880 165	880 215	880 265	880 305
	Normal	400 CFM/ton	OFF	ON	OFF	OFF	CFM Watts	1000 165	1000 215	1000 270	1000 315	880 325
	High	450 CFM/ton	OFF	ON	ON	OFF	CFM Watts	1125 225	1125 285	1125 330	1100 380	900 340
3	Low	350 CFM/ton	ON	OFF	OFF	ON	CFM Watts	1040 170	1040 230	1040 280	1040 330	1000 325
	Normal	400 CFM/ton	ON	OFF	OFF	OFF	CFM Watts	1160 240	1160 300	1160 350	1100 385	870 335
	High	450 CFM/ton	ON	OFF	ON	OFF	CFM Watts	1300 325	1300 365	1260 425	1140 410	950 330
3.5	Low	350 CFM/ton	OFF	OFF	OFF	ON	CFM Watts	1225 295	1225 330	1200 385	1070 390	890 340
	Normal**	400 CFM/ton	OFF	OFF	OFF	OFF	CFM Watts	1350 365	1350 420	1280 455	1140 415	940 365
	High	450 CFM/ton	OFF	OFF	ON	OFF	CFM Watts	1400 405	1400 475	1300 460	1150 430	940 375

NOTES:  
 1. \*\* Factory Setting  
 2. At continuous fan setting: Airflow values are approximately 50% of the listed values.

2TEE3F37A / 4TEE3F37B Airflow Performance with Auxiliary Heat				
Airflow Settings	Dip Switch Settings		Nominal Airflow	See Following Tables for heater application: -Pressure Drop for Electric Heaters -Minimum Heating Airflow Heater Matrix (on unit nameplates)
	Switch 7	Switch 8		
Low	ON	ON	600	
Med -Lo	OFF	ON	900	
Med-Hi**	ON	OFF	1100	
High	OFF	OFF	1400	





# Performance Data

## 2/4TEE3F39 AIRFLOW PERFORMANCE TABLE

AIRFLOW PERFORMANCE 2/4TEE39A1 WITH WET COIL, FILTER, NO HEATER												
OUTDOOR UNIT SIZE (TONS)	Speed Settings	AIRFLOW SETTING	DIP SWITCH SETTING				Airflow Power	EXTERNAL STATIC PRESSURE				
			SW 1	SW 2	SW 3	SW 4		0.1	0.3	0.5	0.7	0.9
2 tons	Low	350 CFM/ton	ON	ON	OFF	ON	CFM Watts	762 69	739 107	723 153	679 191	636 231
	Normal	400 CFM/ton	ON	ON	OFF	OFF	CFM Watts	840 84	840 126	832 176	787 228	742 265
	High	450 CFM/ton	ON	ON	ON	OFF	CFM Watts	935 105	931 151	921 202	904 255	869 317
2.5 tons	Low	350 CFM/ton	OFF	ON	OFF	ON	CFM Watts	903 99	910 145	897 194	873 249	839 301
	Normal	400 CFM/ton	OFF	ON	OFF	OFF	CFM Watts	1029 129	1029 178	1031 236	1013 294	986 353
	High	450 CFM/ton	OFF	ON	ON	OFF	CFM Watts	1139 165	1164 226	1167 288	1150 350	1131 409
3 tons	Low	350 CFM/ton	ON	OFF	OFF	ON	CFM Watts	1062 137	1074 195	1083 256	1072 316	1046 375
	Normal	400 CFM/ton	ON	OFF	OFF	OFF	CFM Watts	1224 201	1248 265	1237 318	1208 383	1196 441
	High	450 CFM/ton	ON	OFF	ON	OFF	CFM Watts	1380 270	1377 333	1363 398	1355 474	1368 561
3.5 tons	Low	350 CFM/ton	OFF	OFF	OFF	ON	CFM Watts	1243 201	1260 270	1248 336	1222 394	1216 459
	Normal **	400 CFM/ton	OFF	OFF	OFF	OFF	CFM Watts	1421 293	1413 357	1416 434	1419 519	1375 577
	High	450 CFM/ton	OFF	OFF	ON	OFF	CFM Watts	1596 409	1592 493	1533 536	1446 546	1373 579

NOTES:  
 1. \*\* Factory Setting  
 2. At continuous fan setting: Airflow values are approximately 50% of the listed values.

Airflow Performance with Auxiliary Heat			
Airflow Settings	Dip Switch Settings		Nominal Airflow
	Switch 7	Switch 8	
Low	ON	ON	600
Med -Lo	OFF	ON	900
Med-Hi**	ON	OFF	1100
High	OFF	OFF	1400

See Following Tables for heater application:  
 -Pressure Drop for Electric Heaters  
 -Minimum Heating Airflow Heater Matrix (on unit nameplates)



# Performance Data

## 2/4TEE3F40 AIRFLOW PERFORMANCE TABLE

AIRFLOW PERFORMANCE 2TEE3F40A, 4TEE3F40B WITH WET COIL, FILTER, NO HEATER													
OUTDOOR UNIT SIZE (TONS)	Speed Settings	AIRFLOW SETTING	DIP SWITCH SETTING				Airflow Power	EXTERNAL STATIC PRESSURE					
			SW 1	SW 2	SW 3	SW 4		0.1	0.2	0.3	0.5	0.7	0.9
2	Low	350 CFM/ton	ON	ON	OFF	ON	CFM Watts	745 90	725 105	700 120	620 150	595 185	555 225
	Normal	400 CFM/ton	ON	ON	OFF	OFF	CFM Watts	825 105	810 120	790 140	750 190	710 215	675 250
	High	450 CFM/ton	ON	ON	ON	OFF	CFM Watts	910 135	910 150	910 166	875 205	845 275	770 305
2.5	Low	350 CFM/ton	OFF	ON	OFF	ON	CFM Watts	870 125	865 140	855 160	820 205	805 255	750 280
	Normal	400 CFM/ton	OFF	ON	OFF	OFF	CFM Watts	1000 165	1000 185	1000 205	980 245	940 290	890 340
	High	450 CFM/ton	OFF	ON	ON	OFF	CFM Watts	1130 210	1125 235	1115 255	1100 305	1080 350	1055 400
3	Low	350 CFM/ton	ON	OFF	OFF	ON	CFM Watts	1075 185	1070 200	1060 220	1025 275	985 315	945 365
	Normal	400 CFM/ton	ON	OFF	OFF	OFF	CFM Watts	1200 235	1200 260	1195 290	1185 355	1170 440	1145 475
	High	450 CFM/ton	ON	OFF	ON	OFF	CFM Watts	1350 300	1365 345	1375 380	1375 440	1350 495	1320 550
3.5	Low	350 CFM/ton	OFF	OFF	OFF	ON	CFM Watts	1215 245	1215 270	1210 300	1205 355	1190 405	1160 460
	Normal **	400 CFM/ton	OFF	OFF	OFF	OFF	CFM Watts	1400 345	1400 395	1400 435	1400 485	1400 530	1400 575
	High	450 CFM/ton	OFF	OFF	ON	OFF	CFM Watts	1415 355	1425 390	1430 435	1425 495	1405 545	1365 595

NOTES:  
 1. \*\* Factory Setting  
 2. At continuous fan setting: Airflow values are approximately 50% of the listed values.

2TEE3F40A / 4TEE3F31B Airflow Performance with Auxiliary Heat				
Airflow Settings	Dip Switch Settings		Nominal Airflow	See Following Tables for heater application: -Pressure Drop for Electric Heaters -Minimum Heating Airflow Heater Matrix (on unit nameplates)
	Switch 7	Switch 8		
Low	ON	ON	600	
Med -Lo	OFF	ON	900	
Med-Hi**	ON	OFF	1100	
High	OFF	OFF	1400	



# Performance Data

## 2/4TEE3F48 AIRFLOW PERFORMANCE TABLE

AIRFLOW PERFORMANCE 2/4TEE48A1 WITH WET COIL, FILTER, NO HEATER												
OUTDOOR UNIT SIZE (TONS)	Speed Settings	AIRFLOW SETTING	DIP SWITCH SETTING				Airflow Power	EXTERNAL STATIC PRESSURE				
			SW 1	SW 2	SW 3	SW 4		0.1	0.3	0.5	0.7	0.9
3 tons	Low	350 CFM/ton	ON	ON	OFF	ON	CFM Watts	1096 162	1117 219	1129 278	1139 339	1146 405
	Normal	400 CFM/ton	ON	ON	OFF	OFF	CFM Watts	1253 224	1291 297	1311 366	1320 437	1316 496
	High	450 CFM/ton	ON	ON	ON	OFF	CFM Watts	1435 312	1465 394	1471 463	1447 516	1487 611
3.5 tons	Low	350 CFM/ton	OFF	ON	OFF	ON	CFM Watts	1277 233	1313 308	1332 381	1345 447	1325 513
	Normal	400 CFM/ton	OFF	ON	OFF	OFF	CFM Watts	1482 342	1512 423	1517 496	1500 559	1533 648
	High	450 CFM/ton	OFF	ON	ON	OFF	CFM Watts	1661 462	1671 541	1690 632	1694 713	1623 727
4 tons	Low	350 CFM/ton	ON	OFF	OFF	ON	CFM Watts	1478 336	1506 421	1510 495	1493 552	1519 645
	Normal	400 CFM/ton	ON	OFF	OFF	OFF	CFM Watts	1678 470	1691 554	1711 647	1719 728	1642 744
	High	450 CFM/ton	ON	OFF	ON	OFF	CFM Watts	1870 653	1907 770	1896 838	1798 828	1739 812
5 tons	Low	350 CFM/ton	OFF	OFF	OFF	ON	CFM Watts	1628 444	1641 525	1660 612	1673 696	1641 748
	Normal **	400 CFM/ton	OFF	OFF	OFF	OFF	CFM Watts	1884 652	1915 775	1896 846	1796 821	1724 830
	High	450 CFM/ton	OFF	OFF	ON	OFF	CFM Watts	1878 653	1911 775	1897 845	1799 822	1718 823

NOTES:  
 1. \*\* Factory Setting  
 2. At continuous fan setting: Airflow values are approximately 50% of the listed values

Airflow Performance with Auxiliary Heat			
Airflow Settings	Dip Switch Settings		Nominal Airflow
	Switch 7	Switch 8	
Low	ON	ON	800
Med -Lo	OFF	ON	1100
Med-Hi**	ON	OFF	1400
High	OFF	OFF	1700

See Following Tables for heater application:  
 -Pressure Drop for Electric Heaters  
 -Minimum Heating Airflow Heater Matrix (on unit nameplates)



**TRANE®**

# Performance Data

**2/4TEE3F49 AIRFLOW PERFORMANCE TABLE**

AIRFLOW PERFORMANCE 2TEE3F49A, 4TEE3F49B WITH WET COIL, FILTER, NO HEATER													
OUTDOOR UNIT SIZE (TONS)	Speed Settings	AIRFLOW SETTING	DIP SWITCH SETTING				Airflow Power	EXTERNAL STATIC PRESSURE					
			SW 1	SW 2	SW 3	SW 4		0.1	.02	0.3	0.5	0.7	0.9
3	Low	350 CFM/ton	ON	ON	OFF	ON	CFM Watts	1050 168	1045 192	1040 217	1025 265	1005 313	1000 362
	Normal	400 CFM/ton	ON	ON	OFF	OFF	CFM Watts	1190 215	1195 245	1200 274	1200 333	1185 392	1175 451
	High	450 CFM/ton	ON	ON	ON	OFF	CFM Watts	1355 295	1360 326	1370 358	1365 421	1345 484	1325 547
3.5	Low	350 CFM/ton	OFF	ON	OFF	ON	CFM Watts	1200 234	1205 264	1215 294	1210 354	1205 413	1185 473
	Normal	400 CFM/ton	OFF	ON	OFF	OFF	CFM Watts	1405 326	1405 366	1405 402	1395 462	1390 505	1290 532
	High	450 CFM/ton	OFF	ON	ON	OFF	CFM Watts	1580 429	1570 458	1560 496	1555 573	1550 608	1390 547
4	Low	350 CFM/ton	ON	OFF	OFF	ON	CFM Watts	1405 326	1405 366	1405 402	1395 462	1390 505	1290 532
	Normal	400 CFM/ton	ON	OFF	OFF	OFF	CFM Watts	1600 444	1595 475	1585 515	1590 593	1555 623	1390 547
	High	450 CFM/ton	ON	OFF	ON	OFF	CFM Watts	1775 635	1780 679	1785 701	1740 697	1600 656	1450 611
5	Low	350 CFM/ton	OFF	OFF	OFF	ON	CFM Watts	1565 427	1560 458	1550 497	1545 577	1540 609	1380 539
	Normal **	400 CFM/ton	OFF	OFF	OFF	OFF	CFM Watts	1800 652	1800 693	1800 714	1740 703	1600 651	1450 621
	High	450 CFM/ton	OFF	OFF	ON	OFF	CFM Watts	2020 808	1975 801	1930 790	1795 760	1665 715	1530 658

**NOTES:**

- \*\* Factory Setting
- At continuous fan setting: Airflow values are approximately 50% of the listed values.

2TEE3F49A / 4TEE3F49B Airflow Performance with Auxiliary Heat				
Airflow Settings	Dip Switch Settings		Nominal Airflow	See Following Tables for heater application: -Pressure Drop for Electric Heaters -Minimum Heating Airflow Heater Matrix (on unit nameplates)
	Switch 7	Switch 8		
Low	ON	ON	800	
Med -Lo	OFF	ON	1100	
Med-Hi**	ON	OFF	1400	
High	OFF	OFF	1700	



# Performance Data

## 2/4TEE3F64 AIRFLOW PERFORMANCE TABLE

AIRFLOW PERFORMANCE 2/4TEE64A1 WITH WET COIL, FILTER, NO HEATER												
OUTDOOR UNIT SIZE (TONS)	Speed Settings	AIRFLOW SETTING	DIP SWITCH SETTING				Airflow Power	EXTERNAL STATIC PRESSURE				
			SW 1	SW 2	SW 3	SW 4		0.1	0.3	0.5	0.7	0.9
3 tons	Low	350 CFM/ton	ON	ON	OFF	ON	CFM Watts	1192 191	1222 256	1226 315	1213 370	1185 420
	Normal	400 CFM/ton	ON	ON	OFF	OFF	CFM Watts	1380 269	1382 329	1388 396	1402 472	1381 531
	High	450 CFM/ton	ON	ON	ON	OFF	CFM Watts	1532 348	1564 433	1580 513	1583 590	1591 679
3.5 tons	Low	350 CFM/ton	OFF	ON	OFF	ON	CFM Watts	1389 272	1385 332	1396 400	1409 473	1387 532
	Normal	400 CFM/ton	OFF	ON	OFF	OFF	CFM Watts	1605 394	1630 482	1643 564	1636 633	1636 712
	High	450 CFM/ton	OFF	ON	ON	OFF	CFM Watts	1831 563	1846 651	1845 731	1793 769	1619 692
4 tons	Low	350 CFM/ton	ON	OFF	OFF	ON	CFM Watts	1588 385	1624 477	1632 555	1626 626	1627 701
	Normal	400 CFM/ton	ON	OFF	OFF	OFF	CFM Watts	1862 591	1879 685	1869 754	1783 762	1622 698
	High	450 CFM/ton	ON	OFF	ON	OFF	CFM Watts	2081 811	2052 863	1956 845	1827 806	1699 764
5 tons	Low	350 CFM/ton	OFF	OFF	OFF	ON	CFM Watts	2002 729	2005 816	1948 841	1806 787	1718 786
	Normal **	400 CFM/ton	OFF	OFF	OFF	OFF	CFM Watts	2225 978	2116 945	2010 913	1904 879	1765 841
	High	450 CFM/ton	OFF	OFF	ON	OFF	CFM Watts	2281 1061	2180 1025	2074 985	1956 941	1838 901

NOTES:  
 1. \*\* Factory Setting  
 2. At continuous fan setting: Airflow values are approximately 50% of the listed values

Airflow Performance with Auxiliary Heat			
Airflow Settings	Dip Switch Settings		Nominal Airflow
	Switch 7	Switch 8	
Low	ON	ON	900
Med -Lo	OFF	ON	1200
Med-Hi	ON	OFF	1500
High	OFF	OFF	1800

See Following Tables for heater application:  
 -Pressure Drop for Electric Heaters  
 -Minimum Heating Airflow Heater Matrix (on unit nameplates)



**TRANE®**

# Performance Data

## 4TEE3F65 AIRFLOW PERFORMANCE TABLE

AIRFLOW PERFORMANCE 2TEE3F65A, 4TEE3F65B WITH WET COIL, FILTER, NO HEATER													
OUTDOOR UNIT SIZE (TONS)	Speed Settings	AIRFLOW SETTING	DIP SWITCH SETTING				Airflow Power	EXTERNAL STATIC PRESSURE					
			SW 1	SW 2	SW 3	SW 4		0.1	0.2	0.3	0.5	0.7	0.9
3.0	Low	350 CFM/ton	ON	ON	OFF	ON	CFM Watts	1030 135	1030 160	1030 185	1015 235	1000 285	975 325
	Normal	400 CFM/ton	ON	ON	OFF	OFF	CFM Watts	1170 195	1170 225	1170 255	1170 315	1170 375	1170 435
	High	450 CFM/ton	ON	ON	ON	OFF	CFM Watts	1320 255	1325 295	1340 330	1370 405	1375 480	1365 545
3.5	Low	350 CFM/ton	OFF	ON	OFF	ON	CFM Watts	1195 210	1195 240	1195 320	1195 340	1195 385	1195 440
	Normal	400 CFM/ton	OFF	ON	OFF	OFF	CFM Watts	1380 290	1405 345	1425 390	1440 450	1440 515	1425 580
	High	450 CFM/ton	OFF	ON	ON	OFF	CFM Watts	1620 420	1620 455	1630 495	1645 565	1625 636	1590 695
4.0	Low	350 CFM/ton	ON	OFF	OFF	ON	CFM Watts	1365 265	1385 315	1405 365	1430 450	1450 505	1440 575
	Normal	400 CFM/ton	ON	OFF	OFF	OFF	CFM Watts	1630 435	1640 470	1650 505	1650 575	1640 640	1620 700
	High	450 CFM/ton	ON	OFF	ON	OFF	CFM Watts	1860 570	1860 620	1860 680	1860 785	1850 825	1710 830
5.0	Low	350 CFM/ton	OFF	OFF	OFF	ON	CFM Watts	1830 530	1810 565	1810 605	1830 730	1795 790	1740 805
	Normal **	400 CFM/ton	OFF	OFF	OFF	OFF	CFM Watts	2080 800	2075 855	2065 895	2010 925	1890 905	1750 870
	High	450 CFM/ton	OFF	OFF	ON	OFF	CFM Watts	2275 1015	2225 1005	2170 995	2035 955	1880 900	1750 840

NOTES:  
 1. \*\* Factory Setting  
 2. At continuous fan setting: Airflow values are approximately 50% of the listed values.

2TEE3F65A / 4TEE3F65B Airflow Performance with Auxiliary Heat				
Airflow Settings	Dip Switch Settings		Nominal Airflow	See Following Tables for heater application: -Pressure Drop for Electric Heaters -Minimum Heating Airflow Heater Matrix (on unit nameplates)
	Switch 7	Switch 8		
Low	ON	ON	900	
Med -Lo	OFF	ON	1200	
Med-Hi**	ON	OFF	1500	
High	OFF	OFF	1800	



# Performance Data

2/4TEE3F31 WIRING DATA (Indoor Blower Motor Powered from Heater Circuit 1)											
Heater Model No.	Number of Circuits/Phase	240 VOLT					208 VOLT				
		Capacity		Heater Amps per Circuit	Minimum Circuit Ampacity	Maximum Overload Protection	Capacity		Heater Amps per Circuit	Minimum Circuit Ampacity	Maximum Overload Protection
		KW	BTUH				KW	BTUH			
No Heater	-	-	-	-	5	15	-	-	-	5	15
BAYHTR1405 +++	1/1	4.80	16400	20	30	30	3.60	12300	17.3	27	30
BAYHTR1408 +++	1/1	7.68	26200	32	45	45	5.76	19700	27.7	40	40
BAYHTR1410 +++	1/1	9.60	32800	40	55	60	7.20	24600	34.6	49	50
BAYHTR3410 000	1/3	9.60	32800	34.6	43	45	7.20	24600	30	37	40
BAYHTR1415 BRK	2/1	15.36	52400	40/24	55*/30	60*/30	11.53	39300	34.6/20.8	49*/26	50*/30
BAYHTR3415 000	1/3	15.36	52400	38.2	52	60	11.53	39300	33.1	46	50
BAYHTR1419 BRK	2/1	19.2	65500	32/48	45*/60	45*/60	14.42	49200	27.7/41.6	40*/52	40*/60

NOTES:  
 \* Circuit 1/Circuit 2 (Minimum Circuit Ampacity for Circuit 1 includes Blower Motor Amps)  
 +++ = 000, BRK, PDC 000 = pigtails, BRK = contains circuit breakers, PDC = contains pull disconnect  
 IMPORTANT: Any power supply and/or combination power supply, circuit or circuits must be wired and protected in accordance with local Electrical Codes.

2/4TEE3F37 WIRING DATA (Indoor Blower Motor Powered from Heater Circuit 1)											
Heater Model No.	Number of Circuits/Phase	240 VOLT					208 VOLT				
		Capacity		Heater Amps per Circuit	Minimum Circuit Ampacity	Maximum Overload Protection	Capacity		Heater Amps per Circuit	Minimum Circuit Ampacity	Maximum Overload Protection
		KW	BTUH				KW	BTUH			
No Heater	-	-	-	-	5	15	-	-	-	5	15
BAYHTR1405 +++	1/1	4.80	16400	20	30	30	3.60	12300	17.3	27	30
BAYHTR1408 +++	1/1	7.68	26200	32	45	45	5.76	19700	27.7	40	40
BAYHTR1410 +++	1/1	9.60	32800	40	55	60	7.20	24600	34.6	49	50
BAYHTR3410 000	1/3	9.60	32800	34.6	43	45	7.20	24600	30	37	40
BAYHTR1415 BRK	2/1	15.36	52400	40/24	55*/30	60*/30	11.53	39300	34.6/20.8	49*/26	50*/30
BAYHTR3415 000	1/3	15.36	52400	38.2	52	60	11.53	39300	33.1	46	50
BAYHTR1419 BRK	2/1	19.2	65500	32/48	45*/60	45*/60	14.42	49200	27.7/41.6	40*/52	40*/60

NOTES:  
 \* Circuit 1/Circuit 2 (Minimum Circuit Ampacity for Circuit 1 includes Blower Motor Amps)  
 +++ = 000, BRK, PDC 000 = pigtails, BRK = contains circuit breakers, PDC = contains pull disconnect  
 IMPORTANT: Any power supply and/or combination power supply, circuit or circuits must be wired and protected in accordance with local Electrical Codes.

2/4TEE39A1000A WIRING DATA (Indoor Blower Motor Powered from Heater Circuit *)											
Heater Model No.	Number of Circuits/Phase	240 VOLT					208 VOLT				
		Capacity		Heater Amps per Circuit	Minimum Circuit Ampacity	Maximum Overload Protection	Capacity		Heater Amps per Circuit	Minimum Circuit Ampacity	Maximum Overload Protection
		KW	BTUH				KW	BTUH			
No Heater	-	-	-	-	5	15	-	-	-	5	15
BAYHTR1405 +++	1/1	4.80	16400	20	30	30	3.60	12300	17.3	27	30
BAYHTR1408 +++	1/1	7.68	26200	32	45	45	5.76	19700	27.7	40	40
BAYHTR1410 +++	1/1	9.60	32800	40	55	60	7.20	24600	34.6	49	50
BAYHTR3410 000	1/3	9.60	32800	34.6	43	45	7.20	24600	30	37	40
BAYHTR1415 BRK	2/1	15.36	52400	40/24	55*/30	60*/30	11.52	39300	34.6/20.8	49*/26	50*/30
BAYHTR3415 000	1/3	15.36	52400	38.2	52	60	11.52	39300	33.1	46	50
BAYHTR1419 BRK	2/1	19.20	65500	32/48	45*/60	45*/60	14.42	49200	27.7/41.6	40*/52	40*/60

NOTES:  
 \* Circuit 1/Circuit 2 (Minimum Circuit Ampacity for Circuit 1 includes Blower Motor Amps)  
 +++ = 000, BRK, PDC 000 = pigtails, BRK = contains circuit breakers, PDC = contains pull disconnect  
 IMPORTANT: Any power supply and/or combination power supply, circuit or circuits must be wired and protected in accordance with local Electrical Codes.

- Notes:
- See Product Data or Air Handler Nameplate for approved combinations of Air Handlers and Heaters.
  - Heater model number may have additional suffix digits.



**TRANE®**

# Performance Data

2/4TEE3F40 WIRING DATA (Indoor Blower Motor Powered from Heater Circuit *)											
Heater Model No.	Number of Circuits/Phase	240 VOLT					208 VOLT				
		Capacity		Heater Amps per Circuit	Minimum Circuit Ampacity	Maximum Overload Protection	Capacity		Heater Amps per Circuit	Minimum Circuit Ampacity	Maximum Overload Protection
		KW	BTUH				KW	BTUH			
No Heater	-	-	-	-	5	15	-	-	-	5	15
BAYHTR1405 +++	1/1	4.80	16400	20	30	30	3.60	12300	17.3	27	30
BAYHTR1408 +++	1/1	7.68	26200	32	45	45	5.76	19700	27.7	40	40
BAYHTR1410 +++	1/1	9.60	32800	40	55	60	7.20	24600	34.6	49	50
BAYHTR3410 000	1/3	9.60	32800	34.6	43	45	7.20	24600	30	37	40
BAYHTR1415 BRK	2/1	15.36	52400	40/24	55*/30	60*/30	11.52	39300	34.6/20.8	49*/26	50*/30
BAYHTR3415 000	1/3	15.36	52400	38.2	52	60	11.52	39300	33.1	46	50
BAYHTR1419 BRK	2/1	19.2	65500	32/48	45*/60	45*/60	14.42	49200	27.7/41.6	40*/52	40*/60
BAYHTR1425 BRK	3/1	24.96	85200	44/40/20	55/55*/25	60/60*/25	18.73	63900	38.1/34.6/17.3	48/49*/22	50*/50/25

NOTES:

\* Circuit 1/Circuit 2 (Minimum Circuit Ampacity for Circuit 1 includes Blower Motor Amps)

+++ = 000, BRK, PDC 000 = pigtailed, BRK = contains circuit breakers, PDC = contains pull disconnect

IMPORTANT: Any power supply and/or combination power supply, circuit or circuits must be wired and protected in accordance with local Electrical Codes.

2/4TEE3F48A1000A WIRING DATA CHECK DATA (Indoor Blower Motor Powered from Heater Circuit *)											
Heater Model No.	Number of Circuits/Phase	240 VOLT					208 VOLT				
		Capacity		Heater Amps per Circuit	Minimum Circuit Ampacity	Maximum Overload Protection	Capacity		Heater Amps per Circuit	Minimum Circuit Ampacity	Maximum Overload Protection
		KW	BTUH				KW	BTUH			
No Heater	-	-	-	-	9	15	-	-	-	9	15
BAYHTR1405 +++	1/1	4.80	16400	20	34	35	3.60	12300	17.3	30	30
BAYHTR1408 +++	1/1	7.68	26200	32	49	50	5.76	19700	27.7	43	45
BAYHTR1410 +++	1/1	9.60	32800	40	59	60	7.20	24600	34.6	52	60
BAYHTR3410 000	1/3	9.60	32800	34.6	43	45	7.20	24600	30	37	40
BAYHTR1415 BRK	2/1	15.36	52400	40/24	59*/30	60*/30	11.53	39300	34.6/20.8	52*/26	60*/30
BAYHTR3415 000	1/3	15.36	52400	38.2	55	60	11.53	39300	33.1	49	50
BAYHTR1419 BRK	2/1	19.20	65500	32/48	49*/60	50*/60	14.42	49200	27.7/41.6	43*/52	45*/60
BAYHTR1425 BRK	3/1	24.96	85200	44/40/20	55/59*/25	60/60*/25	18.73	63900	38.1/34.6/17.3	48/52*/22	50/60*/25

NOTES:

\* Circuit 1/Circuit 2 (Minimum Circuit Ampacity for Circuit 1 includes Blower Motor Amps)

+++ = 000, BRK, PDC 000 = pigtailed, BRK = contains circuit breakers, PDC = contains pull disconnect

IMPORTANT: Any power supply and/or combination power supply, circuit or circuits must be wired and protected in accordance with local Electrical Codes.

2/4TEE3F49 WIRING DATA CHECK DATA (Indoor Blower Motor Powered from Heater Circuit *)											
Heater Model No.	Number of Circuits/Phase	240 VOLT					208 VOLT				
		Capacity		Heater Amps per Circuit	Minimum Circuit Ampacity	Maximum Overload Protection	Capacity		Heater Amps per Circuit	Minimum Circuit Ampacity	Maximum Overload Protection
		KW	BTUH				KW	BTUH			
No Heater	-	-	-	-	9	15	-	-	-	9	15
BAYHTR1405 +++	1/1	4.80	16400	20	34	40	3.60	12300	17.3	30	30
BAYHTR1408 +++	1/1	7.68	26200	32	49	50	5.76	19700	27.7	43	45
BAYHTR1410 +++	1/1	9.60	32800	40	59	60	7.20	24600	34.6	52	60
BAYHTR3410 000	1/3	9.60	32800	34.6	43	45	7.20	24600	30	37	40
BAYHTR1415 BRK	2/1	15.36	52400	40/24	59*/30	60*/30	11.53	39300	34.6/20.8	52*/26	60*/30
BAYHTR3415 000	1/3	15.36	52400	38.2	55	60	11.53	39300	33.1	49	50
BAYHTR1419 BRK	2/1	19.2	65500	32/48	49*/60	50*/60	14.42	49200	27.7/41.6	43*/52	45*/60
BAYHTR1425 BRK	3/1	24.96	85200	44/40/20	55/59*/25	60/60*/25	18.73	63900	38.1/34.6/17.3	48/50*/22	50/60*/25

NOTES:

\* Circuit 1/Circuit 2 (Minimum Circuit Ampacity for Circuit 1 includes Blower Motor Amps)

+++ = 000, BRK, PDC 000 = pigtailed, BRK = contains circuit breakers, PDC = contains pull disconnect

IMPORTANT: Any power supply and/or combination power supply, circuit or circuits must be wired and protected in accordance with local Electrical Codes.

Notes:

1. See Product Data or Air Handler Nameplate for approved combinations of Air Handlers and Heaters.

2. Heater model number may have additional suffix digits.





# Performance Data

2/4TEE3F64A1000A WIRING DATA (Indoor Blower Motor Powered from Heater Circuit *)											
Heater Model No.	Number of Circuits/Phase	240 VOLT					208 VOLT				
		Capacity		Heater Amps per Circuit 240	Minimum Circuit Ampacity 240	Maximum Overload Protection 240	Capacity		Heater Amps per Circuit	Minimum Circuit Ampacity	Maximum Overload Protection
		KW	BTUH				KW	BTUH			
No Heater	-	-	-	-	9	15	-	-	-	9	15
BAYHTR1405 +++	1/1	4.80	16400	20	34	35	3.60	12300	17.3	30	30
BAYHTR1408 +++	1/1	7.68	26200	32	49	50	5.77	19700	27.7	43	45
BAYHTR1410 +++	1/1	9.60	32800	40	59	60	7.20	24600	34.6	52	60
BAYHTR3410 000	1/3	9.60	32800	34.6	43	45	7.20	24600	30	37	40
BAYHTR1415 BRK	2/1	15.36	52400	40/24	59*/30	60*/30	11.53	39300	34.6/20.8	52*/26	60*/30
BAYHTR3415 000	1/3	15.36	52400	38.2	55	60	11.53	39300	33.1	49	50
BAYHTR1419 BRK	2/1	19.2	65500	32/48	49*/60	50*/60	14.42	49200	27.7/41.6	43*/52	45*/60
BAYHTR1425 BRK	3/1	24.96	85200	44/40/20	55/59*/25	60/60*/25	18.73	63900	38.1/34.6/17.3	48/52*/22	50/60*/25

NOTES:  
 \* Circuit 1/Circuit 2 (Minimum Circuit Ampacity for Circuit 1 includes Blower Motor Amps)  
 +++ = 000, BRK, PDC 000 = pigtails, BRK = contains circuit breakers, PDC = contains pull disconnect  
 IMPORTANT: Any power supply and/or combination power supply, circuit or circuits must be wired and protected in accordance with local Electrical Codes.

2/4TEE3F65 WIRING DATA (Indoor Blower Motor Powered from Heater Circuit *)											
Heater Model No.	Number of Circuits/Phase	240 VOLT					208 VOLT				
		Capacity		Heater Amps per Circuit	Minimum Circuit Ampacity	Maximum Overload Protection	Capacity		Heater Amps per Circuit	Minimum Circuit Ampacity	Maximum Overload Protection
		KW	BTUH				KW	BTUH			
No Heater	-	-	-	-	9	15	-	-	-	9	15
BAYHTR1405 +++	1/1	4.80	16400	20	34	35	3.60	12300	17.3	30	30
BAYHTR1408 +++	1/1	7.68	26200	32	49	50	5.77	19700	27.7	43	45
BAYHTR1410 +++	1/1	9.60	32800	40	59	60	7.20	24600	34.7	52	60
BAYHTR3410 000	1/3	9.60	32800	34.6	43	45	7.20	24600	30	37	40
BAYHTR1415 BRK	2/1	15.36	52400	44/20	59*/30	60*/30	11.53	39300	38.2/17.3	52*/26	60*/30
BAYHTR3415 000	1/3	15.36	52400	38.2	55	60	11.53	39300	33	49	50
BAYHTR1419 BRK	2/1	19.2	65500	32/48	49*/60	50*/60	14.42	49200	27.7/41.6	43*/52	45*/60
BAYHTR1425 BRK	3/1	24.96	85200	44/40/20	55/59*/25	60/60*/25	18.73	63900	38.1/34.6/17.3	48/50*/22	50/60*/25

NOTES:  
 \* Circuit 1/Circuit 2 (Minimum Circuit Ampacity for Circuit 1 includes Blower Motor Amps)  
 +++ = 000, BRK, PDC 000 = pigtails, BRK = contains circuit breakers, PDC = contains pull disconnect  
 IMPORTANT: Any power supply and/or combination power supply, circuit or circuits must be wired and protected in accordance with local Electrical Codes.

- Notes:  
 1. See Product Data or Air Handler Nameplate for approved combinations of Air Handlers and Heaters.  
 2. Heater model number may have additional suffix digits.

## AIR HANDLER ELECTRIC HEATER PRESSURE DROP

AIR FLOW CFM	NUMBER OF RACKS					AIR FLOW CFM	NUMBER OF RACKS				
	1	2	3	4	5		1	2	3	4	5
	AIR PRESSURE DROP INCHES W.G.						AIR PRESSURE DROP INCHES W.G.				
600	0.01	0.02	0.02			1400	0.07	0.08	0.10	0.11	0.13
700	0.01	0.02	0.02			1500	0.08	0.09	0.11	0.13	0.15
800	0.02	0.03	0.03	0.04		1600	0.09	0.10	0.12	0.15	0.17
900	0.03	0.03	0.04	0.05		1700	0.10	0.11	0.14	0.17	0.19
1000	0.04	0.04	0.05	0.06		1800	0.11	0.13	0.16	0.19	0.21
1100	0.04	0.05	0.06	0.07	0.08	1900	0.13	0.15	0.18	0.21	0.23
1200	0.05	0.06	0.07	0.08	0.09	2000	0.14	0.17	0.20	0.23	0.26
1300	0.06	0.07	0.08	0.09	0.11						

HEATER RACKS	
HEATER MODEL NO.	NO. OF RACKS
BAYHTR1405	1
BAYHTR1408	2
BAYHTR1/3410	2
BAYHTR1/3415	3
BAYHTR1419	4
BAYHTR1425	5



# Performance Data

## 2/4TEE3F MINIMUM HEATING AIRFLOW CFM HEATER MATRIX

MINIMUM AIRFLOW WITH AUXILIARY HEAT		HEATER MODEL NUMBER BAYHTR----					
		1405 4.80kw	1408 7.68kw	1410 3410 9.60kw	1415 3415 15.36kw	1419 19.20kw	1425 24.96kw
MODEL NUMBER	APPLICATION						
NUMBER OF HEATER RACKS		1	2	2	3	4	5
2/4TEE3F31	A/C or Elec. Furnace	700	700	700	700	1000	N/A
	Heat Pump	1000	1000	1000	1125	1350	N/A
2/4TEE3F37	A/C or Elec. Furnace	600	600	600	1000	1000	N/A
	Heat Pump	700	900	900	1300	1350	N/A
2/4TEE3F39	A/C or Elec. Furnace	900	900	900	900	900	N/A
	Heat Pump	900	900	900	1400**	1400**	N/A
2/4TEE3F40	A/C or Elec. Furnace	600	600	600	1100	1100	1100
	Heat Pump	1100	1100	1100	1400	1400	1400
2/4TEE3F48	A/C or Elec. Furnace	800	800	800	800^	800^	800^^
	Heat Pump	800	800	800	800^	800^	800^^
2/4TEE3F49	A/C or Elec. Furnace	700	700	700	1400	1400	1400
	Heat Pump	1400	1400	1400	1600	1600	1600
2/4TEE3F64	A/C or Elec. Furnace	900	900	900	900@	900	900
	Heat Pump	900	900	900	900@	900	900
2/4TEE3F65	A/C or Elec. Furnace	900	900	900	1200	1200	1200
	Heat Pump	1500*	1500*	1500*	1800	1800	1800

\*For upflow position only, minimum setting is 1200  
 \*\* For horizontal right and downflow only, minimum setting is 1100CFM  
 ^ 208V approved for upflow and horizontal right only  
 ^^ Not qualified for downflow  
 @ Not approved for horizontal left

## AIR HANDLER SUBBASE

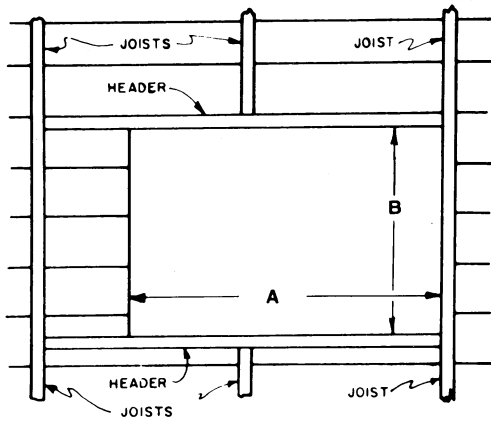

FIG. 2

FLOOR OPENING - SIZE		
MODEL NO.	A	B
TAYBASE100	23-3/4	14-13/16
TAYBASE101	21-3/4	14-13/16
TAYBASE102	26-3/4	14-13/16

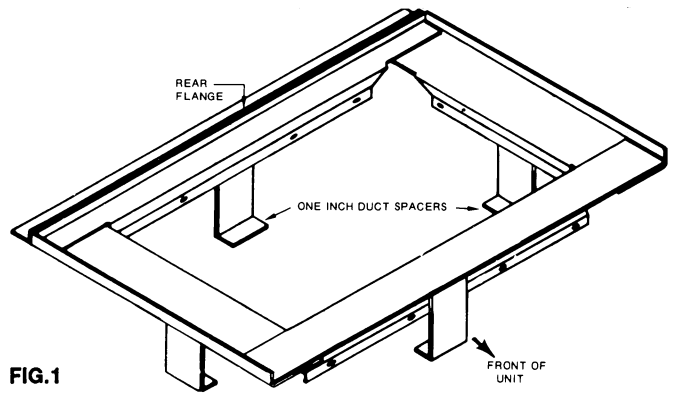

FIG. 1

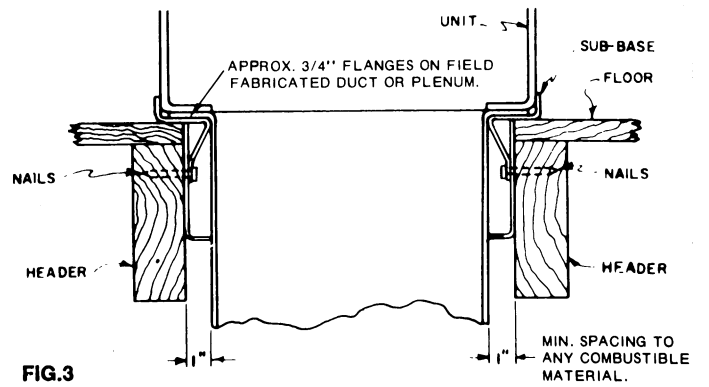

FIG. 3



**TRANE®**

# Electrical Data

## WIRING DIAGRAM FOR VARIABLE SPEED AIR HANDLERS

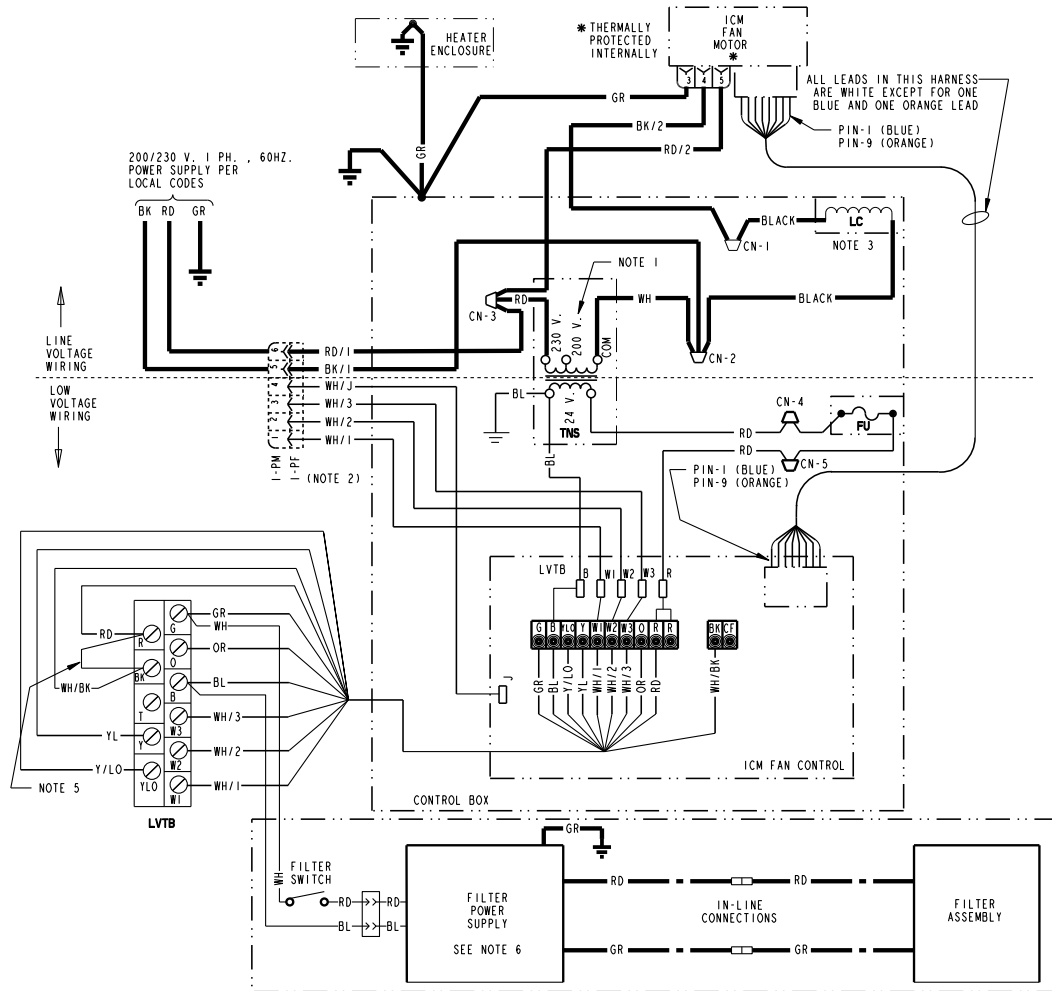

### NOTES:

- FOR 200V OPERATION SWAP RED TRANSFORMER LEAD AND INSULATED CAP ON 200V CENTER TRANSFORMER TERMINAL.
- WHEN HEATERS ARE USED, DISCARD I-PM WITH ATTACHED LEADS AND CONNECT I-PF TO THE MATING PLUG IN THE HEATER CONTROL BOX.
- LINE CHOKE MAY NOT BE USED ON ALL MODELS. BK/2 LEAD IN CN-2 IF CHOKE NOT USED.
- FOR COOLING SYSTEMS Y MUST BE CONNECTED TO THE LVTB, FOR HEAT PUMP SYSTEM Y AND O MUST BE CONNECTED TO THE LVTB. FOR TWO SPEED SYSTEMS, USE Y/LO FOR LOW SPEED AND Y FOR HIGH SPEED, CONNECT TO THE LVTB.
- IF OPTIONAL HUMIDISTAT IS USED, REMOVE R TO BK JUMPER ON TERMINAL BOARD AND INSTALL HUMIDISTAT BETWEEN R AND BK. JUMPER R TO O FOR COOLING-ONLY NON-HEAT PUMP SYSTEMS WITH A HUMIDISTAT.
- FILTER POWER SUPPLY WIRING MAY NOT BE USED ON ALL MODELS.
- FOR REPLACEMENT FUSE, USE LITTLEFUSE LMF 3-2/10 OR BUSSMAN GMD 3-2/10

MODEL
2TEE3D**
4TEE3D**
2TEE3F**
4TEE3F**

\*SIGNIFIES ALL DIGITS USED IN THIS SPACE

### LEGEND

— 24 V. WIRING	} FACTORY WIRING	POL. PLUG FEMALE HOUSING (MALE TERMINALS)
- - - 24 V. WIRING		
- - - 15 KV WIRING		
GROUND		
JUNCTION		
CAPACITOR		
WIRE NUT OR CONNECTOR		
TERMINAL		
TRANSFORMER		
FUSE		
TERMINAL BLOCK/BOARD		
RELAY CONTACT NO		
MAGNETIC COIL		

CN WIRE CONNECTOR  
FU FUSE  
ICM INTEGRAL CONTROL MOTOR  
LC LINE CHOKE  
LVTB LOW VOLTAGE TERMINAL BLOCK  
PF POLARIZED PLUG (FEMALE HOUSING)  
PM POLARIZED PLUG (MALE HOUSING)  
TNS TRANSFORMER

COLOR OF WIRE  
BK/BL BLACK WIRE WITH BLUE MARKER  
COLOR OF MARKER  
BK BLACK RD RED OR ORANGE  
BL BLUE WH WHITE GR GREEN  
BR BROWN YL YELLOW PR PURPLE

**CAUTION**

USE COPPER CONDUCTORS ONLY!  
UNIT TERMINALS ARE NOT DESIGNED TO ACCEPT OTHER TYPES OF CONDUCTORS.  
Failure to do so may cause damage to the equipment.

**WARNING**

HAZARDOUS VOLTAGE!  
DISCONNECT ALL ELECTRICAL POWER INCLUDING REMOTE DISCONNECTS BEFORE SERVICING.  
Failure to disconnect power before servicing can cause severe personal injury or death.

PRINTED FROM:  
D801995 P01 REV01

# Field Wiring

## 2/4TEE3F AIR HANDLERS WITH SINGLE SPEED COOLING

**NOTES:**

- POWER WIRING AND GROUNDING OF EQUIPMENT MUST COMPLY WITH LOCAL CODES.
- BE SURE POWER SUPPLY AGREES WITH EQUIPMENT NAMEPLATE.
- LOW VOLTAGE WIRING TO BE NO. 18 A.W.G. MINIMUM.
- USE COPPER CONDUCTORS ONLY.
- POLARIZED PLUG SECTION PM-A IS ATTACHED TO HEATER CONTROL BOX. SECTION I-PF IS FACTORY WIRED INTO AIR HANDLER.
- TERMINAL W2 WILL HAVE INTERNAL CONNECTIONS ONLY IF SECOND CONTACTOR IS USED BY THE HEATER FOR CONTROLLING POWER TO ELECTRIC HEATING ELEMENTS. IF SECOND (BH) CONTACTOR IS NOT USED, THEN FIELD CONNECTIONS TO W2 CAN BE OMITTED AS APPROPRIATE.
- CONNECTIONS TO "R", "BK", "O", AND "Y" MUST BE MADE AS SHOWN FOR PROPER OPERATION OF BLOWER WITH HUMIDISTAT IN COOLING.

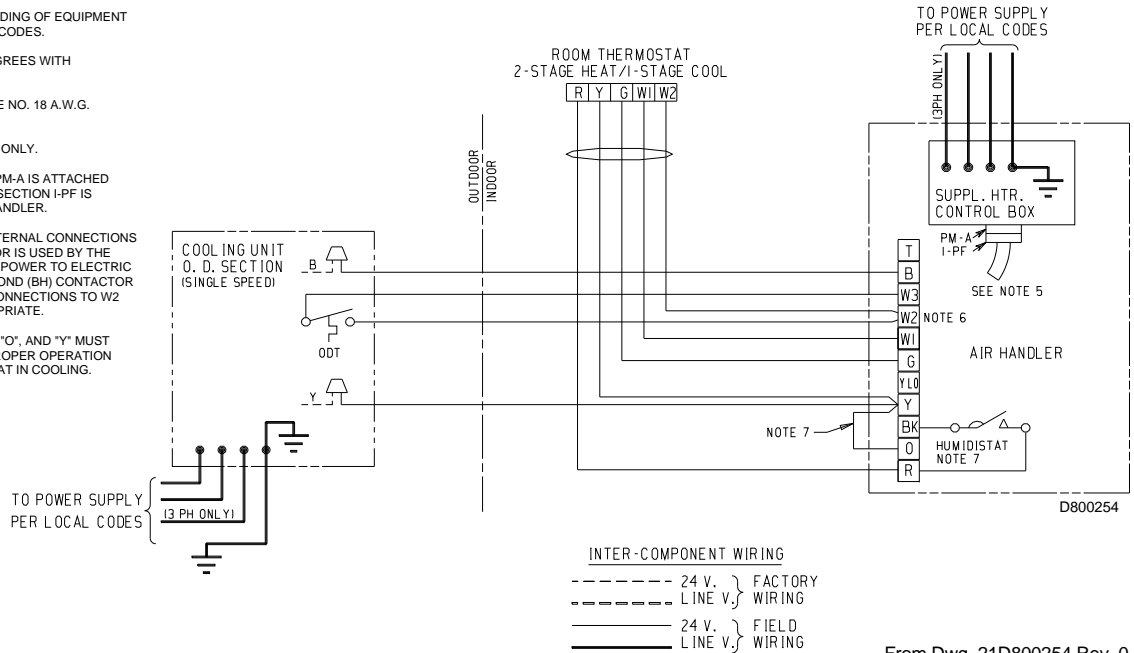

From Dwg. 21D800254 Rev. 0

## 2/4TEE3F AIR HANDLERS WITH SINGLE SPEED HEAT PUMP

**NOTES:**

- POWER WIRING AND GROUNDING OF EQUIPMENT MUST COMPLY WITH LOCAL CODES.
- BE SURE POWER SUPPLY AGREES WITH EQUIPMENT NAMEPLATE.
- LOW VOLTAGE WIRING TO BE NO. 18 A.W.G. MINIMUM.
- USE COPPER CONDUCTORS ONLY.
- POLARIZED PLUG SECTION PM-A IS ATTACHED TO HEATER CONTROL BOX. SECTION I-PF IS FACTORY WIRED INTO AIR HANDLER.
- TERMINAL W2 WILL HAVE INTERNAL CONNECTIONS ONLY IF SECOND CONTACTOR IS USED BY THE HEATER FOR CONTROLLING POWER TO ELECTRIC HEATING ELEMENTS. IF SECOND (BH) CONTACTOR IS NOT USED, THEN FIELD CONNECTIONS TO W2 CAN BE OMITTED AS APPROPRIATE.
- IF ODT IS NOT USED, THEN CONNECT APPROPRIATE JUMPER FROM W1 TO W2 ON LVTB.
- IF OPTIONAL HUMIDISTAT IS USED, REMOVE JUMPER (R-BK) AND INSTALL HUMIDISTAT BETWEEN "R" AND "BK".
- CONNECT IN THIS MANNER IF O. D. UNIT HAS "F" CONNECTION.
- CONNECT W3 TO W2 ONLY IF USING HEATER WITH 3 HEATER STAGES.

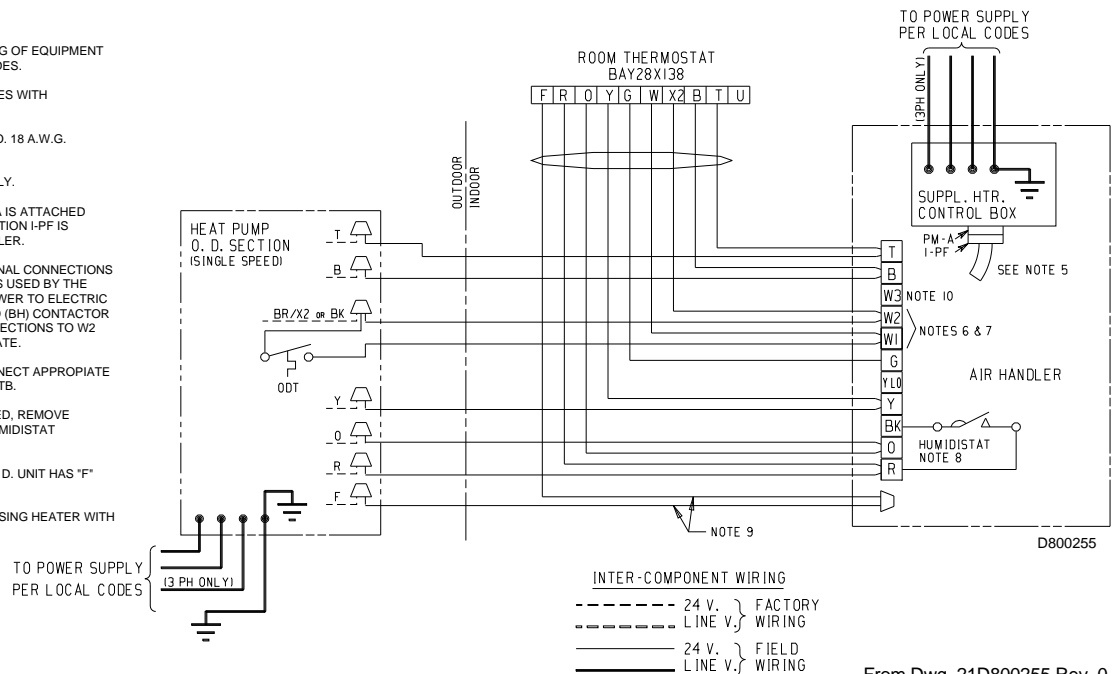

From Dwg. 21D800255 Rev. 0



**TRANE®**

# 2/4TEE3F31 Through 65 Convertibility

## SIX (6) WAY CONVERTIBILITY

### One Unit - 4 Applications (Conversions 1-4)

#### Horizontal Right (as shipped)

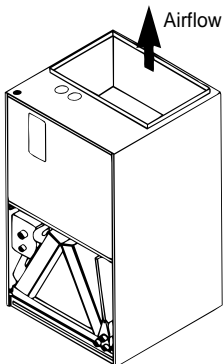
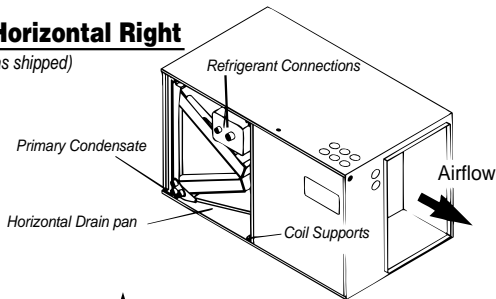

#### Vertical Upflow (as shipped) One-step Conversion Stand unit on end

#### Horizontal Left Rotate Coil

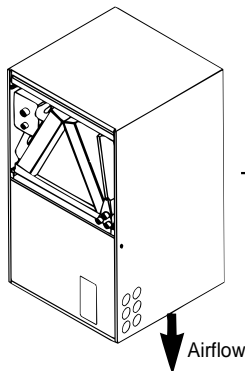
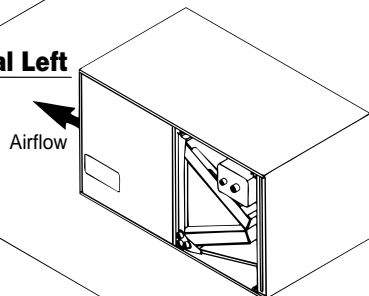

#### Vertical Downflow One-step Conversion from Horizontal left

### Easy Conversion to Opposite side Access (Conversions 5 & 6)

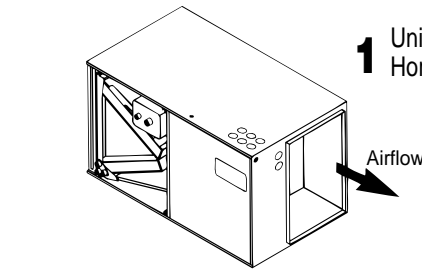

**1** Unit is shipped as Horizontal right

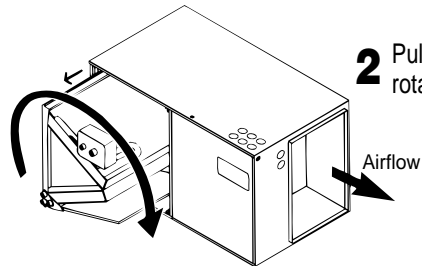

**2** Pull coil out and rotate the coil 180°

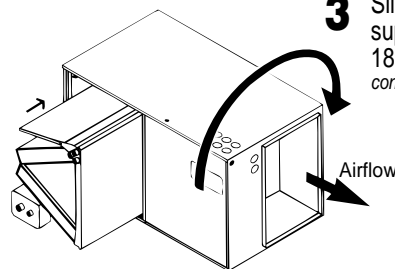

**3** Slide coil back in on supports and roll unit 180° (so primary condensate is down)

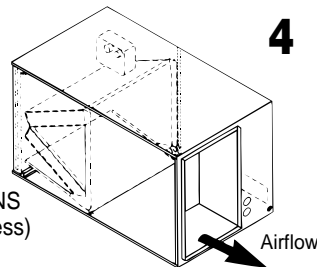

**4** Note connections and access are now on back side of unit

- 6 CONVERSION APPLICATIONS
1. Horizontal Right - (Front Access)
  2. Vertical Upflow
  3. Horizontal Left - (Front Access)
  4. Vertical Downflow
  5. Horizontal Right - (Rear Access)
  6. Horizontal Left - (Rear Access)

# Dimensions

## 2/4TEE3F AIR HANDLER DIMENSIONAL DATA

2/4TEE3F39, 2/4TEE3F48,  
2/4TEE3F64 and 2/4TEE3F65  
are two piece cabinets

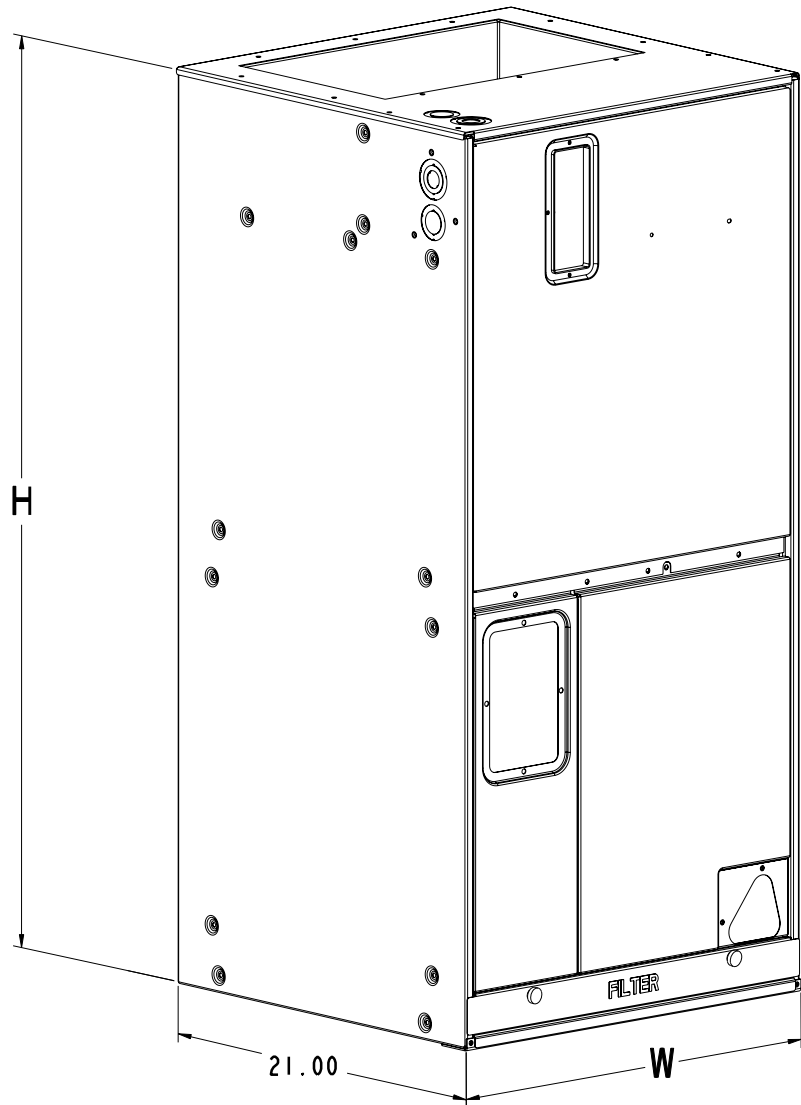

\* FOR TWO PIECE CABINET ONLY.

Model No.	H	W
2/4TEE3F31	43.00	21.50
2/4TEE3F37	45.00	23.50
2/4TEE3F39	57.90	23.50
2/4TEE3F40	51.75	26.00
2/4TEE3F48	57.90	23.50
2/4TEE3F49	57.90	26.00
2/4TEE3F62	62.75	26.00
2/4TEE3F64	57.90	23.50
2/4TEE3F65	62.75	26.00

From Dwg. B802150 Rev 1

# OUTLINE DRAWING FOR 2/4TEE3F31, 37, 40, 49, 65

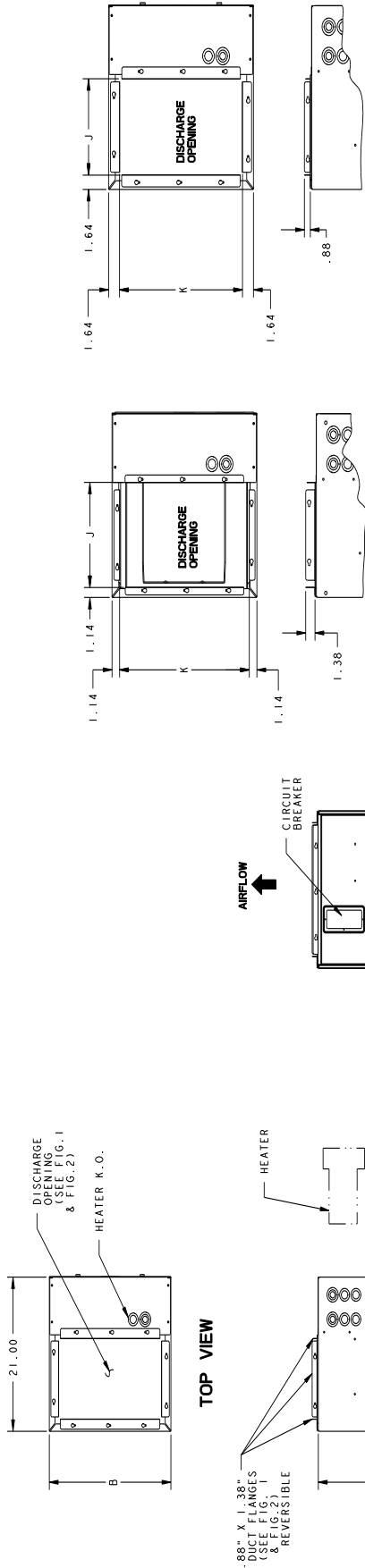

FIG. 1

FIG. 2

MODEL NO.	FIG. 1 J	FIG. 1 K	FIG. 2 J	FIG. 2 K
2TEEC3F18B, 4TEEC3F18B				
2TEEC3F188, 4TEEC3F188		19.22		18.22
2TEEC3F37A, 4TEEC3F37A				
2TEEC3F37A, 4TEEC3F37B	12.02	21.22	11.02	20.22
2TEEC3F42B, 4TEEC3F42B				
2TEEC3F42B, 4TEEC3F42B				
2TEEC3F49A, 4TEEC3F49A				
2TEEC3F49A, 4TEEC3F49B				
2TEEC3F55B, 4TEEC3F55B		23.72		22.72

## VERTICAL UPFLOW

MODEL NO.	A	B	C	D	E	F	G	FLOW CONTROL	GAS LINE BRASS	LIQ. LINE BRASS
2TEEC3F18B	43	21.50	19.50	15.57	3.62	1.89			3/8	1/4
2TEEC3F188									3/4	5/16
2TEEC3F37A	45	23.50	21.50	17.57	3.62	1.89	N/A		7/8	3/8
2TEEC3F37B									1-1/8	1/4
2TEEC3F42B	51.75	26	24	18.33	3.21	1.48			1/2	1/4
2TEEC3F42B	57.90	26	24	27.12	3.21	1.48	36.00	TXV/NB	5/8	5/16
2TEEC3F49A, 2TEEC3F55B	62.75	26	24	27.12	3.21	1.48			3/4	
4TEEC3F18B	43	21.50	19.50	15.57	3.62	1.89			7/8	3/8
4TEEC3F188									1-1/8	1/4
4TEEC3F37A	45	23.50	21.50	17.57	3.62	1.89	N/A		1-1/8	5/16
4TEEC3F37B									FCCV	3/4
4TEEC3F42B	51.75	26	24	18.33	3.21	1.48				
4TEEC3F42B	57.90	26	24	27.12	3.21	1.48	36.00	TXVB		
4TEEC3F49A, 4TEEC3F55B	62.75	26	24	27.12	3.21	1.48				
4TEEC3F49B, 4TEEC3F55B	57.90	23.50	21.50	30.47	3.62	1.89	31.15			
4TEEC3F48B, 4TEEC3F60B	57.90	23.50	21.50	30.47	3.62	1.89				
2TEEC3F48B, 2TEEC3F60B	51.75	24.32	21.50	15.57			N/A			
2TEEC3F48B, 2TEEC3F60B	51.75	24.32	21.50	15.57						
2TEEC3F48B, 2TEEC3F60B	43	21.50	19.50	15.57						

MINIMUM UNIT CLEARANCE TABLE		
	COMBUSTIBLE MATERIAL (REQUIRED)	SERVICE CLEARANCE (RECOMMENDED)
SIDES	0"	2"
FRONT	0"	21"
BACK	0"	0"
INLET DUCT	0"	1"
OUTLET DUCT	1"	1"

\* 1" FOR THE FIRST 3 FT. OF OUTLET DUCT WHEN ELECTRIC HEATERS ARE INSTALLED. CLEARANCE FOR 3 FT. OF PLENUM AND DUCT ARE APPROVED FOR 0" PLENUM AND DUCT CLEARANCE IN THE UPFLOW CONFIGURATION ONLY ON TWE-P MODELS.



# OUTLINE DRAWING FOR 2/4TEE3F39, 48, 64A1000A

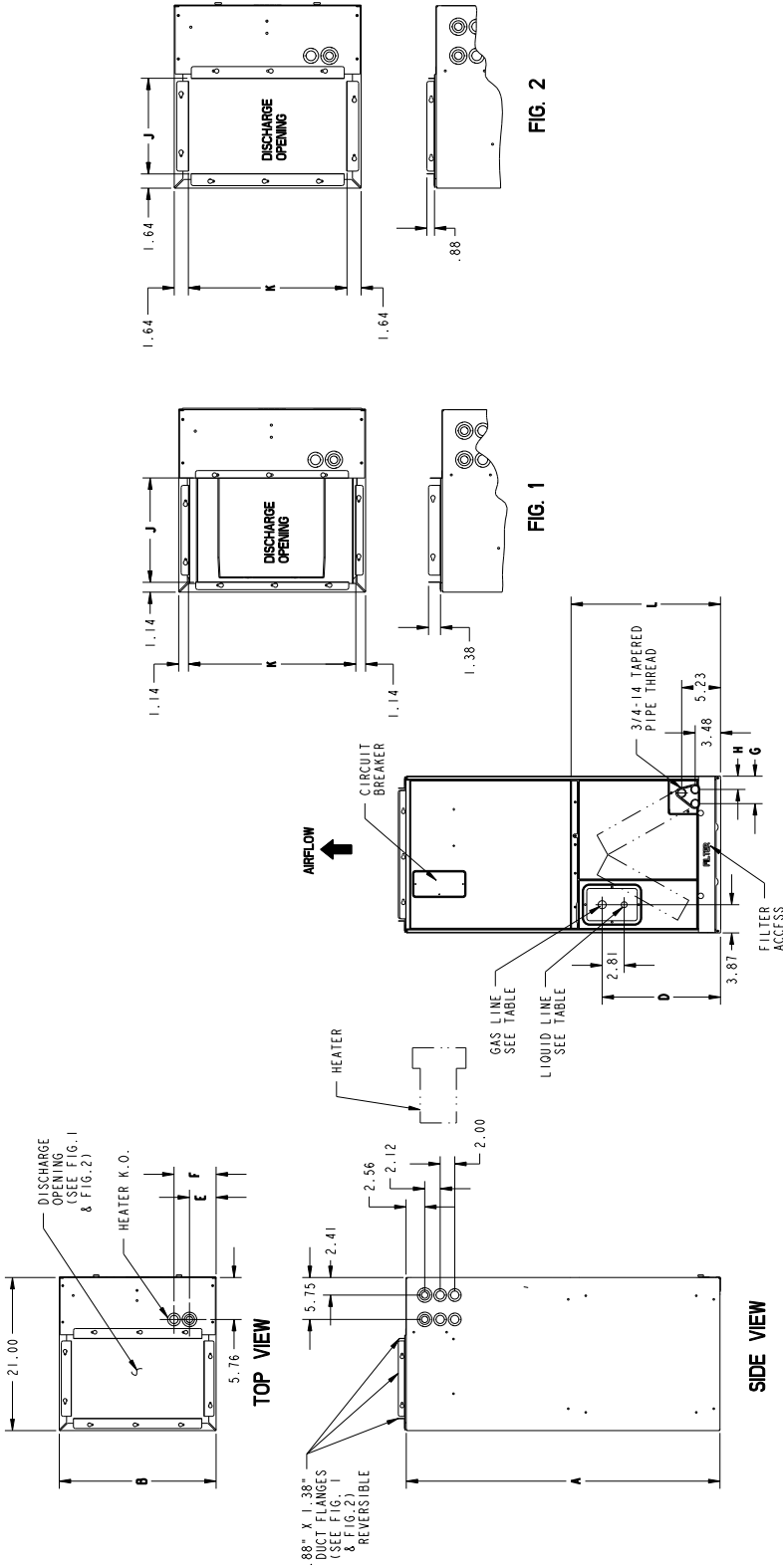

	TO COMBUSTIBLE MATERIAL (REQUIRED)	SERVICE CLEARANCE (RECOMMENDED)
SIDES	0"	2"
FRONT	0"	21"
BACK	0"	0"
INLET DUCT	0"	1"
OUTLET DUCT	1"	

\* 1" FOR THE FIRST 3 FT. OF OUTLET DUCT WHEN ELECTRIC HEATERS ARE INSTALLED EXCEPT MODELS BAYHRI405, 1408, AND 1410 ARE APPROVED FOR 0" PLENUM AND DUCT CLEARANCE IN THE UPFLOW CONFIGURATION ONLY ON TWE-P MODELS.

MODEL NO.	A	B	C	D	E	F	G	H	L	FLOW CONTROL	GAS LINE BRAZE	LIQ LINE BRAZE
2TEE3F39											7/8	
2TEE3F48											1-1/8	
2TEE3F64	57.9	23.5	21.5	17.57	4.65	6.77	3.62	1.89	31.15	TXV / NB	3/4	3/8
4TEE3F39											7/8	
4TEE3F48												
4TEE3F64												

# Mechanical Specification Options

---

## Features and General Information

These blower coil units are completely factory assembled including coil, condensate drain pan, fan, motor, filters and controls in an insulated casing that can be applied in horizontal or vertical configuration. The "Air-Tite™" model has 4.2 "R" value insulation and additional sealing systems. The 2/4TEE3F line of air handlers provides exclusive compact size combined with 6-way convertibility in sizes up to 5 ton.

The 3.5, 4, and 5 ton TEE3F models are available in 26" widths or with Vortica™ in 23.5" widths.

The unit ships in the vertical upflow configuration and converts to right-hand horizontal configuration just by laying the unit on its side. No tools required. Simple coil rotation provides downflow and horizontal left applications.

## Casing

These models have a rugged galvanized sheet metal and steel frame construction. The casing is painted with an enamel finish. The casing is insulated and provides knock-outs for electrical power and control wiring.

## Refrigerant Circuits

The 2/4TEE3F units have a single refrigerant circuit. The refrigerant circuit is controlled by a factory installed non-bleed thermal expansion valve (TXV).

## Coil

Aluminum fin surface is mechanically bonded to 3/8-inch OD copper tubing. Coils are factory pressure and leak tested.

## Fan

The blower housing is forward curved, dynamically balanced with a variable speed direct drive fan motor. The fan motor is permanently lubricated.

## Controls

Low voltage terminal board, fan contactor, and plug-in module for accessory electric heat control is included. 2/4TEE3F models also have a check valve.

## Filters

The 2/4TEE3F31 through 2/4TEE3F65 have standard size filters.

## Electric Heaters

Heaters for the 2/4TEE3F air handlers are available in a wide range of capacities and voltages with various staging options, and plug-in control wiring. Heaters fit inside the internal compartment.



---

02/09

---

---

---

---