

Installer's Guide

Condensing Units

4TWR5

ALL phases of this installation must comply with NATIONAL, STATE AND LOCAL CODES

IMPORTANT—This Document is **customer property** and is to remain with this unit. Please return to service information pack upon completion of work.

These instructions do not cover all variations in systems nor provide for every possible contingency to be met in connection with installation. All phases of this installation must comply with NATIONAL, STATE AND LOCAL CODES. Should further information be desired or should particular problems arise which are not covered sufficiently for the purchaser's purposes, the matter should be referred to your installing dealer or local distributor.

A. GENERAL

⚠ WARNING

This information is intended for use by individuals possessing adequate backgrounds of electrical and mechanical experience. Any attempt to repair a central air conditioning product may result in personal injury and or property damage. The manufacturer or seller cannot be responsible for the interpretation of this information, nor can it assume any liability in connection with its use.

NOTICE:

Trane has always recommended installing Trane approved matched indoor and outdoor systems.

The benefits of installing approved matched systems are maximum efficiency, optimum performance and best overall system reliability.

⚠ WARNING

These units use R-410A refrigerant which operates at 50 to 70% higher pressures than R-22. Use only R-410A approved service equipment. Refrigerant cylinders are painted a rose color to indicate the type of refrigerant and may contain a dip tube to allow for charging of liquid refrigerant into the system. All R-410A systems use a POE oil that readily absorbs moisture from the atmosphere. To limit this hygroscopic action, the system should remain sealed whenever possible. If a system has been open to the atmosphere for more than 4 hours, the compressor oil must be replaced. Never break a vacuum with air and **always** change the driers when opening the system for component replacement. For specific handling concerns with R-410A and POE oil, reference Retrofit Bulletin SSC-APG011-EN.

Check for transportation damage after unit is uncrated. Report promptly, to the carrier, any damage found to the unit.

To determine the electrical power requirements of the unit, refer to the nameplate of the unit. The electrical power available must agree with that listed on the nameplate.

⚠ CAUTION

UNIT CONTAINS R-410A REFRIGERANT!

R-410A OPERATING PRESSURE EXCEEDS THE LIMIT OF R-22. PROPER SERVICE EQUIPMENT IS REQUIRED. FAILURE TO USE PROPER SERVICE TOOLS MAY RESULT IN EQUIPMENT DAMAGE OR PERSONAL INJURY.

SERVICE

USE ONLY R-410A REFRIGERANT AND APPROVED POE COMPRESSOR OIL.

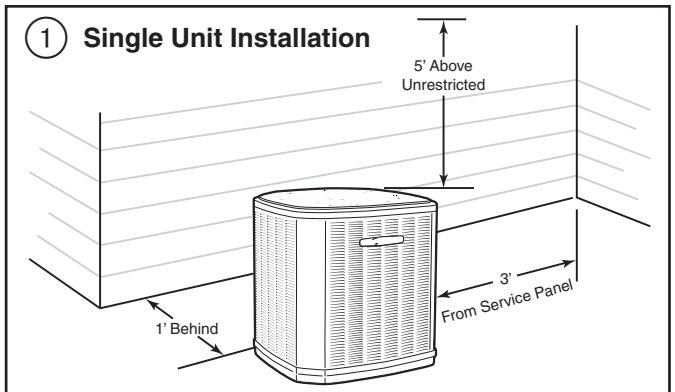

B. LOCATION AND PREPARATION OF THE UNIT

Cold Climate Considerations

The Heat Pump has been designed and manufactured to withstand and operate in severe winter conditions. However, there are precautionary steps which should be taken at the time of installation which will help assure the efficient operation of the unit. **It is recommended that these precautions be taken for units being installed in areas where snow accumulation and prolonged below freezing temperatures occur.**

1. Units should be elevated three (3) to twelve (12) inches above the pad or rooftop, depending on local weather. This additional height will allow drainage of snow and ice (melted during defrost cycle) prior to its refreezing. This reduces the chance of ice build-up around the unit which occurs when unit is not elevated. **Ensure that drain holes in unit base pan are not obstructed preventing draining of defrost water.**

Installer's Guide



2. If possible, avoid locations that are likely to accumulate snow drifts. If not possible, a snow drift barrier should be installed around the unit to prevent a build-up of snow on the sides of the unit and should be of sufficient distance from the unit to prevent restriction of airflow to and from the unit (see note 3, next section). Also allow for proper maintenance space. The barrier should be constructed of materials which will blend in with the building design.
3. Avoid locating the unit where condensation and freezing of defrost vapor may annoy the customer. For instance, installing the unit under a bedroom, kitchen, or picture window may be annoying to the customer since condensate and fog will occur during the defrost cycle.
4. Avoid locating the unit under the eaves or other overhead structures as sizeable icicles may form and the unit may be damaged by these falling icicles.

General Considerations

1. When removing unit from the pallet, notice the tabs on the basepan. Remove tabs by cutting with a sharp tool as shown in Figure 2.
2. The unit should be set on a level support pad at least as large as the unit base pan, such as a concrete slab. If this is not the application used please refer to application bulletin SSC-APG002-EN.
3. The support pad must NOT be in direct contact with any structure. Unit must be positioned a minimum of 12" from any wall or surrounding shrubbery to ensure adequate airflow. Clearance must be provided in front of control box (access panels) & any other side requiring service access to meet National Electrical Code. Also, the unit location must be far enough away from any structure to prevent excess roof run-off water from pouring directly on the unit. Do not locate unit(s) close to bedroom(s).
4. The top discharge area must be unrestricted for at least five (5) feet above the unit.
5. When the outdoor unit is mounted on a roof, be sure the roof will support the unit's weight. Properly selected isolation is recommended to prevent sound or vibration transmission to the building structure.
6. The maximum length of refrigerant lines from outdoor to indoor unit should NOT exceed sixty (60) feet.
7. If outdoor unit is mounted above the air handler, maximum lift should not exceed sixty (60) feet (suction line). If air handler is mounted above condensing unit, maximum lift should not exceed sixty (60) feet (liquid line).

NOTE:

Refer to "Refrigerant Piping Software" Pub. No. 32-3312-0* (the position of the * denotes the latest revision number).

8. Locate and install indoor coil or air handler in accordance with instruction included with that unit.

C. INSTALLING REFRIGERANT LINES

⚠ CAUTION

If using existing refrigerant lines make certain that all joints are brazed, not soldered.

Condensing units have provisions for braze connections.

Pressure taps are provided on the service valves of outdoor unit for compressor suction and liquid pressures.

The indoor end of the recommended refrigerant line sets may be straight or with a 90 degree bend, depending upon situation requirements. This should be thoroughly checked out before ordering refrigerant line sets.

The gas line must always be insulated.

⚠ CAUTION

In scroll compressor applications, dome temperatures may be hot. Touching the top of the compressor may cause minor to severe burning.

The units are factory charged with the system charge required when using fifteen (15) feet of rated connecting line with the smallest rated indoor combination.

Final refrigerant charge adjustment is necessary. Use the Subcooling Charging procedure on page 6 or in the outdoor unit Service Facts.

1. Determine the most practical way to run the lines.
2. Consider types of bends to be made and space limitations.

NOTE:

Large diameter tubing will be very difficult to rebend once it has been shaped.

3. Determine the best starting point for routing the refrigerant tubing — INSIDE OR OUTSIDE THE STRUCTURE.
4. Provide a pull-thru hole of sufficient size to allow both liquid and gas lines.
5. Be sure the tubing is of sufficient length.
6. Uncoil the tubing — do not kink or dent.
7. Route the tubing making all required bends and properly secure the tubing before making connections.
8. To prevent a noise within the building structure due to vibration transmission from the refrigerant lines, the following precautions should be taken:
 - a. When the refrigerant lines have to be fastened to floor joists or other framing in a structure, use isolation type hangers.
 - b. Isolation hangers should also be used when refrigerant lines are run in stud spaces or enclosed ceilings.
 - c. Where the refrigerant lines run through a wall or sill, they should be insulated and isolated.
 - d. Isolate the lines from all ductwork.

D. SERVICE VALVE OPERATION

BRASS LIQUID AND GAS LINE SERVICE VALVES

The Brass Liquid and Gas Line Service Valves are factory shipped in the seated position to hold factory charge. The pressure tap service port (when depressed) opens only to the field brazing side of the valve when the valve is in the seated position. The liquid line valve is **not** a back seating valve (see **WARNING** below).

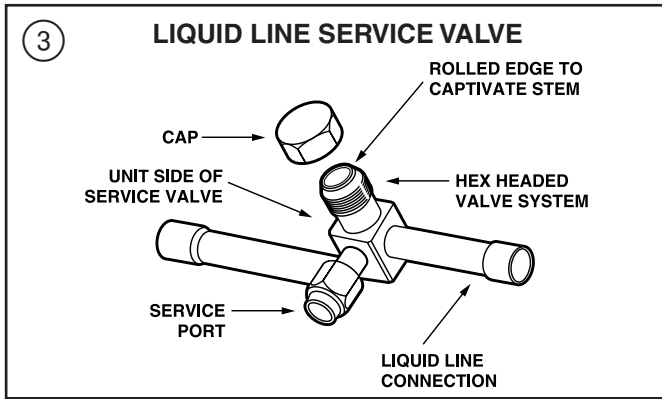

⚠ WARNING

Extreme caution should be exercised when opening the Liquid Line Service Valve. Turn valve stem counterclockwise only until the stem contacts the rolled edge. (See Figure 3.) No torque is required. Failure to follow this warning will result in abrupt release of system charge and may result in personal injury and/or property damage.

BRASS GAS LINE BALL SERVICE VALVE

The Brass Gas Line Ball Service Valve is shipped in the closed position to hold the factory refrigerant charge. The pressure tap service port (when depressed) opens only to the field brazing side when the valve is in the closed position. The Gas Line Ball Service Valve is full open with a 1/4 turn. See Figure 4.

BRAZING REFRIGERANT LINES

1. Before brazing, remove plugs from external copper stub tubes. Clean internal and external surfaces of stub tubes prior to brazing.
2. Cut and fit tubing, minimizing the use of sharp 90° bends.
3. Insulate the entire gas line and its fittings.
4. Do **NOT** allow uninsulated liquid line to come in direct contact with bare gas line.
5. **Precautions should be taken to avoid heat damage to the pressure tap valve core during brazing. It is recommended that the pressure tap port valve core be removed and a wet rag wrapped around the valve body.**

NOTE:

Use care to make sure that no moisture enters pressure tap port, while wet rag is being used.

NOTE:

Precautions should be taken to avoid heat damage to basepan during brazing. It is recommended to keep the flame directly off of the basepan.

6. Use a Dry Nitrogen Purge and Brazing Alloy without flux when brazing the field line to the copper factory connection. Flow dry nitrogen into either valve pressure tap port, thru the tubing and out the other port while brazing.
7. Braze using accepted good brazing techniques.

LEAK CHECK

IMPORTANT:

Replace pressure tap port valve core before attaching hoses for evacuation.

After the brazing operation of refrigerant lines to both the outdoor and indoor units is completed, the field brazed connections must be checked for leaks. Pressurize through the service valve ports, the indoor unit and field refrigerant lines

with dry nitrogen to 350-400 psi. Use soap bubbles or other leak-checking methods to see that all field joints are leak-free! If not, **release pressure**; then repair!

SYSTEM EVACUATION

NOTE:

Since the outdoor unit has a refrigerant charge, the gas and liquid line valves must remain closed.

1. Upon completion of leak check, evacuate the refrigerant lines and indoor coil before opening the gas and liquid line valves.
2. Attach appropriate hoses from manifold gauge to gas and liquid line pressure taps.

NOTE:

Unnecessary switching of hoses can be avoided and complete evacuation of all lines leading to sealed system can be accomplished with manifold center hose and connecting branch hose to a cylinder of R-410A and vacuum pump.

3. Attach center hose of manifold gauges to vacuum pump.
4. Evacuate until the micron gauge reads no higher than 350 microns.
5. Close off valve to vacuum pump and observe the micron gauge. If gauge pressure rises above 500 microns in one (1) minute, then evacuation is incomplete or system has a leak.
6. If vacuum gauge does not rise above 500 microns in one (1) minute, the evacuation should be complete.
7. Blank off vacuum pump and micron gauge, close valves on manifold gauge set.

NOTE:

DO NOT VENT REFRIGERANT INTO THE ATMOSPHERE.

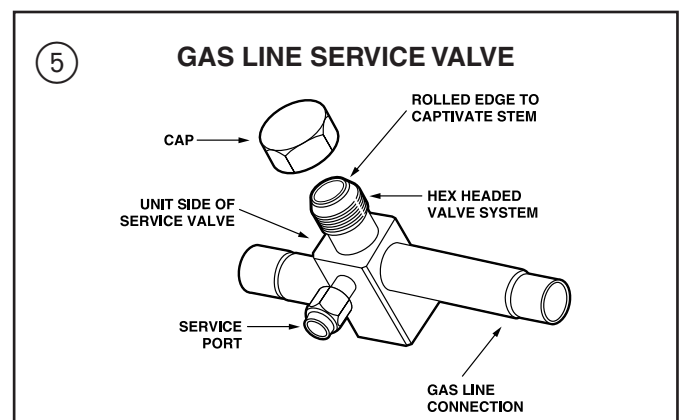
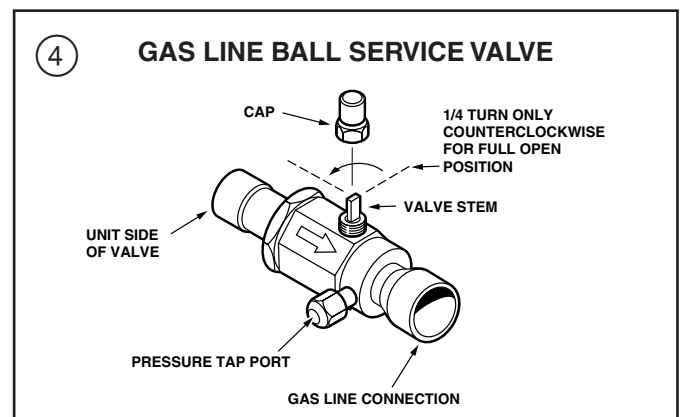

Installer's Guide

NOTE:

A 3/16" Allen wrench is required to open liquid line service valve. A 1/4" Open End or Adjustable wrench is required to open gas line valve. A 3/4" Open End wrench is required to take off the valve stem cap.

8. The liquid line shut-off valve can now be opened. Remove shut-off valve cap. Fully insert hex wrench into the stem and backout counterclockwise until valve stem just touches rolled edge (approximately five [5] turns) observing **WARNING** statement on page 2. See Figure 3.
9. Replace liquid service pressure tap port cap and valve stem cap. These caps **MUST BE REPLACED** to prevent leaks. Replace valve stem cap and pressure tap cap finger tight, then tighten an additional 1/6 turn.
10. The gas valve can now be opened. Open the gas valve by removing the shut-off valve cap and turning the valve stem 1/4 turn counterclockwise, using 1/4" Open End or Adjustable wrench. See Figures 4 and 5.
11. The gas valve is now open for refrigerant flow. Replace valve stem cap to prevent leaks. Again, these caps **MUST BE REPLACED** to prevent leaks. Replace valve stem cap and pressure tap cap finger tight, then tighten an additional 1/6 turn. See Figures 4 and 5.

If refrigerant lines are longer than fifteen (15) feet and/or a different size than recommended, it will be necessary to adjust system refrigerant charge upon completion of installation. See page 6 or the unit Service Facts.

E. ELECTRICAL CONNECTIONS

⚠ WARNING

When installing or servicing this equipment, ALWAYS exercise basic safety precautions to avoid the possibility of electric shock.

1. Power wiring and grounding of equipment must comply with local codes.
2. Power supply must agree with equipment nameplate.
3. Install a separate disconnect switch at the outdoor unit.
4. Ground the outdoor unit per local code requirements.
5. Provide flexible electrical conduit whenever vibration transmission may create a noise problem within the structure.
6. The use of color coded low voltage wire is recommended to simplify connections between the outdoor unit, the thermostat and the indoor unit.

Table 1 — NEC Class II Control Wiring

24 VOLTS	
WIRE SIZE	MAX. WIRE LENGTH
18 AWG	150 FT
16 AWG	225 FT.
14 AWG	300 FT.

7. Table 1 defines maximum **total** length of low voltage wiring from outdoor unit, to indoor unit, and to thermostat.
8. Mount the indoor thermostat in accordance with instruction included with the thermostat. Wire per appropriate hook-up diagram (included in these instructions).

F. DEFROST CONTROL

The demand defrost control measures heat pump outdoor ambient temperature with a sensor located outside the outdoor coil. A second sensor located on the outdoor coil is used to measure the coil temperature. The difference between the ambient and the colder coil temperature is the difference or delta-T measurement. This delta-T measurement is representative of the operating state and relative capacity of the heat pump system. By measuring the change in delta-T, we can determine the need for defrost. The coil sensor also serves to sense outdoor coil temperature for termination of the defrost cycle.

TERMINATION TEMPERATURE

Defrost controls have a selectable termination temperature. As shipped, defrost will terminate at 47°F. For a higher termination temperature, cut Jumper J2 to achieve 70°F when at or below 30°F ambient. See Service Facts shipped in the outdoor unit for more information.

FAULT IDENTIFICATION

A fault condition is indicated by the flashing light on the defrost control inside the heat pump control box.

In normal operation, the defrost control light will flash once each second. If the light is flashing more than once per second or not at all, refer to the Service Facts.

PIN IDENTIFICATION (See Figure 6.)

1. TEST_COMMON (Shorting any of the other pins to this pin causes the function of the other pin to be executed. Leaving this pin open results in the normal mode of operation.)

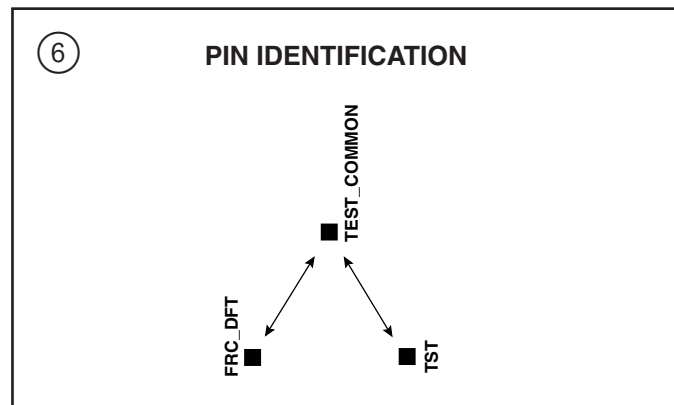

2. TST = Test (Shorting TEST_COMMON to this pin speeds up all defrost board timings.)
3. FRC_DFT = Forced Defrost (Short TEST_COMMON to this pin for two [2] seconds to initiate a forced defrost. Remove the short after defrost initiates.)

DEFROST CONTROL CHECKOUT

Normal operation requires:

- a. LED on board flashing 1 time/second.
- b. 24V AC between R & B.
- c. 24V AC between Y & B with unit operating.
- d. Defrost initiation when FRC_DFT pin is shorted to TEST_COMMON pin.

If a defrost control problem is suspected, refer to the service information in control box.

TYPICAL FIELD HOOK-UP DIAGRAMS

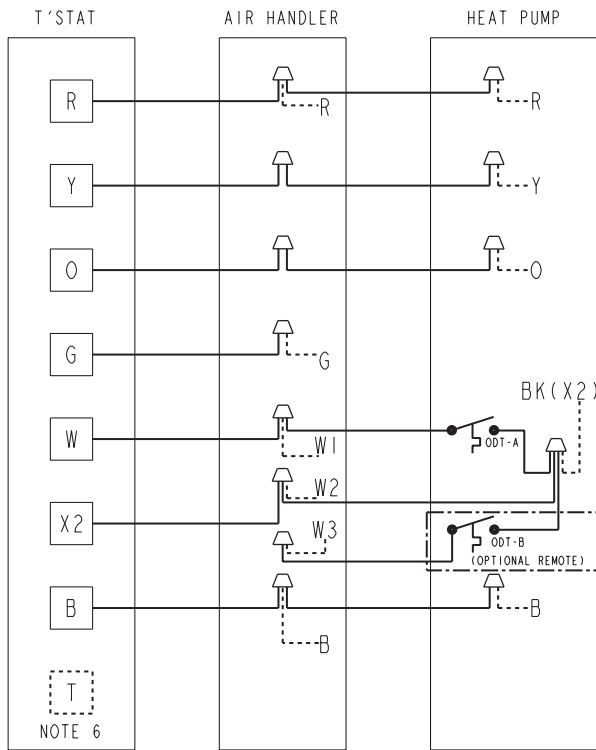

PRINTED FROM B152904P04

Notes:

1. Be sure power supply agrees with equipment nameplate.
2. Power wiring and grounding of equipment must comply with local codes.
3. Low voltage wiring to be No. 18 AWG minimum conductor.
4. ODT-B must be set lower than ODT-A.
5. If outdoor thermostats (ODT) are not used, connect W1 to W2 and W3.
6. If t-stat has a "T" terminal jumper it to the "B" terminal.

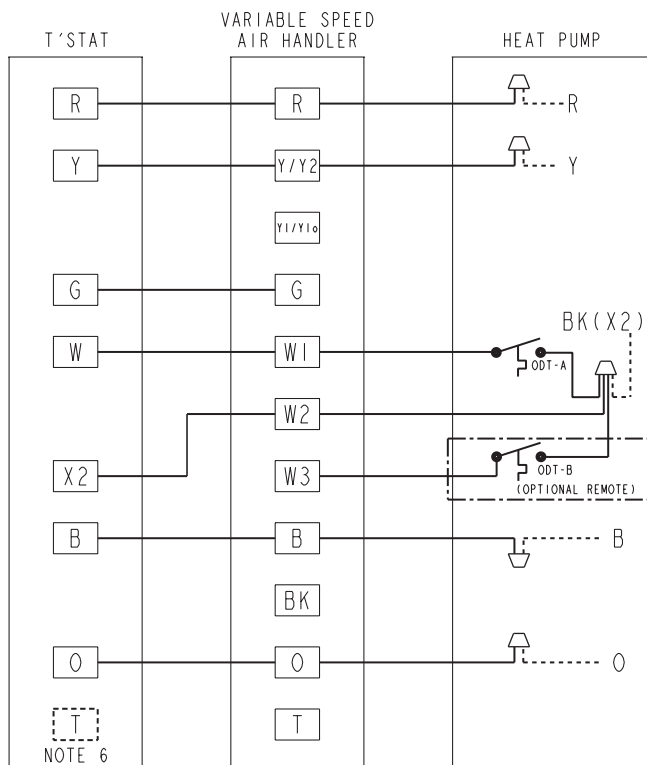

PRINTED FROM B152934P05

LEGEND

- FACTORY WIRING
- FIELD WIRING

Installer's Guide

G. COMPRESSOR START-UP

After all electrical wiring is complete, SET THE THERMOSTAT SYSTEM SWITCH IN THE OFF POSITION SO COMPRESSOR WILL NOT RUN, and apply power by closing the system main disconnect switch. This will activate the compressor sump heat (where used). Do not change the Thermostat System Switch until power has been applied for one (1) hour. Following this procedure will prevent potential compressor overload trip at the initial start-up.

H. OPERATIONAL AND CHECKOUT PROCEDURES

Final phases of this installation are the unit Operational and Checkout Procedures which are found in this instruction (see table below and pages 6 and 8). To obtain proper performance, all units must be operated and charge adjustments made in accordance with procedures found on page 6 and in the Service Facts.

IMPORTANT:

Perform a final unit inspection to be sure that factory tubing has not shifted during shipment. Adjust tubing if necessary so tubes do not rub against each other when the unit runs. Also be sure that wiring connections are tight and wire routing is secure.

I. SEACOAST SHIELD

If installed within one mile of salt water, including seacoasts and inland waterways, models without factory supplied

Seacoast Salt Shields require the addition of BAYSEAC001 (Seacoast Kit) at installation time. Please refer to Application Guide SS-APB006-EN: *Trane - Seacoast Applications* and *Seacoast Corrosion Protection Bulletin UN-SVB11A-EN*.

IMPORTANT:

See Limited Warranty information in Use and Care Manual.

J. TROUBLESHOOTING

TROUBLESHOOTING CHART — WHAT TO CHECK

SYSTEM FAULTS	HIGH VOLTAGE WIRING	POWER SAFETY	RUN SAFETY	START SAFETY	CONTROL TRANSFORMER	LOW VOLTAGE WIRING	START RELAY	CONTACTOR COILS	CONTACTOR OIL	REFRIGERANT COMPRESSOR	REFRIGERANT OIL	REFRIGERANT OVERCHARGE	EXCESSIVE OIL LOAD	RESTRICTED OIL RETURN	NON CONDENSIBLES	O.D. AIR REGULATION	TXV SUCION	TXV SUPERHEAT	RESTRICTED OIL RETURN	O.D. FAN SPEED SWITCH		
REFRIGERANT CIRCUIT																						
Liquid Pressure Too High																						
Liquid Pressure Too Low										S	P								S	S	S	
Suction Pressure Too High										S	P	P							S	P		
Suction Pressure Too Low										S									S	P	S	
Liquid Refrig. Floodback TXV System																			S			
I.D. Coil Frosting																					P	S
Compressor Runs Inadequate or No Cooling										S	P	P	S						S	P	S	
ELECTRICAL																						
Compressor & O.D. Fan Do Not Start	P	P							S	P	P	P										
Compressor Will Not Start But O.D. Fan Runs	P	S	P	P	P					S												
O.D. Fan Won't Start	P		P																			
Compressor Hums But Won't Start	P		P	P	P	S				S												
Compressor Cycles on IOL	P	S	P	P	P	S				P	S	P	S	S					S		S	
I.D. Blower Won't Start	P	S							S	P	P											

P - Primary Causes S - Secondary Causes

SUBCOOLING CHARGING IN COOLING ABOVE 55°F OD AMBIENT

Trane has always recommended installing Trane approved matched indoor and outdoor systems.

All Trane split systems are AHRI rated with only TXV indoor systems.

The benefits of installing approved indoor and outdoor split systems are maximum efficiency, optimum performance and the best overall system reliability.

The following charging methods are therefore prescribed for systems with indoor TXVs.

- Subcooling (in the cooling mode) is the only recommended method of charging above 55°F ambient temperatures.
- For best results - the indoor temperature should be kept between 70°F to 80°F. Add system heat if needed.
- At start-up, or whenever charge is removed or added, the system must be operated for a minimum twenty (20) minutes to stabilize before accurate measurements can be made.
- Measure Liquid Line Temperature and Refrigerant Pressure at service valves.
- Determine total refrigerant line length, and height (lift) if indoor section is above the condenser. Use the **Subcool Charging Chart Corrections Table** to calculate any additional subcooling required for your specific application.
- Determine the Design Subcooling from the unit nameplate or Service Facts. Add any additional amount of subcooling calculated in Step 5 to the Design Subcooling to arrive at the final subcooling value.
- Locate this value in the appropriate column of the **R-410-A Refrigerant Charging Chart**. Locate your liquid line temperature in the left column of the chart, and the intersecting liquid line pressure under your calculated subcooling value column. Add refrigerant to raise the pressure to match the chart, or remove refrigerant to lower the pressure. Again, wait twenty (20) minutes for the system conditions to stabilize before adjusting charge again.
- When system is correctly charged, you can refer to System Pressure Curves (in Service Facts) to verify typical performance.

R-410A REFRIGERANT CHARGING CHART							
LIQUID TEMP (°F)	DESIGN SUBCOOLING (°F)						
	8	9	10	11	12	13	14
LIQUID GAGE PRESSURE (PSI)							
55	179	182	185	188	191	195	198
60	195	198	201	204	208	211	215
65	211	215	218	222	225	229	232
70	229	232	236	240	243	247	251
75	247	251	255	259	263	267	271
80	267	271	275	279	283	287	291
85	287	291	296	300	304	309	313
90	309	313	318	322	327	331	336
95	331	336	341	346	351	355	360
100	355	360	365	370	376	381	386
105	381	386	391	396	402	407	413
110	407	413	418	424	429	435	441
115	435	441	446	452	458	464	470
120	464	470	476	482	488	495	501
125	495	501	507	514	520	527	533
Refer to Service Facts or Installer's Guide for charging method.							

From Dwg. D154557P01 Rev. 3

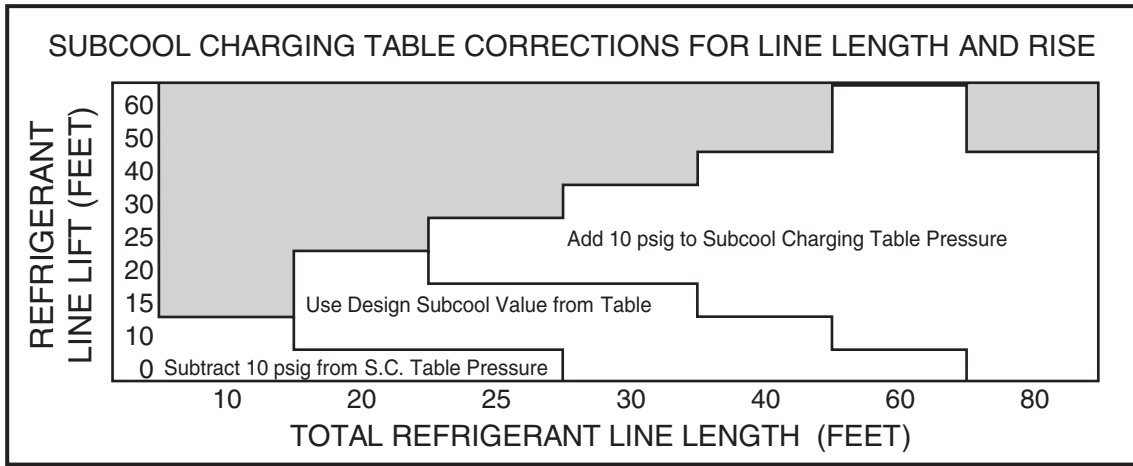

4TWR5 OUTLINE DRAWING

NOTE: ALL DIMENSIONS ARE IN MM (INCHES).

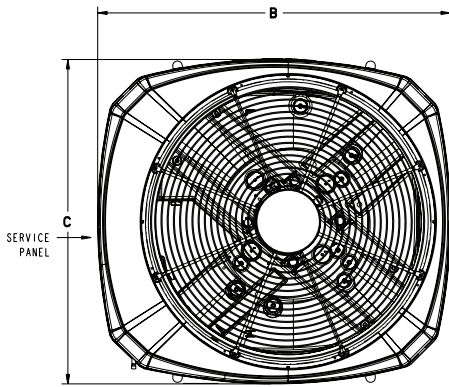

TOP DISCHARGE AREA SHOULD BE UNRESTRICTED FOR AT LEAST 1524 (5 FEET) ABOVE UNIT. UNIT SHOULD BE PLACED SO ROOF RUN-OFF WATER DOES NOT POUR DIRECTLY ON UNIT, AND SHOULD BE AT LEAST 305 (12") FROM WALL AND ALL SURROUNDING SHRUBBERY ON TWO SIDES. OTHER TWO SIDES UNRESTRICTED.

ELECTRICAL AND REFRIGERANT COMPONENT CLEARANCES PER PREVAILING CODES.

FIG. 1

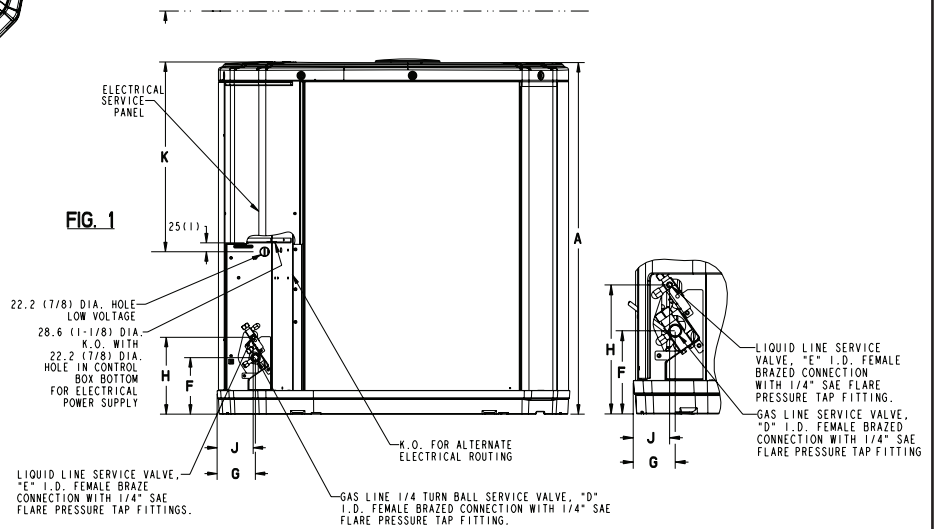

MODELS	BASE	A	B	C	D	E	F	G	H	J	K
4TWR5018E	4	841 (33-1/8)	946 (37-1/4)	870 (34-1/4)	1/2	3/8	152 (6)	98 (3-7/8)	219 (8-5/8)	86 (3-3/8)	508 (20)
4TWR5024E	4	841 (33-1/8)	946 (37-1/4)	870 (34-1/4)	5/8	3/8	152 (6)	98 (3-7/8)	219 (8-5/8)	86 (3-3/8)	508 (20)
4TWR5030E	4	1045 (41 1/8)	946 (37-1/4)	870 (34-1/4)	3/4	3/8	152 (6)	98 (3-7/8)	219 (8-5/8)	86 (3-3/8)	508 (20)
4TWR5036E	4	1045 (41 1/8)	946 (37-1/4)	870 (34-1/4)	3/4	3/8	152 (6)	98 (3-7/8)	219 (8-5/8)	86 (3-3/8)	508 (20)
4TWR5042E	4	1045 (41 1/8)	946 (37-1/4)	870 (34-1/4)	3/4	3/8	152 (6)	98 (3-7/8)	219 (8-5/8)	86 (3-3/8)	508 (20)
4TWR5048E	4	1147 (45 1/8)	946 (37-1/4)	870 (34-1/4)	7/8	3/8	152 (6)	98 (3-7/8)	219 (8-5/8)	86 (3-3/8)	508 (20)
4TWR5060E	4	1147 (45 1/8)	946 (37-1/4)	870 (34-1/4)	7/8	3/8	152 (6)	98 (3-7/8)	219 (8-5/8)	86 (3-3/8)	508 (20)

From Dwg. D156010

Installer's Guide

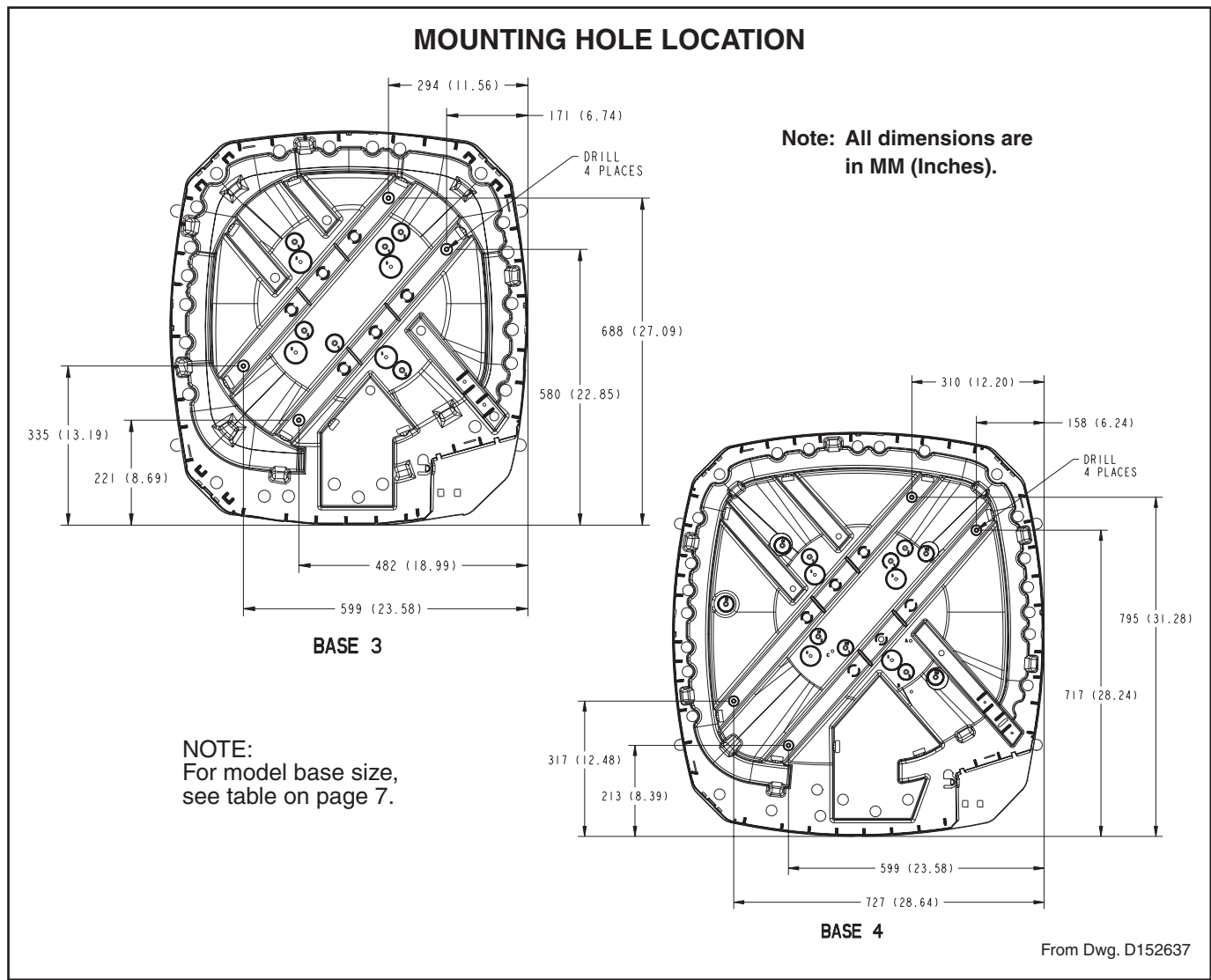

CHECKOUT PROCEDURE

After installation has been completed, it is recommended that the entire system be checked against the following list:

- | | |
|---|---|
| <ol style="list-style-type: none"> 1. Refrigerant Line, Leak checked [] 2. Suction Lines and Fittings properly insulated [] 3. Have all Refrigerant Lines been secured and isolated properly?..... [] 4. Have passages through masonry been sealed? If mortar is used, prevent mortar from coming into direct contact with copper tubing [] 5. Verify tightness of all electrical connects [] 6. Observe outdoor fan during on cycle for clearance and smooth operation [] 7. Indoor coil drain line drains freely. Pour water into drain pan..... [] | <ol style="list-style-type: none"> 8. Supply registers and return grilles open and unobstructed [] 9. Return air filter installed [] 10. Thermostat thermometer is accurate. Check against a reliable thermometer. Adjust per instructions with thermostat [] 11. Is correct speed tap being used? (Indoor blower motor) [] 12. Operate complete system in each mode to ensure safe operation..... [] |
|---|---|



Trane has a policy of continuous product and product data improvement and it reserves the right to change design and specifications without notice.