



Advanced Heating  
& Hot Water Systems

# High Efficiency EFT Combi Space Heating & Endless Hot Water



Durable high grade 316L stainless steel fire tube heat exchanger

Endless hot water, advanced temperature control

Advanced modulating gas condensing boiler up to 93.2% AFUE

Available in LP and Natural Gas

Equipped with highly innovative gas leak detector

Eco-friendly and low NOx combustion system

316L Stainless steel indirect storage tank (15 Gallon) which eliminates temperature fluctuation

5:1 Turndown Ratio

[www.htproducts.com](http://www.htproducts.com)



Save Energy • Save Money • Save Space • Save On Installation

# EFT Combi

## A CLOSER LOOK

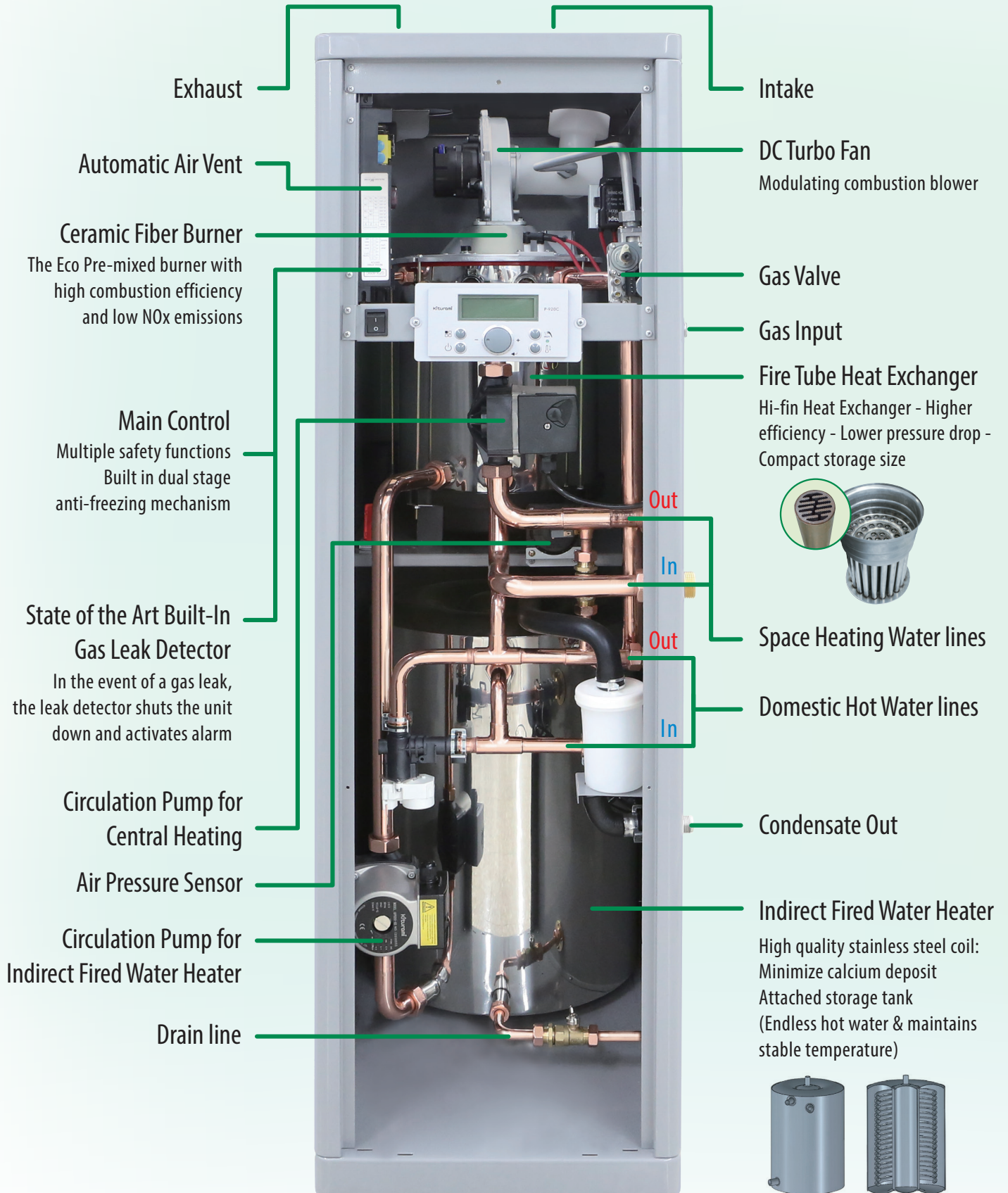

# VENT TERMINATION

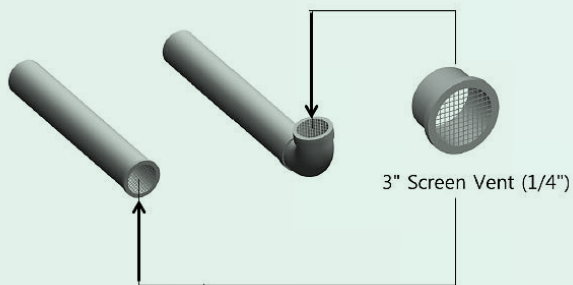
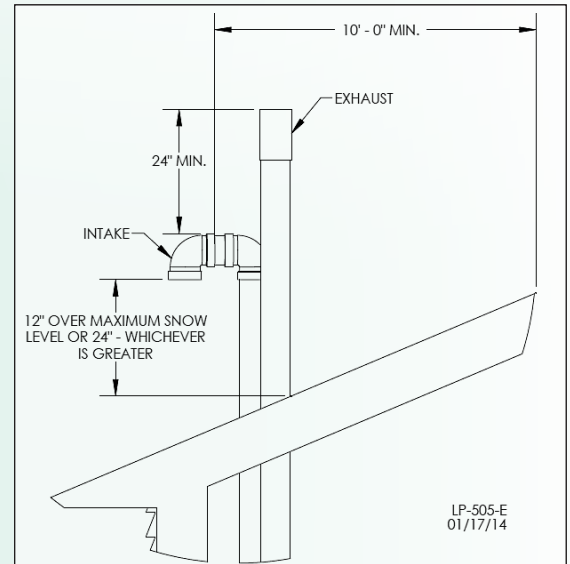
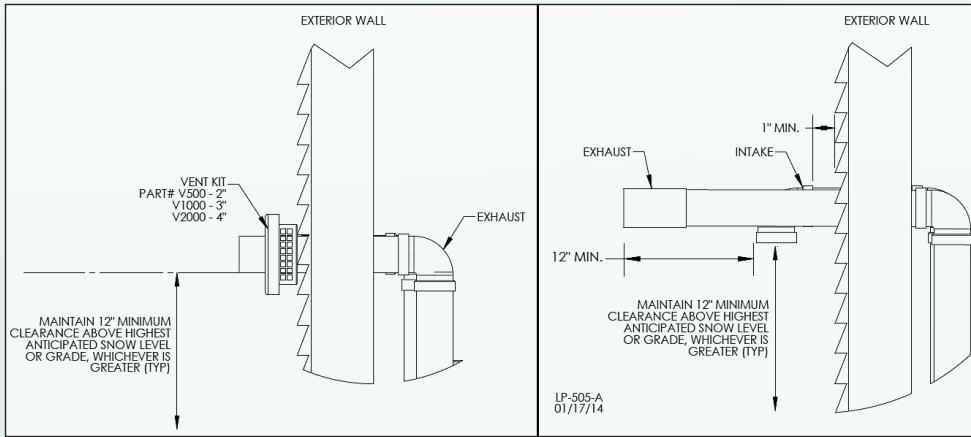

Forced Draft Direct-Vent  
2"(50ft), 3"(100ft), PVC, CPVC & PP

# MULTIFUNCTION CONTROL PANEL

**Customized Temperature Control**  
Maintain constant temperature with the user friendly Flow Control, Flow Sensor and Heat Capacity Control.

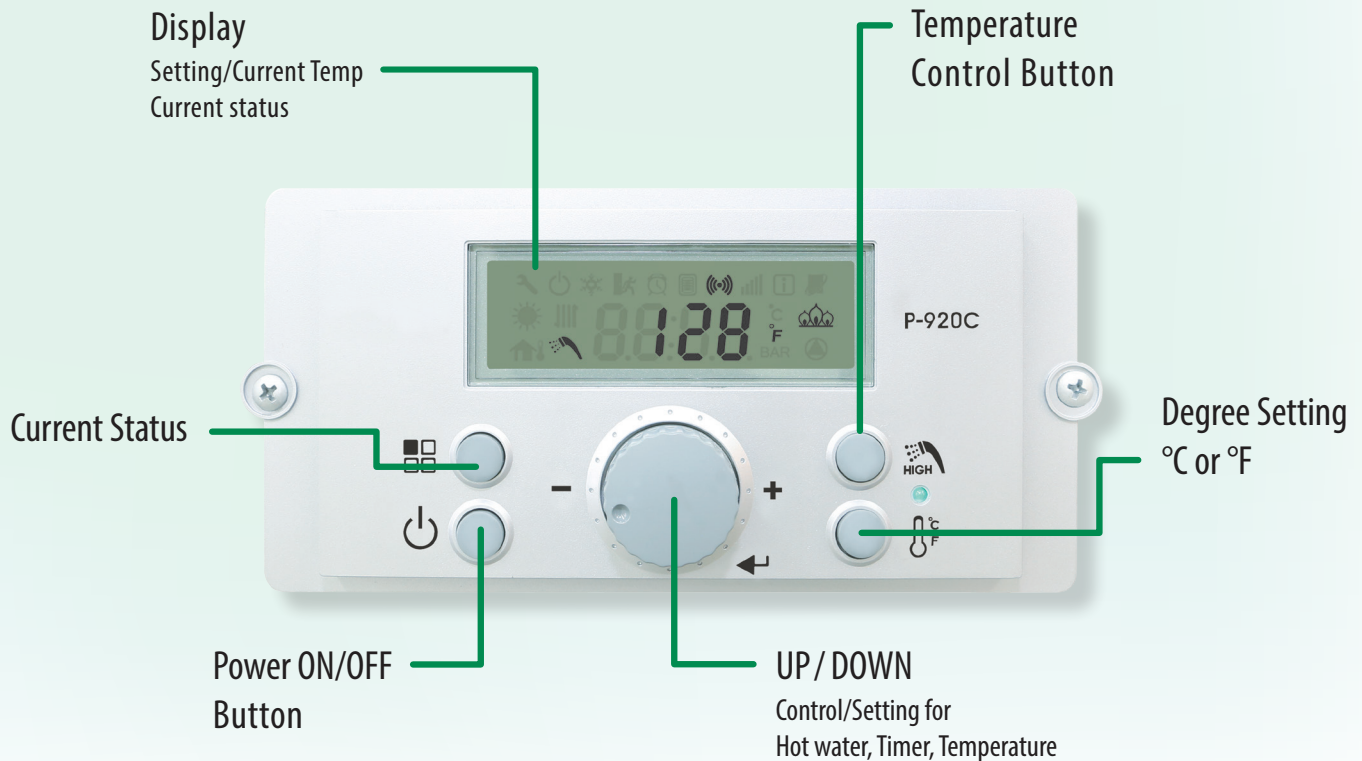

# DIMENSIONS

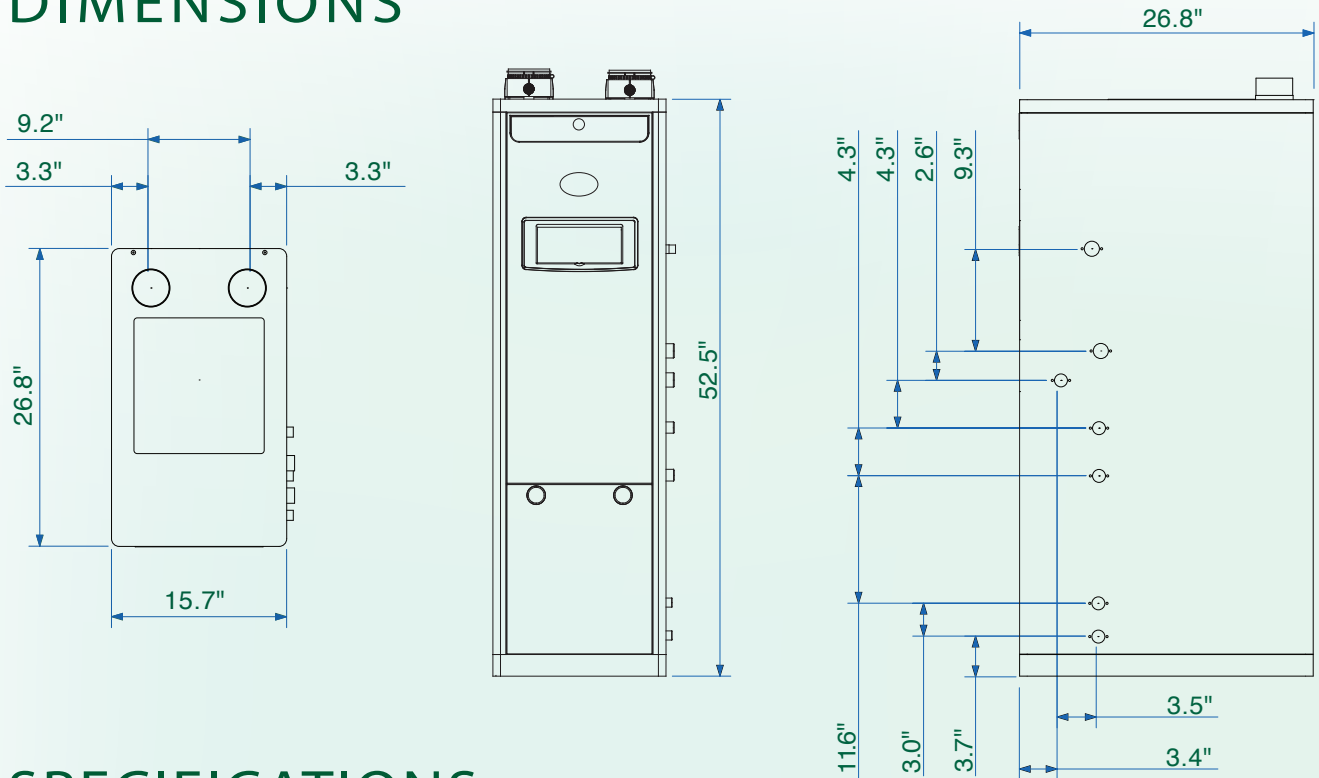

# SPECIFICATIONS

Model		EFTC -140F
Input Rate	Natural Gas, Propane Gas	28,000 ~ 140,000 Btu/hr
Dimensions		W 15.7" X H 52.5" X D 26.7"
Installation Type		Indoor / Floor Standing
Venting Type		Forced Draft Direct-Vent
Venting, Length		2"(50ft), 3"(100ft), CPVC, PVC, PP
Ignition		Electronic Ignition
Gas Supply Pressure	Natural Gas	3.5" WC ~ 14" WC
	Propane Gas	3.5" WC ~ 14" WC
Power Supply	Main Supply	AC 120V / 60Hz
	Maximum Power Consumption	160W
Flow Rate (DHW)	35° (19°) Temp Rise	7.1 GPM
	45° (25°) Temp Rise	5.5 GPM
	77° (43°) Temp Rise	3.2 GPM
Water Pressure	Space Heating	15 PSI
	Domestic Hot Water	150 PSI
Connection Sizes	Cold Water Inlet/ Hot Water Outlet	3/4" NPT
	Space Heating Supply/Return	1" NPT
	Gas Inlet	1/2" NPT (1/2" x 3/4" Bell Coupling Provided to Upsize Gas Line)
Warranty		Limited 10 Year Residential Warranty