

# Installation Instructions

## Model Number ZDV6000, ZDV3320 MQRB3328, MQRB3328T

### Zero Clearance Direct Vent Gas Fireplace

Stock #'s ZDV6000N, ZDV6000LP, MQRQB3328N, MQRB3328LP are  
certified to: ANZI Z21.88-2009, CSA2.33-2009, CGA 2.17-M91

.Acceptable for installation in Manufactured Housing (Mobile Homes) except as original equipment.

Stock #'s ZDV3320N, ZDV3320LP, MQRB3328NT, MQRB3328LPT are  
certified to: ANSI Z21.50b-2009, CSA 2.22b-2009, CGA 2.17-M91.

**INSTALLER: Leave this manual with the appliance.**  
**CONSUMER: Retain this manual for future reference.**



This appliance may be installed in an aftermarket permanently located, manufactured home (USA only) or mobile home, where not prohibited by local codes.

This appliance is only for use with the type of gas indicated on the rating plate. This appliance is not convertible for use with other gases, unless a certified kit is used.

**Read this complete manual before beginning installation.**  
**These instructions must be kept with the unit for future reference.**

## FOR YOUR SAFETY



**WARNING:** If the information in these instructions is not followed exactly, a fire or explosion may result causing property damage, personal injury or loss of life.



**WARNING:** Improper installation, adjustment, alteration, service or maintenance can cause property damage, personal injury or loss of life. Refer to this manual. Installation and service must be performed by a qualified installer, service agency or the gas supplier.

Do not store or use gasoline or other flammable vapors and liquids in the vicinity of this or any other appliance.

#### What to Do If You Smell Gas

Do not try to light any appliance.

Extinguish any open flame.

Do not touch any electrical switch.

Do not use any phone in your building.

Immediately call your gas supplier from a neighbour's phone.

If you can not reach your gas supplier, call the fire department.

**For Propane Horizontal installations the venting must be a minimum of one foot vertical off the flue before going horizontal.**



A Division of R-Co. Inc.  
2340 Logan Avenue  
Winnipeg, Manitoba, Canada R2R 2V3  
Ph: (204) 632-1962

## PRE-INSTALLATION QUESTIONS and ANSWERS

### Why does my fireplace or stove give off odour?

It is normal for your fireplace to give off some odour. This is due to the curing of the paint, adhesives, silicones and any undetected oil from the manufacturing process as well as the finishing materials used with the installations (e.g. marble, tile and the adhesives used to adhere this product to the walls can react with heat and cause odours).

It is recommended that you burn your gas fireplace or stove for a minimum of four hours at a time with the fan off after the curing of the paint has been completed. These odours can last upward to 40 hours of burn time, keep burning at a minimum of four hours per use until odours dissipate.

### About curing of the paint

Your stove or fireplace has been painted with the highest quality silicone stove paint. This paint dries quickly in 15-20 minutes when first applied at the factory. However, due to the high temperature silicone components, the paint will cure when heat is applied to the appliance as it is first used.

The following information **applies to the curing process** to get the paint fully hard and durable.

Fire the appliance four successive times for 10 minutes each firing and a 5 minute cool down between each. Be aware during log and firebox paint curing that a white deposit may be developing on the inside of the glass doors. It is important to remove this white deposit from the glass doors with an appropriate cleaner to prevent build-up (such as Windex or a commercial fireplace glass cleaner).

- Babies, small children, pregnant women and pets should leave the area during the cure phase.
- Ventilate well, open doors and windows.
- Do not touch during curing.

### Noise coming from the fireplace?

- Noise caused by metal expanding and contracting as it heats up and cools down, similar to the sound produced by a furnace or heating duct. This noise does not affect the operation or longevity of your fireplace.
- Different types and thicknesses of steel will expand and contract at different rates resulting in “cracking” and “ticking” sounds throughout the heating and cooling periods.
- You should also be aware that as temperatures change within the unit these sounds will likely re-occur. Again this is normal for steel fireboxes, and is not a defect.

### Cleaning the Glass

During the first few fires, a white film may develop on the glass front, as part of the curing process. The glass should be cleaned after the unit has cooled down or the film can bake on and become very difficult to remove. Use a non-abrasive cleaner and do not attempt to clean the glass while it is hot.

## Table of Contents

Mobile Home/Manufactured Housing Installation . . . . .	4
Warnings, Installations & Operations . . . . .	5
Operations & Maintenance Instructions . . . . .	6
Installation Requirements for the Commonwealth of Massachusetts . . . . .	6
Locating your appliance . . . . .	7
Framing your gas fireplace . . . . .	8-10
Installing the Clean View Kit(CVCK) . . . . .	11
Mantel & Surround Clearances . . . . .	12
Clearance to Combustibles . . . . .	13
MQ33SW Wall Mount Surround Dimensions and Installation . . . . .	14
Fan Kit Installation . . . . .	15
Installing Brick and Porcelain Panel . . . . .	16
Installing MQRB3328 Liner Panels . . . . .	17
Gas Line Installation . . . . .	18
General Glass Information . . . . .	18
Millivolt System, Lighting, & Burner Control . . . . .	19
Gas Conversion - ZDV3320/ZDV6000/MQRB3328 . . . . .	20
Conversion Kit Instructions . . . . .	21
IPI Electronic Ignition System . . . . .	22-26
IPI Lighting Instructions . . . . .	27
Trouble Shooting the Gas Control System . . . . .	28
Field Conversion for ZDV6000-VFI25-VFI30 . . . . .	29
LogC5 Or LogF5 for ZDV6000 . . . . .	30
LOGC6 for ZDV6000 . . . . .	31
MQROCK1/MQRSP6 for ZDV6000 . . . . .	32-33
LOGC42/LOGC43 for ZDV3320 . . . . .	34-35
LOGC44 for ZDV3320 . . . . .	35-36
MQROCK1/MQRSP3 for ZDV3320 . . . . .	37-38
Accessories for MQRB3328/3632/4236 . . . . .	39
Vent Termination . . . . .	40
General Vent Installation Information . . . . .	41
Installation of Side Wall Venting . . . . .	41-42
Installation of venting straight up through Roof . . . . .	43
Parts List . . . . .	44-46
Kingsman Industries Gas Fireplace – Limited Warranty . . . . .	47

## Mobile Home/Manufactured Housing Installation

This Direct Vent System Appliance must be installed in accordance with the manufacturer's installation instructions and the Manufactured Home Construction and Safety Standard Title 24 CFR, Part 3280, or the current Standard for Fire Safety Criteria for Manufactured Home Installations, Sites, and Communities ANSI/NFPA 501A, and with CAN/CSA Z240 MH Mobile Home Standard in Canada.

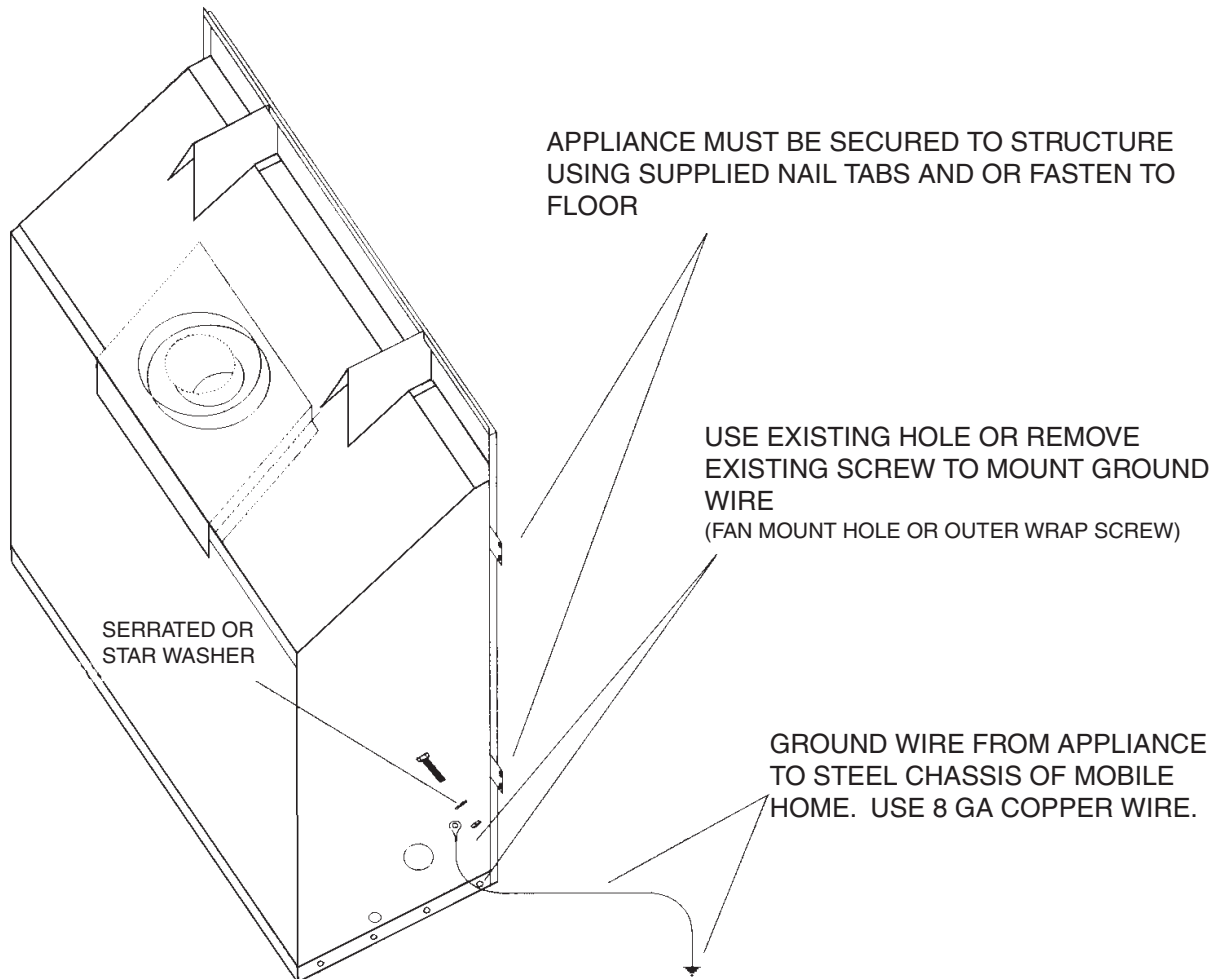

### **THIS APPLIANCE MAY BE INSTALLED IN MANUFACTURED (MOBILE) HOMES AFTER FIRST SALE.**

Please follow the current ANSI/NFPA 70 National Electrical Code in the USA and CAN/CSA C22.1 Canadian National Electrical Code in Canada.

An appliance must be grounded to the steel chassis of the home with 8 ga. copper wire using a serrated or star washer to penetrate paint or protective coating to insure grounding.

Use carriage bolt at the attachment point (see diagram above) to secure the appliance to the floor.



**WARNING:** Do not compromise the structural integrity of the manufactured home wall, floor or ceiling, during installation of appliance or venting.

*For required venting components see venting installation in appropriate section of this manual.*

## Warnings, Installations, and Operations

### Installation Regulations

This gas appliance must be installed by a qualified installer in accordance with local building codes, or in the absence of local codes, with the current CAN/CGA-B149.1 Installation Code (in Canada) or the current National Fuel Gas Code Z223.1 when installed in the United States.

This appliance, when installed, must be electrically connected and grounded in accordance with local codes, or in the absence of local codes, with the current CSA C22.1 Canadian Electrical Code or with the national Electrical Code; ANSI/NFPA 70-1987 when installed in the United States.

### **Warning**

**FOR SAFE INSTALLATION AND OPERATION OF YOUR GAS FIREPLACE PLEASE NOTE THE FOLLOWING:**

1. Do not clean when the glass is hot.
2. Do not use abrasive cleaners.
3. Using a substitute glass will void all product warranties.
4. For safe operation, glass doors must be closed.
5. When purging the gas line, the glass front must be removed.
6. Do not strike or abuse glass. Take care to avoid breakage.
7. Do not alter gas orifice.
8. No substitute materials may be used other than factory supplied components.
9. This appliance gives off high temperatures and should be located out of heavy traffic areas and away from furniture and draperies.
10. Children and adults should be alerted to the hazards of the high surface temperatures of this appliance and should stay away to avoid burns or ignition of clothing.
11. Young children should be carefully supervised when they are in the same room as the appliance. Toddlers, young children and others may be susceptible to accidental contact burns. A physical barrier is recommended if there are at risk individuals in the house. To restrict access to a fireplace or stove, install an adjustable safety gate to keep toddlers, young children and other at risk individuals out of the room and away from hot surfaces.
12. Under no circumstances should any solid fuels (wood, paper) be used in this appliance.
13. Under no circumstances should this appliance be modified. Any parts that have to be removed for servicing should be replaced prior to operating this appliance.
14. Installation and repair should be done by a qualified service person. The appliance should be inspected before use and at least annually by a professional service person. More frequent cleaning may be required due to excessive lint from carpeting, bedding material, et cetera. It is imperative that control compartments, burners and circulating air passageways of the appliance be kept clean. Make sure that the gas valve and pilot light are turned off before you attempt to clean this unit.
15. Clothing or other flammable material should not be placed on or near the appliance. This appliance should not be used as a drying rack for clothing nor should Christmas stockings or decorations be hung from it.
16. Do not use this heater if any part has been under water. Immediately call a qualified service technician to inspect the heater and to replace any part of the control system and any gas control which has been under water.
17. Do not operate appliance unless completely installed as per installation instructions.
18. Failure to position the parts in accordance with these diagrams or failure to use only parts specifically approved with this appliance may result in property damage or personal injury.
19. Do not operate appliance with the glass front removed, cracked or broken. Replacement of the glass should be done by a licensed or qualified service person.
20. The front of the fireplace gives off high temperatures that could ignite combustible material which is kept close to the front of the unit.
21. Ensure that power to the Fireplace is turned off before servicing.
22. Do not operate this Fireplace without the glass front or with a broken glass.
23. Improper installation, adjustment, alteration, service or maintenance can cause injury or property damage. Refer to the owner's information manual provided with this appliance. For assistance or additional information consult a qualified installer, service agency, or the gas supplier.
24. Operation of this appliance when not connected to a properly installed and maintained venting system or tampering with the blocked vent shutoff system can result in carbon monoxide (CO) poisoning and possible death.



- Gas fired appliances may be used only for supplemental heat and/or decorative purposes and under no circumstances shall they provide a primary heat source.
- This appliance must not be connected to a chimney flue serving a separate solid-fuel burning appliance.

NOTE: It is recommended that a Carbon Monoxide (CO) Detector be installed in or near bedrooms and on all levels of your home. Place a detector about 15ft [4.5m] outside the room that houses your gas appliance.

Certified for installation in a bedroom or bed/sitting room. In Canada must be installed with listed millivolt thermostat. In USA see local codes.

## Operations and Maintenance Instructions

For safe installation and operation note the following:

- The Burner/Log Assembly has been engineered and permanently adjusted for proper flame control.
- Periodically remove the logs from the grate assembly and vacuum any loose particles from the grate and burner areas. See Log Placement page to remove logs. Vacuum burner parts and replace logs.
- Never use our gas fireplace as a cooking device.
- Label all wires prior to disconnection when servicing controls. Wiring errors can cause improper and dangerous operation. Verify proper operation after servicing.

## Installation Requirements for the Commonwealth of Massachusetts

In the Commonwealth of Massachusetts, the installer or service agent shall be a plumber or gas fitter licensed by the Commonwealth.

When installed in the Commonwealth of Massachusetts or where applicable codes; the unit shall be installed with a CO detector per the requirements listed below.

1. For direct-vent appliances, mechanical-vent heating appliances or domestic hot water equipment, where the bottom of the vent terminal and the air intake is installed below four feet above grade the following requirements must be satisfied:
  - A. If there is not one already present, on each floor level where there are bedroom(s), a carbon monoxide detector and alarm shall be placed in the living area outside the bedroom(s). The carbon monoxide detector shall comply with NFPA 720 (2005 Edition).
  - B. A carbon monoxide detector shall be located in the room that houses the appliance or equipment and shall:
    - Be powered by the same electrical circuit as the appliance or equipment such that only one service switch services both the appliance and the carbon monoxide detector;
    - Have battery back-up power;
    - Meet ANSI./UL 2034 Standards and comply with NFPA 720 (2005 Edition); and
    - Have been approved and listed by a Nationally Recognized Testing Laboratory as recognized under 527 CMR.
  - C. A Product-approved vent terminal must be used, and if applicable, a Product-approved air intake must be used. Installation shall be in strict compliance with the manufacturer's instructions. A copy of the installation instructions shall remain with the appliance or equipment at the completion of the installation.
  - D. A metal or plastic identification plate shall be mounted at the exterior of the building, four feet directly above the location of vent terminal. The plate shall be of sufficient size to be easily read from a distance of eight feet away, and read "Gas Vent Directly Below"
2. For direct-vent appliances, mechanical-vent heating appliances or domestic hot water equipment where the bottom of the vent terminal and the air intake is installed above four feet above grade the following requirements must be satisfied:
  - A. If there is not one already present, on each floor level where there are bedroom(s), a carbon monoxide detector and alarm shall be placed in the living area outside the bedroom(s). The carbon monoxide detector shall comply with NFPA 720 (2005 Edition).
  - B. A carbon monoxide detector shall:
    - Be located in the room that houses the appliance or equipment;
    - Be either hard-wired or battery powered or both; and
    - Shall comply with NFPA 720 (2005 Edition).

A Product-approved vent terminal must be used, and if applicable, a Product-approved air intake must be used. Installation shall be in strict compliance with the manufacturer instructions. A copy of the installation instructions shall remain with the appliance or equipment at the completion of the installation.

For the state of Massachusetts a **T-handle gas shut-off valve** must be used on a gas appliance. This T-handle gas shut-off valve must be listed and approved by the state of Massachusetts. This is in reference to the state of Massachusetts state code CMR238.

# Locating your Appliance

(above or below grade)  
**Installing with Top Vent**

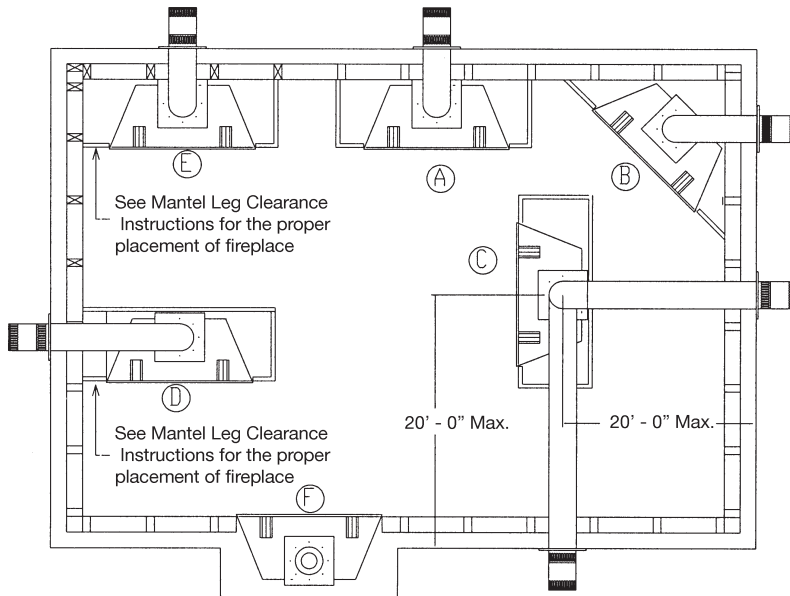

Island installation with a top vent is possible as long as the horizontal portion of the vent system does not exceed 20 feet (6.1m). When you install your fireplace as in position 'B', 'D' or 'E', a minimum of 6 inches (153mm) clearance must be maintained from the perpendicular wall and the front of the appliance.

## Fireplace Dimensions ZDV3320, ZDV6000 & MQRB3328 with Louvers

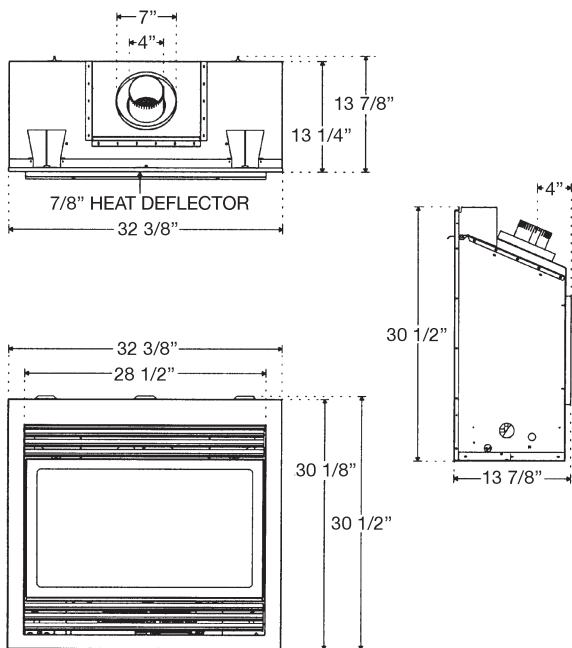

## Fireplace Dimensions ZDV3320, ZDV6000 & MQRB3328 with Clean View Kit

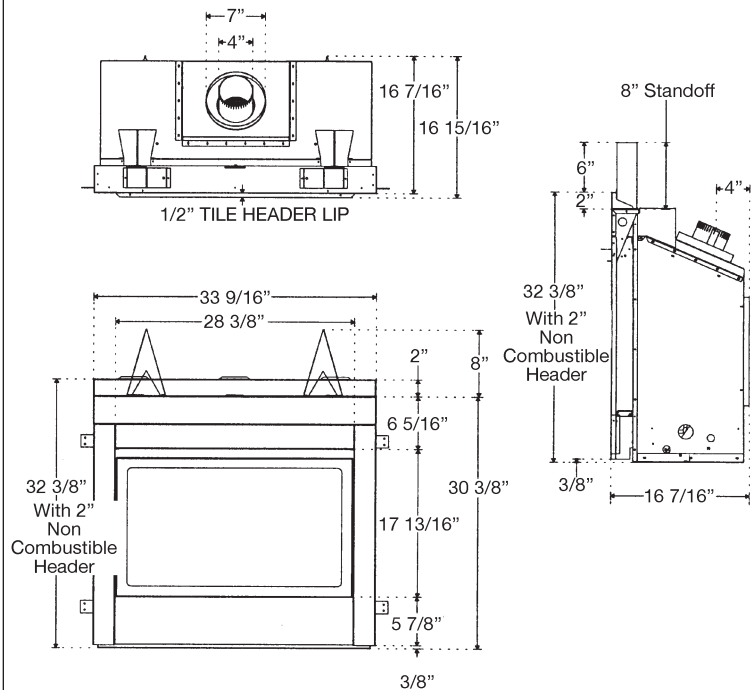

# Framing for your Gas Fireplace

## ZDV3320, ZDV6000 & MQRB3328 with Louvers

## ZDV3320, ZDV6000 & MQRB3328 with Clean View Kit

NOTE: LOW PROFILE ENCLOSURE 43" TO 60" MUST MAINTAIN A MINIMUM CLEARANCE OF 6" FROM TOP OF 7" FLEX PIPE TO BOTTOM OF ENCLOSURE TOP.

VERTICAL VENTING "MUST" MAINTAIN 1" CLEARANCES TO COMBUSTIBLES

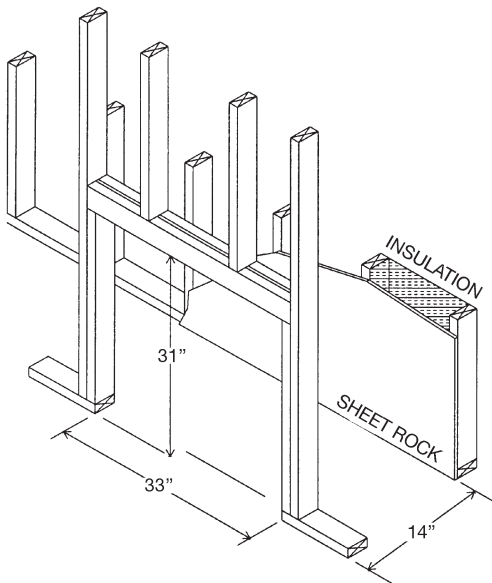
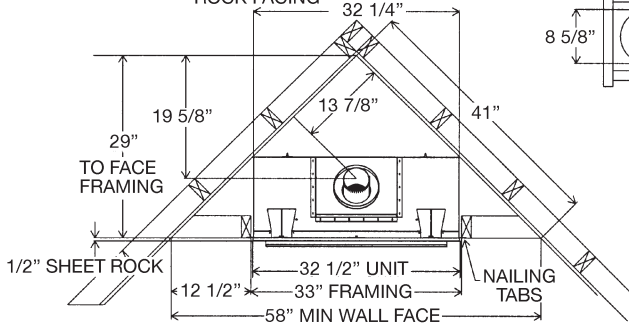
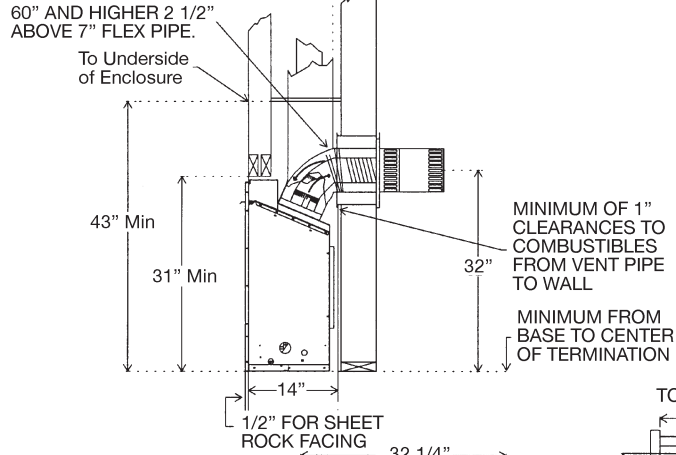

NOTE: LOW PROFILE ENCLOSURE 45" TO 55" MUST MAINTAIN A MINIMUM CLEARANCE OF 9" FROM TOP OF 7" FLEX PIPE TO BOTTOM OF ENCLOSURE TOP.

VERTICAL VENTING "MUST" MAINTAIN 1" CLEARANCES TO COMBUSTIBLES

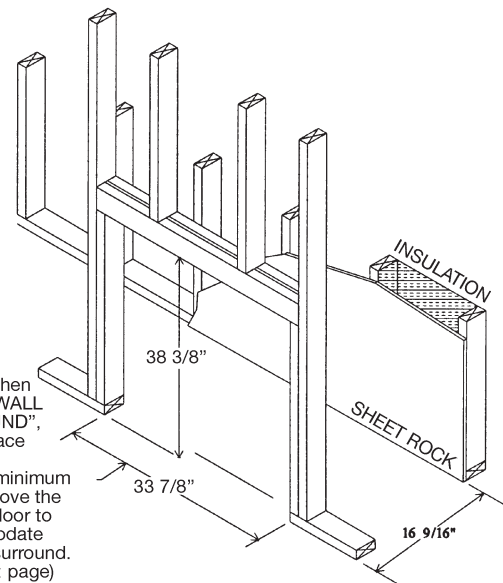
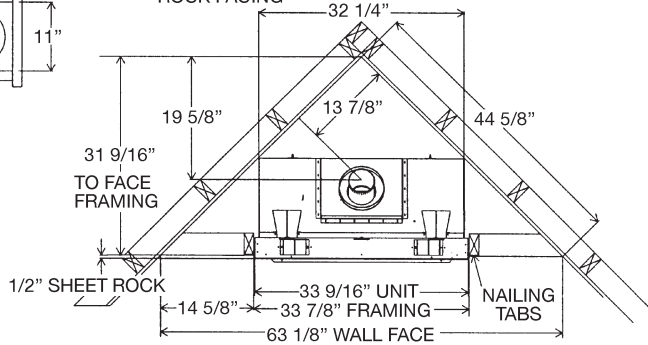
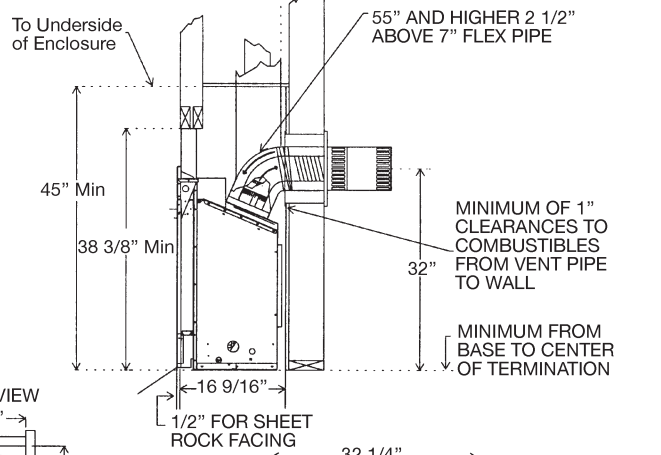

NOTE: When adding "WALL SURROUND", the fireplace must be raised a minimum 2 7/8" above the finished floor to accommodate the wall surround. (See next page)

**Note when using SIMPSON DURAVENT ADAPTER (ZDVDA) the fireplace clearances from the back standoff is one inch, thus increasing the framing depth to 15".**



## Framing for your Gas Fireplace

### Framing Specifications

1. Cold climate installation recommendation: When installing this fireplace against non insulated exterior wall or chase, it is recommended that the outer walls be insulated to conform to applicable insulation codes. Drywall should be installed over insulation to prevent contact of insulation and unit.
2. Choose fireplace location and frame in accordance with the fireplace framing dimensions specified (See Framing Diagrams). Bend nailing tabs forward on left and right of unit and place fireplace into framed enclosure. This allows for 1/2" in front of framing tabs for finishing materials.
3. Drywall or other material can extend flush with the appliance on the bottom, sides and top of fireplace.
4. When installing horizontal with a 90 degree bend maintain a minimum clearance above the bend as shown on page 12 (Clearance to Combustibles).
5. Hearth is not mandatory but is recommended for aesthetic purposes. Combustible floors cannot raise above the bottom of the fireplace. We recommend a non-combustible hearth projecting out 12" (305mm) or more in front of the fireplace.

**Note when using SIMPSON DURAVENT ADAPTER (ZDVDA) the fireplace clearances from the back standoff is one inch, thus increasing the framing depth to 15".**

For **Propane Horizontal Installations** the venting must be a minimum of one foot vertical off the flue before the elbow on any horizontal runs of one foot or greater. This allows for cleaner combustion and greatly reduces carboning and cleaning of glass. (Does not apply to Back Flue Models).

# Z33CVCK - Framing and Facing Requirements

## ZDV3320, ZDV6000 & MQRB3328 With Z33CVCK (CLEAN VIEW CIRCULATING KIT)

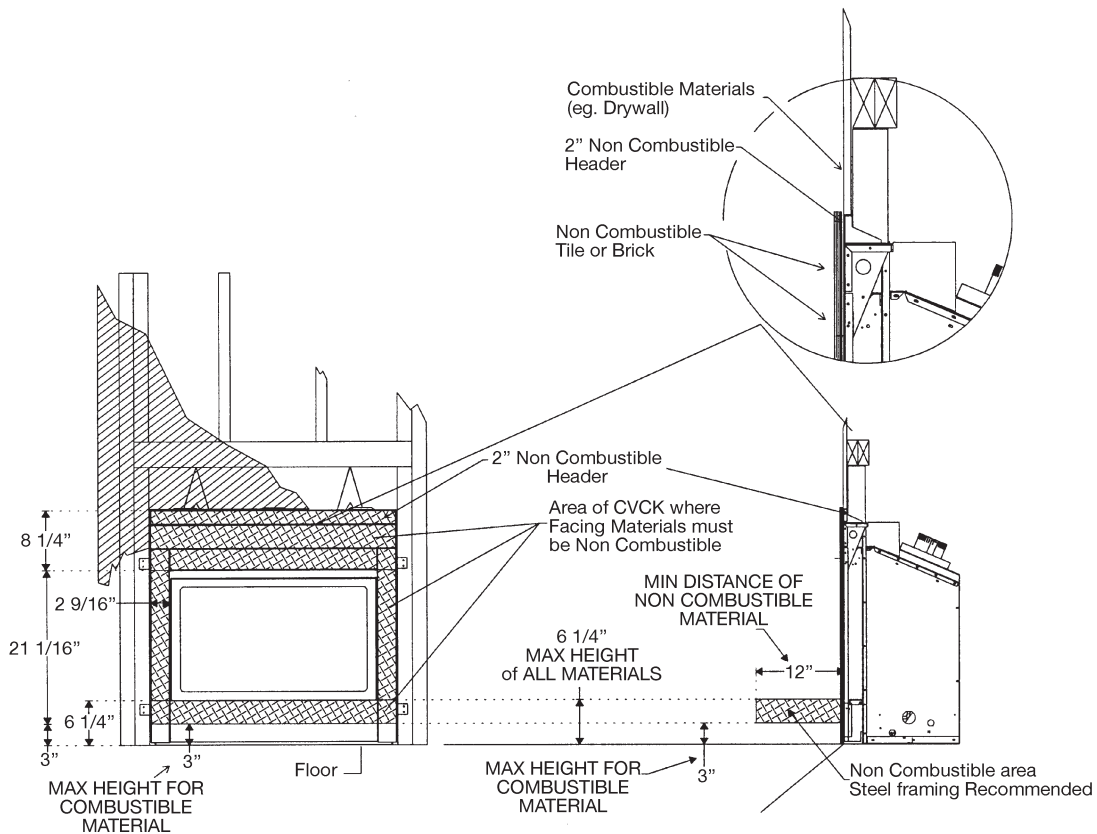

## Z33CVCK - with Wall Surround

**\*Note: A Z33CVCK Must be used When installing Wall Surround\***

\*Installation of Wall Surround on ZDV3320, ZDV6000, & MQRB3328 fireplace requires the fireplace to be installed at a minimum height of 2 7/8" from the bottom of fireplace to the finished floor. This will maintain a Min air gap of 3/8" from the bottom of Wall Surround to finished floor.

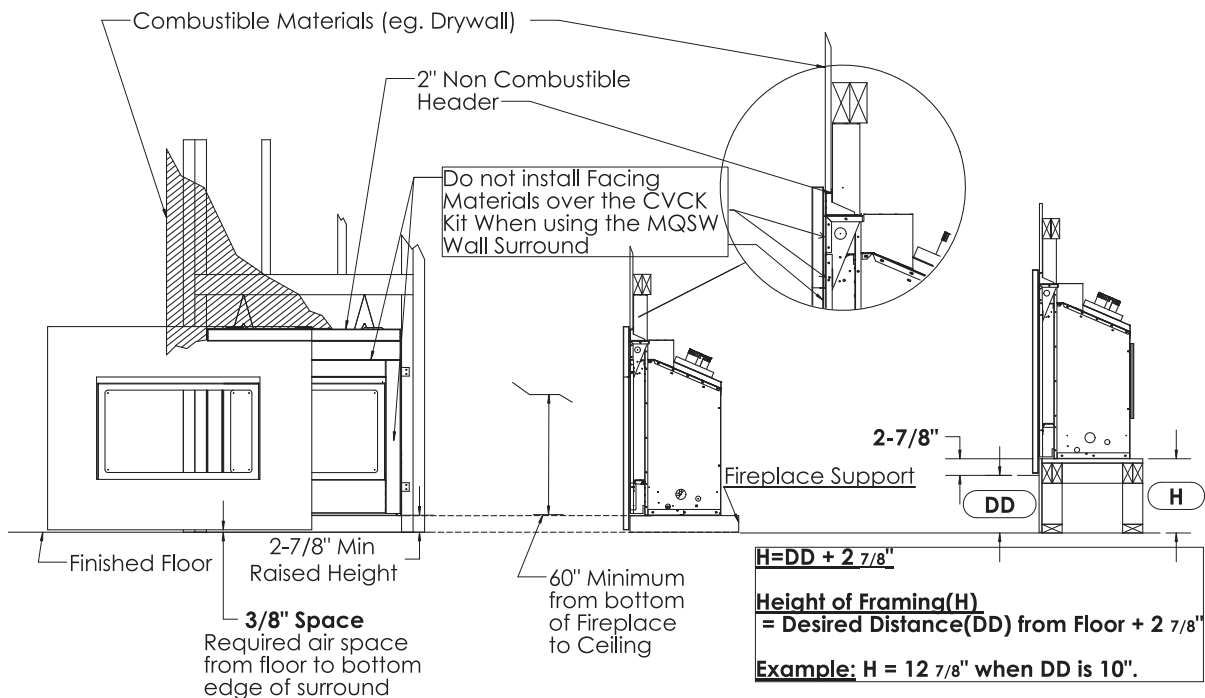

## HOW TO INSTALL CLEAN VIEW KIT (CVCK)

For ZDV3318/ZDV3622/ZDV6000/ZDV3320/MQRB3328/MQZDV3318/MQZDV3622



**WARNING:** Failure to position the parts in accordance with these diagrams or failure to use only parts specifically approved with this appliance may result in property damage or personal injury.

**CAUTION:** When using CVCK DO NOT INSTALL a Louver assembly.

1. Install optional fan kit (see Fan Instruction).
2. Fold two standoffs up into position and mount with supplied screws. (FIG 1) For ZDV6000/ ZDV3320/ MQRB3328 models use the larger (8") standoffs. On the ZDV3318 unit, remove the large 8" standoffs.
3. Hang CVCK on top of fireplace retainer tabs and rotate down into position. (FIG 2)
4. Using the screws provided, fasten the non-combustible header onto the top of the CVCK assembly.
5. Using four [4] supplied #6 screws, fasten CVCK kit to the inside frame of unit.
6. Using ten [10] supplied screws, install the top shield into the CVCK.
7. Kit is supplied with 2 valve extension knobs. Align the notches and slide the extensions onto valve knobs.
8. DO NOT brick or tile beyond the inside area of the CVCK kit to allow for removal of door.

**NOTE: ADDITIONAL ACCESS FOR GASLINE INSTALLATION AND FAN ELECTRICAL INSTALLATION!** When CVCK is installed in framing, remove the four [4] screws from the bottom panel. Once screws are removed, bottom panel can be removed to gas valve and fan system.

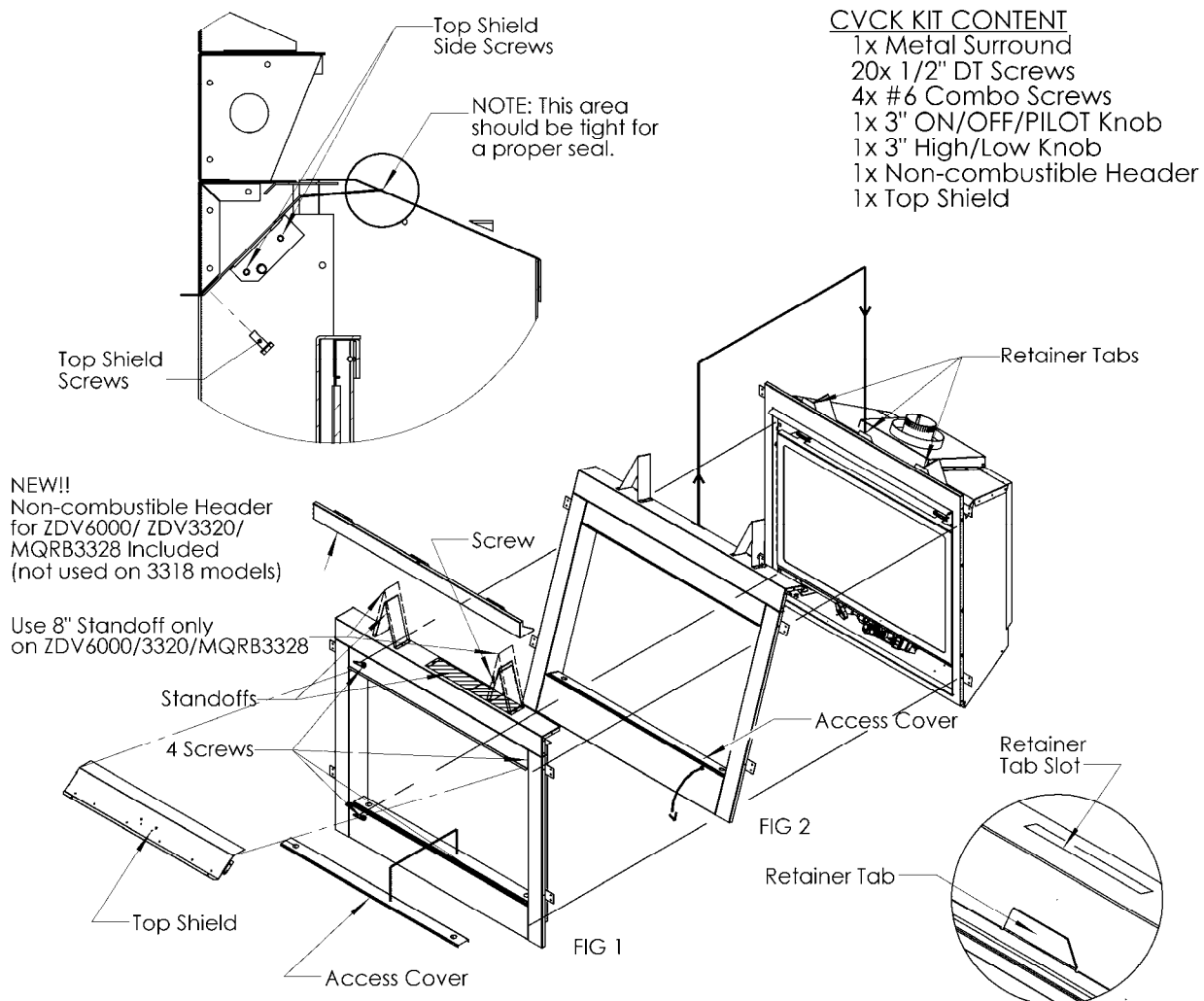

# CLEARANCES - ZDV3320/6000/MQRB3328 - Mantels & Surrounds

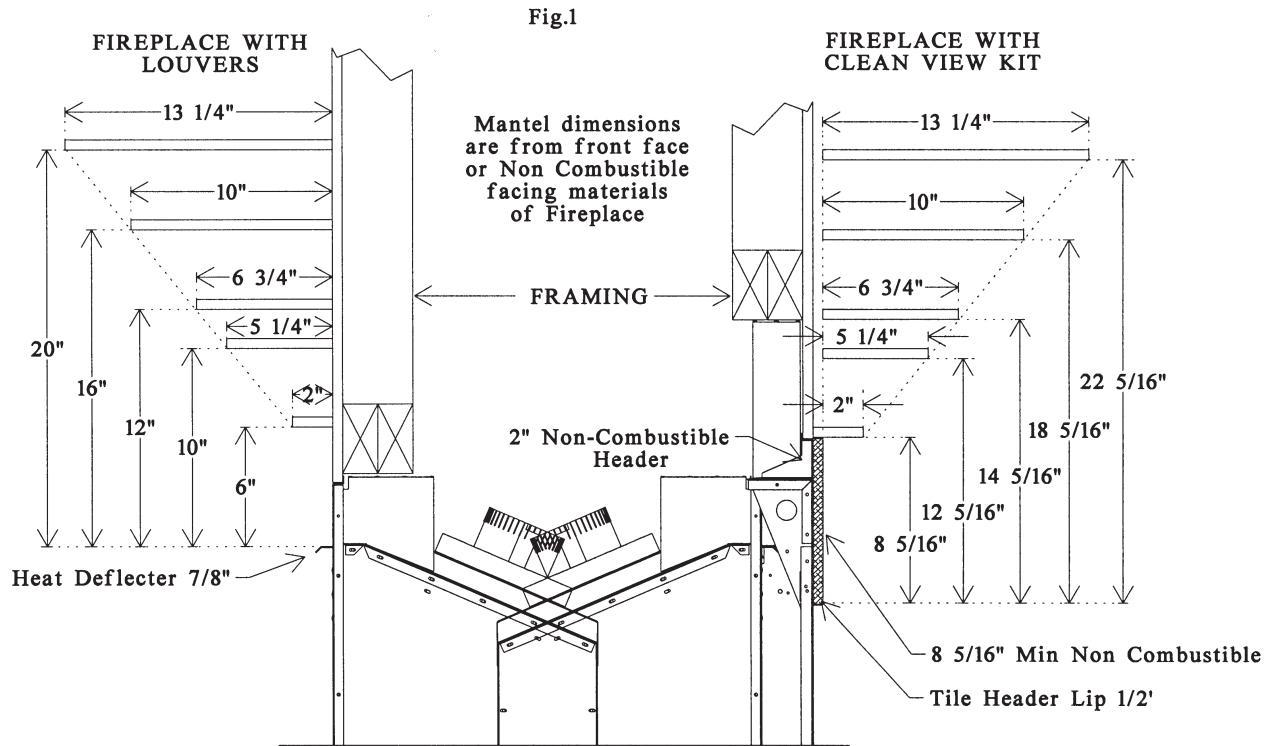

**! WARNING:** Combustible objects must not be placed on a non-combustible mantel unless the non-combustible mantel meets the minimum height and width requirements for a combustible mantel.

Fig.2 Fireplace with Clean View Kit and Wall Surround

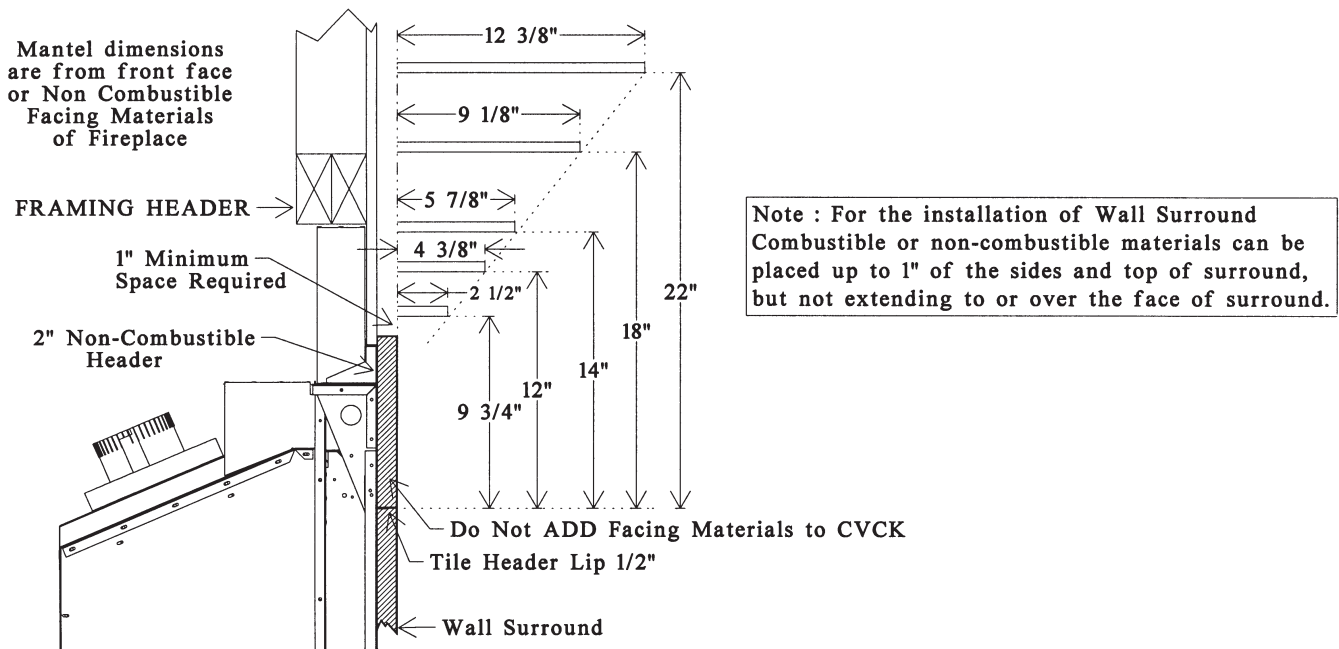

# ZDV3320/6000/MQRB3328 - Clearance to Combustibles

## Clearance to Combustibles

Back (from Standoffs)	0 inches/0 mm
Side (from standoffs)	0 inches/0 mm
Floor	0 inches/0 mm
Ceiling (from bottom of fireplace)	60 inches/150 cm
Top (from standoffs)	0 inches/0 mm
<b>Louvered Unit</b>	
Top of 90 degree bend in Minimum Enclosure of 43 to 60 inches	6 inches/152.5 mm / All Vent Systems
Enclosure over 60 inches	2 1/2 inches/38mm/All Vent Systems
<b>CVCK Unit (non louvered)</b>	
Top of 90 degree bend in Minimum Enclosure of 45 inches to 55 inches	9 inches/228.6 mm / All Vent Systems
Enclosure over 55 inches	2 1/2 inches/38mm All vent Systems
Top of Horizontal Pipe	1 1/2 inches/38 mm / All Vent Systems
Side & Bottom of Horizontal Pipe	1 inch/25.5mm / All Vent Systems
Vertical Vent Pipe	1 inch/25.5mm / Kingsman Vent Systems
Vertical Vent Pipe Systems	1 1/4 inch/32mm / Simpson/AmeriVent/Selkirk Direct Temp Systems

(NOTE -Floor) if installing the appliance directly on carpeting or other combustible materials other than wood flooring, the appliance shall be installed on a metal or wood panel, the full width and depth of the appliance. Carpet may extend 1 inch above the floor of appliance.

For units with CVCK (Clear View Circulating Kit) see framing with CVCK to establish floor heights

## Mantels

Depending on the depth of the fireplace mantel, it may be installed higher or lower from the top of the fireplace opening. See drawings for proper installation height of your combustible mantel. Non-combustible mantels may be installed at any height above the fireplace opening.

Non combustible materials such as brick, tile, etc. can extend up to or over the front face of the fireplace (NO PORTION OF GRILL AREA OR DOOR AREAS CAN BE COVERED).

Combustible material can extend flush to unit up to the top, bottom and sides of fireplace to stand-offs.

For COMBUSTIBLE materials extending in front of fireplace consult (Mantel and Mantel Leg Drawings).

Note when using SIMPSON DURAVENT ADAPTER (ZDVFDA) the fireplace clearances from the back standoff is one inch, thus increasing the framing depth to 15".

If slim line brass surround is used, brick, tiles or other NON-COMBUSTIBLE materials may extend past the front of unit giving a recessed appearance. For COMBUSTIBLE materials extending in front of fireplace consult (Mantel and Mantel Leg Drawings).

If wide brass surround is used finish materials must be flush with front of unit.

**Note: When using paint or lacquer to finish the mantel, such paint or lacquer must be heat resistant (250° F) to prevent discoloration.**



**WARNING: Combustible objects must not be placed on a non-combustible mantle unless the non-combustible mantle meets the minimum height and width requirements for a combustible mantle.**

## Side Walls

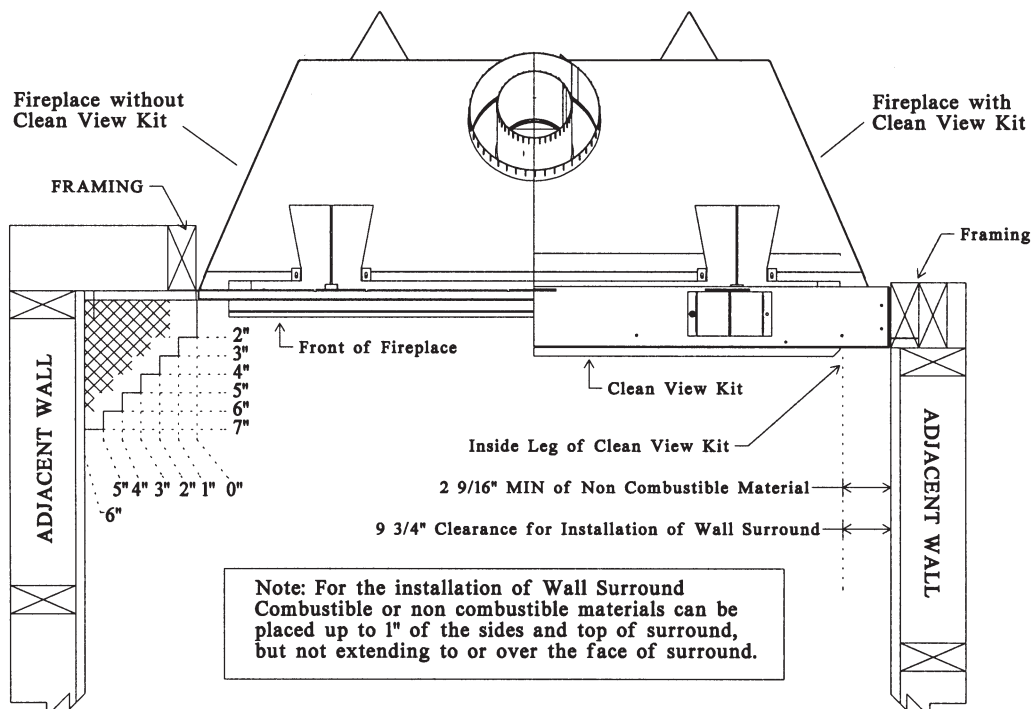

Note: For the installation of Wall Surround Combustible or non combustible materials can be placed up to 1" of the sides and top of surround, but not extending to or over the face of surround.

## MQ33SW Wall Mount Surround Dimensions

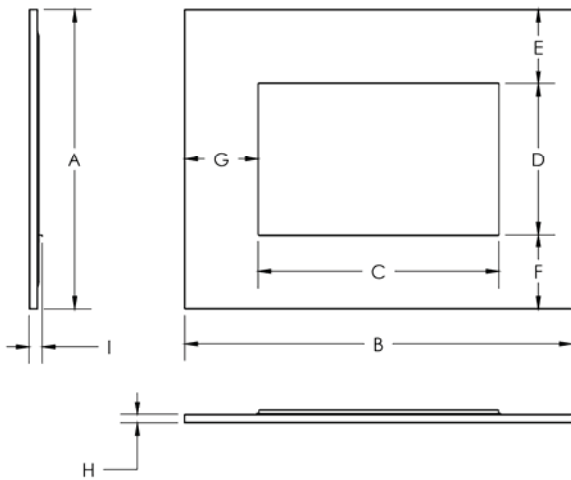

### MQ33SWF

<b>A</b>	35-5/16"
<b>B</b>	45-13/16"
<b>C</b>	28-3/8"
<b>D</b>	17-13/16"
<b>E</b>	8-3/4"
<b>F</b>	8-3/4"
<b>G</b>	8-3/4"
<b>H</b>	1"
<b>I</b>	1-3/16"

## Installation of MQ33SW Wall Mount Surround

- Parts List**  
 - Modern Surround  
 - 2x Mounting Screws
- Tools Required**  
 - Phillips Head Screwdriver

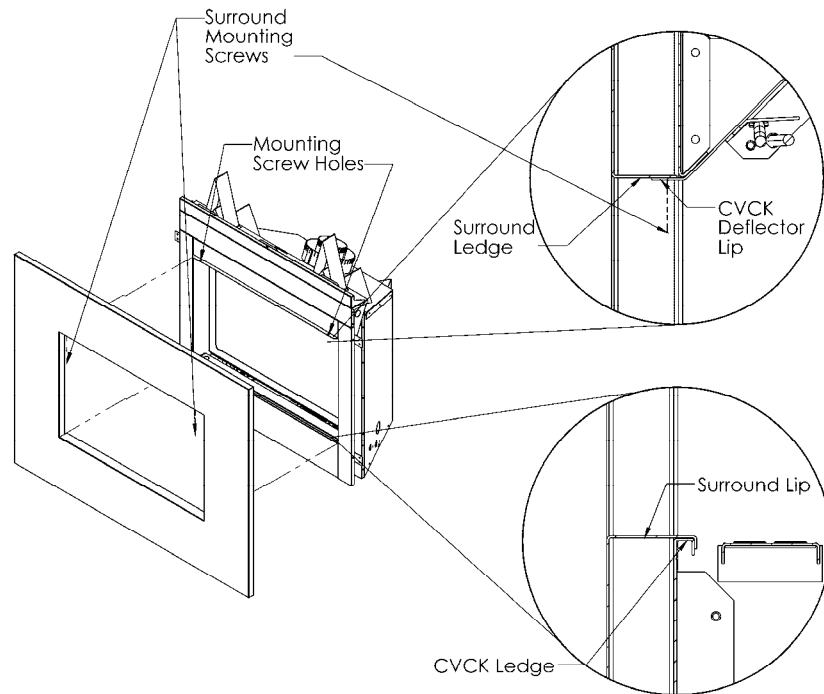

1. Set Surround Lip on CVCK Ledge and ensure that it is securely in place.
2. Swing the upper portion of the Surround so that the Surround Ledge is resting on top of the CVCK Deflector Lip.
3. Align the Mounting Screw Holes and fasten the Surround in place with the supplied screws.
4. Attach optional decorative bands as desire.
5. To remove, simply reverse these steps.

# Fan Kit Installation

## Fan installation Instructions for ZDV6000/3320/3318/3318MQ with or without CVCK (Clean View Circulating Kit).

**Note:** Install Fan Kit Before Installing optional CVCK (Clean View Circulating Kit).

If CVCK has been installed into framing additional access is provided by removing screws from bottom panel of CVCK. See **Installing Clean View Kit (CVCK)**.

- Slide fan housing into unit and place over 2 Fan Retainer Tabs. Tabs are pre punched and bent up (**\*Note: on 6000/3320 units, these Tabs are located on the right side of the unit**). Rubber grommets at the base of the fan should fit snugly over the tabs.
- For Fan Disc Installation these units have been installed with a sliding track system. Install the Thermodisc provided with the Fan Kit. Place Thermodisc into sliding assembly (**Fig.1**), and attach 2 leads exiting right side of the fan housing into thermodisc. Now slide disc assembly on track to lock into position. To service disc simply pull swivel handle slide towards you while rotating handle to access disc.

**Caution:** Label all wires prior to disconnection when servicing controls. Wiring errors can cause improper and dangerous operation. Verify proper operation after servicing.

### Parts List:

- 1ea. Fan comes with 4ft cord. Two 14" leads (female ends)
- 1ea. Variable speed control (wall mount type)
- 1ea. Thermodisc
- 1 Thermodisc mount assembly

- Wire Junction Box and wall mounted variable speed control to 120v. Install a duplex outlet to junction box and plug fan into outlet.
- Turn the wall switch on (clockwise). Turn fireplace on. Once the sensor in the unit reaches operating temperature (approximately 10 to 15 minutes) the fan will turn on. The fan can be switched off if desired by turning the wall switch fully counter clockwise.
- To set the minimum fan speed, remove the variable switch from the wall mount. Turn the variable speed wall controller to its minimum setting (fully counterclockwise). Use the set screw on the side of the variable speed controller to increase or decrease the minimum fan speed (lowering the minimum fan speed will decrease sound level created by fan). Reinstall switch into wall mount and cover with face plate.

**Note:** To service fan with CVCK Kit installed see Removing Burner System in manual. If CVCK is finished with a MQSW Wall Surround the MQSW may be removed by removing the 4 attachment screws and removing the MQSW allowing access into the bottom of the fireplace to service blower.

### Electrical Services

All optional Fan Kits are equipped with a 120V, 60Hz, .4amp blower. Note: All electric connections are to be made in accordance with CSA Standard C22.1 – Canadian Electrical Code part I or with the National Electrical Code, ANSI/NFPA 70 (latest edition) and /or in accordance with local codes.

**WARNING: Electrical Grounding Instructions.**  
This appliance is equipped with a three-pronged (grounding) plug for your protection against shock hazard and should be plugged directly into a properly grounded three-prong receptacle. Do not cut or remove the grounding prong from this plug.

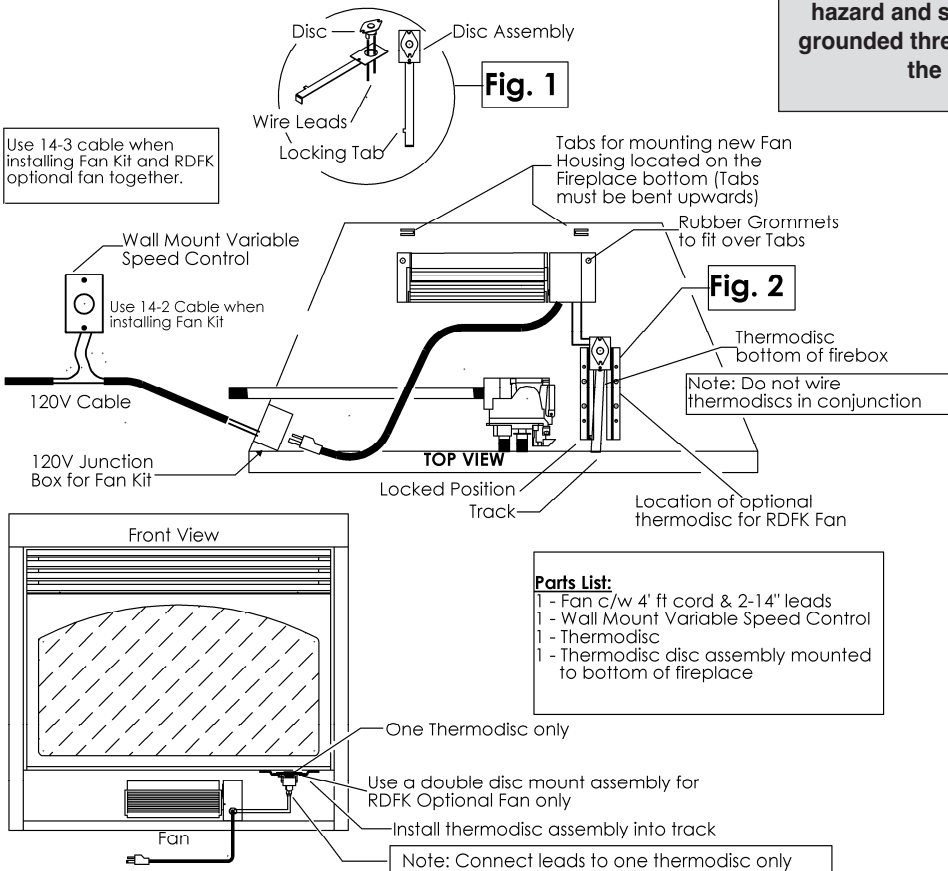

### Parts List:

- 1 - Fan c/w 4' ft cord & 2-14" leads
- 1 - Wall Mount Variable Speed Control
- 1 - Thermodisc
- 1 - Thermodisc disc assembly mounted to bottom of fireplace

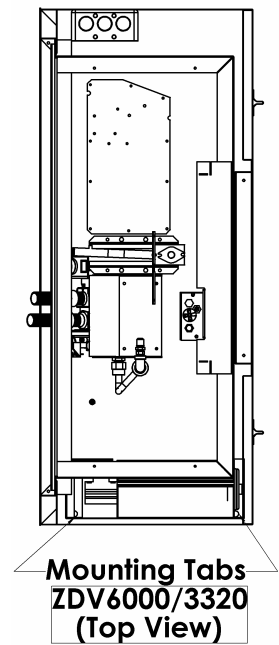

**CAUTION: DO NOT ATTACH 120V FAN ASSEMBLY TO MILLIVOLT GAS VALVE SYSTEM**

## Installing Brick Panel for Model ZDV3320/6000

1. Remove the glass door.
2. Slightly tilt the Rear Brick panel forward and set it against the rear of fireplace.
3. Loosen screws holding brick clips in position. Rotate clips up and out of the way. Slightly tilt the Side Brick panel sideways as you're sliding it in, and set it against the side of the firebox. Ensure that it is pushed back far enough to pin the Rear Brick panel in place. Repeat this procedure for both side panels.
4. Rotate the Brick Clip down to hold the Side Brick panels in place and tighten the Brick Clip screws.

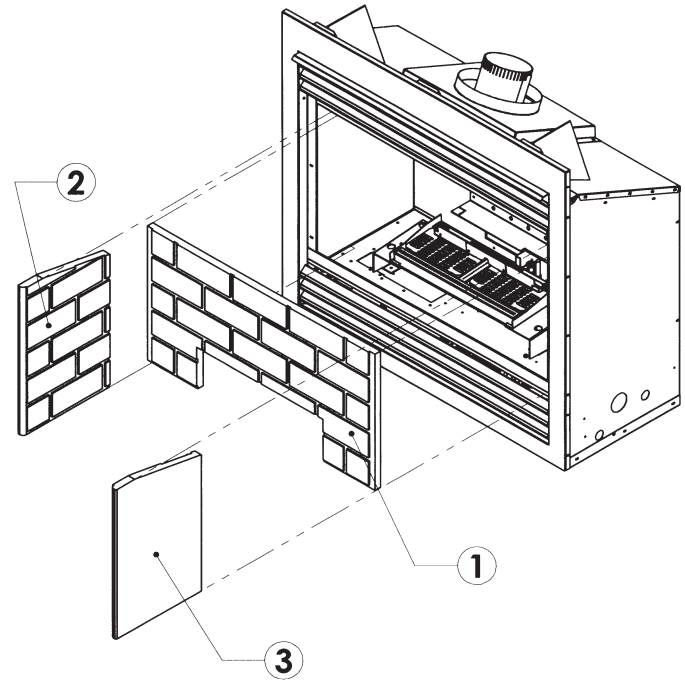

## Installing Porcelain Panel for Model ZDV3320/6000

1. Remove the glass door.
2. Slightly tilt the Rear Porcelain panel forward and set it against the rear of firebox.
3. Remove the Brick Clips and keep the screws for Porcelain Panel installation.
4. Slightly tilt the Side Porcelain panel sideways as you're sliding it in, and set it against the side of the firebox. Ensure that it is pushed back far enough to pin the Rear Porcelain panel in place. Repeat this procedure for both side panels.
5. Using the Brick Clip screws, fasten the side panels in place.

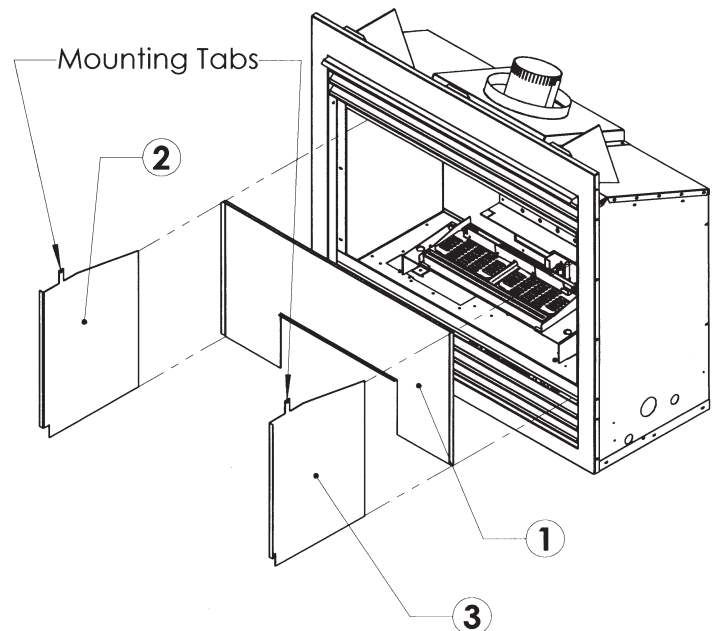



# Installing MQRB3328 Liner Panels

**There are several types of Liner Panels available for the MQRB3328:**

- Flat Black Back Panel and False Bottom- (Supplied with Unit).
- Porcelain False Bottom- **MQRB33PB**
- Porcelain Back and Side Panels- **MQRB33PL**

## Removal of Back Panel and False Bottom

1. Remove the Door from the fireplace by unlatching the 2 latches on top of the unit.
2. Lift the False Bottom out of the Firebox. (**Note: If Side Panels are Not used, skip to step 6.**)
3. The Back Panel is held in place by the False Bottom and 2 Locking Tabs on the inside top of the Firebox (See **Ref.1** Below). Once the False Bottom is removed, bend the Locking Tabs up and out of the way so that the Back Panel can be tilted forward and removed from the Firebox.

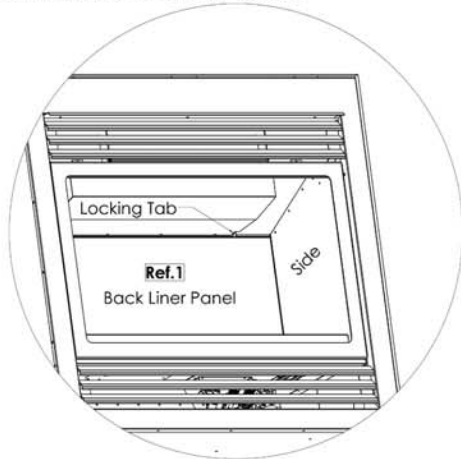

**MQRB3328 Base Model**

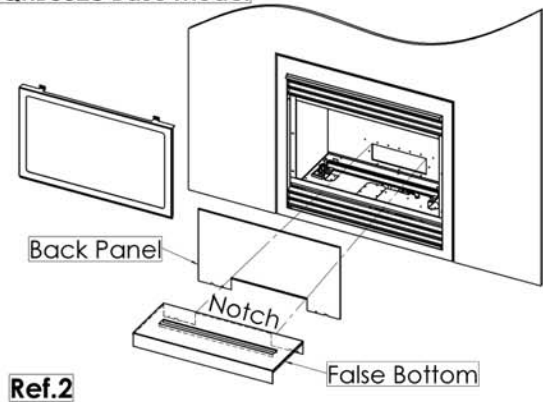

## Installation of New MQRB3328 Liner Panels.

4. Place new Back Panel up against the rear of the Firebox by placing the notched edge over the Burner System and tilting the top back into place. Bend the 2 Locking Tabs on the inside top of the Firebox downward (See **Ref.1** above).
5. Remove the 2 DT Screws from the Firebox sides (Do not discard these screws). Place Side Panels into Firebox as shown in **Ref.3** below; tilt and slide into place. Insert and tighten a DT screw in the top of the Side Panel and into the side of the Firebox.
6. Carefully place False Bottom over the burner system at the bottom of the Firebox. Make sure the notched side of the False Bottom is at the back side of the Firebox as shown in **Ref. 2** above, or the fireplace will not operate properly. Replace the Door.

**MQRB3328 Liner Panel Installation**

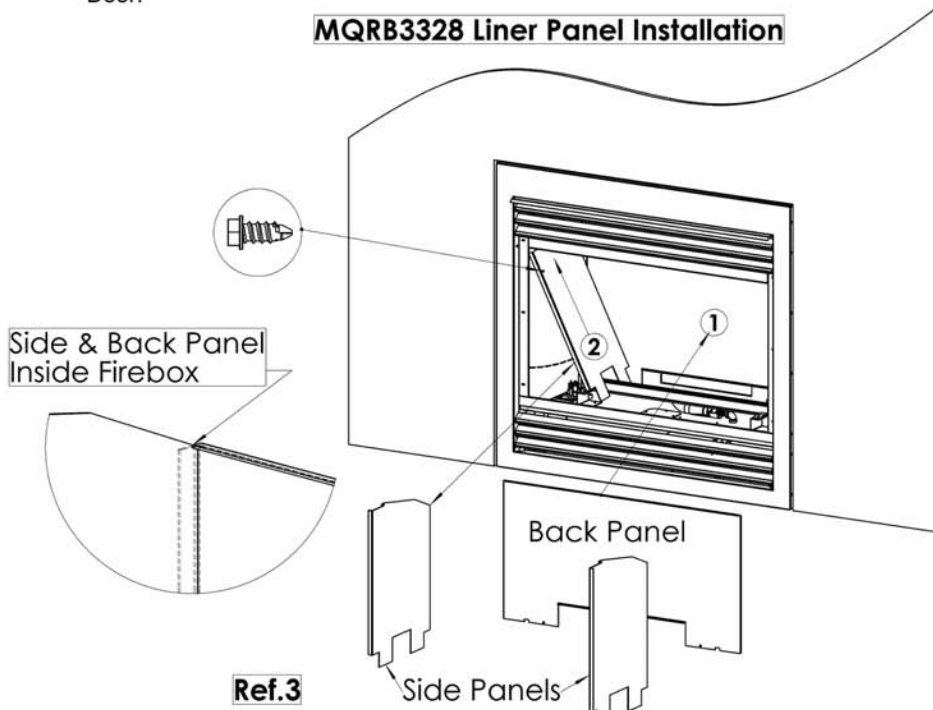

**Parts List for MQRB33PL/SL:**

- 1 Left Side Panel
- 1 Right Side Panel
- 1 Back Panel
- 2 DT Screws

**Parts List for MQRB33PB/SB:**

- 1 False Bottom

## Gas Line Installation

This gas appliance should be installed by a qualified installer in accordance with local building codes and with current CAN/CGA - B149.1 or .2 installation codes for Gas Burning appliances and equipment in Canada and the National Fuel Gas Code ANSI Z223 in the U.S.A.

1. The gas pipeline can be brought in through either the right or the left side of the appliance. A knockout is provided at either location to allow for the gas pipe installation and testing of any gas connection.
2. The gas control inlet is 3/8" NPT. Typical installation layout for rigid pipe is shown at right.
3. When using **copper** or **flex connector**, use only approved fittings. Always provide a union so that gas line can be easily disconnected for burner or fan servicing. See gas specification for pressure details and ratings.
4. When a vertical section of gas pipe is required for the installation, a condensation trap is needed. See CAN/CGA-B149.1 or .2 for code details.
5. For natural gas, a minimum of 3/8" iron pipe with gas minimum pressure of 4.5 w.c. must be used for supply from the gas meter. Consult with the local gas utility if any questions arise concerning pipe sizes.
6. A 1/8" NPT plugged tapings are accessible for test gauge connection both on the inlet and outlet of the gas valve.
7. Turn the gas supply ON and check for leaks. **DO NOT USE OPEN FLAME FOR THIS PURPOSE.** Use an approved leak testing solution.
8. The appliance and its individual shutoff valve must be disconnected from the gas supply piping system during any pressure testing of that system at test pressures in excess of 1/2 PSIG (3.5 KPa).
9. The appliance must be isolated from the gas supply piping system by closing its individual shutoff valve during any pressure testing of the gas supply piping system at test pressures equal to or less than 1/2 PSIG (3.5 KPa).

**Note: The gas line connection may be made of 1/2" rigid pipe or an approved flex connector. Since some municipalities have additional local codes, it is always best to consult your local authorities and the current CAN/CGA - B149.1 or .2 installation code in Canada or the National Fuel Gas code ANSI Z223.1 in the U.S.A.**

For the state of Massachusetts a **T-handle gas shut-off valve** must be used on a gas appliance. This T-handle gas shut-off valve must be listed and approved by the state of Massachusetts. This is in reference to the state of Massachusetts state code CMR238.

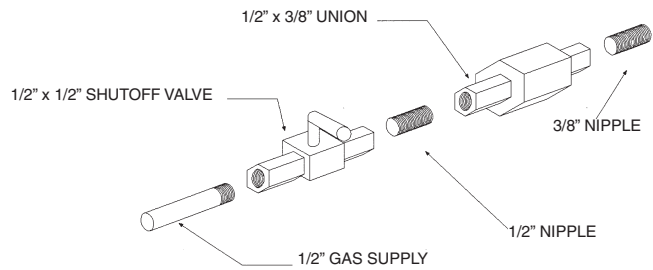

**Important: Always check for gas leaks with a soap and water solution. Do not use open flame for leak testing.**

## Gas Specifications

Model	Fuel	Gas Control	Maximum Input
ZDV6000N	Natural Gas	Millivolt	25,000 BTU Hi
		(Adjustable)	21,000 BTU Lo
ZDV6000LP	Propane	Millivolt	25,000 BTU Hi
		(Adjustable)	20,000 BTU Lo
ZDV3320N	Natural Gas	Millivolt	21,000 BTU Hi
		(Adjustable)	15,000 BTU Lo
ZDV3320LP	Propane	Millivolt	21,000 BTU Hi
		(Adjustable)	15,000 BTU Lo
MQRBZDV3328N	Natural Gas	Millivolt	25,000 BTU Hi
		(Adjustable)	17,000 BTU Lo
MQRBZDV3328LP	Propane	Millivolt	25,000 BTU Hi
		(Adjustable)	20,000 BTU Lo
MQRBZDV3328NT	Natural Gas	Millivolt	21,000 BTU Hi
		(Adjustable)	15,000 BTU Lo
MQRBZDV3328LPT	Propane	Millivolt	22,500 BTU Hi
		(Adjustable)	17,500 BTU Lo

Gas Inlet SIT or Robertshaw			3/8" NPT
Gas Supply Pressure	Minimum	Normal	Maximum (in w.c.)
Natural Gas	5.5	7.0	9.0
Propane	10.8	11.0	12.0
Manifold Pressure	Natural Gas	3.5 in. w.c.	
	Propane	10.5 in. w.c.	
Orifice Size:	#40	NG (0-4500ft)	Primary Air: 3/16"
ZDV6000	#52	LP (0-4500ft)	Primary Air: 7/16"
Orifice Size:	#43	NG (0-4500ft)	Primary Air: 1/16"
ZDV3320	#53	LP (0-4500ft)	Primary Air: Fully Opened
Orifice Size:	#40	NG (0-4500ft)	Primary Air: 1/16"
MQRB3328	#52	LP (0-4500ft)	Primary Air: 5/16"
Orifice Size:	#44	NG (0-4500ft)	Primary Air: 1/16"
MQRB3328T	#53	LP (0-4500ft)	Primary Air: 5/16"

## General Glass Information

### Glass Cleaning

It will be necessary to clean the glass periodically. During start-up, condensation, which is normal, forms on the inside of the glass and causes dust, lint etc. to cling to the glass surface. Also, initial paint curing can deposit a slight film on the glass. It is therefore recommended that initially the glass be cleaned two or three times with non-abrasive common household glass cleansers and warm water. After that, the glass should be cleaned two or three times a season depending on the circumstances.



### Warning and Cautions.

- Do not clean when the glass is hot.
- Do not use abrasive cleaners.
- Using a substitute glass will void all product warranties.
- Do not strike or abuse glass. Care must be taken to avoid breakage of the glass.
- Do not operate this fireplace without the glass front or with a broken glass.

### Glass Replacement

#### REPLACEMENT GLASS FOR BOTH DIRECT VENT UNITS

Only Robax ceramic or coated Neoceram glass may be used for Model ZDV6000 & MQRB3328. Either tempered or ceramic glass may be used for Model ZDV3320 & MQRB3328T. Must be minimum 5mm thick.

#### Removal of the Glass Door

1. Unfasten the two latches located behind upper grill.
2. To remove, pull frame forward and lift from bottom door retainer.
3. To replace glass, clean all materials from door frame. Using a high heat silicone (temperature-resistant to 500°F (260°C)) apply a bead of approximately 1/32" to all four sides of frame and insert glass with new gasket. Frame should be on flat surface, with a small amount of weight pressing glass into silicone. Let dry approximately 15 to 20 minutes. The door can be re-installed by reversing Steps 1 & 2.

# Millivolt System, Lighting, & Burner Control

## FOR YOUR SAFETY READ BEFORE LIGHTING

**WARNING: If you do not follow these instructions exactly, a fire or explosion may result causing property damage, personal injury or loss of life.**

### BEFORE LIGHTING

- A** This appliance has a pilot which must be lighted by hand. When lighting the pilot, follow these instructions exactly.
- B** Smell all around the appliance area for gas. Be sure to smell next to the floor because some gas is heavier than air and will settle on the floor.

#### WHAT TO DO IF YOU SMELL GAS

- Do not try to light an appliance.
- Do not touch any electrical switch; do not use any phone in your building.
- Immediately call your gas supplier from a neighbour's phone. Follow the gas supplier's instructions.

- If you cannot reach your gas supplier, call the fire department.
- C** Use only your hand to push or turn the gas control knob. Never use tools. If the knob will not push in or turn by hand, don't try to repair it, call a qualified technician. Force or attempted repair may result in a fire or explosion.
- D** Do not use this appliance if any part has been under water. Immediately call a qualified service technician to inspect the appliance and to replace any part of the control system which has been under water.

## LIGHTING INSTRUCTIONS

- Stop! Read the safety information above on this label.
- Set the thermostat to lowest setting.
- Turn off all electrical power to the appliance.
- Locate valve under the burner assembly.
- If the control knob is not already in the off position, ie. the word "OFF" in the 9 o'clock position, then push in the gas control knob slightly and turn clockwise to "OFF".  
NOTE: Knob cannot be turned from "PILOT" to "OFF" unless knob is pushed in slightly. Do not use force.
- Wait five (5) minutes to clear out any gas. If you then smell gas. STOP! Follow "B" in the safety information above on this label. If you don't smell gas then go to the next step.
- Now push in the control knob slightly and turn counter-clockwise to the "PILOT" position.
- Push in the control knob all the way and hold it. With the other hand push in the red ignitor button until you hear a click. Now observe closely the pilot burner located on the rear center-left hand side of the main burner. If a flame has appeared then continue to depress the control knob for 20 seconds. If the flame did not appear then continue to depress the red ignitor button every 5 seconds until a flame is established. NOTE: If after 30 seconds a flame has not yet been established then turn the control knob back to the off position and repeat steps 5, 6 & 7.
- Once the pilot has been established hold the control knob in the depressed position for approximately 25 seconds before releasing. If the flame goes out then repeat steps 7 and 8.
- Now turn the control knob to the "ON" position. The burner will not light unless the wall switch thermostat or remote control is turned "ON" or in the case of the thermostat there is a call for heat.
- Close the access door and turn all electric power back to the appliance.

## TO TURN OFF THE APPLIANCE

- Set the thermostat to lowest setting.
- Turn off all electric power to the appliance if service is to be performed.
- Open the control access door.
- Push in the gas control knob slightly and turn clockwise to the "OFF" position. Do not force.
- Replace control access panel.

### Recommended Maximum Lead Length (Double Wire) When Using Wall Switch or Thermostat

Wire Size	Max. Length
14 GA.	100 FT.
16 GA.	64 FT.
18 GA.	40 FT.
20 GA.	25 FT.
22 GA.	16 FT.

#### Pilot Burner Adjustment

- Adjust pilot screw to provide proper sized flame.

**CAUTION: DO NOT WIRE 120 VOLT POWER TO MILLIVOLT SWITCHES OR THERMOSTAT.**

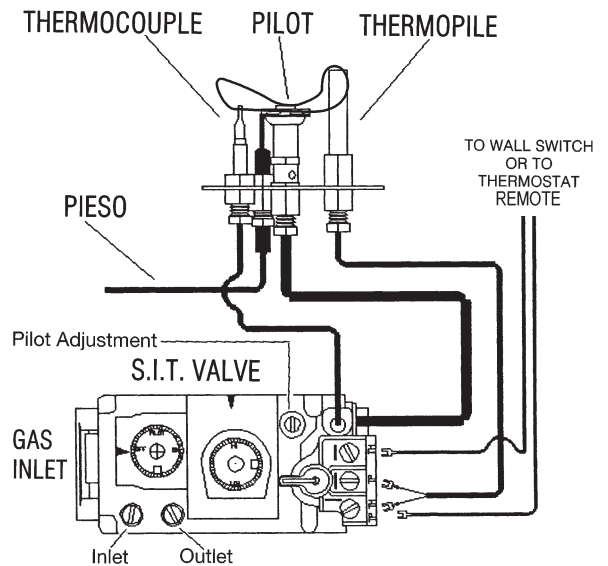

## Gas Conversion - ZDV3320/ZDV6000



**Warning:** This conversion kit shall be installed by a qualified service agency in accordance with the manufacturer's instructions and all applicable codes and requirements of the authority having jurisdiction. If the information in these instructions is not followed exactly a fire, explosion or production of carbon monoxide may result causing property damage, personal injury or loss of life. The qualified service agency is responsible for the proper installation of this kit. The installation is not proper and complete until the operation of the converted appliance is checked as specified in the manufacturer's instructions supplied with kit.

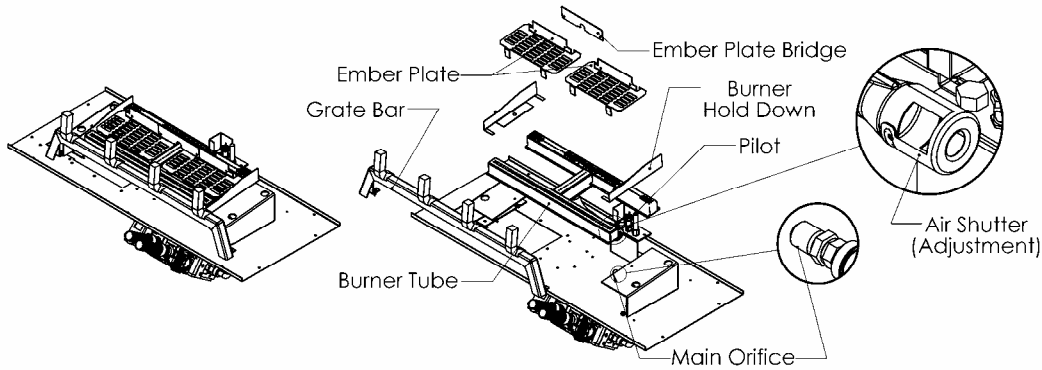

1. Remove ember plates right and left of burner, ember plates are held in place by 2 screws each.
2. Loosen screws from burner retainer tabs and slide burner to the left to remove from orifice.
3. Remove main orifice using a 1/2" wrench and replace with new conversion orifice. (See page 18.)
4. Install new pilot orifice (see next page) and Hi/Lo valve regulator by following instructions supplied with conversion kit.
5. Adjust the primary air setting to the correct setting as specified in the manual or label plate. To adjust air setting, loosen screw on the side of air mixing tube and rotate to the correct opening using a drill bit or tape measure. Retighten screw.
6. Reinstall ember plates and burner by reversing steps 1 & 2.

## Gas Conversion - MORB3328

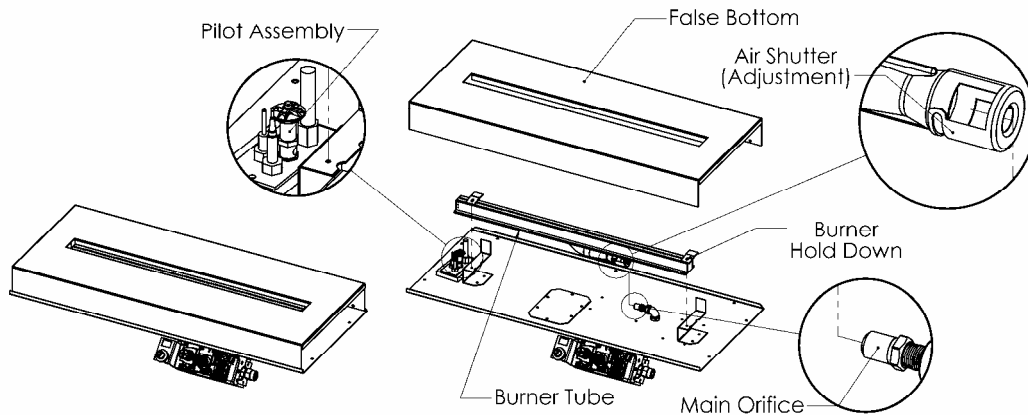

1. Remove false bottom and loosen the two [2] burner hold downs.
2. Slide the burner tube towards the left to remove from orifice.
3. Remove main orifice using a 1/2" wrench and replace with new conversion orifice. (See page 18.)
4. Install new pilot orifice (see next page) and Hi/Lo valve regulator by following instructions supplied with conversion kit.
5. Adjust the primary air setting to the correct setting as specified in the manual or label plate. To adjust air setting, loosen screw on the side of air mixing tube and rotate to the correct opening using a drill bit or tape measure. Retighten screw.
6. Reinstall ember plates and burner by reversing steps 1 & 2.

## Section B - Installation Instructions

### Gas Conversion Kit for Top Convertible Pilot - Series 091065X

Instructions for converting SIT 190 series pilot burner injection from NG to LPG and from NG to LPG On This information should be considered as supplemental to the Appliance Manufacturer's Instructions.



#### WARNING!

The installation of this conversion kit must only be undertaken by a qualified and certified gas appliance installer.

- 1 Shut off the gas supply to the appliance.
- 2 Allow the pilot burner to cool to room temperature.  
**WARNING: Touching a hot pilot burner can result in injury.**
- 3 The pilot hood is held in place by spring pressure. Remove the hood by pulling it directly up from the pilot bracket (1).
- 4 Insert a 5/32" or 4mm Allen wrench into the hexagonal key-way of the injector (2), and rotate it counter clockwise until it is free of the injector journal (3).
- 5 Verify that the new injector is proper for the application. The injector size is stamped on the side of the injector near the top. LPG injectors have a groove machined around their circumference near the top, while NG injectors do not have a groove (5). Refer to the Appliance Manufacturers instruction sheet for the proper injector size.
- 6 Insert the Allen wrench into the end of the injector. Then, insert into injector journal, and rotate the injector clockwise until a torque of 9 in-lbs. is achieved.
- 7 Replace the pilot hood by aligning the tab on the base of the hood with the slot in the side of the pilot journal, and push the hood down, directly onto the pilot bracket (4). The hood must sit squarely on the bracket for proper operation. Check to insure that the hood is properly seated onto the pilot bracket.



Fig. 1



Fig. 2



Fig. 3

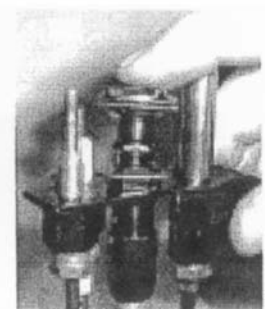

Fig. 4

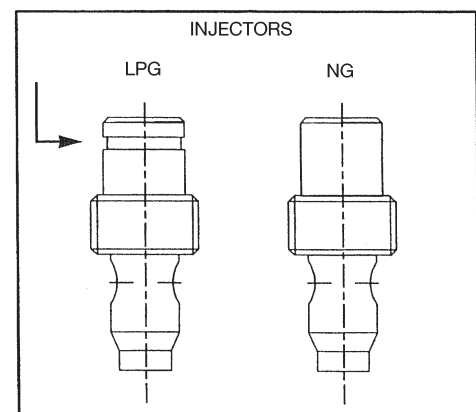

Fig. 5

#### WARNING!

This conversion kit must only be applied as part of a conversion kit supplied by the appliance Manufacturer for the specific appliance, and type of gas being converted.

**INSTALLER NOTICE.** These instructions must be left with appliance.

# IPI Electronic Ignition System

## Overview

The IPI system is an advanced burner controller that provides you with the option of having either a Standing-Pilot, or an intermittent igniting system. This alternating mode is controlled by the CPI/IPI Switch (Continuous Pilot Ignition/Intermittent Pilot Ignition) located on the IPI System Box. The difference between a Standing-Pilot and an Intermittent-Pilot is in whether the pilot stays lit or shuts off:

In Standing-Pilot, the pilot assembly is lit by the IPI Main Module and continues to stay lit until 1) the CPI/IPI Switch is switched to the IPI position; 2) a loss of electrical power (battery and AC source), 3) the flame sensor loses its signal, 4) the fuel supply discontinues, or 5) the IPI Main Module malfunctions.

In the Intermittent-Pilot mode, the pilot shuts off when the appliance is not in use. The advantage of this mode is that fuel is not consumed when the fireplace is not operating.

NOTE: In some jurisdiction, Intermittent-Pilot is required. That means the pilot cannot remain lit when the appliance is not operating.

## Components

The core of the IPI system is the Main Module and the IPI Valve. With these two components the system is able to operate a gas fireplace. There are also other components available to complement the IPI system.

**IPI System Cover:** Is essential in keeping the components at their proper operating temperatures. **DO NOT OPERATE THE APPLIANCE WITHOUT THIS COVER.**

**Modulating Servo Motor:** Is an add-on valve component that permits HI/LO functionality to be controlled by the remote. Contrary to this feature is a Manual HI/LO Control Knob. The Modulating Servo Motor requires the Remote system to be present.

**Backup Battery Pack:** This component permits the IPI system to operate without the need for an external AC Adapter power source. The advantage to using the battery backup is that in the case of a power failure, the appliance is still

**NOTE:** In certain instances the IPI Main Module requires resetting. This can occur if the system is unable to ignite the pilot or the main burner in the allotted time period. The IPI is programmed to lockout all commands. To reset this lockout you must deplete the system of all electrical power. This means to remove the batteries from the Battery Pack, remove the batteries from the Remote Receiver (if applicable), and disconnect the AC Adapter from the system. Leave the power off for approximately 25 seconds to clear its lockout.

operable.

**Remote Receiver:** This component provides the capability of controlling the appliance with a wireless remote transmitter. There are two switches to note on the receiver module:

The first switch on the Remote Receiver module is a 3-position slide switch. This switch is used to either manually turn the main burner ON, activate the receiver to begin communication with the transmitter, or turn the main burner completely OFF. The position of the slide switch designates these functions respectively.

The second is the small round pushbutton [PRG] used for programming the receiver to respond to a designated remote. Therefore to program the system ensure that the transmitter is first turned OFF. Then, ensure that there is sufficient electrical power going to the Receiver module and a fresh set of batteries in the transmitter. Now switch the

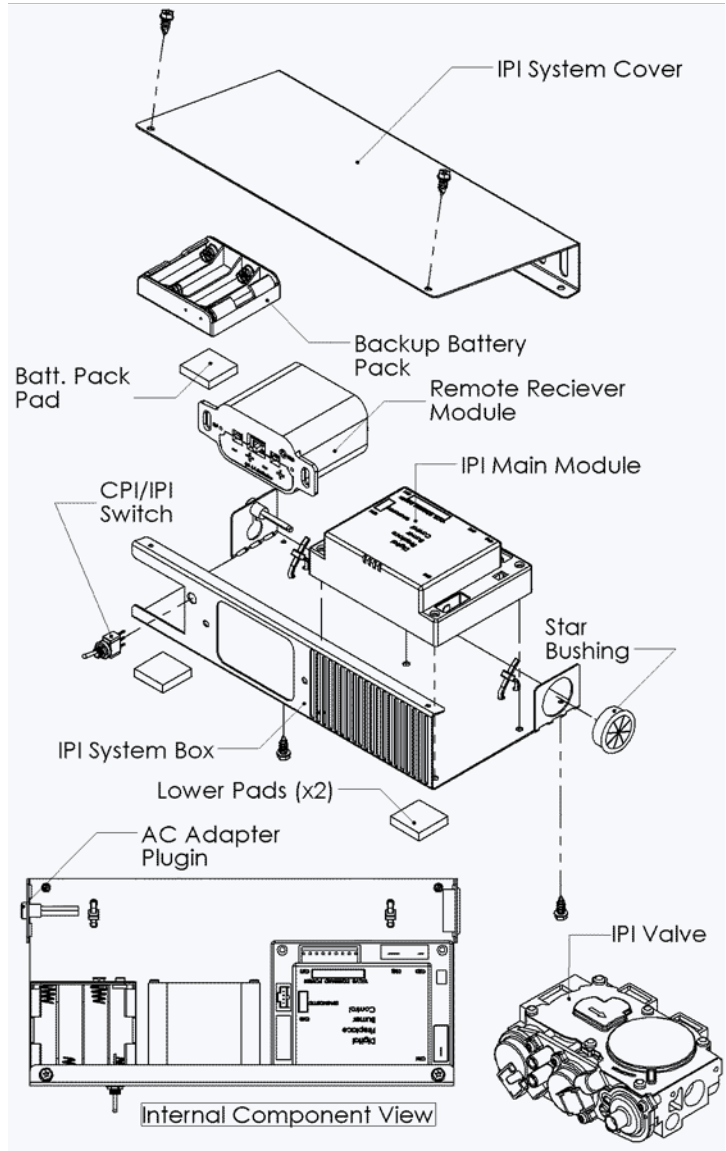

the slide switch to the middle [REMOTE] position and then push the small pushbutton to begin programming. Bring the transmitter close to the receiver and then press the power button [R] on the transmitter. An audible beep will sound to indicate the system is programmed and ready to be used.

**NOTE:** The Remote Receiver module can also be located outside of the appliance to a maximum of 6ft away installed in a certified deep wall switch electrical box (2-3/4" depth). For this configuration an extension wiring harness (P/N: 1001-P904SI) is required.

Electrical Supply in Series: The entire IPI system can be powered by a single power source (i.e. by the AC Adapter). This is advantageous if you do not want to supply extra batteries. To achieve this simply connect the AC Adapter into the Remote Control wiring harness instead of the main IPI harness. From the Remote wiring harness, use its male plug-in connector and connect it to the female plug-in in the main IPI harness. Now the circuit is complete. So the way it works is that electrical power is supplied to the Remote Receiver module and then proceeds to the Main IPI module. Furthermore, note that a Backup Battery Pack is not required in this configuration. Instead, batteries in the Remote Receiver act as the backup supply.

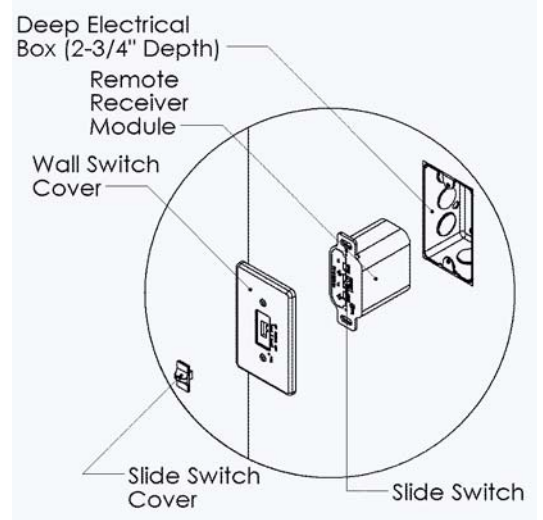

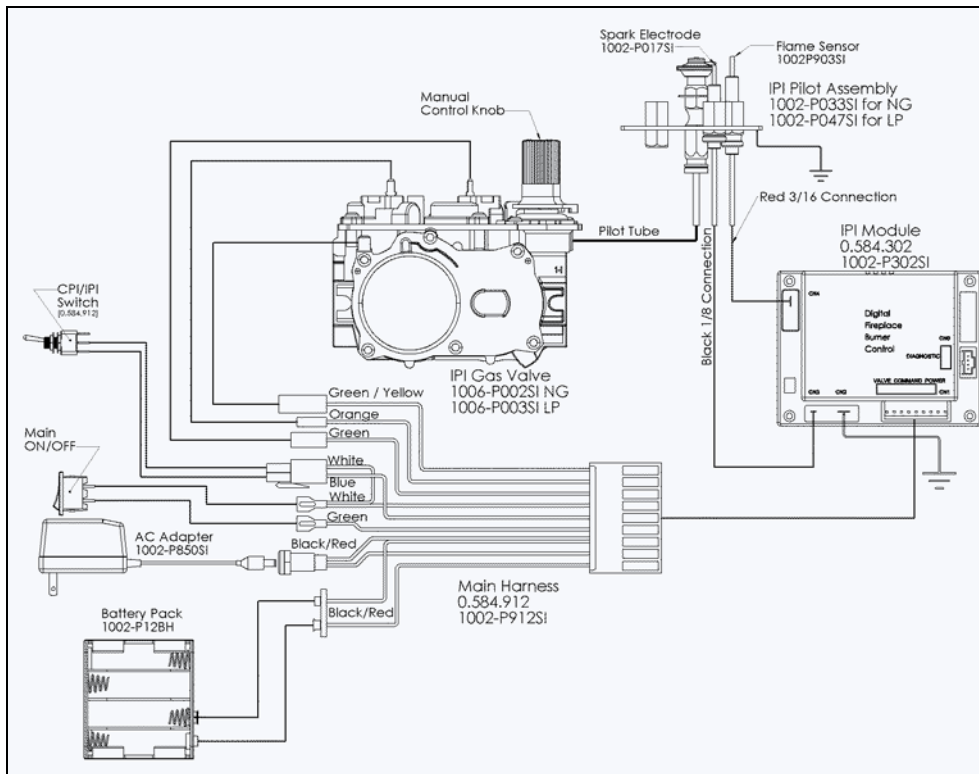

Configuration #1: Basic manual HI/LO and manual ON/OFF capabilities.

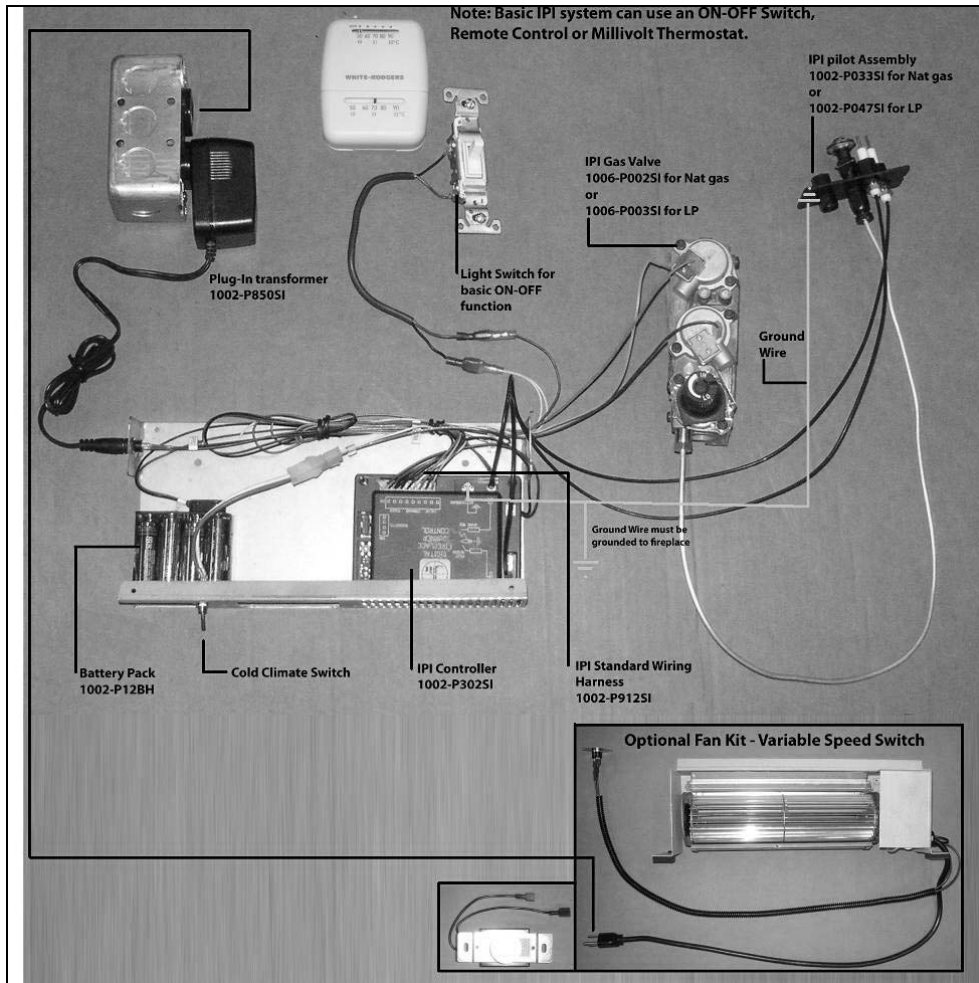



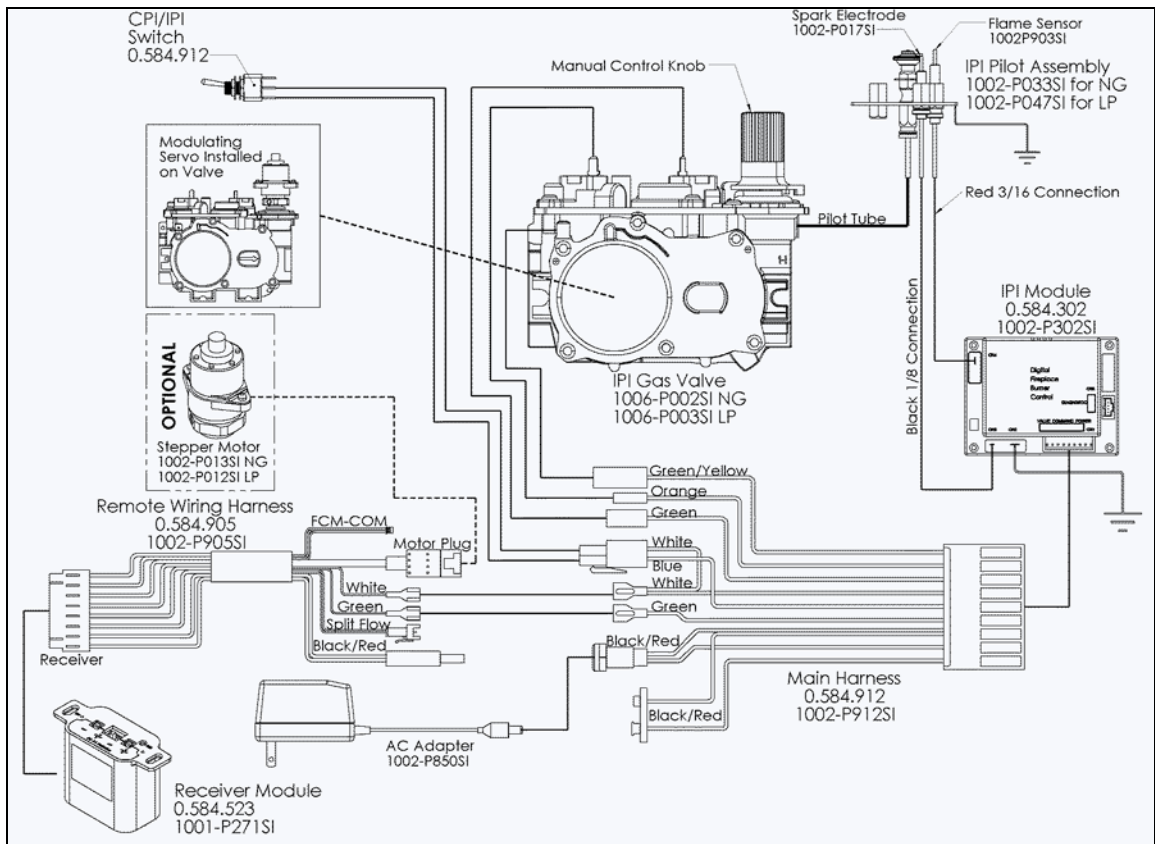

Configuration #2: Remote ON/OFF and manual HI/LO capabilities. OPTIONAL: For units with remote HI/LO capabilities, a modulating servo is required to be installed on the valve. The connectors to this servo must be connected to the Remote Harness as shown in the figure above.

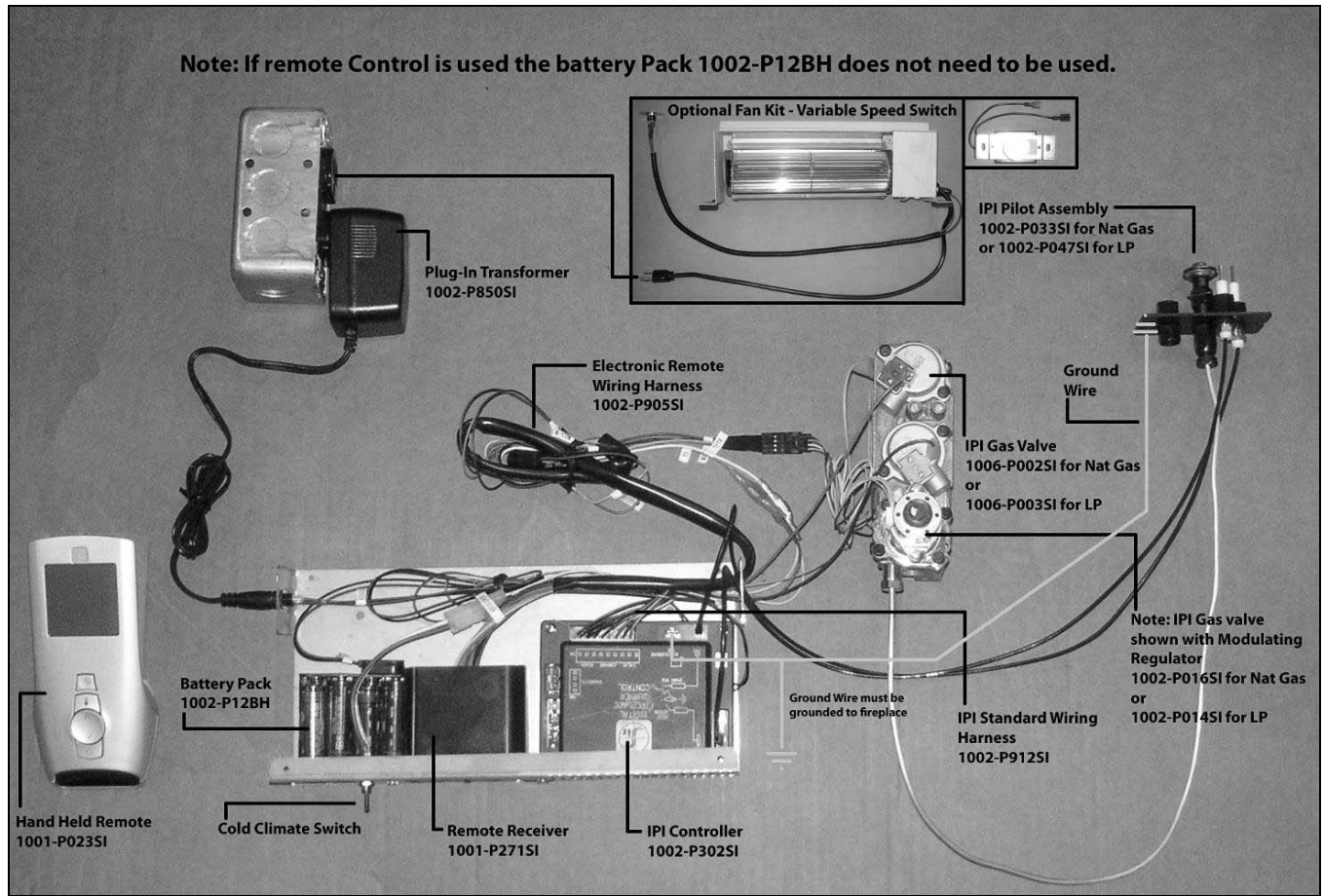

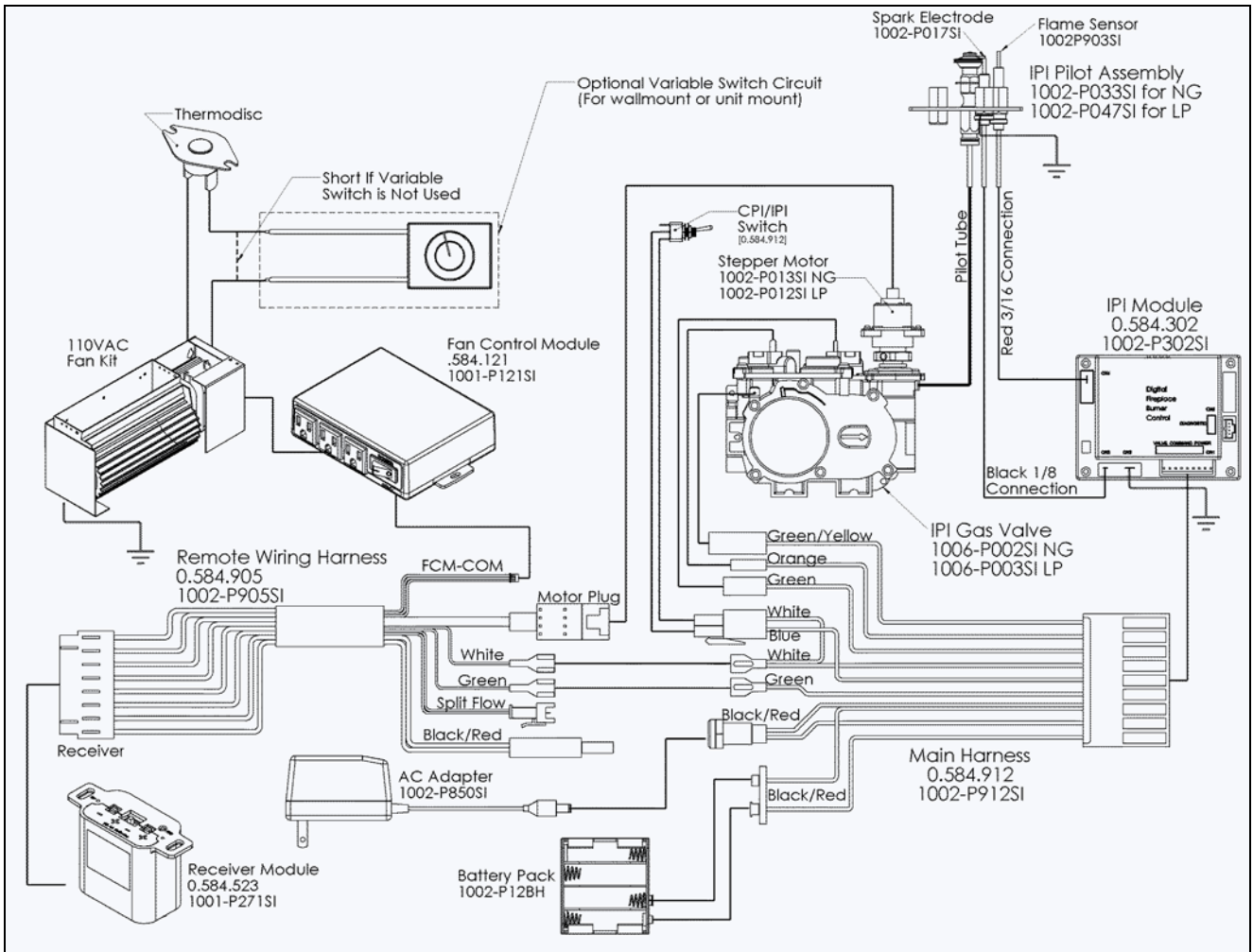

Configuration #3: Remote ON/OFF, variable HI/LO, and fan capabilities. Refer to the Fan Installation/Removal Guide section for fan installation.

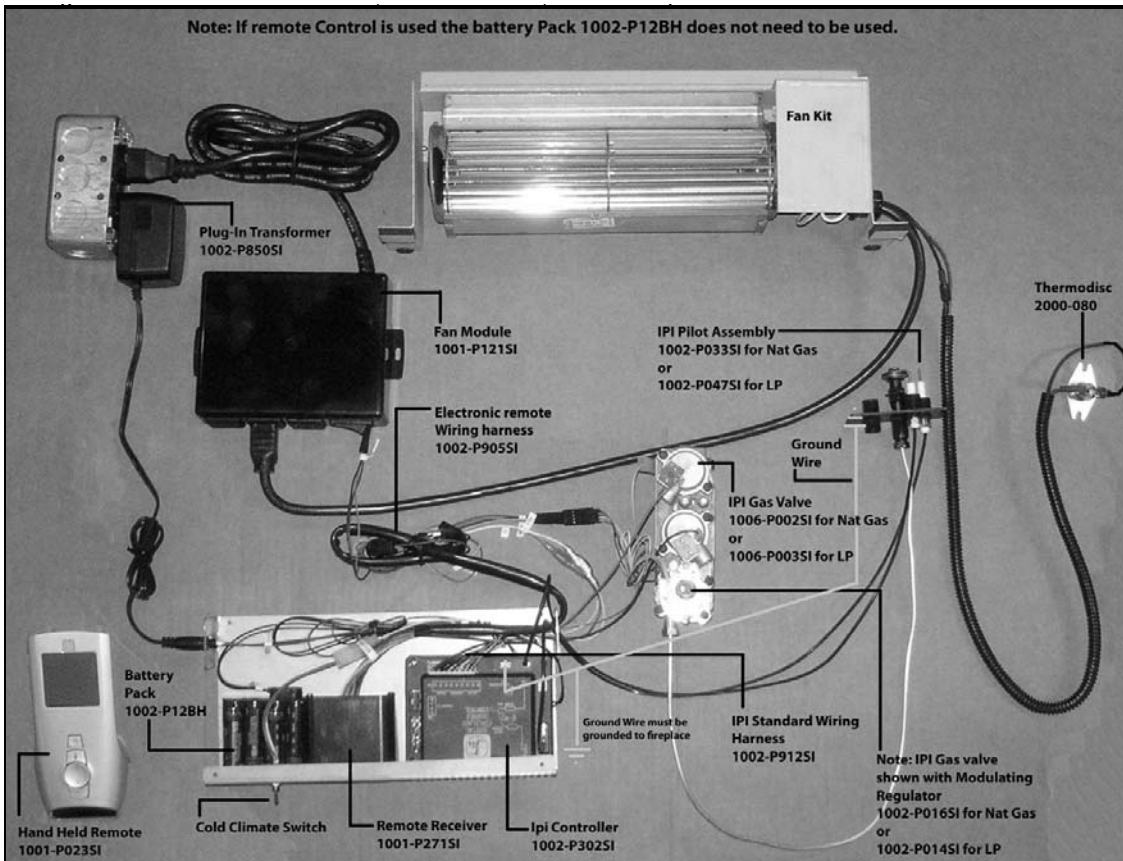

## IPI Lighting Instructions



### WARNING

1. If you do not follow these instructions exactly, a fire or explosion may result causing property damage, personal injury or loss of life.
2. Always light the pilot whether for the first time or if the gas supply has ran out with the glass door opened or removed.

### FOR YOUR SAFETY READ BEFORE LIGHTING



- A. This fireplace is equipped with an ignition device which automatically lights the pilot. Do not try to light by hand.
- B. Before operating smell all around the fireplace area for gas and next to the floor because some gas is heavier than air and will settle on the floor.
- C. Do not use this fireplace if any part has been under water. Immediately call a qualified service technician to inspect the fireplace and replace any part of the control system and any gas control which has been under water



### WHAT TO DO IF YOU SMELL GAS

- |  |  |
|--|--|
| <ol style="list-style-type: none"><li>1. Turn off all gas to the fireplace.</li><li>2. Open windows.</li><li>3. Do not try to light any appliance.</li><li>4. Do not touch any electric switch; do not use any phone in your building.</li></ol> | <ol style="list-style-type: none"><li>5. Immediately call your gas supplier from a neighbor's phone. Follow the gas supplier's instructions.</li><li>6. If you cannot reach your gas supplier, call the fire department.</li></ol> |
|--|--|

### LIGHTING INSTRUCTIONS

1. STOP! Read the above safety information on this label.
2. Remove batteries from Receiver and/or Battery Backup Pack.
3. Turn off all electric power to the fireplace.
4. This fireplace is equipped with an ignition device which automatically lights the pilot. Do not try to light the pilot by hand.
5. Open the glass door.
6. Turn manual shutoff valve clockwise  to OFF position (located behind the access panel).
7. Wait five [5] minutes to clear out any gas. If you smell gas including near the floor, STOP! Follow "B" in the above safety information on this label. If you don't smell gas go to the next step.
8. Turn manual shutoff valve counter-clockwise  to ON position.
9. Close the glass door.
10. Turn on all electric power to the fireplace, and re-install batteries into the Transmitter/Receiver and/or Battery Backup Pack.
11. Turn ON the switch that operates the Main Burner. If using a Remote Control refer to Remote Control Operation Manual for activation.

### TO TURN OFF GAS

1. Turn OFF all electric power to the fireplace if service is to be performed, including removing batteries from the Remote Transmitter/Receiver and/or Battery Backup Pack.
2. Access door inside the firebox must be removed to access the manual shutoff valve.
3. If alternate shut-off valve was installed it can be shutoff instead of going through the fireplace to access the fireplace shut off valve.

## Trouble Shooting The Gas Control System



**WARNING:** BEFORE DOING ANY GAS CONTROL SERVICE WORK, REMOVE THE GLASS FRONT.

**NOTE:** Before troubleshooting the gas control system, be sure external gas shut off is in the “On” position.

Problem	Possible Causes	Corrective Action
Spark igniter will not light.	Defective or misaligned electrode at pilot.	Check for spark at electrode and pilot: if no spark and electrode wire is properly connected, replace igniter.
	Defective igniter (push-button)	Using a match, light pilot. If pilot lights, turn off pilot and push the red button again. If pilot will not light - check gap at electrode and pilot should be 1/8" to 1/4" to have a strong spark.
Pilot will not stay lit after carefully following lighting instructions.	Defective thermocouple (flame switch where applicable)	Check pilot flame. Must impinge on generator and thermocouple. Clean and/or adjust pilot for maximum flame impingement on generator and thermocouple. Replace thermocouple if pilot will not hold. (Hand tight 1/8 turn on replacement)
	Defective valve magnet.	Replace valve, if pilot won't hold after the thermocouple is replaced.
Pilot burning, no gas to burner, Valve knob “ON”, Wall Switch “ON”	Wall switch or wires defective.	Check wall switch and wires for proper connections. Jumper wire across terminals at wall switch. If burner comes on, replace defective wall switch. If okay, jumper wires, across wall switch wires at valve. If burner comes on, wires are faulty or connections are bad.
	Generator may not be generating sufficient voltage.	Check generator with millivolt meter. Take reading at generator terminals of gas valve. Should read 325 millivolts minimum while holding valve knob depressed in pilot position and wall switch “off” Replace faulty generator if reading is below specified minimum.
	Plugged burner orifice.	Check burner orifice for stoppage and remove.
	Defective automatic valve operator.	Remove wall switch wires from gas valve. Install jumper wires from top bottom terminals of gas valve. Turn valve on “ON”. If main burner does not light, replace valve.
Frequent Pilot outage problem.	Pilot flame may be too low or blowing (high) causing the pilot safety to drop out.	Clean and/or adjust pilot flame for maximum flame impingement on generator and thermocouple.
Flame lifts off burner and goes out in less than 30 seconds	Inner 4" liner has come off flue or termination, flame is starving	Attach 4" liner to flue or termination using screws, silicone and clamps as stated in manual for oxygen
Flame lifts off burner on one side while the rest of the flame remains lit.	Improper installation of firebrick. Firebrick is likely leaning.	Be sure to position firebrick against firebox walls and be sure to use brick clips attached to the inner side of firebox.

## Field Conversion for ZDV6000 - VFI25 - VFI30



**WARNING:** Failure to position the parts in accordance with these diagrams or failure to use only parts specifically approved with this appliance may result in property damage or personal injury.

C6GEK: ZDV6000 Conversion  
 2 - Ember Plates  
 1 - Ember Plate Bridge  
 1 - Grate Assembly with 5/8" Bars  
 4 - 1/2" x 8-18 DT Screws

C30GEK: VFI25 & VFI30 Conversion  
 2 - Ember Plates  
 1 - Ember Plate Bridge  
 1 - Grate Assembly with 1/2" Bars  
 2 - 1/2" x 8-18 DT Screws

Tools Required: Drill, 1/8" Drill Bit, 1/4" Nut Driver Bit

Step 1: Remove existing grate bar by bending bar slightly forward and drill out rivets.

Step 2: Seal rivet holes with two supplied screws. (ZDV6000 ONLY)

Step 3: Center legs of Grate Bar on either side of burner support and fasten with supplied self drilling Screws. (Ref: 1)

Step 4: Place Ember Plates between burner tubes right and left of Burner.

**NOTE:** Raised flange of Ember Plates must be to back of Burner.

Step 5: Slide Ember Plate Bridge between Ember Plates. (Ref: 2)

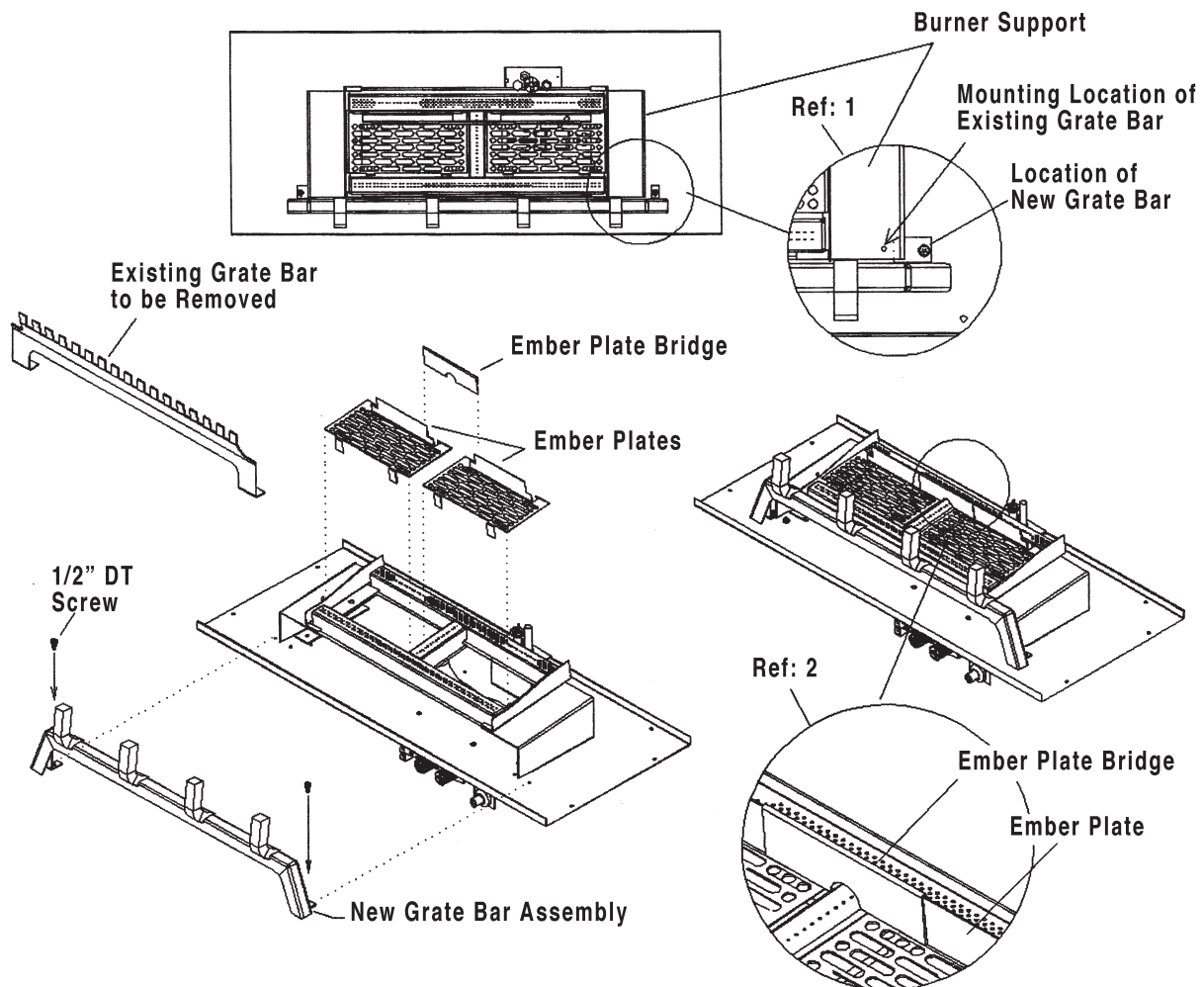

## LOGC5 or LOGF5 Setup for Model ZDV6000



C5 or F5 Parts

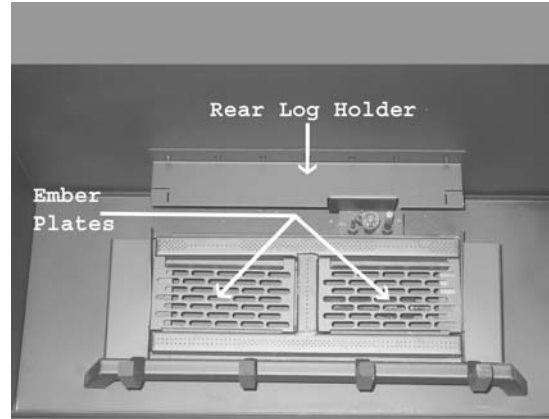

Burner

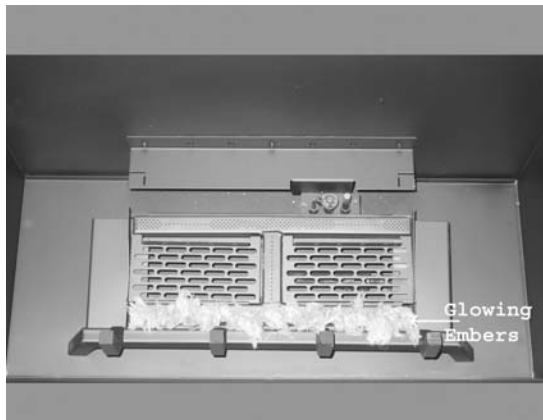

**Step 1:** Break ember wool into thumbnail size pieces. Place glowing embers evenly on to the front burner tube as shown.

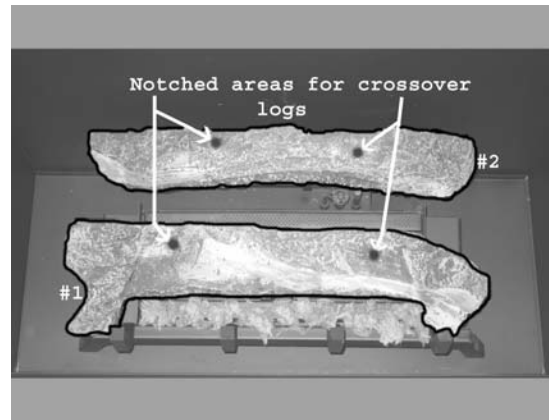

**Step 2:** Place Log #1 on burner as shown and pull forward to the grate bars. Place log #2 on rear log holder and center it.

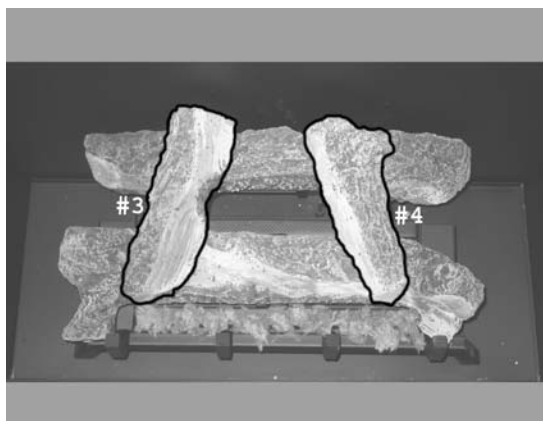

**Step 3:** Place Log #3 onto the notched areas as shown. Place Log #4 onto the notched areas as shown. (Refer to step 2 for notched area locations).



**Step 4:** Place lava rock around the sides and the front of the burner as shown. Sprinkle vermiculite over top of the lava rock as shown. (Do not place lava rock or vermiculite on the burner tube areas).

# LOGC6 Setup for Model ZDV6000

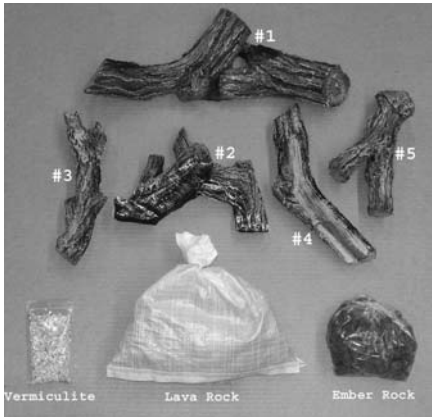

Log C6 Parts List

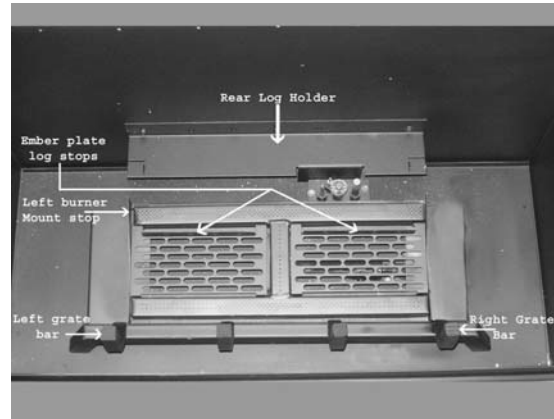

Burner

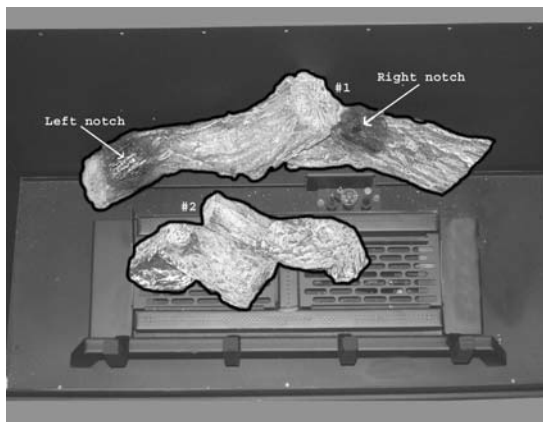

**Step 1:** Place Log #1 on rear log holder, center it, and push back. Place Log #2 against the left burner mount and back against the ember plate log stop as shown. (Log must not impinge on main flame pattern).

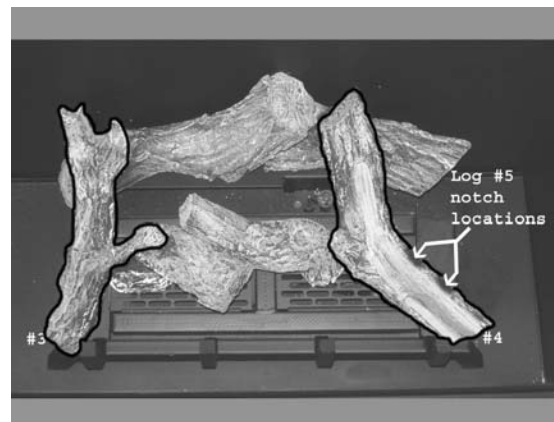

**Step 2:** Place Log #3 onto the left notch of Log #1 and against the left grate bar as shown. Place Log #4 onto the right notch of Log #1 and against the right grate bar as shown.

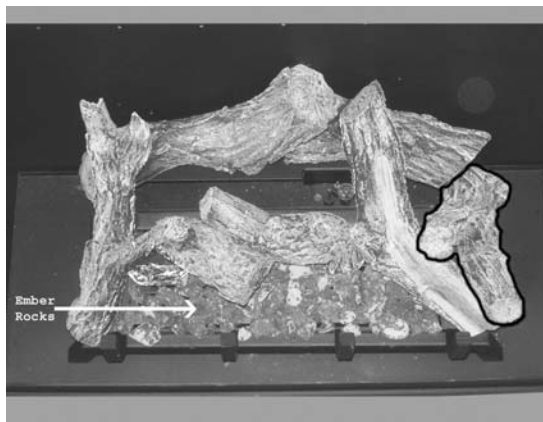

**Step 3:** Place Log #5 on the notched locations of Log #4. (Refer to step 2 for Log #5 notch locations). Fill the exposed areas of the ember plates and front burner tube with ember rocks. (Do not place ember rocks on rear burner tube).

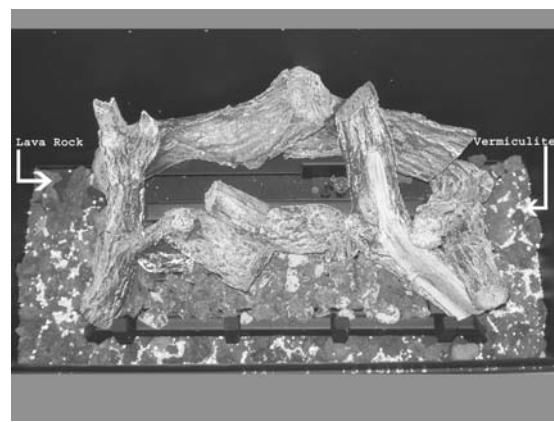

**Step 4:** Place lava rock around the sides and front of the burner. Sprinkle the vermiculite over top of the lava rock. (Do not place lava rock and vermiculite on burner or ember plates).

# MOROCK1/MORSP6 Setup for Model ZDV6000



## Parts List



**Step 1:** Remove the 2 grate bar screws and remove the grate bar.

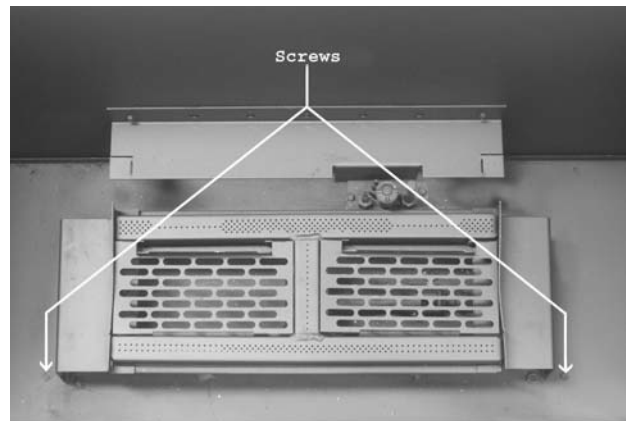

**Step 2:** Replace/reinstall the 2 screws from the grate bar.

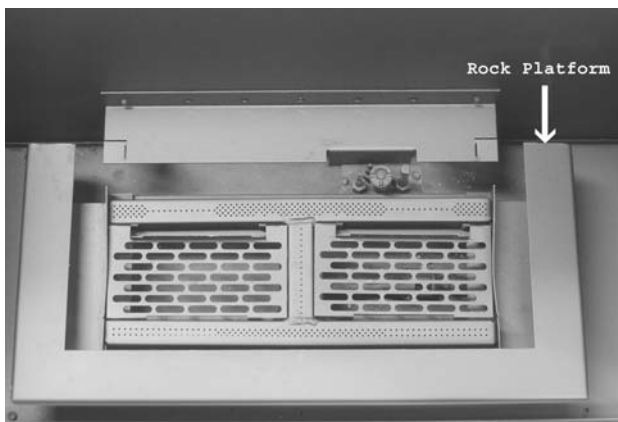

**Step 3:** Slide the rock platform around the burner and push it towards the back of the fire box.

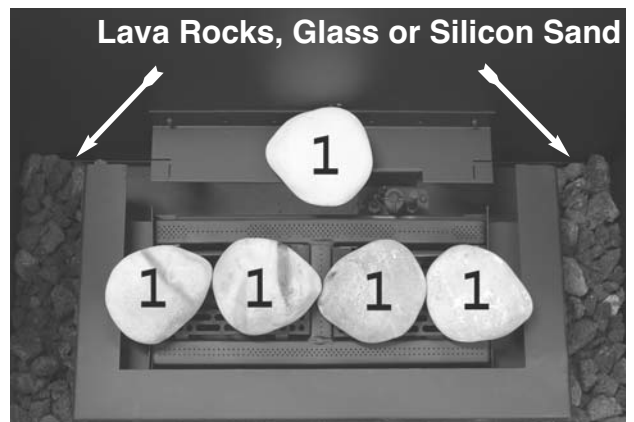

**Step 4:** Place rocks #1 on to the burner as shown.



## MOROCK1/MQRSP6 Setup for Model ZDV6000 (Cont.)

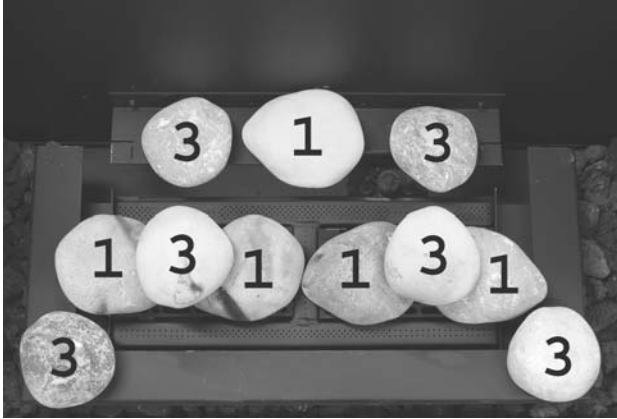

**STEP 5:** Place rocks #3 into position as shown.



**STEP 6:** Place rocks #6 into position as shown.

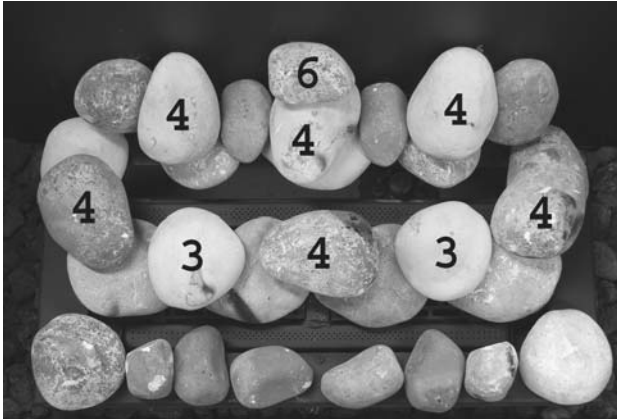

**STEP 7:** Place remaining rocks number 4 and 6 into position as shown.

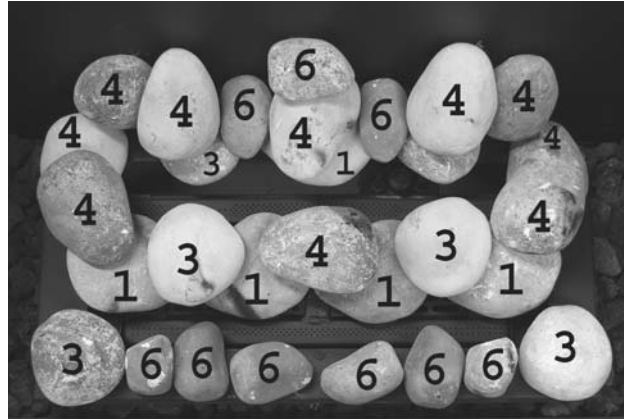

**Finished Rock Setup**

**\*\* Do not place any of the rocks directly over the burner tubes.**

## LOGC42/LOGC43 Placement Guidelines for Model ZDV3320



**FIGURE A** - Log set Ember kit and crushed rock.



**FIGURE B** - Rear log holder

**STEP 1:** Units are equipped with screws or latches. To remove glass door, either remove screws or unfasten latches and lift door off bottom door retainer.

**STEP 2:** Remove logs from carton and inspect each log.

**STEP 3:** Verify to see that the ember plates (2 pcs) are between front and back burner.



**STEP 4:** Break glowing embers into thumbnail size. Place glowing embers on to the surface of the front burner, to the surface of the ember plates and over crossover to the same height as ember plates. Height on front burner 1/2" to 3/4". Height on ember plates 3/4" to 1". Do not cover back air openings on ember plates.



**STEP 5:** Place front log over front burner, against decorative grate. Be sure that front log is tight up against the decorative grate.

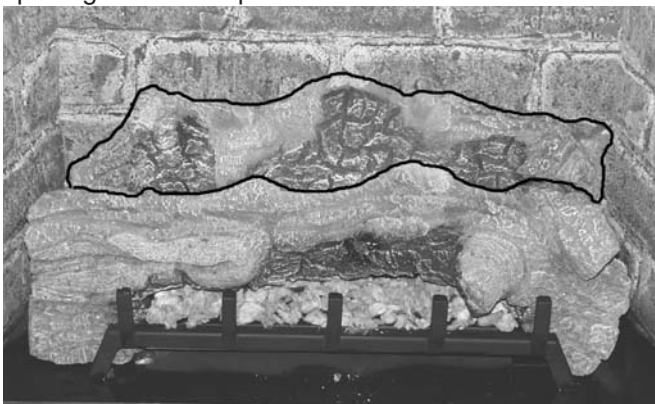

**STEP 6:** Place rear log on to the log retainer 1/2" away from back of fireplace. (If refractory liner is used, make sure refractory liner is installed first then back log is to be pushed up against it as tight as possible.)



**STEP 7:** Place right crossover log across front and back logs using the log placement pin as a guide.

## LOGC42/LOGC43 Placement Guidelines for Model ZDV3320 (continued)

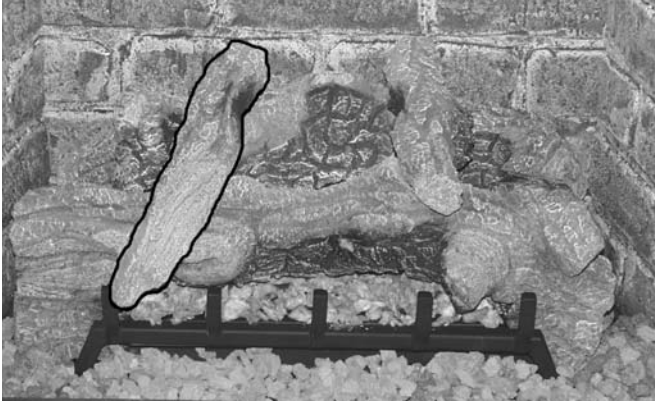

**STEP 8:** Place left crossover log across front and back logs using the log placement pin as a guide.

**STEP 9** Place decorative moon rock on bottom of fireplace to simulate ash.

**DO NOT PUT ANY ROCK ON BURNERS!**



**Step 10:** Purge lines and test pilot operation.

**Step 11:** Replace glass door.

## LOGC44 Placement Guidelines for Model ZDV3320

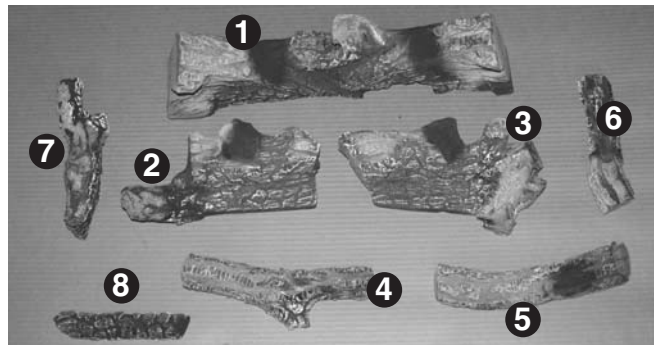

**FIGURE A -** Log set Ember kit and Crushed rock.

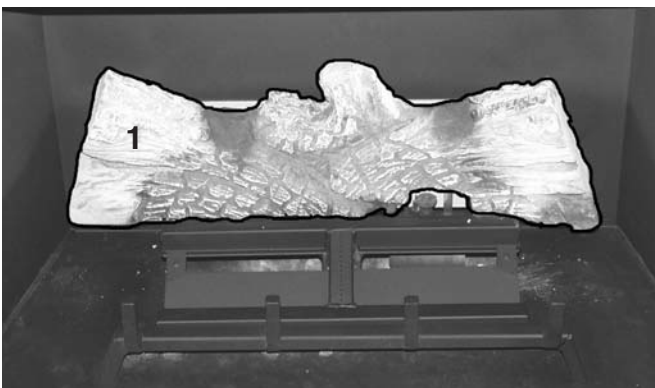

**STEP 1:** Position rear log over rear log holder and lower into position. Be sure the log does not sit on rear burner, but behind and lower than burner.

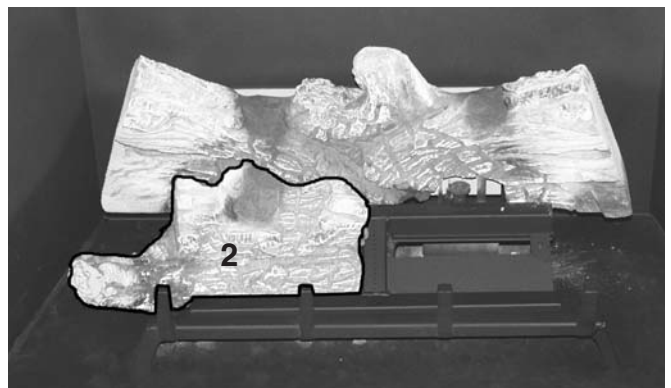

**STEP 2:** Locate flat surface on Log(2) and place directly onto left ember plate, push log fully to the right until it touches the crossing tube.

## LOGC44 Placement Guidelines for Model ZDV3320 (continued)

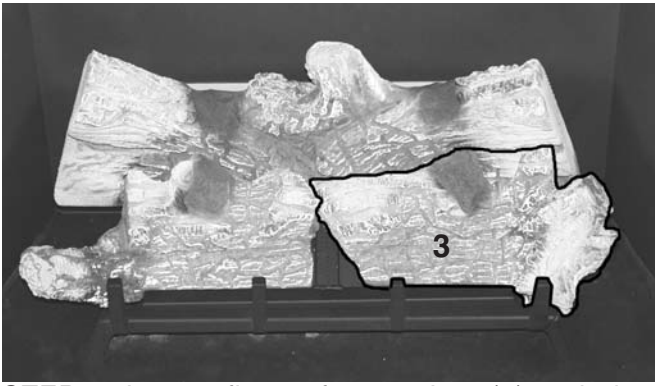

**STEP 3:** Locate flat surface on Log (3) and place directly onto right Ember plate, push log fully to the left until it touches Log (2).

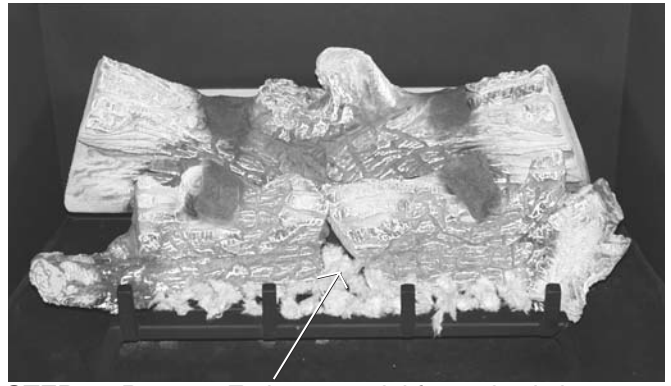

**STEP 4:** Remove Ember material from plastic bag, tear off dime and nickel sized pieces and place directly onto front burner tube and crossover tube. (NOTE: Do not place embers onto rear burner tube.)

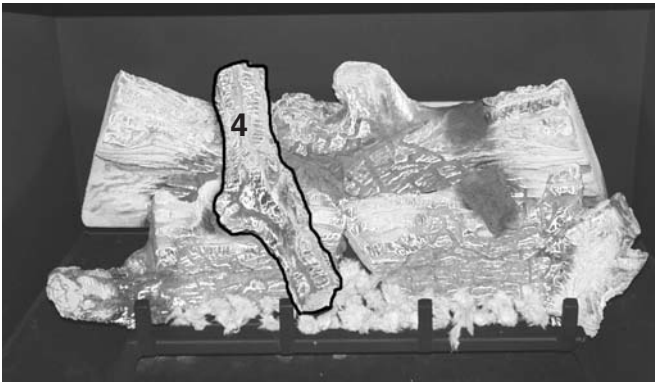

**STEP 5:** Position Log (4) into grooved areas of Logs (1) and (2)

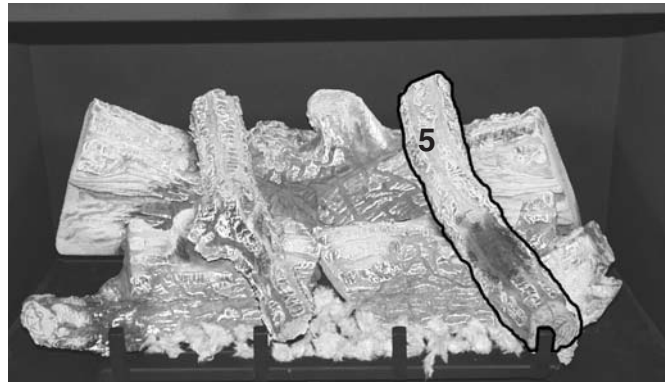

**STEP 6:** Position Log (5) into grooved areas of Logs (1) and (3)

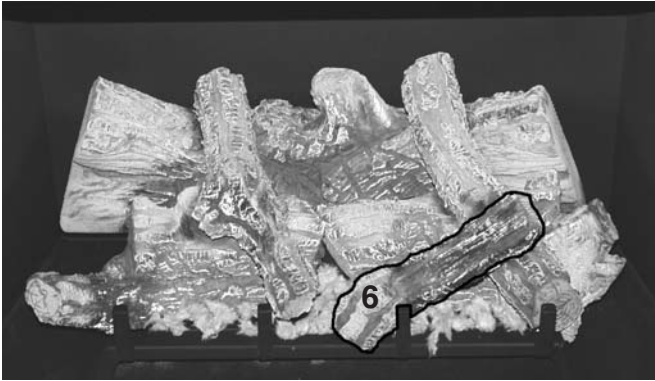

**STEP 7:** Position Log (6) up against the 2nd grate post from the right, and position upper section of Log (6) into grooved area of Log (5).



**STEP 8:** Slide Log (7) between Log (1) and Log (2).



**STEP 9:** Position Log (8) up against the 3rd grate post from the right, and position upper section of Log (8) against Logs (2) and (7).

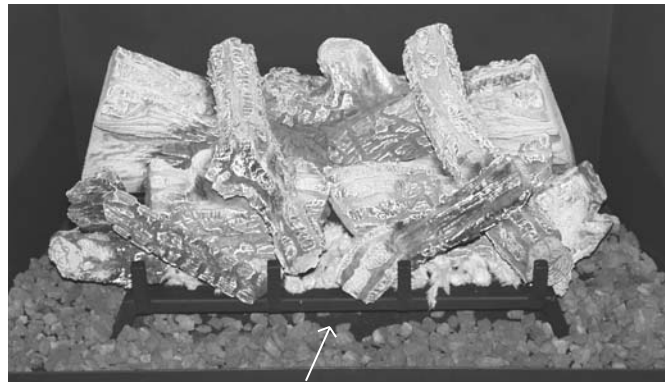

**STEP 10:** Place crushed rocks onto fire box bottom. (NOTE: Do not place crushed rock onto burner tubes)

## MOROCK1/MORSP3 Setup for ZDV3320



Parts List



**Step 1:** Remove the 2 grate bar screws and remove the grate bar.



**Step 2:** Replace/reinstall the 2 screws from the grate bar.

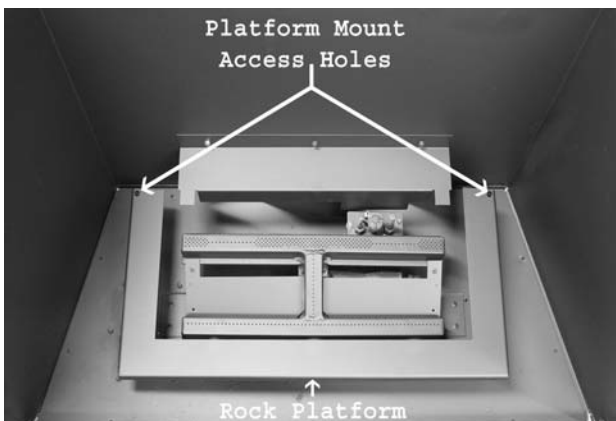

**Step 3:** Using the rock platform mount holes, attach the rock platform to the burner pan as shown.



**Step 4:** Fill around the rock platform with lava rock. Sprinkle vermiculite over the top of the lava rock. **Do not place lava rock or vermiculite on the burner tube.**

## MOROCK1/MQRSP3 Setup for ZDV3320 (Cont.)

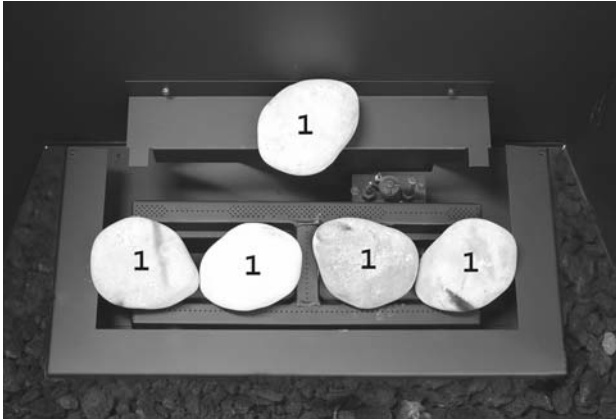

**Step 5:** Place rocks #1 onto the burner as shown. Do not place rocks directly onto the burner tubes.

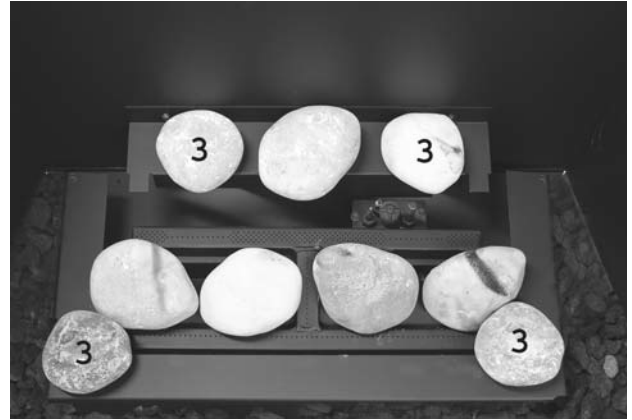

**Step 6:** Place rocks #3 into position as shown. Do not place rocks directly onto the burner tubes.



**Step 7:** Place rocks #4 into position as shown.

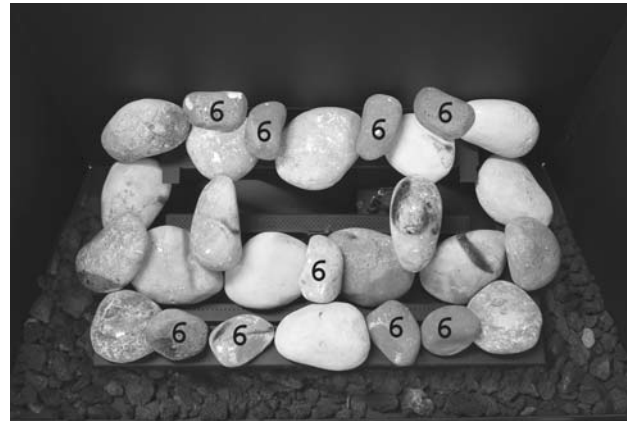

**Step 8:** Place rocks #6 into place as shown.

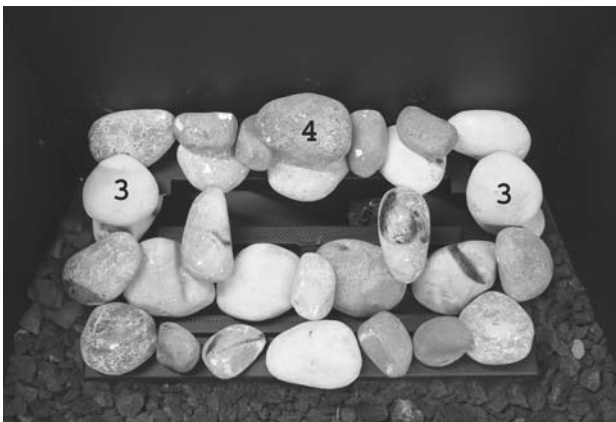

**Step 9:** Place remaining rocks #3 and #4 into position as shown or at random.

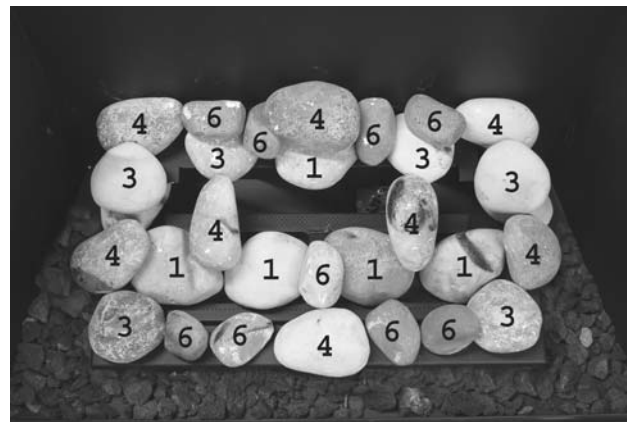

**Finished Rock Setup**

• **Never place any of the rocks directly onto the burner tubes.**

## Accessories for MQRB3328, MQRB3632, MQRB4236

The following options are available for the MQRB Series. Each option may be used independently or in combination with any other.

- #1: Bag of Silica Sand - Supplied with unit
- #2 MQRBD1 Rock and Log Kit - 4 Rocks and 4 Drift Wood Logs
- #3 MQ Ember Kit - 2 Bags of Glowing Embers



- #4: MQ Rock 1 - Box of 30 Rocks (Shown in option 4 below)
- #5 MQG10W or MQG10B - Decorative Glass White or Black

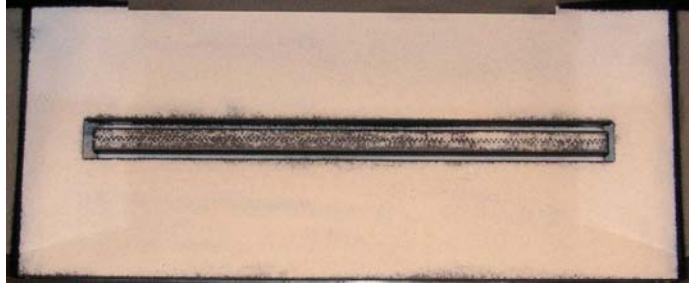

**Option #1** -Sand-The MQRB Ribbon Burners are supplied with 1 bag of sand which may be spread across the False Bottom if desired.

**Note:** -Silica Sand may be used with or without Options #2, #3, and #4.

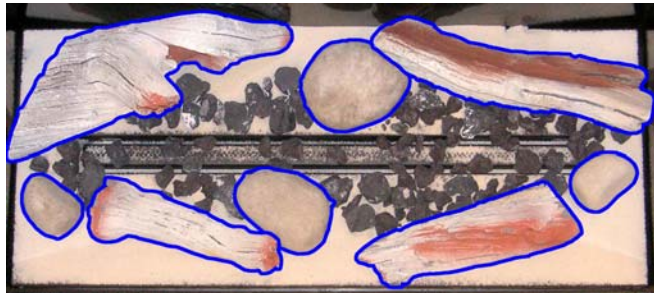

**Option #2-MQRBD1 Rock and Log Kit-** Place rocks and logs onto False Bottom randomly as shown. Be careful not to cover any part of the Burner Tube as sooting may occur.



**Option #3 -MQ Ember Kit-** Place these glowing ember chunks randomly as shown. No more than 20% of the burner tube should be covered (approx. 12-14 ember chunks).



**Option #4 -MQ Rock 1 MCQ Rock Kit-** Place rocks randomly onto False Bottom as shown. Be careful not to cover any part of the Burner Tube as sooting may occur.



**OPTION #5 - MQG10W OR MQG10B -** Spread Decorative Glass onto false bottom as desired making sure no Glass is placed onto the burner tube. See Photo.

# Vent Termination

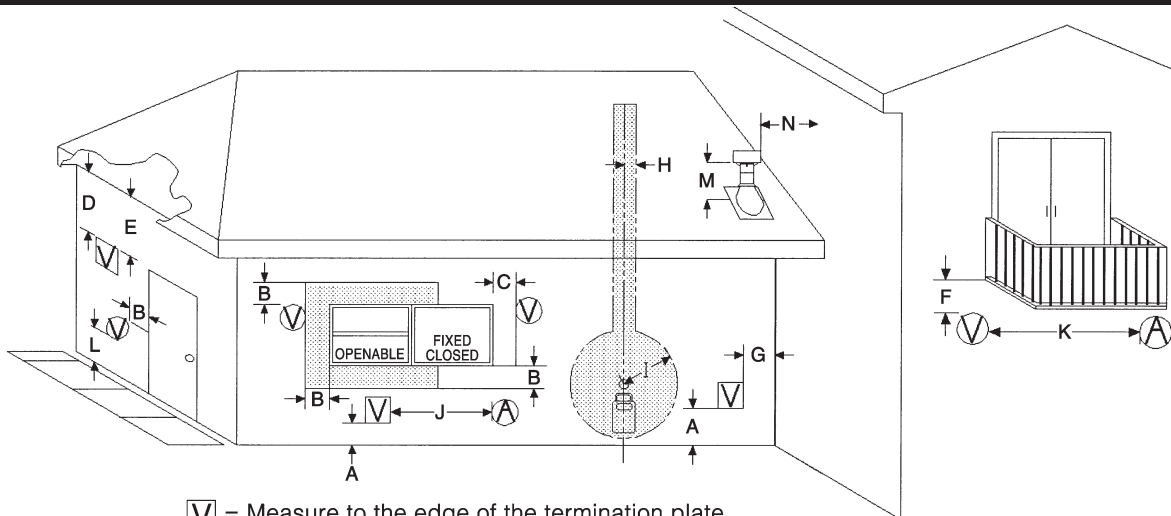

∇ = Measure to the edge of the termination plate.

⊙ = Measure to the edge of the round termination.

∇ Vent Terminal

⊙ Air Supply

■ Area Where Terminal Not Permitted.

- A - Clearance above grade, veranda, porch, deck, or balcony 12 inches (30cm) minimum.<sup>1,2</sup>
- B - Clearance to window or door that may be opened. 12 inches (30cm) minimum for appliances 100 000 Btuh (30 kW) and lower, in Canada. 9 inches<sub>2</sub> (23cm) for appliances 50 000 Btuh and lower, in USA.
- C - Clearance to permanently closed window minimum 12 inches (30cm) recommended to prevent condensation on window, in Canada. 9 inches<sub>2</sub> (23cm) for appliances 50 000 Btuh and lower, in USA.
- D - Vertical clearance to ventilated soffit located above the termination within a horizontal distance of 2 feet (60cm) from the center line of the termination. 18 inches (46cm) minimum.<sup>5</sup>
- E - Clearance to unventilated soffit 12 inches (30cm) minimum.
- F - Clearance under veranda, porch, deck or balcony 12 inches, (30cm) minimum.<sup>4</sup> US<sub>5</sub>
- G - Clearance from a perpendicular inside wall or outer corner to the edge of the vent terminal plate is 3" (minimum).
- H - Clearance to each side of center line extended above meter/regulator assembly 3 feet (91cm) within a height 15 feet (4.5m) above the meter/regulator assembly.
- I - Clearance to service regulator vent outlet 3 feet (91cm) minimum.<sup>1</sup> US<sub>5</sub>
- J - Clearance to non-mechanical air supply inlet to building or the combustion air inlet to any other appliance: In Canada, 6 inches (15cm) for appliances ≤10,000 Btuh (3kW), 12 inches<sub>1</sub> (30cm) minimum for appliances >10,000 Btuh (3kW) and ≤100,000 Btuh (30kW), 36 inches (91cm) for appliances >100,000 Btuh (30kW). In the USA, 6 inches<sub>2</sub> (15cm) for appliances ≤10,000 Btuh (3kW), 9 inches (23cm) for appliances >10,000 Btuh (3kW) and ≤50,000 Btuh (15kW), 12 inches (30cm) for appliances >50,000 Btuh (15kW).
- K - Clearance to a mechanical air supply inlet 6 feet (1.8m) minimum, in Canada. In USA, 3 feet (91cm) above if within 10 feet<sub>2</sub> (3m) horizontally.
- L - Clearance above paved sidewalk or a paved driveway located on public property 7 feet (2.1m) minimum.<sup>3</sup>
- M - Clearance above highest point of exit on roof 18 inches (45cm).
- N - Clearance to perpendicular wall 24 inches (60 cm). (Recommended to prevent re-circulation of exhaust products. For additional requirements check local codes.)

**NOTE: Clearances are to the edge of terminal plate, add 6-3/4" to clearances to arrive at center line.**

**NOTE: Local Codes or Regulations may require different clearances.**

## Termination

It is imperative that the vent termination be located observing the minimum clearances as shown. There must not be any obstruction such as bushes, garden sheds, fences, decks or utility buildings within 24" from the front of the termination plate.

Do not locate termination where excessive snow or ice build-up may occur. Be sure to check vent termination area after snow falls and clear to prevent accidental blockage of venting system. When using snow blowers, make sure snow is not directed towards vent termination area.

## General Venting Information

The gas fireplace is approved to be vented either through the side wall or vertically through the roof.

This appliance is approved with Kingsman Flex(Z-Flex) vent system and also approved for use with Simpson Duravent Direct Vent System (model DV-GS series), AmeriVent Direct Vent Pipe System, ICC Excel Direct, Metal Fab Sure-Seal DV and Selkirk Direct Temp.

Kingsman Flex(Z-Flex)Venting Kits can be used with Simpson Duravent Direct Vent termination's (model DV-GS series). When using Simpson Duravent, AmeriVent Direct Vent pipe, ICC Excel Direct, Metal Fab Sure-Seal DV or Selkirk Direct Temp a Kingsman/Duravent adapter must be used.

**ONLY VENTING COMPONENTS SPECIFICALLY APPROVED AND LABELED FOR THIS FIREPLACE MAY BE USED.**

Venting terminal shall not be recessed into a wall or siding. If finishing the outside wall with vinyl or wood siding it is recommended that a Siding Shield be installed, Part Number ZDVSSLR.

- 1 - In accordance with the current *CSA B149.1, Natural Gas and Propane Code*.
- 2 - In accordance with the current *ANSI Z223.1/NFPA 54, National Fuel Gas Code*.
- 3 - A vent shall not terminate directly above a sidewalk or paved driveway that is located between two single family dwellings and serves both dwellings.
- 4 - Permitted only if veranda, porch, deck, or balcony is fully open on a minimum of two sides beneath the floor.
- 5 - Clearance in accordance with local installation codes and the requirements of the gas supplier.



## General Vent Installation Information

This gas appliance is approved to be vented either through the side wall or vertically through the roof. **Only Kingsman Flex(Z-Flex)Venting Kits and components specifically approved and LABELED for this stove may be used.** This appliance is also approved for use with Simpson-Duravent Direct Vent system (Model DV-GS Series), Ameri-Vent Direct Vent Pipe System, ICC Excel Direct, Metal Fab Sure-Seal DV and Selkirk Direct Temp.

**Simpson Dura-Vent for Masonry Chimney Conversion Kits** may be used with this appliance Use your existing masonry chimney and route the exhaust gases intake air through the side of the masonry chimney. Use Simpson Dura-Vent kit numbers 46DVA-KMC or 46DVA-KCT. Termination Cap, Kingsman/Dura-Vent adapter, and 4" flex are sold separately.

**Simpson Dura-Vent for Factory built metal Chimney Conversion Kits** may be used with this appliance. Use your existing through the ceiling, wood stove chimney and route the exhaust gases and intake air through the existing wood burning metal chimney. Use Simpson Dura-Vent Kit numbers 46DVA-KCA for 6 5/8" to 8 5/8" OD sized chimney, 46DV-KCB for 8 3/4" to 10 1/2" OD sized chimneys and 46DVA-KCC for 10 5/8" to 13" OD sized chimneys. Kits 931, 932, and 933 include a cap adapter and Retro Connector. Termination Cap, Kingsman/Dura-Vent adapter, and 4" flex are sold separately.

### RIGID OR HARD PIPE

When using Simpson Duravent, AmeriVent pipe, ICC Excel Direct, Metal Fab Sure-Seal DV and or Selkirk Direct Temp a Duravent hardpipe adapter must be used (**part # ZDV DFA for fireplaces and part # ZDV DKA for Stoves, Serenity and ZDV3624B**). Follow installation instructions provided by Simpson Duravent/AmeriVent/Selkirk Direct Temp, ICC Excel Direct, Metal Fab Sure-Seal DV for installation of pipe and adhere to the clearance to combustibles provided in this manual. Apply a bead of Mill Pac high temp sealant to all joints of pipes, adapters and termination, when using Kingsman Flex(Z-Flex)Venting venting and Simpson Duravent venting.

**NOTE:** Increase framing depth by one inch when using hardpipe.



**WARNING:DO NOT** mix parts from different systems unless stated in the manual.

### Flex Pipe Venting

Kingsman Flex pipe is shipped in unexpanded length. When installing pipe expand the lengths. Pipe can be expanded to twice their lengths e.g. 4ft. to 8ft. Fully expand pipe and cut off excess.

Do not use more than 2 couplers to extend short pipes. Single sections are preferred in an installation attaching at the fireplace and termination.

Place the spring spaces provided approximately every two feet to stabilize 4" flex in the center of 7" flex. When forming bends place spring in bend or before and after. (See Fig. 1).

Horizontal runs require support metal straps every 2 feet. In off set installation support straps should be used to stabilize pipe.

Expand 4" and 7" flex pipe to the point that the 7" protrudes approximately 2 to 3 inches past outer wall and the 4" flex protrudes approximately 2 to 3 inches past the 7" flex. See Fig. 1.

Attach the 4" pipe to the termination first and secure with sealant and 4 (four) screws then attach the 7" flex to the termination with caulking and screws. Termination may then be moved back to the outer wall and attached to home screwing into the framing. Silicone around termination to waterproof. If siding shield is going to be used attach this using same attaching hole as the top of termination after termination has been caulked for water proofing.

### Use Hi Temp Sealant

Apply a bead of mill pac high temp sealant to all joints and use four screws to secure each pipe at fireplace, termination and any joint if joining any sections of pipe.

### FRAMING DIMENSION

#### Combustible Wall

Cut a 11" hole through exterior wall and frame as shown below.

#### Non combustible Wall

Cut or drill 8" or 204mm diameter hole.

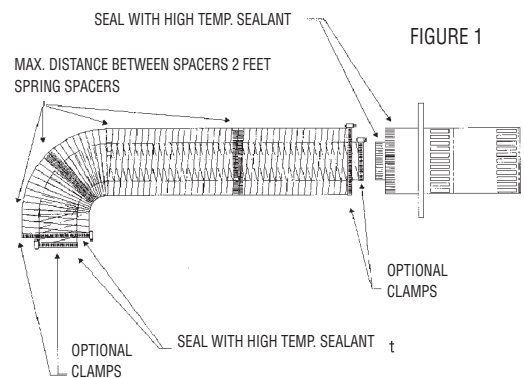

**NOTE:** It is critical to the proper and safe operation of this fireplace that on all connections the inner liner and the outer casing are both caulked with liberal amounts of sealant. Do not use any kind of tape or silicone other than that recommended in this manual, Mill Pac Sealant

## Installation Of Side Wall Venting

- To determine the minimum distance from the bottom of the fireplace to the center of the vent see page 7. Cut a hole through the wall allowing for a 11" x 11" (inside diameter) in combustible walls for wall thimble or an 8" diameter hole in a non-combustible wall (See Figure 2).
- For the clearance to combustible above a 90 degree bend see page 12.
- Select the approximate vent length, precise measurements are not needed as your flex pipe can be expanded to twice its shipped length for ease of installation.
- To install wall thimble centre over 11" x 11" (inch) framing from both sides of wall and secure. Route flex vent pipe through wall thimble (See Figure 1).
- Before joining pipes, apply a bead of high temperature sealant (Mill Pac) to end of pipe. First attach the four inch (4") flue pipe to the vent termination with sealant, and secure with 4 screws provided. At this time make sure the spacer springs are attached to the (4") flex pipe as required. Then attach the seven inch (7") pipe by the same method.
- Mount vent termination and seal to wall using caulking around the wall thimble to weather proof. After installing the vent termination, double check to make sure the pipe extends properly through wall thimble and into vent termination.
- Before joining pipes to fireplace flue, apply a bead of high temperature sealant (Mill Pac) to end of pipe. First attach the four inch (4") flue pipe to fireplace with Mill Pac sealant to the flue pipe and secure with 4 screws provided. At this time verify that the spacer springs are attached properly to the (4") flex pipe as required. Then attach the seven inch (7") pipe by the same method.
- Support horizontal pipes every two (2) feet (61 cm) with metal strap bands. Re-check fireplace to make sure it is levelled and properly positioned and secured.
- Support vertical pipes to maintain a minimum of 1" or greater clearance to combustibles with metal strapping bands.
- If finishing the outside wall with vinyl or wood siding it is recommended that a Siding Shield be installed, Part Number ZDVSSLR.

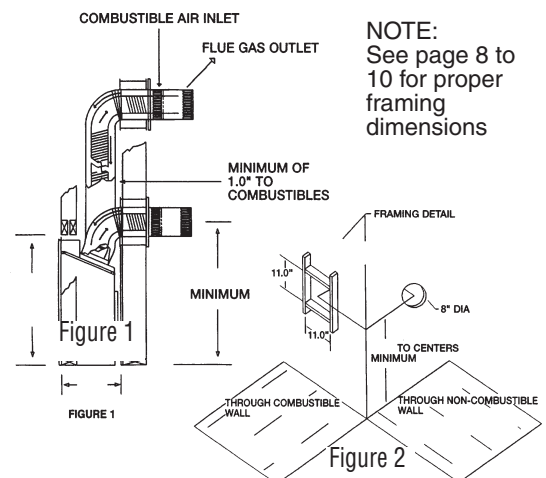

Note when using SIMPSON DURAVENT ADAPTER (ZDV DFA) the fireplace clearances from the back standoff is one inch, thus increasing the framing depth to 15".

**Venting Routes And Components**

Since it is very important that the vent system maintain its balance between the combustion air intake and the flue gas exhaust, certain limitations as to vent configurations apply and must be strictly adhered to.

The table showing the relationship between vertical and horizontal side wall venting will help to determine the various vent lengths.

The maximum horizontal run with the 90 degree bend at the fireplace flue outlet is 4 ft/122cm (Figure #1). The maximum horizontal run is 20 ft (6.1 m) when the vertical run is 7 ft/2.1m (Figure #2). Note: 1/4" vertical rise is required for every 12" of horizontal run.

The maximum number of 45 degree bends per side wall installation is two (2) in the horizontal run and then you must reduce the length of the horizontal by 18 inches for each 45 degree bend.

The maximum vertical run is 40 ft/12.2 meters.

**Special Note:** For each 45 degree bend installed in the horizontal run, the length of the horizontal run must be reduced by 18" (45cm). This does not apply if the 45 degree bends are installed on the vertical part of the vent system.

**Example:** If according to the table, the length of the horizontal run is 10 feet, and two 45 degree bends are required, the horizontal run length must be reduced to 7 feet.

2 additional 90° bends or equals are allowed. The horizontal run must be reduced by 36" per each 90° bend, or 18" per each 45° bend.

**Important:** Always locate the fireplace in such a way that a minimum of offsets and/or horizontal runs are required. 1/4" vertical rise is required for every 12" horizontal run.

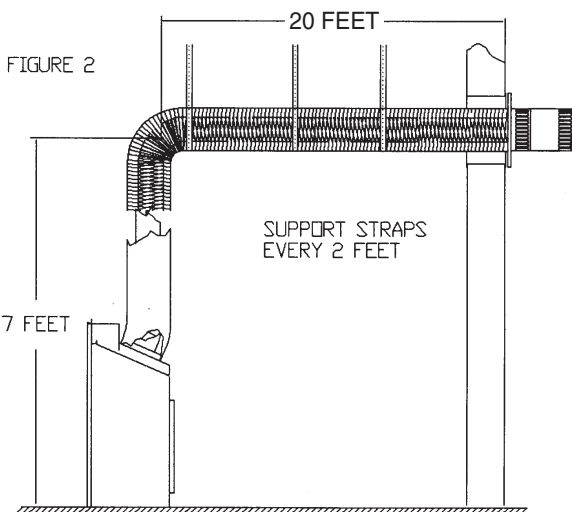
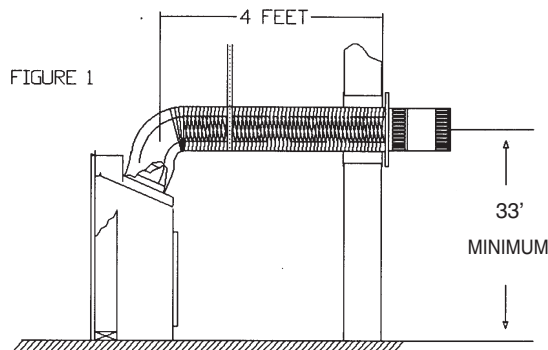

**How To Use The Vent Table**

1. Determine the height of the system and the number of bends required.
2. Having determined the vertical distance determine the maximum horizontal section allowed.
3. Vent table has been established for 90° horizontal/vertical runs. With use of flex pipe distance not having 90° bends will not fall into vent table standards. See Fig. B.

**Venting Table From Bottom of Fireplace**

for venting to a maximum of 40 ft. (12.2 meters)

Total Vertical		Max Total Horizontal	
Feet	Meters	Feet	Meters
4	1.2	5	1.5
5	1.5	8	2.4
6	1.8	12	3.7
7	2.1	20	6.1
8	2.4	20	6.1
9	2.7	20	6.1
10	3.0	20	6.1
11	3.4	20	6.1
12	3.7	20	6.1
13	4.0	20	6.1
14	4.3	20	6.1
15	4.6	20	6.1
16	4.9	20	6.1
17	5.2	20	6.1
18	5.5	20	6.1
19	5.8	20	6.1
20	6.1	20	6.1
25	7.5	15	4.6
30	9	10	3.0
40	12.2	0	0

Example A:

If the vertical dimension from the floor of the fireplace is 6ft, the horizontal run to the wall flange of the vent termination must not exceed 12ft.

**NOTE:** The final location of the fireplace must be such that the horizontal vent dimensions fall within those stated on the graph. The Maximum Vertical vent run is 40ft. (12.2 meters).

**Important:** Minimum clearance between vent pipes and combustible materials is 1 inch (25mm).

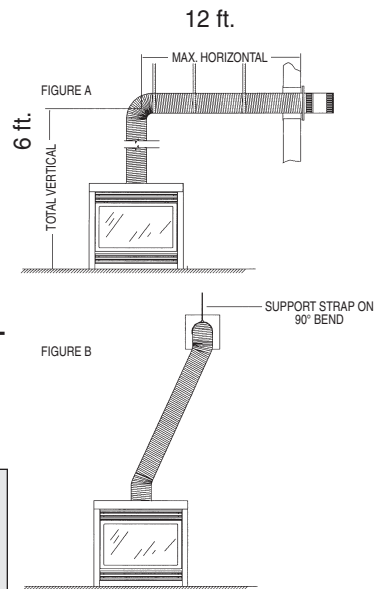

It is recommended for **Propane Horizontal Installations** that the venting should be a minimum of one foot vertical off the flue before the elbow on any horizontal runs of one foot or greater. This allows for cleaner combustion and greatly reduces carboning and cleaning of glass. (Does not apply to Back Flue Models).

## Venting Straight Up Through Roof

1. An Attic Insulation Shield must be installed where the vent passes from a lower living space into an attic space where the chimney is not enclosed. It is designed to keep insulation materials away from the chimney. See Fig. 1.
2. When installing the Attic Insulation Shield where the chimney passes from a living space to an attic space, install the shield from below and nail in place using 1" spiral nails.
3. A fire stop must be installed on the bottom side of the joists when passing through a ceiling or floor. If an attic insulation shield is to be used, a fire stop is not required.

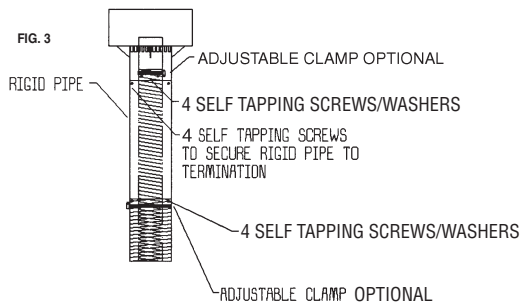
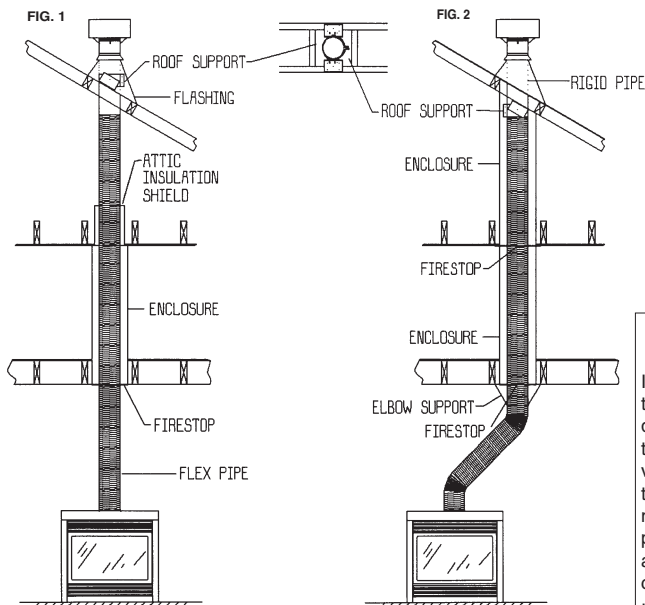

## Using Flex Bends

4. Avoid cutting joists by offsetting the flex pipe. See Fig. 2.
5. When using 45° bends a bend support is required directly above the highest bend.
6. When installing a bend in a joist area a minimum of 2½" clearance to combustibles to the top of bend must be maintained, sides and bottom of pipe, a 1" clearance to combustibles must be maintained. If running horizontal through an area a 1½" clearance to the top of the horizontal pipe must be maintained.
7. Maximum vertical height of system should not exceed 40 feet.
8. Use roof support and 7" rigid pipe at roof level. Flex not permitted within roof support.
9. When penetrating the roof a rigid 7" galvanized pipe must be used. Attach the 7" flex to the 7" rigid with high temperature sealant, secure with four screws assuring the flex and rigid pipe are secured. 4" flex pipe must be secured the same way with 4 screws but must penetrate the 4" flex and 4" section of termination. Attach 7" rigid pipe to 7" termination with sealant and screw with 4 sheet metal screws. (See Fig. 3).
10. Vertical termination clearance is 18" (inches) above the roof, measured from highest point of exit on the roof line.
11. Support vertical pipes to maintain minimum of one inch or greater clearances to combustibles.

## Roof Flashing

Ensure that you have the proper roof flashing by checking your roof pitch using a level and two rulers, or by using a roof pitch card.

See figure below.

Slide a Roof Flashing suitable to your roof slope over the vent. Place the edge of the flashing plate that will be on the higher part of the roof slope under the shingles. Both the sides and the lower edge lay on top of the shingles.

**NOTE: At the top edge of the flashing plate, lift the shingles and nail the plate to the roof deck, then cement the shingles to the plate with a suitable waterproof mastic.**

Ensure that the chimney is plumb. Square up the flashing plate and nail in place to the roof deck. Use 12 nails with neoprene washers or cover the heads with a suitable waterproof mastic.

Wrap the storm collar around the vent above the flashing. Secure the ends together loosely with nut and bolt supplied. Slide the collar down the vent until it comes in contact with the flashing. Tighten the bolt and seal the Storm Collar to the vent with a suitable waterproof non-combustible mastic.

The flashing and storm collar should be painted to match the roof shingles. This will extend its life and improve the appearance. Clean, prime and paint with suitable painting products.

## Vertical Venting in Cold Climates

In cold climate conditions where temperatures go below -10 degrees Celsius or 14 degrees Fahrenheit, we recommend that the chase be insulated and where the vent pipe enters into the attic space that the pipe be wrapped with an insulated mylar sleeve. This will increase the temperature of the vent and help the appliance to vent properly in cold weather conditions.

It is also important in vertical vented direct vent appliances that the appliance be operated daily during the winter months as this will help stop the Termination from freezing up. We recommend using a thermostat set at room temperature to allow the unit to cycle.

For IPI models it may be necessary to set the appliance to Standing Pilot mode to maintain heat in the cavity. The purpose of this procedure is to prevent cold air from penetrating the chimney and then onto the living space. Therefore, when the internal temperature is slightly elevated the fireplace is able to freely exhaust its combustion and hence making it easier to startup.

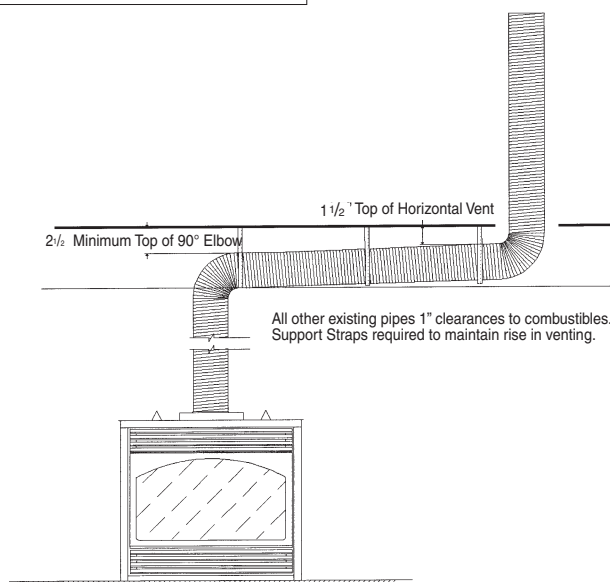
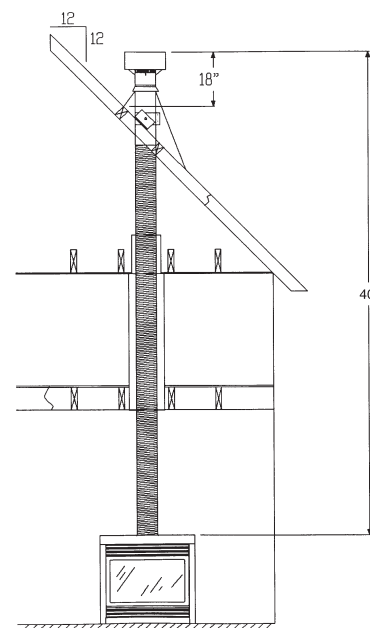

## Parts List

PART NO.	DESCRIPTION
<b>Fireplace Part Numbers</b>	
ZDV3320N (Millivolt) ZDV3320NE (IPI)	Fireplace Decorative Rated NG, Tempered Glass, 21,000 BTU
ZDV3320LP (Millivolt) ZDV3320LPE (IPI)	Fireplace Decorative Rated LP, Tempered Glass, 21,000 BTU
ZDV6000N (Millivolt) ZDV6000NE (IPI)	Zero Clearance Direct Vent Fireplace Natural Gas) 25,000 BTU
ZDV6000LP (Millivolt) ZDV6000LPE (IPI)	Zero Clearance Direct Vent Fireplace (Liquid Propane) 25,000 BTU
MQRB3328N (Millivolt) MQRB3328NE (IPI)	Zero Clearance Direct Vent Fireplace (Natural Gas) 25,000 BTU
MQRB3328LP (Millivolt) MQRB3328LPE (IPI)	Zero Clearance Direct Vent Fireplace (Liquid Propane) 25,000 BTU
MQRB3328NT (Millivolt) MQRB3328NTE (IPI)	Fireplace Decorative Rated NG, Tempered Glass, 21,000BTU
MQRB3328LPT (Millivolt) MQRB3328LPTE (IPI)	Fireplace Decorative Rated LP, Tempered Glass, 21,000BTU
<b>FIREPLACE REQUIREMENTS</b>	
<b>Log Sets or Rock Kits required for Fireplace</b>	
LOGC42	Log Set - 4 pce. - Classic Oak (ZDV3320)
LOGC43	Log Set - 4 pce. - Traditional Oak (ZDV3320)
LOGC44	Log Set - 8 pce. - Burnt Oak (ZDV3320)
LOGF5	Log Set -4 pce. Fibre Split Oak (ZDV6000)
LOGC5	Log Set -4 pce. Cast Split Oak (ZDV6000)
LOGC6	Log Set - 5 pce. - Cast Split Oak c/w Glowing Ember Rock Kit
MQROCK1	Rock Set Tan (ZDV3320/6000 & MQRB3328)
MQROCK2	Rock Set Natural (ZDV3320/6000 & MQRB3328)
MQROCK3	Rock Set Multi-Color (ZDV3320/6000 & MQRB3328)
MQRSP3	Rock Support Platform (ZDV3320)
MQRSP6	Rock Support Platform (ZDV6000)
MQEMBER	Glowing Embers 2 ea. (MQRB3328) option
MQRBD1	Driftwood and Rock 4 ea. (MQRB3328) option
MQG10W	Decorative Glass 1/2" White 10 lbs
MQG10B	Decorative Glass 1/4" Black 10 lbs
<b>Grills or CVCK (clean view circulating kit)(Required for each unit</b>	
Z33CVCK	CVCK(clean view circulating kit) no grill required
Z6GBA	Grill Kit - Classic Builder Antique Brass
Z6GBC	Grill Kit - Classic Builder Chrome
Z6GBP	Grill Kit - Classic Builder Polish Brass
VI30GBL	Grill Kit - Black
Z33PBL	Panel Grill Kit - Black

## Fireplace Accessories

PART NO.	DESCRIPTION
<b>MARQUIS WALL SURROUND COLLECTION</b>	
<b>Fireplace Wall Mount Finishing Surrounds for Z33CVCK Unit</b>	
MQ33SWFBL	Surround Flat Black (Coverage 35 5/16" H x 45 13/16" W)
MQ33SWFPW	Surround Flat Pewter (Coverage 35 5/16" H x 45 13/16" W)
<b>Marquis Wall Surround Accents (Four Pieces)</b>	
MQ36SWAKSB	Wall Surround Accents - Keystone Black
MQ36SWAKSC	Wall Surround Accents - Keystone Chrome
MQ36SWABBC	Wall Surround Accents - Band Black x 4, Chrome x 2
MQ36SWACB	Wall Surround Accents - Corner Black
<b>ACCESSORIES</b>	
<b>Surround Kits</b>	
Z6SAB	Surround - Antique Brass Coverage (31 3/16" H x 36 5/8" W)
Z6SCR	Surround - Chrome Coverage (31 3/16" H x 36 5/8" W)
Z6SPB	Surround - Polish Brass Coverage (31 3/16" H x 36 5/8" W)
Z33SLAB	Surround Slim Line - Antique Brass Coverage (30 7/8" H x 33 7/8" W)
Z33SLCR	Surround Slim Line - Chrome Coverage (30 7/8" H x 33 7/8" W)
Z33SLPB	Surround Slim Line - Polish Brass Coverage (30 7/8" H x 33 7/8" W)
Z33SLBL	Surround Slim Line - Gun Metal Black Coverage (30 7/8" H x 33 7/8" W)
<b>Arch Door Frames</b>	
Z33ADDX	Arch Door Frame - Deluxe Black (352)
Z33ADTH	Arch Door Frame - Top Half Black (535T)
Z33ADDA	Arch Door Frame - Double Arch Black (354)
Z33ADDD	Arch Door Frame - Double Door Arch Black (355)
Z6ADBL	Arch Door Frame - Black
Z6ADAB	Arch Door Frame - Antique Brass
Z33ADCR	Arch Door Frame - Chrome
Z6ADPB	Arch Door Frame - Polish Brass
<b>Designer Doors for 33" Fireplaces - Operative</b>	
Z33DDA1BL	Designer Door Arch - Series 1 - Black
Z33DDTA1A	Trim - Antique for Designer Arch - Series 1
Z33DDTA1C	Trim - Chrome for Designer Arch - Series 1
Z33DDTA1P	Trim - Polish for Designer Arch - Series 1
Z33DDS1BL	Designer Door Straight - Series 1 - Black
Z33DDS2BL	Designer Door Straight - Series 2 - Black
Z33DDS3BL	Designer Door Straight - Series 3 - Black
Z33DDTS1A	Trim - Antique for Designer Straight - Series 1
Z33DDTS1C	Trim - Chrome for Designer Straight - Series 1
Z33DDTS1P	Trim - Polish for Designer Straight - Series 1
<b>Child Safety Screens</b>	
Z33CSS	Child Safety Screen - 33" DV Fireplaces
<b>Liners</b>	
Z33RLC	Refractory Brick Liner (3 pce) (ZDV3320/6000)
MQRB33PB	Porcelain Bottom (MQRB3328)
MQRB33PL	Porcelain Liner (3 pce.) (MQRB3328)

<b>PART NO.</b>	<b>DESCRIPTION</b>
<b>Other Accessories</b>	
Z33FK	Fan Kit w/Variable Wall Mount Speed Control (Temperature Sensing)
Z1MT	Thermostat Millivolt Wall Mount
Z8OPT	Thermostat Programmable Digital Millivolt Wall Mount (1F80-40)
Z1RC	Remote Control Millivolt (On/Off with LED) (Model I)
ZART	Remote Control Thermostat Millivolt (Model K)
DCHS	Remote Control Heatshield
RMCBN	Remote Control - Basic - Natural Gas (On/Off, Hi/Lo Flame Adjustment, Millivolt Only)
RMCBP	Remote Control - Basic - Liquid Propane (On/Off, Hi/Lo Flame Adjustment, Millivolt Only)
VLBIT4	Log Bits - Large 4 Piece Kit
VLBIT6	Log Bits - Small 6 Piece Kit

## Kingsman Fireplace Venting

### Catalog

#### Number Description

##### Replacement Burner Assembly (Millivolt)

3320-BNGSI	Burner Assembly - Natural Gas c/w Valve System (ZDV3320N)
3320-BLPSI	Burner Assembly - Liquid Propane c/w Valve (ZDV3320LP)
6000-BNGSI	Burner Assembly - (NG) c/w Valve System
6000-BLPSI	Burner Assembly (LP) - c/w Valve System
3328-RBNGSI	Burner Assembly (NG) c/w Valve System (25,000 BTU)
3328-RBLPSI	Burner Assembly (LP) c/w Valve System (25,000 BTU)
3328-RBNGTSI	Burner Assembly (NG) c/w Valve System (21,000 BTU)
3328-RBLPTSI	Burner Assembly (LP) c/w Valve System (21,000 BTU)

##### Conversion Kit (Sit Valve Only)

3320-CKLP	LP Conversion Kit (Millivolt) (ZDV3320LP/MQRB3328LPT)
3320-CKNG	NG Conversion Kit (Millivolt) (ZDV3320N/MQRB3328NT)
3320-CKLPI	LP Conversion Kit (IPI) (ZDV3320LP/MQRB3328LPT)
3320-CKNGI	NG Conversion Kit (IPI) (ZDV3320N/MQRB3328NT)
6000-CKLP	LP Conversion Kit (Millivolt) (ZDV6000LP/MQRB3328LP)
6000-CKNG	NG Conversion Kit (Millivolt) (ZDV6000N/MQRB3328N)
6000-CKLPI	LP Conversion Kit (IPI) (ZDV6000LP/MQRB3328LP)
6000-CKNGI	NG Conversion Kit (IPI) (ZDV6000N/MQRB3328N)
3328RBT-CKLP	LP Conversion Kit (Millivolt) (MQRB3328T)
3328RBT-CKNG	NG Conversion Kit (Millivolt) (MQRB3328T)
3328RBT-CKLPI	LP Conversion Kit (IPI) (MQRB3328T)
3328RBT-CKNGI	NG Conversion Kit (IPI) (MQRB3328T)
3328RB-CKLP	LP Conversion Kit (Millivolt) (MQRB3328)
3328RB-CKNG	NG Conversion Kit (Millivolt) (MQRB3328)
3328RB-CKLPI	LP Conversion Kit (IPI) (MQRB3328)
3328RB-CKNGI	NG Conversion Kit (IPI) (MQRB3328)

### Catalog

#### Number Description

##### Valve System Parts

(If Serial Number is less than ZDV3320LP - 6832 / ZDV3320N-6707)  
(If Serial Number is LESS than: ZDV6000LP - 6722 / ZDV6000N -6819)

1000-P136WR	Thermopile GOAI-524
1001-P035SI	Electrode Sparker 915.035 SIT
1001-P129SI	Thermocouple 290.129 SIT unified
1001-P157SI	Orifice Pilot LP 977.157 SIT
1001-P159SI	Orifice Pilot NG 977.159 SIT
1001-P508SI	HT Cable 16
1001-P633SI	Valve Nova LP Hi/Lo 0820633
1001-P634SI	Valve Nova NG Hi/Lo 0820634
1001-P605SI	Pilot Burner LP 190.605 unified SIT
1001-P606SI	Pilot Burner NG 190.606 unified SIT

##### Valve System Parts - New Top Convertible SIT-(MQR3328)

(If Serial Number is GREATER than or equal to above)

1000-P136WR	Thermopile GOAI-524
1001-P069SI	Electrode Sparker 915.069 TC SIT
1001-P216SI	Thermocouple 290.216 TC SIT
1001-P165SI	Orifice Pilot NG 977.165 TC SIT
1001-P167SI	Orifice Pilot LP 977.167 TC SIT
1001-P508SI	HT Cable 16
1001-P633SI	Valve Nova LP Hi/Lo 0820633/651
1001-P634SI	Valve Nova NG Hi/Lo 0820634/652
1001-P713SI	Pilot Burner LP 199.713 TC SIT
1001-P714SI	Pilot Burner NG 199.714 TC SIT

##### Valve System Parts - IPI System

##### Electronic Ignition/Remote Control IPI

EGTRC	Remote Control IPI (Thermostat)
EGTMRCN	Remote Control IPI (Thermostat/Modulating - NG)
EGTMRCP	Remote Control IPI (Thermostat/Modulating - LP)
EGTFRCN	Remote Control IPI (Thermostat/Modulating/Fan - NG)
EGTFRCP	Remote Control IPI (Thermostat/Modulating/Fan - LP)

##### Electronic Ignition Replacement Parts IPI

1002-P001si	Valve IPI (NG; ON/OFF)
1002-P002si	Valve IPI (LP; ON/OFF)
1006-P002si	Valve IPI (NG; Hi/Lo)
1006-P603si	Valve IPI (LP; Hi/Lo)
1002-P047si	Pilot Assembly (LP)
1002-P033si	Pilot Assembly (NG)
1002-P089si	Spark Electrode (Long)
1002-P113si	Electrode Flame Sensor (Long)
1002-P302si	IPI Ignition Board
1002-P850si	AC Wall Adapter
1002-P12BH	Battery Pack
1002-P912si	Wiring Harness
1002-P166si	Orifice Pilot (NG #62)
1002-P168si	Orifice Pilot (LP #35)
1002-P013si	Stepper Motor (NG)
1002-P012si	Stepper Motor (LP)
1002-P016is	Hi/Lo Regulator (NG)
1002-P014si	Hi/Lo Regulator (LP)

# Kingsman Fireplace Venting

## Catalog

### Number Description

#### Miscellaneous Parts

1000-150GE	#SILICONE GE RED IS806 #736
1000-150MP	#HI-TEMP MILL PAC SEALANT 840099
1000-214	#PIEZO-IGNITER 1244-17 MARK 21
1000-215	#PAL NUT (18MMX1.5MM)BLK (1364.03)
1000-218	#SWITCH IVORY (1451/001)
1000-227	#COVER IVORY (86001/001)
1000-255	#ORIFICE BRASS - (State Size)
1000-EMBER	#GLOWING MOON ROCK
6000-130	#EXPLOSION FELT GASKET
2000-080	#THERMODISC 2450 (For Blower)
6000-P930	#BLOWER MOTOR QLN65/1800
1000-085	#CONTROL VARIABLE SPEED KBWC-13BV
1000-306	THERMALCORD - ADHESIVE BACK FOR DOOR FRAME
6000-150	CERAMIC GLASS - ZDV6000/3320/MQRB3328
6000-151	TEMPERED GLASS - ZDV3320/MQRB3328T
C6GEK	Grate & Ember Plates for Field Conversion for LOGC6 Log Set - c/w Ember Support Plates & Grate Bar For 6000, 4 - 8X18 DT Screws
ZDVHSK	Horizontal Vent Starter Kit - 3 FT Length Horizontal Vent Termination, Wall Thimble, 36" Flex Pipe, Mill Pac, 12 screws/washers.
ZDVHKS5	Horizontal Vent Starter Kit - 5 FT Length Horizontal Vent Termination, Wall Thimble, 60" Flex Pipe, Mill Pac, 12 screws/washers.
FDVVT40	Vertical Vent Termination converts from 15'-40' to under 15'
FDVHT	Horizontal Vent Termination
FDVHSQ	Horizontal Square Termination
ZDVST	Horizontal Snorkel Termination (34" Tall, 24" Center to Center)
FDVHSCU	Safety Cage for Horizontal Termination
ZDVAIS	Attic Insulation Shield
ZDIVOS	Offset Support
ZDVFS	Firestop Spacer
ZDVRS	Roof Support
ZDV48GP	Galvanized Pipe 7" Dia. x 48" (Vertical Installations)
ZDVAAF	Flashing 7" c/w Storm Collar (1/12 to 7/12)
ZDVAF2	Flashing 7" c/w Storm Collar (8/12 to 12/12)
ZDVAF3	Flashing 7" c/w Storm Collar Flat
ZDV7SC	Storm Collar 7"
ZDVWT	Wall Thimble (Horizontal Venting)
ZDVFK5	Flex Kit (4" & 7" Dia.)x 2.5' (Unexpanded) 5' Expanded
ZDVFK8	Flex Kit (4" & 7" Dia.)x 4' (Unexpanded) 8' Expanded
ZDVFK20	Flex Kit (4" & 7" Dia.) 10' (Unexpanded) 20' Expanded *Kits are complete with spring stand-offs, silicone, 12 screws/washers.
ZDV4FC	Flex Connector 4" Diameter
ZDV7FC	Flex Connector 7" Diameter
ZDV4SS	Spring 4" Standoff Spacer
ZDV DFA	Dura-Vent Fireplace Adapter

## Catalog

### Number Description

#### Miscellaneous Parts

ZDVHKSQ	Horizontal Square Termination Vent Starter Kit - 3 FT Length Horizontal Vent Termination, Wall Thimble, 36" Flex Pipe, Mill Pac
ZDVHKSQ5	Horizontal Square Termination Vent Starter Kit - 5 FT Length Horizontal Vent Termination, Wall Thimble, 60" Flex Pipe, Mill Pac
ZDVSSLR	Siding Shield - Large Return



## LIMITED LIFETIME WARRANTY

This Limited Lifetime Warranty applies only while the unit remains at the site of the original installation and only if the unit is installed inside the continental United States, Alaska, Hawaii, and Canada. The warranty applies only if the unit is installed and operated in accordance with the printed instructions and in compliance with applicable installation and building codes and good trade practices.

### BASIC ONE YEAR WARRANTY

During the first year after installation, we will provide a replacement for any component part of your unit found to be defective in materials or workmanship, including labour costs. Repair work requires prior approval by Kingsman, labour costs are based on a predetermined rate schedule and any repair work must be done through an authorized Kingsman dealer.

### LIMITED LIFETIME WARRANTY

The heat exchanger, combustion chamber and burner of every Kingsman product excluding the Outdoor Firepit are warranted against materials or workmanship during the period the product is owned by the original owner. The part to be replaced must be returned to our distributor in exchange for the replacement part. Any labor, material, freight and/or handling charges associated with any repair or replacement pursuant to this Limited Lifetime Warranty will not be covered by this warranty.

### GENERAL TERMS

In lieu of providing a replacement part, we may, at our option, provide the distributor's component purchase price from us or a credit equal to the distributors component purchase price from us toward the purchase of any new unit which we distribute. If a credit is given in lieu of a replacement part, the rating plate from the unit being replaced must be submitted on a warranty claim, and the unit being replaced must be made available to our distributor for disposition.

In establishing the date of installation for any purpose, including determination of the starting date for the term of this Limited Lifetime Warranty, reasonable proof of the original installation date must be presented\*, otherwise the effective date will be based upon the date of manufacture plus thirty (30) days.

We will not be responsible for and you, the user, will pay for: (a) damages caused by accident, abuse, negligence, misuse, riot, fire, flood, or Acts of God (b) damages caused by operating the unit where there is a corrosive atmosphere containing chlorine, fluorine, or any other damaging chemicals (other than in a normal residential environment) (c) damages caused by any unauthorized alteration or repair of the unit affecting its stability or performance (d) damages caused by improper matching or application of the unit or the unit's components (e) damages caused by failing to provide proper maintenance and service to the unit (f) any expenses incurred for erecting, disconnecting or dismantling the unit (g) parts or supplies used in connection with service or maintenance (h) damage repairs, inoperation or inefficiency resulting from faulty installation or application (i) electricity or fuel costs or any increase in electricity or fuel cost whatsoever including additional or unusual use of supplemental electric heat.

We shall not be liable for any incidental, consequential, or special damages or expenses in connection with any use or failure of this unit. We have not made and do not make any representation or warranty of fitness for a particular use or purpose, and there is no implied condition of fitness for a particular use or purpose. We make no express warranties except as stated in this Limited Lifetime Warranty. No one is authorized to change this Limited Lifetime Warranty or to create for us any other obligation or liability in connections with this unit. Any implied warranties shall last for one year after the original installation. Some states and provinces do not allow the exclusion or limitation of incidental or consequential damages or do not allow limitations on how long an implied warranty or condition lasts, so the above limitations or exclusions may not apply to you. The provisions of this limited warranty are in additions to and not a modification of or subtraction from any statutory warranties and other rights and remedies provided by law.

Save this certificate. It gives you specific legal rights, and you may also have other rights which may vary from state to state and province to province.

In the event your unit needs servicing, contact your dealer or contractor who installed or serviced your unit. When requesting service, please have the model and serial number from each unit readily available. If your dealer needs assistance, the distributor is available for support and we, in turn support the distributor's efforts.

Fill in the installation date and model and serial numbers of the unit in the space provided below and retain this limited warranty for your files.

**Model No.** \_\_\_\_\_ **Serial No.** \_\_\_\_\_ **Date installed** \_\_\_\_\_

**Dealer or Contractor Name:** \_\_\_\_\_

\*To receive advantage of your warranty, you must retain the original records that can establish the installation date of your unit.