



AIR CONDITIONER

Wall Mounted type

DESIGN & TECHNICAL MANUAL

INDOOR



ASU24CL1

OUTDOOR



AOU24CL1

FUJITSU GENERAL LIMITED

1. INDOOR UNIT

**WALL MOUNTED TYPE :
ASU24CL1**

CONTENTS

1. INDOOR UNIT

1. FEATURE.....	01 - 01
2. WIRELESS REMOTE CONTROLLER.....	01 - 03
3. SPECIFICATIONS.....	01 - 05
4. DIMENSIONS.....	01 - 06
5. WIRING DIAGRAMS.....	01 - 07
6. CAPACITY TABLE.....	01 - 08
6-1. COOLING CAPACITY.....	01 - 08
7. FAN PERFORMANCE.....	01 - 09
7-1. AIR VELOCITY DISTRIBUTION.....	01 - 09
7-2. AIR FLOW.....	01 - 10
8. OPERATION NOISE.....	01 - 11
8-1. NOISE LEVEL CURVE.....	01 - 11
8-2. SOUND LEVEL CHECK POINT.....	01 - 12
9. ELECTRIC CHARACTERISTICS.....	01 - 13
10. SAFETY DEVICES.....	01 - 14
11. EXTERNAL INPUT & OUTPUT.....	01 - 15
11-1. EXTERNAL INPUT.....	01 - 15
11-2. EXTERNAL OUTPUT.....	01 - 16
12. FUNCTION SETTING.....	01 - 17
12-1. INDOOR UNIT.....	01 - 17
13. OPTIONAL PARTS.....	01 - 19

1. FEATURE

■ MODEL ASU24CL1 / AOU24CL1



■ FEATURES

● ALL DC



DC fan motor

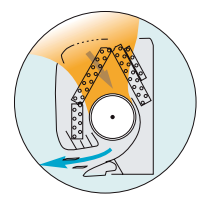

High efficiency layout

Large air flow and quiet operation by new air flow path

- a DC fan motor**
- b PAM control**
PAM technology makes a compressor more powerful.
- c DC compressor**
More compact compared with conventional model

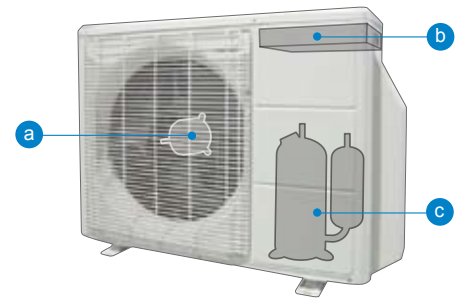

Front view

● Super quiet

Air flow mode can be set in 4 steps and more detailed air flow setting is possible.

● Easy maintenance

Easy maintenance and always clean. Troublesome maintenance has been made easy. Since the front panel is easy to remove, maintenance is also easy.

● Power diffuser

“Healthy horizontal air flow” does not blow cool air directly at the occupants in the room.

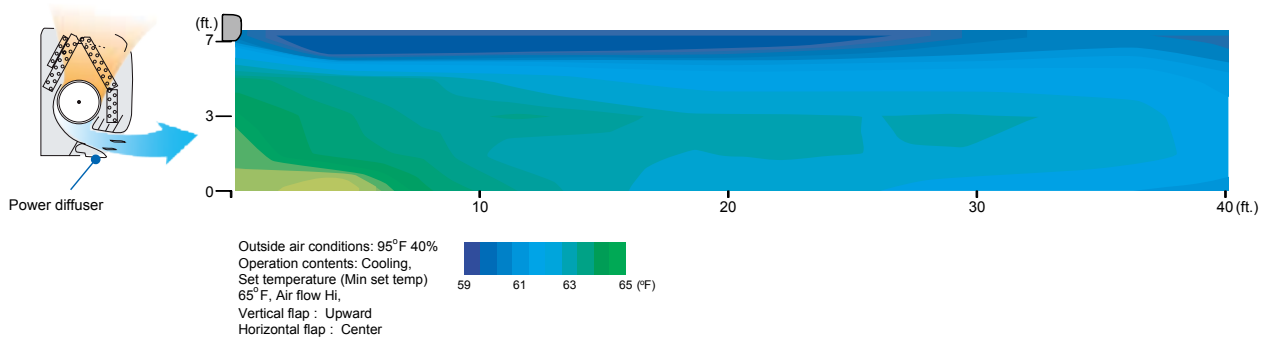

● Low outdoor air temperature cooling correspondence

Corresponds to cooling operation at 14°F (-10°C) outdoor air temperature

● Corresponds to maximum 98 feet (30m) long piping

● Air conditioner filter features

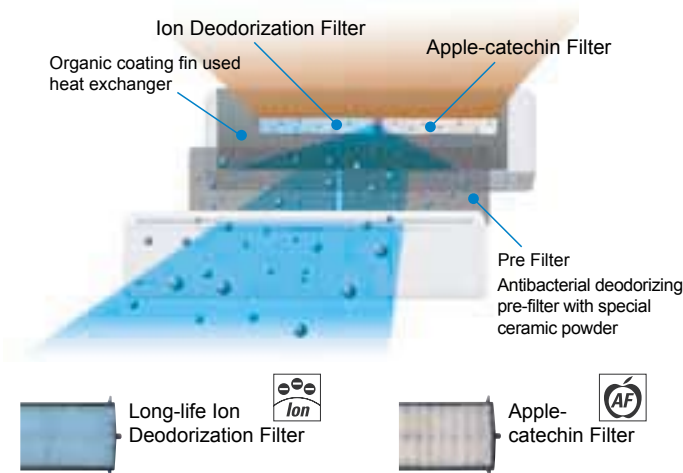

● Blue fin heat exchanger

Corrosion-resistance of the heat exchanger even in coastal areas has been improved by blue fin treatment of the outdoor unit heat exchanger.



2. WIRELESS REMOTE CONTROLLER

■ FEATURES



- * Four kinds of timer setup (On / Off / Program / Sleep) are possible.
- * Four kinds of timers. Easy operation.
- * Easy to change transmission code (4 patterns) by button operation.

● Built-in timers

Select from four different timer programs (On / Off / Program / Sleep).

● Program timer

The program timer operates the on and off timer once within a 24 hour period.

● Sleep timer

The sleep timer function automatically corrects the temperature thermostat setting according to the timer setting to prevent excessive cooling while sleeping.

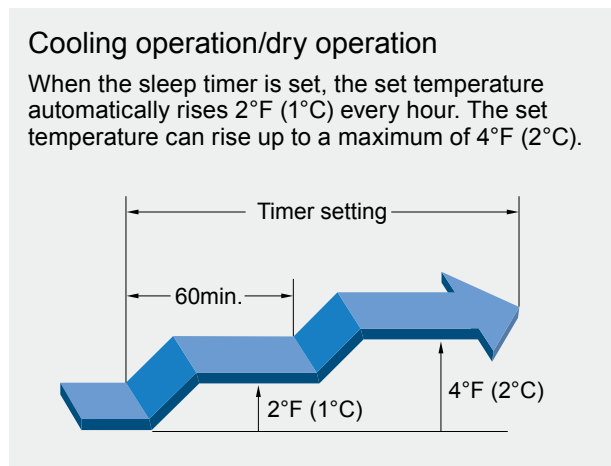

● Switching remote controller signal code

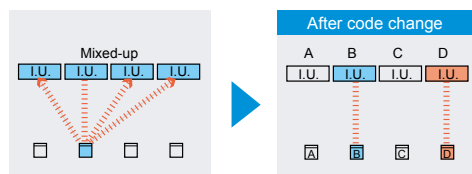

- Code selector switch eliminates unit being wrongly switched. (Up to 4 codes can be set.)

*I.U.=Indoor unit

FUNCTIONS

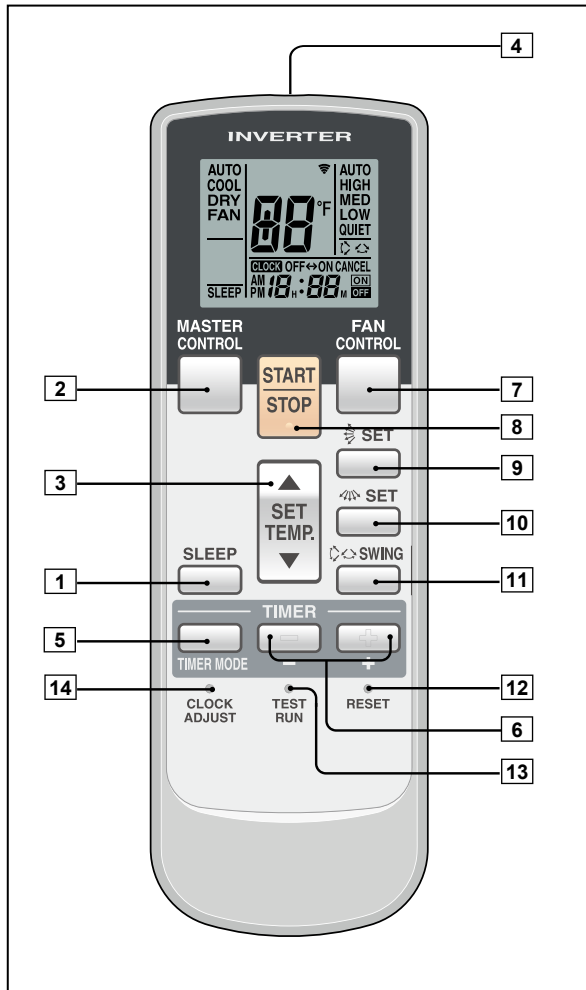

- 1 SLEEP button
- 2 MASTER CONTROL button
- 3 SET TEMP. button (▲ / ▼)
- 4 Signal transmitter
- 5 TIMER MODE button
- 6 TIMER SET (+ / -) button
- 7 FAN CONTROL button
- 8 START/STOP button
- 9 SET button (Vertical)
- 10 SET button (Horizontal)
- 11 SWING button
- 12 RESET button
- 13 TEST RUN button

- This button is used when installing the air conditioner, and should not be used under normal conditions, as it will cause the indoor unit's thermostat function to operate incorrectly.
- If this button is pressed during normal operation, the indoor unit will switch to test operation mode, and the Indoor Unit's OPERATION Indicator Lamp and TIMER Indicator Lamp will begin to flash simultaneously.
- To stop the test operation mode, press the START/STOP button to stop the air conditioner.

14 CLOCK ADJUST button

15 Remote controller display

16 Transmit indicator

17 Clock display

18 Operating mode display

19 Timer mode display

20 Fan speed display

21 Temperature set display

22 Sleep display

23 Swing display

Display panel

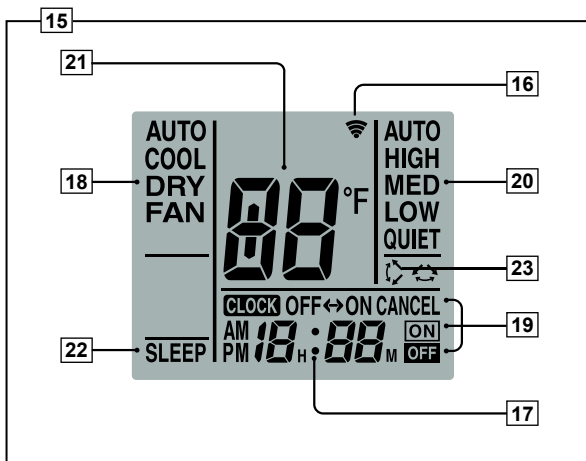

Functions will be different due to type of indoor unit.
For details, please see operation manual.

To facilitate explanation, the accompanying illustration has been drawn to show all possible indicators; in actual operation, however, the display will only show those indicators appropriate to the current operation.

SPECIFICATION

SIZE [H x W x D]	in. (mm)	6-11/16 x 2-7/32 x 3/4 (170 x 56 x 19)
WEIGHT [w/o batteries]	oz. (g)	3 (85)
ACCESSORY		Holder

3. SPECIFICATIONS

Type				WALL MOUNTED		
Model name				COOLING ONLY INVERTER		
Power source				ASU24CL1		
Available voltage range				202/230V ~ 60Hz		
Available voltage range				187-253V ~ 60Hz		
Capacity	Cooling	Rated	kW (W)	7.03		
			BTU/h	24,000		
		Min.-Max.	kW	0.9 - 7.3		
			BTU/h	3,100 - 25,000		
Input power	Cooling	Rated	kW	2.40		
		Min.-Max.		0.11 - 2.50		
Current	Cooling	Rated	A	10.5		
		Max.*		11.5		
EER	Cooling	W / W (BTU / hW)	2.93 (10.0)			
SEER	Cooling	(BTU / hW)	17.5			
SENSIBLE CAPACITY	Cooling	kW	5.33			
POWER FACTOR	Cooling	%	99			
Moisture removal			pints/h (l/h)	6.3 (3.0)		
Fan	Airflow rate	Cooling	High	CFM (m ³ /h)	659 (1120)	
			Med		530 (900)	
			Low		436 (740)	
			Quiet		365 (620)	
	Type × Q'ty	Cross flow fan × 1				
Motor output			W	40		
Sound pressure level	Cooling		High	dB(A)	48	
			Med		42	
			Low		37	
			Quiet		33	
Heat exchanger type	Dimensions (H × W × D)		in. mm	Main: 15-7/8 × 33-3/4 × 1-1/16 (378 × 832 × 26.6) Sub: 3-5/16 × 33-3/4 × 17/32 (84 × 832 × 13.3)		
	Fin pitch		FPI	Main: 21, Sub: 18		
	Rows × Stages			Main: 2 × 18, Sub1: 1 × 4, Sub2: 1 × 4		
	Pipe type			Copper		
	Fin type			Aluminium		
Enclosure	Material		Polystyrene			
	Color		WHITE Approximate color of MUNSELL N 9.25/			
Dimensions (H×W ×D)	Net			mm	320 × 998 × 228	
				inch	12-5/8 × 39-1/4 × 9	
	Gross			mm	319 × 1090 × 429	
				inch	12-3/5 × 42-15/16 × 16-7/8	
Weight	Net			lb.(kg)	31 (14)	
	Gross				40 (18)	
Connection pipe	Size	Liquid	inch (mm)	Ø1/4 (Ø6.35)		
		Gas		Ø5/8 (Ø15.88)		
	Method		Flare			
Operation range	Cooling			°F (°C)	60 to 90 (18 to 32)	
				%RH	80 or less	
Remote controller type				Wireless		
Drain pipe	Material		PVC			
	Size		mm (in)	Outer diameter: 28 (1-3/32) Inner diameter: 16 (5/8)		

Note :

Specifications are based on the following conditions.

Cooling : Indoor temperature of 80 °F (26.7°C)DB/67 °F (19.4°C)WB and outdoor temperature of 95 °F (35°C)DB/75 °F (23.9°C)WB.

Pipe length : 25ft. (7.5 m), Height difference : 0 m.(Outdoor unit - Indoor unit)

* The maximum current is the total current of indoor unit and outdoor unit.

4. DIMENSIONS

■ MODEL: ASU24CL1

Unit : in. (mm)

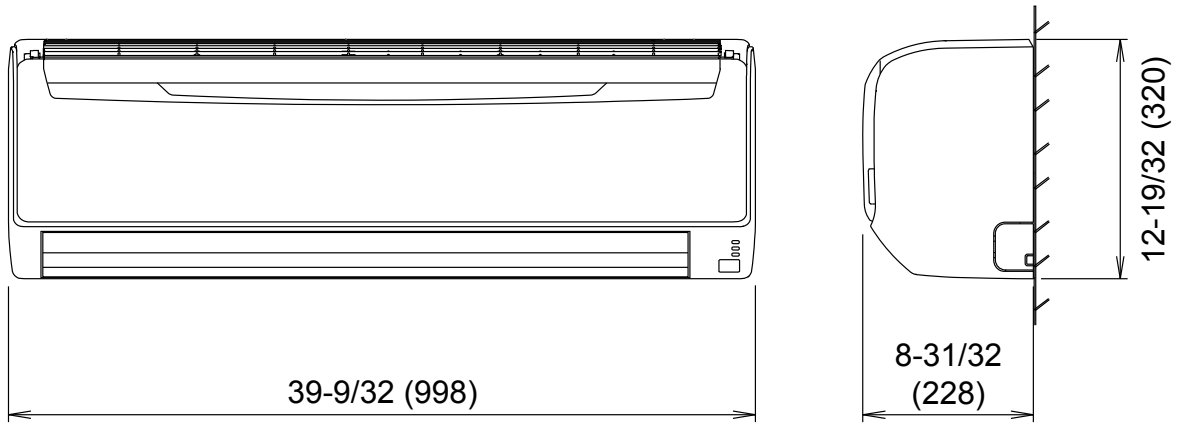

■ INSTALLATION PLACE

Unit : in. (mm)

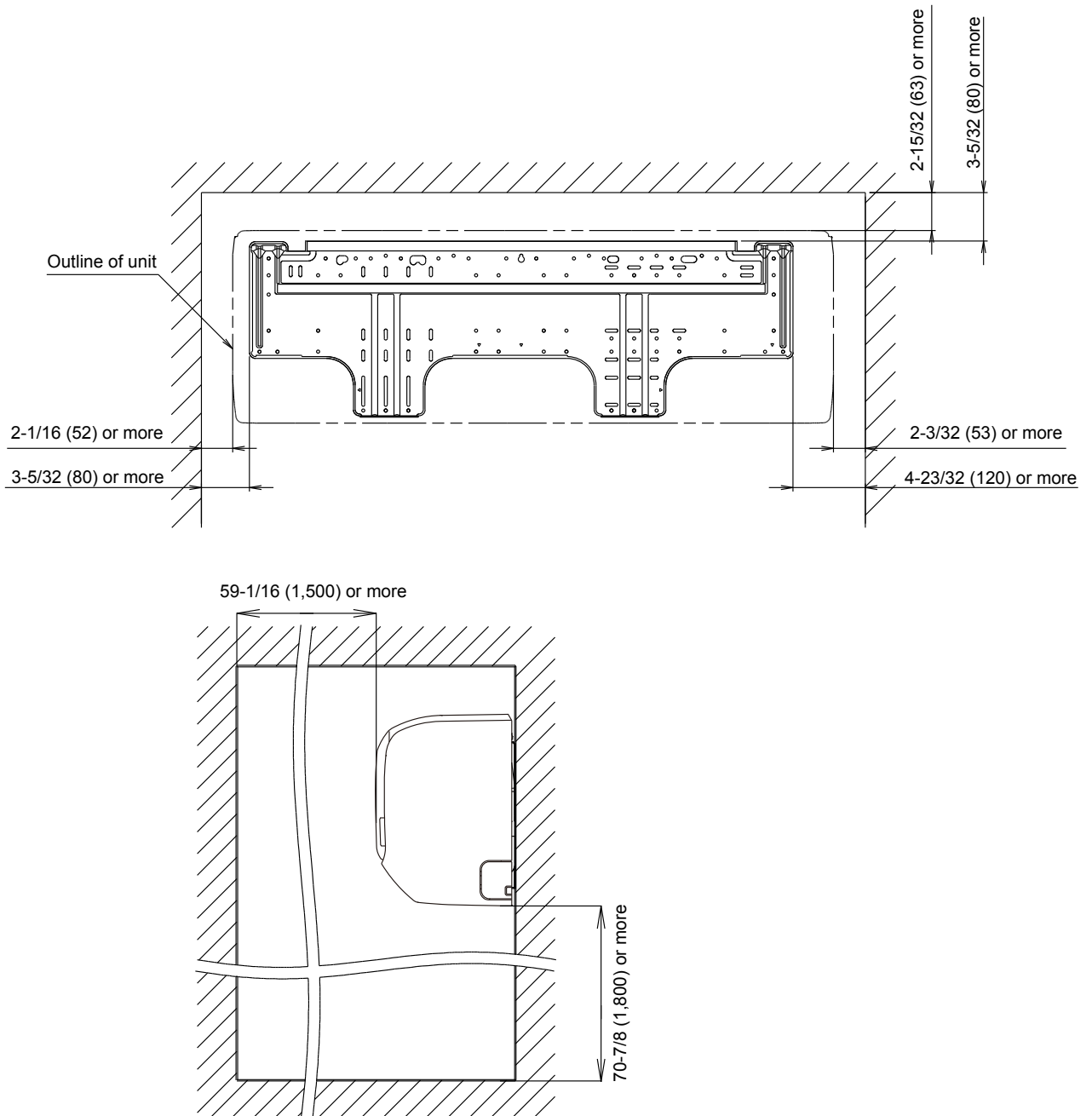

5. WIRING DIAGRAMS

MODEL: ASU24CL1

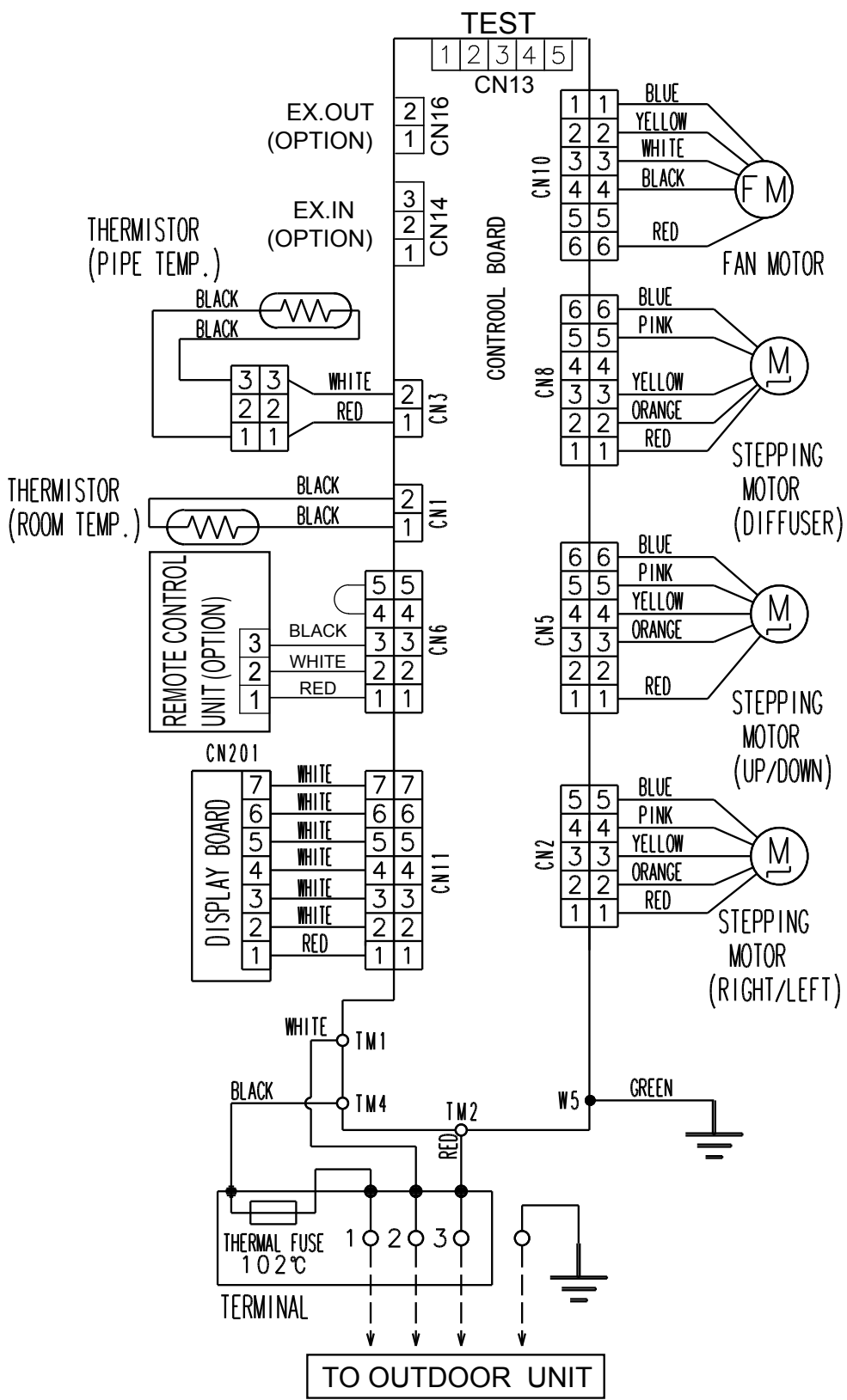

6. CAPACITY TABLE

6-1. COOLING CAPACITY

■ MODEL: ASU24CL1

AFR	659
-----	-----

		Indoor temperature																	
		64			70			75			80			85			90		
		54			60			63			67			71			73		
Outdoor temperature	°FDB	TC	SHC	PI	TC	SHC	PI	TC	SHC	PI	TC	SHC	PI	TC	SHC	PI	TC	SHC	PI
	15.0	19.7	15.7	1.04	21.9	15.8	1.05	22.7	17.1	1.05	24.9	18.6	1.07	26.4	18.5	1.07	27.9	19.7	1.08
	67	19.7	15.3	1.20	21.1	15.4	1.22	21.8	16.7	1.23	24.0	18.1	1.25	25.4	18.1	1.26	26.9	19.3	1.27
	77	21.0	17.9	1.88	23.4	18.0	1.91	24.2	19.6	1.92	26.5	21.2	1.95	28.1	21.2	1.97	29.7	22.5	1.99
	87	20.0	16.7	2.10	22.3	16.8	2.13	23.0	18.2	2.14	25.3	19.8	2.17	26.8	19.7	2.20	28.3	21.0	2.22
	95	19.0	15.3	2.32	21.1	15.4	2.35	21.8	16.8	2.36	24.0	18.2	2.40	25.4	18.1	2.43	26.9	19.3	2.45
	104	17.0	12.8	2.50	19.0	12.8	2.54	19.6	14.0	2.55	21.6	15.1	2.59	22.9	15.1	2.62	24.2	16.1	2.64
	115	16.0	11.3	2.53	17.8	11.4	2.57	18.5	12.4	2.58	20.3	13.5	2.62	21.5	13.4	2.64	22.7	14.3	2.67

AFR: Air flow rate (CFM)
 TC: Total capacity (kBTU)
 SHC: Sensible heat capacity (kBTU)
 PI: Power input (kW)

AFR	18.7
-----	------

		Indoor temperature																	
		17.8			21.1			23.9			26.7			29.4			32.2		
		12.2			15.6			17.7			19.4			21.7			22.8		
Outdoor temperature	°CDB	TC	SHC	PI	TC	SHC	PI	TC	SHC	PI	TC	SHC	PI	TC	SHC	PI	TC	SHC	PI
	15.0	5.77	4.59	1.04	6.42	4.62	1.05	6.65	5.02	1.05	7.31	5.44	1.07	7.74	5.41	1.07	8.18	5.77	1.08
	19.4	5.55	4.48	1.20	6.18	4.51	1.22	6.39	4.90	1.23	7.02	5.31	1.25	7.44	5.30	1.26	7.87	5.64	1.27
	25.0	6.14	5.24	1.88	6.84	5.27	1.91	7.08	5.74	1.92	7.78	6.22	1.95	8.24	6.20	1.97	8.71	6.61	1.99
	30.6	5.85	4.88	2.10	6.52	4.91	2.13	6.74	5.35	2.14	7.41	5.79	2.17	7.85	5.78	2.20	8.30	6.15	2.22
	35.0	5.55	4.49	2.32	6.19	4.52	2.35	6.40	4.92	2.36	7.03	5.33	2.40	7.45	5.31	2.43	7.87	5.66	2.45
	40.0	4.99	3.74	2.50	5.56	3.77	2.54	5.75	4.10	2.55	6.32	4.44	2.59	6.70	4.43	2.62	7.08	4.72	2.64
	46.1	4.69	3.32	2.53	5.23	3.34	2.57	5.41	3.64	2.58	5.94	3.94	2.62	6.30	3.93	2.64	6.65	4.19	2.67

AFR: Air flow rate (m³/min)
 TC: Total capacity (kW)
 SHC: Sensible heat capacity (kW)
 PI: Power input (kW)

7. FAN PERFORMANCE

7-1. AIR VELOCITY DISTRIBUTION

■ MODEL: ASU24CL1

Note:
Fan speed : HIGH
Operation mode : FAN

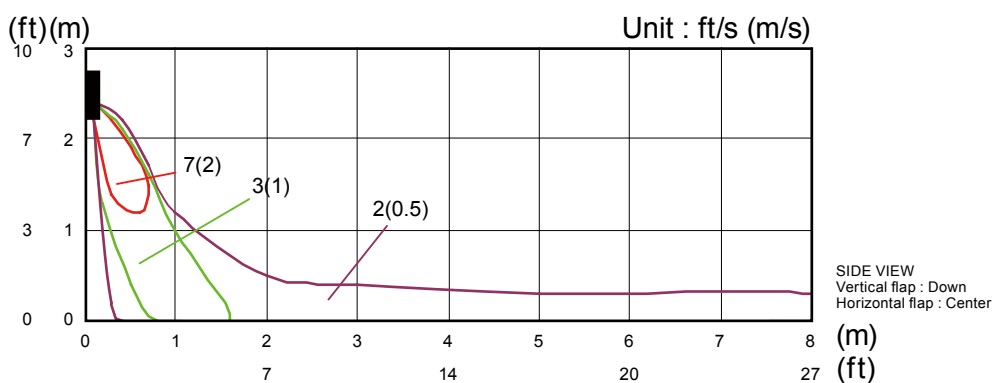
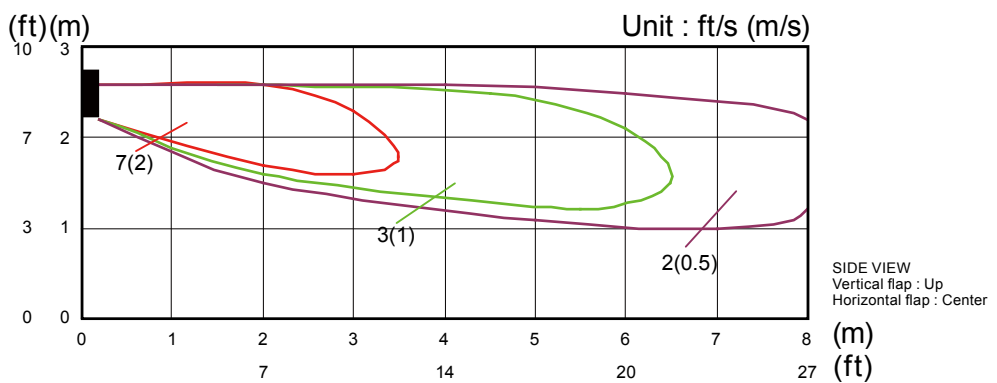
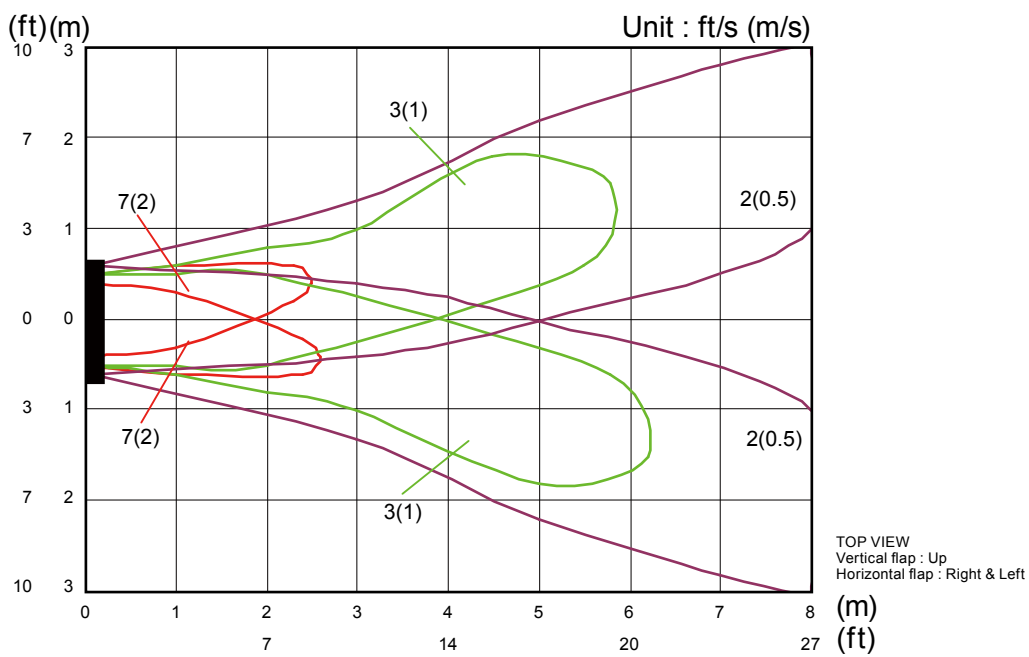
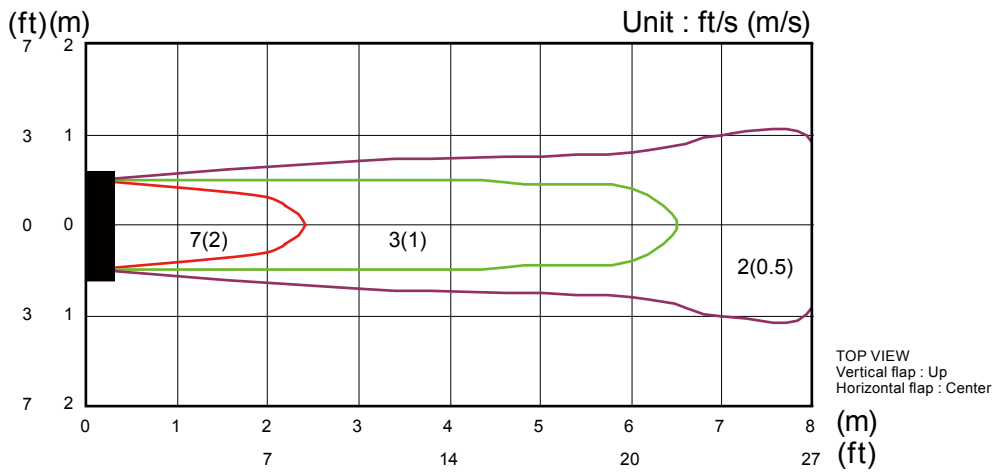

7-2. AIR FLOW

■ MODEL: ASU24CL1

● Cooling

Fan speed	Number of rotations (r.p.m.)	Air flow	
HIGH	1480	1120	m ³ /h
		311	l/s
		659	CFM
MED	1220	900	m ³ /h
		250	l/s
		530	CFM
LOW	1020	740	m ³ /h
		206	l/s
		436	CFM
QUIET	900	620	m ³ /h
		172	l/s
		365	CFM

8. OPERATION NOISE

8-1. NOISE LEVEL CURVE

■ MODEL: ASU24CL1

● Cooling

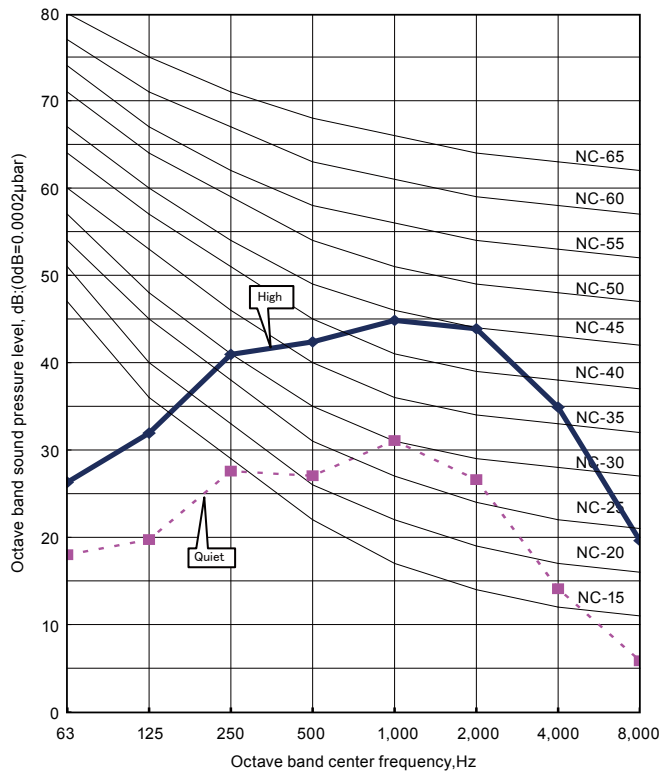

8-2. SOUND LEVEL CHECK POINT

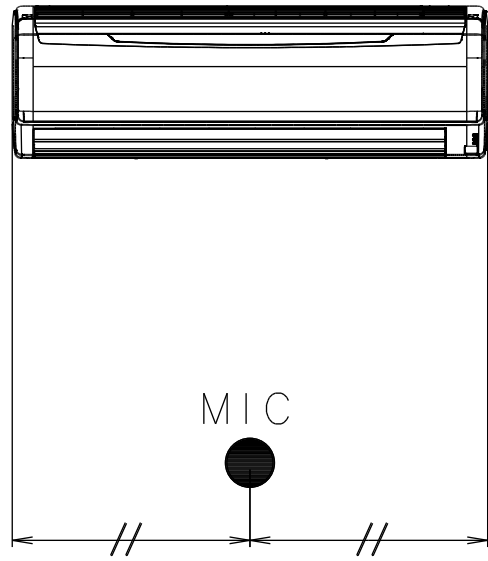
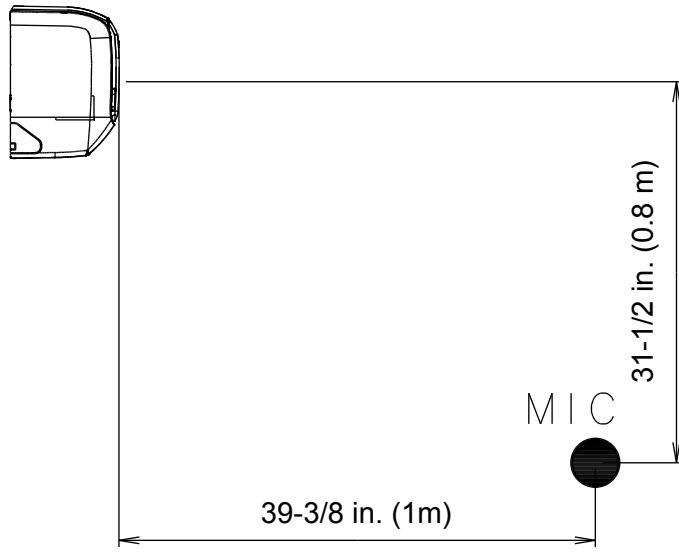

9. ELECTRIC CHARACTERISTICS

Model name		ASU24CL1	
Power supply	Voltage	V	208/230~
	Frequency	Hz	60
Max. operating current		A	0.3
*)Wiring Spec.	Connection cable	AWG	14
	Limited wiring length	ft.	102

*) Wiring Spec.

Selected Sample

(Selected based on Japan Electrotechnical Standard and Codes Committee E0005)

10. SAFETY DEVICES

	Protection form	Model
		ASU24CL1
Circuit protection	Current fuse (PCB)	3.15A 250V
Terminal protection	Current (thermal) fuse	3A 250V 215°F (102°C)
Fan motor protection	Thermal protector program	212 ⁺²⁷ ₋₁₈ °F (100 ⁺¹⁵ ₋₁₀ °C) OFF 203 ⁺⁹ ₋₁₈ °F (95 ⁺⁵ ₋₁₀ °C) ON

11. EXTERNAL INPUT & OUTPUT

Connector	INPUT	OUTPUT	REMARKS
CN14	Control input (Operation / stop)	-	See external input/output settings for details.
CN16	-	Operation status output	

11-1. EXTERNAL INPUT

■ CONTROL INPUT (Operation/Stop)

The air conditioner can be remotely operated by means of the following on-site work.

Operation is started at the following contents by adding the contact input of a commercial ON/OFF switch to a connector on the external control PC board and turning it ON.

	Initial starting after power turned on	Starting other than at the left
Operation mode	Auto changeover	Mode at previous operation
Set temperature	75°F (24°C)	Temperature at previous operation
Air flow mode	AUTO	Mode at previous operation
Up-down air direction (swing)	Standard air direction (swing OFF)	Air direction at previous operation
Left-right air direction (swing)	Standard air direction (swing OFF)	Air direction at previous operation

● Circuit diagram example

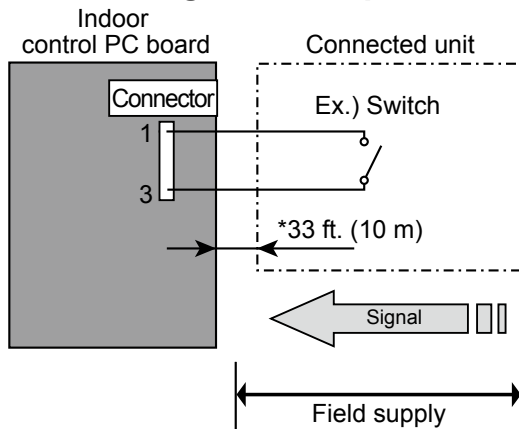

* Make the distance from the PC board to the connected unit within 33 ft. (10m).
Contact capacity : 5VDC or more, 20mA or more.
Please use the non-polar relays and switches.

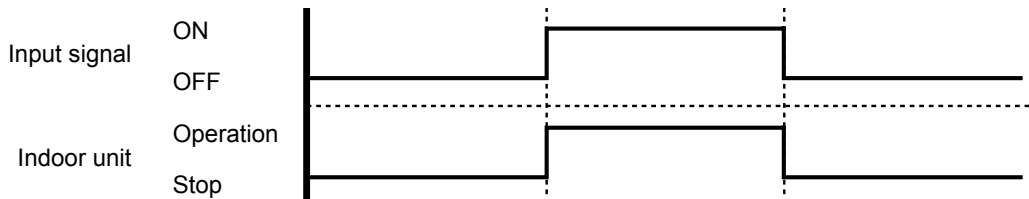

● Parts (Optional)

Parts name	Model name
External connect kit	UTY-XWZX

Wire (External input)

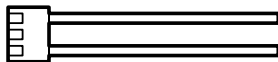

11-2. EXTERNAL OUTPUT

■ OPERATION STATUS OUTPUT

An air conditioner operation status signal can be output.

● Circuit diagram example

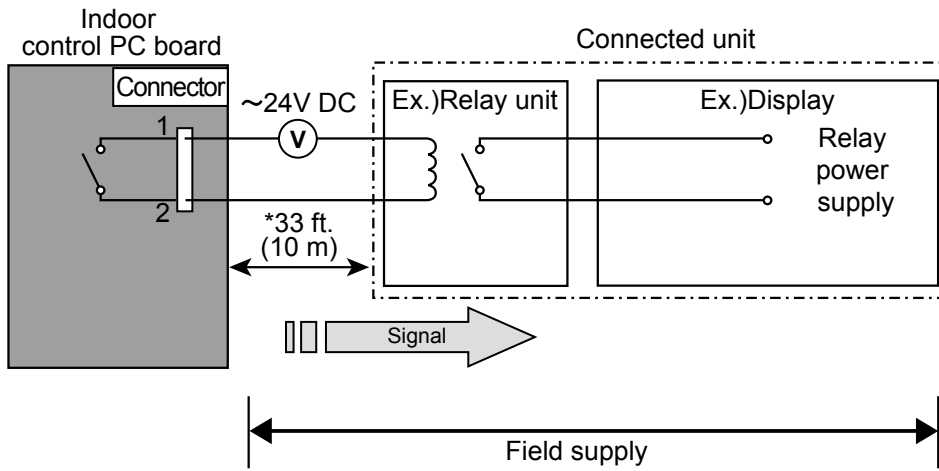

* Make the distance from the PC board to the connected unit within 33ft. (10m).
Relay spec. : Max.24VDC, 10mA to less than 500mA.

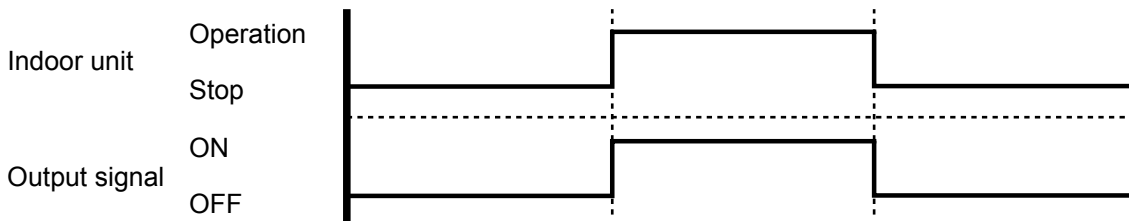

● Parts (Optional)

Parts name	Model name
External connect kit	UTY-XWZX

Wire (External output)

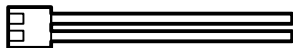

12. FUNCTION SETTING

12-1. INDOOR UNIT

INDOOR UNIT		
Jumper Wire	JM 5	Auto restart
	JM 6	Room temperature correction
	JM 7	
	JM 8	Remote controller signal code
	JM 10	

■ SWITCH POSITION

MAIN PCB

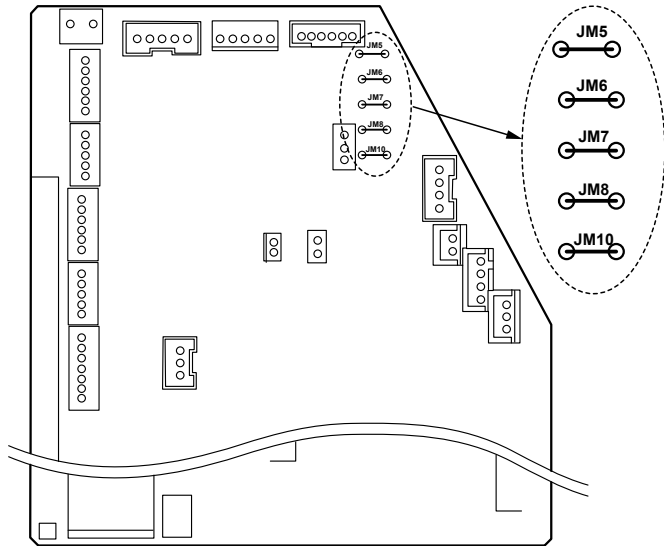

■ JUMPER WIRE SETTING

● Auto restart setting (JM5)

(◆... Factory setting)

JM 5	Auto restart
◆ Connect	Validity
Disconnect	Invalidity

● Room temperature correction setting (JM6, JM7)

(◆... Factory setting)

JM 6	JM 7	Room temperature correction	
		Cooling	Drying
◆ Connect	Connect	Standard	
Disconnect	Connect	Slightly lower control	
Connect	Disconnect	Slightly lower control	
Disconnect	Disconnect	Lower control	

● Remote controller signal code setting (JM8, JM10)

(◆... Factory setting)

Jumper wire		Remote controller signal code
JM 8	JM 10	
◆ Connect	Connect	A
Disconnect	Connect	B
Connect	Disconnect	C
Disconnect	Disconnect	D

■ REMOTE CONTROLLER SIGNAL CODE SETTING

Use the following steps to select the signal code of the remote controller.

(Note that the air conditioner cannot receive a signal code if the air conditioner has not been set for the signal code.)

1. Press the START/STOP button until only the clock is displayed on the remote controller display.
2. Press the MODE button for at least five seconds to display the current signal code (initially set to \overline{A}).
3. Press the SET TEMP. (\blacktriangle) (\blacktriangledown) button to change the signal code between $\overline{A} \rightarrow \overline{B} \rightarrow \overline{C} \rightarrow \overline{D}$.
Match the code on the display to the air conditioner signal code.
4. Press the MODE button again to return to the clock display. The signal code will be changed.

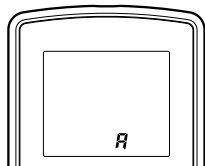



If no buttons are pressed within 30 seconds after the signal code is displayed, the system returns to the original clock display. In this case, start again from step 1.

The air conditioner signal code is set to A prior to shipment. Contact your retailer to change the signal code.

The remote controller resets to signal code A when the batteries in the remote controller are replaced. If you use a signal code other than signal code A, reset the signal code after replacing the batteries.
If you do not know the air conditioner signal code setting, try each of the signal codes ($\overline{A} \rightarrow \overline{B} \rightarrow \overline{C} \rightarrow \overline{D}$) until you find the code which operates the air conditioner.

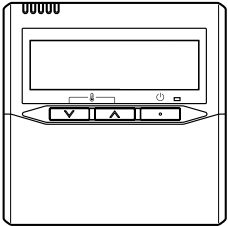
13. OPTIONAL PARTS

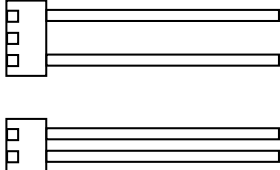
Exterior	Parts name	Model No.	Summary
	Wired remote controller	UTB-UUB	Unit control is performed by wired remote controller.
	Apple-catechin filter	UTR-FA13-1	Fine dust, invisible mold spores, and harmful microorganisms are absorbed onto the filter by static electricity, and further growth is inhibited and deactivated by the polyphenol ingredient extracted from apples.
	Ion deodorisation filter	UTR-FA13-2	The filter deodorizes by powerfully decomposing absorbed odors using the oxidizing and reducing effects of ions generated by the ultra fine-particle ceramic.
	External connect kit	UTY-XWZX	Use to connect with various peripheral devices and air conditioner PC board.

2. OUTDOOR UNIT

**SINGLE TYPE :
AOU24CL1**

CONTENTS

2. OUTDOOR UNIT

1. SPECIFICATIONS.....	02 - 01
2. DIMENSIONS	02 - 02
3. REFRIGERANT CIRCUIT	02 - 03
4. WIRING DIAGRAMS.....	02 - 04
5. CAPACITY COMPENSATION RATE FOR PIPE LENGTH AND HEIGHT DIFFERENCE	02 - 05
6. ADDITIONAL CHARGE CALCULATION.....	02 - 06
7. AIR FLOW.....	02 - 07
8. OPERATION NOISE.....	02 - 08
8-1. NOISE LEVEL CURVE	02 - 08
8-2. SOUND LEVEL CHECK POINT	02 - 09
9. ELECTRIC CHARACTERISTICS.....	02 - 10
10. SAFETY DEVICES	02 - 11

1. SPECIFICATIONS

OUTDOOR UNIT
AOU24CL1

OUTDOOR UNIT
AOU24CL1

Type				COOLING ONLY INVERTER	
Model name				AOU24CL1	
Power source				208/230V ~ 60Hz	
Available voltage range				187-253V ~ 60Hz	
Starting current			A	10.5	
Fan	Airflow rate	Cooling	CFM (m ³ /h)	1,554 (2,640)	
	Type × Q'ty			Propeller fan×1	
	Motor output			W	40
Sound pressure level		Cooling	dB(A)	56	
Heat exchanger type	Dimensions (H × W × D)		inch	23-1/8 × 34-11/16 × 1-7/16	
			mm	588 × 881 × 36.4	
	Fin pitch		mm	1.3	
	Rows × Stages			2 × 28	
	Pipe type			Copper	
	Fin	Type(Material)		Corrugate (Aluminum)	
Surface treatment		Corrosion resistance (Blue fin)			
Compressor	Type × Q'ty			Rotary × 1	
	Motor output			W	1,100
Refrigerant	Type			R410A	
	Charge		lb.oz.	2 lb. 13.9 oz.	
			kg	1.3	
Refrigerant oil		Type			POE (VG74)
Enclosure	Material			Steel	
	Color			BEIGE Approximate color of MUNSELL 10YR7.5/1.0	
Dimensions (H × W × D)	Net			mm	620 × 790 × 298
				inch	24-7/16 × 31-1/8 × 11-3/4
	Gross			mm	712 × 935 × 400
				inch	28-1/16 × 36-13/16 × 15-3/4
Weight	Net		lb.(kg)	88 (40)	
	Gross			97 (44)	
Connection pipe	Size	Liquid	inch	Ø1/4 (Ø6.35)	
		Gas	(mm)	Ø5/8 (Ø15.88)	
	Method			Flare	
	Max. length			ft.	98 (30) [chargeless: 49 (15)]
	Max. height difference			(m)	66 (20)
Operation range		Cooling	°F (°C)	14 to 115 (-10 to 46)	

Note :

Specifications are based on the following conditions.

Cooling : Indoor temperature of 80°F (26.7 °C)DB / 67°F (19.4 °C)WB and outdoor temperature of 95°F (35 °C)DB / 75°F(23.9 °C)WB.

Pipe length : 25ft. (7.5 m), Height difference : 0 m.(Outdoor unit - Indoor unit)

2. DIMENSIONS

MODEL: AOU24CL1

Unit : in. (mm)

OUTDOOR UNIT
AOU24CL1

OUTDOOR UNIT
AOU24CL1

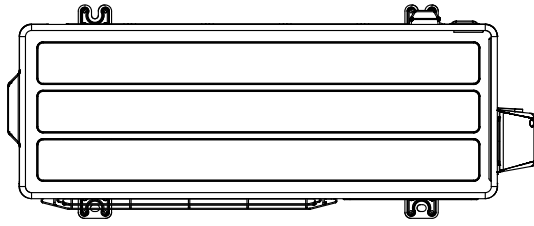

Top view

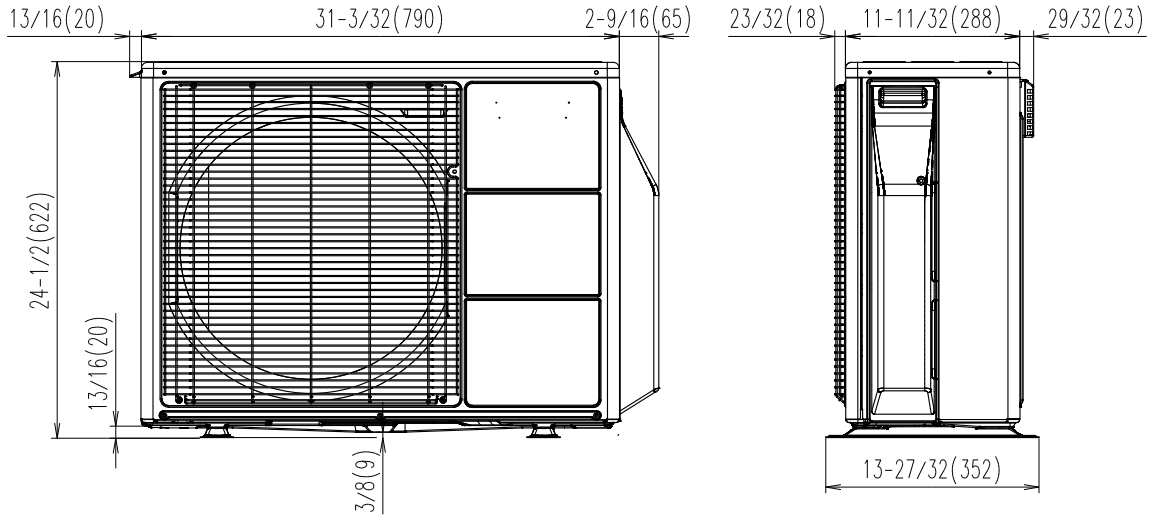

Front view

Side view

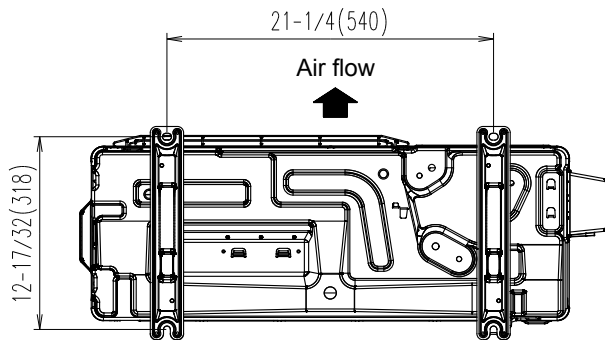

Bottom view

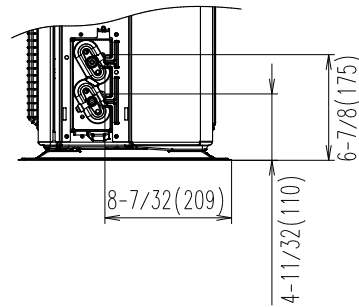

INSTALLATION PLACE

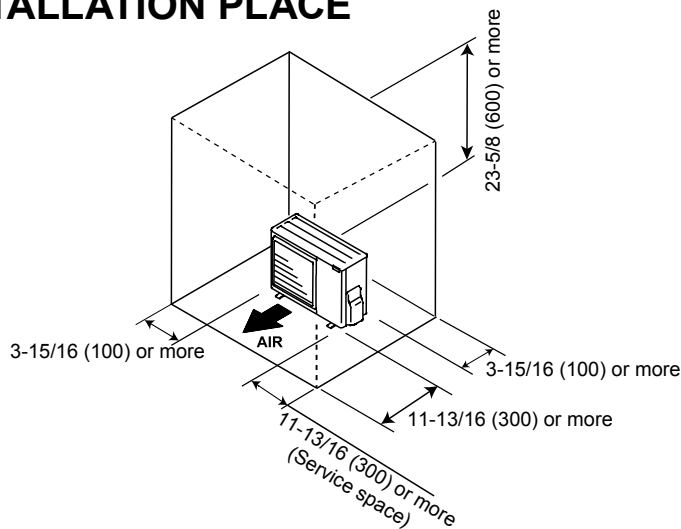

If the space is larger that is stated, the condition will be the same as that are no obstacles.

3. REFRIGERANT CIRCUIT

■ MODEL: AOU24CL1

OUTDOOR UNIT
AOU24CL1

OUTDOOR UNIT
AOU24CL1

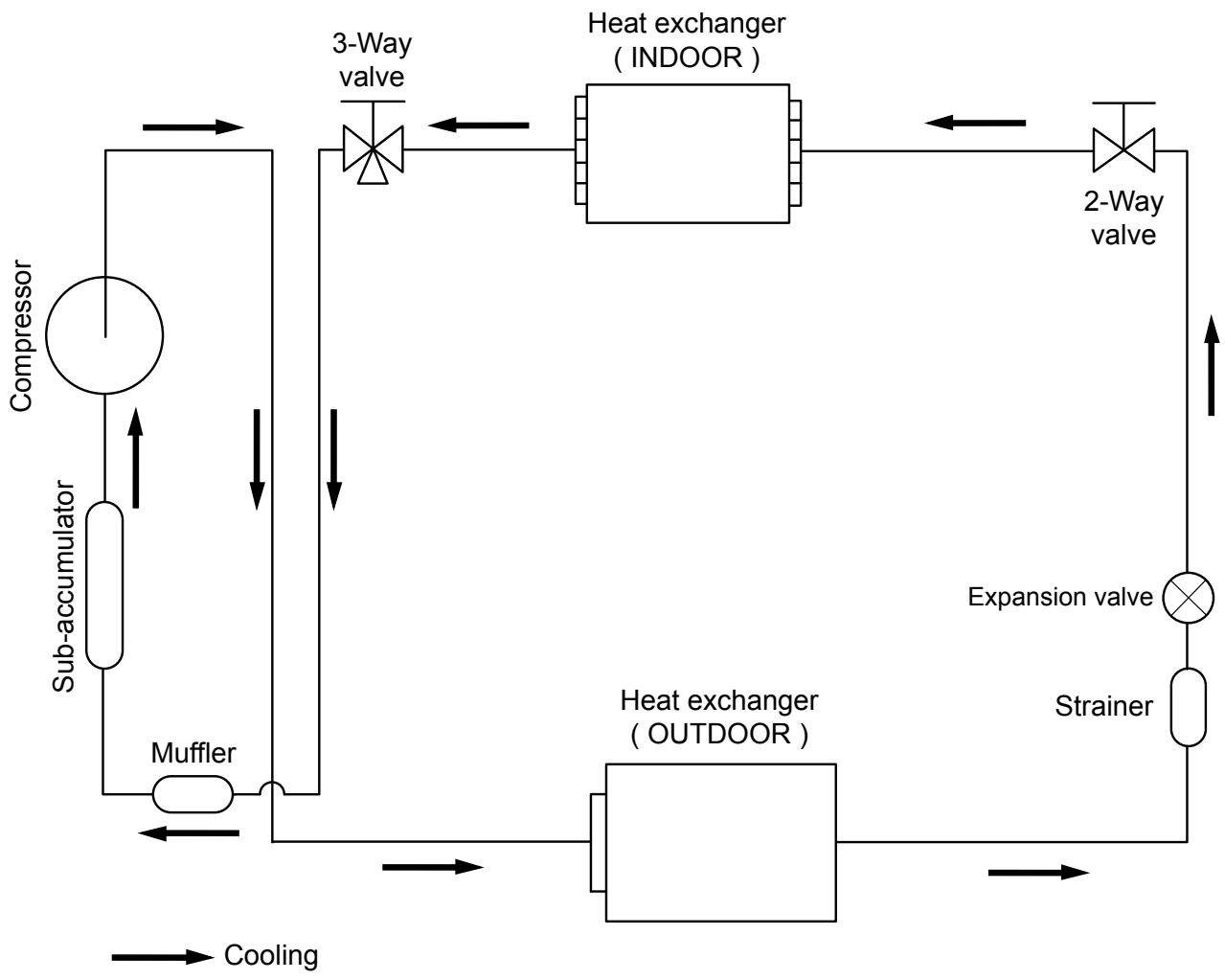

Refrigerant pipe diameter
Liquid : 1/4" (6.35 mm)
Gas : 5/8" (15.88 mm)

5. CAPACITY COMPENSATION RATE FOR PIPE LENGTH AND HEIGHT DIFFERENCE

MODEL: AOU24CL1

OUTDOOR UNIT
AOU24CL1

OUTDOOR UNIT
AOU24CL1

COOLING				Pipe length (m)						
				5	7.5	10	15	20	25	30
				16ft.	25ft.	33ft.	49ft.	66ft.	82ft.	98ft.
Height difference H (m)	*1 Indoor unit is upper than outdoor unit.	20	66ft.	-	-	-	-	0.951	0.951	0.950
		10	33ft.	-	-	0.980	0.966	0.967	0.967	0.966
		7.5	25ft.	-	0.988	0.984	0.970	0.971	0.971	0.970
		5	16ft.	0.995	0.992	0.988	0.974	0.975	0.975	0.974
		0	0ft.	1.003	1.000	0.996	0.982	0.983	0.983	0.982
	*2 Indoor unit is under than outdoor unit	-5	-16ft.	1.003	1.000	0.996	0.982	0.983	0.983	0.982
		-7.5	-25ft.	-	1.000	0.996	0.982	0.983	0.983	0.982
		-10	-33ft.	-	-	0.996	0.982	0.983	0.983	0.982
		-20	-66ft.	-	-	-	-	0.983	0.983	0.982

Height difference H

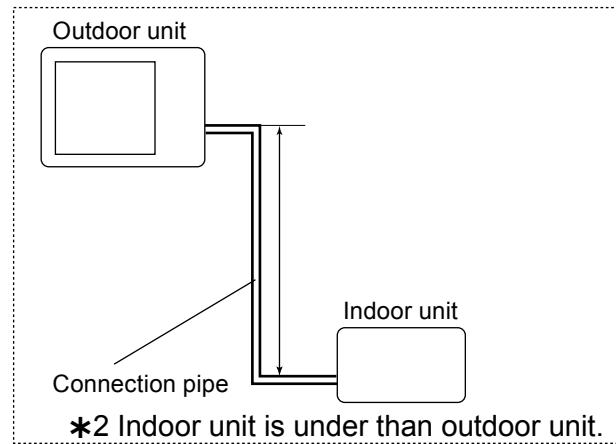
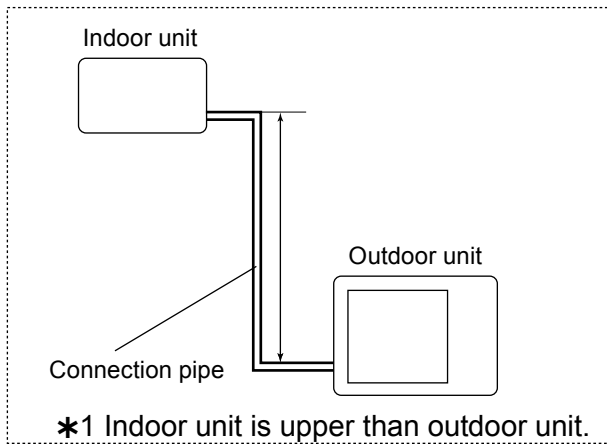

6. ADDITIONAL CHARGE CALCULATION

■ MODEL: AOU24CL1

Refrigerant type		R410A
Refrigerant amount	lb.oz.	2lb. 13.9oz.
	g	1300

● Refrigerant charge

Pipe length	ft.	~ 49	66	82	98	0.22oz./ft. (20g/m)
	m	~ 15	20	25	30	
Additional charge	oz.	0 (Charge less)	3.5	7.1	10.6	
	g	0 (Charge less)	+100	+200	+300	

7. AIR FLOW

■ MODEL: AOU24CL1

● Cooling

Number of rotations (r.p.m.)	Air flow	
	1100	2640
733		l/s
1554		CFM

8. OPERATION NOISE

8-1. NOISE LEVEL CURVE

■ MODEL: AOU24CL1

● Cooling

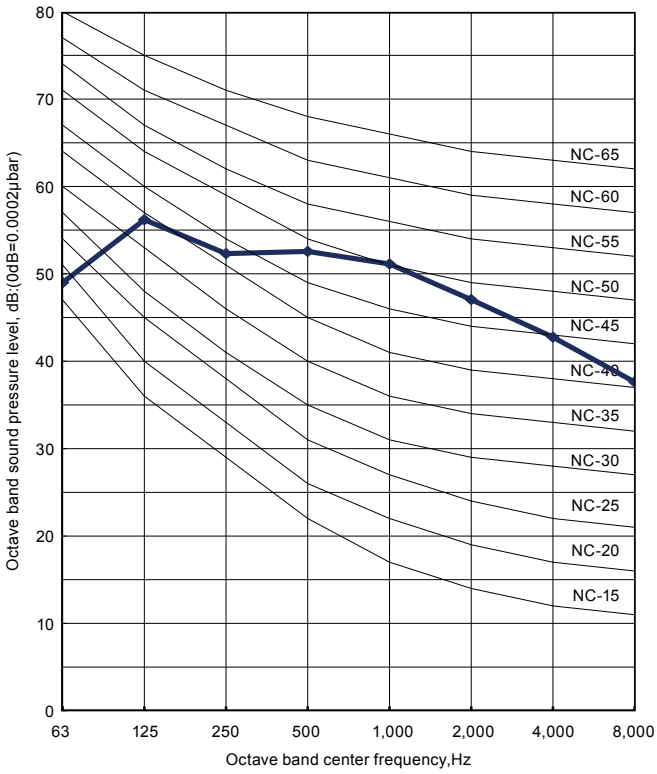

OUTDOOR UNIT
AOU24CL1

OUTDOOR UNIT
AOU24CL1

8-2. SOUND LEVEL CHECK POINT

OUTDOOR UNIT
AOU24CL1

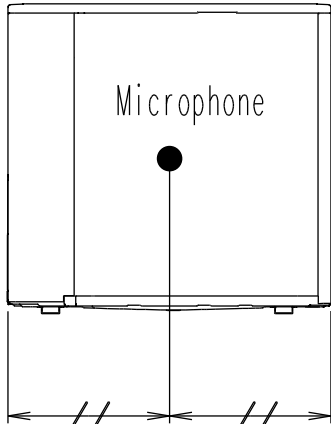
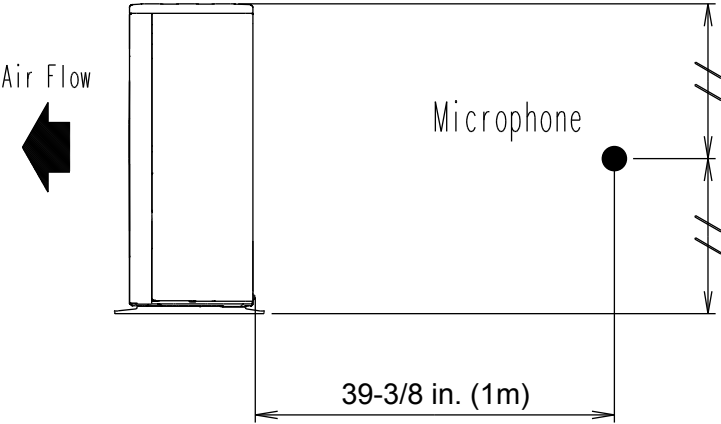

OUTDOOR UNIT
AOU24CL1

9. ELECTRIC CHARACTERISTICS

Model name			AOU24CL1
Power supply	Voltage	V	208/230 ~
	Frequency	Hz	60
*1) Max operating current		A	11.5
Starting Current		A	10.5
*2) Wiring spec.	Main Fuse (Circuit breaker) Current	A	20
	Power Cable	AWG	11
	*3) Limited wiring length	ft.	66

*1) The maximum current is the total current of indoor unit and outdoor unit.

*2)Wiring spec.

Selected Sample

(Selected based on Japan Electrotechnical Standard and Codes Committee E0005)

*3) Limited wiring length

This is the wiring length in case voltage descent is less than 2%.

When the wiring length becomes long, please select the wiring of a more larger diameter.

10. SAFETY DEVICES

	Protection form	Model
		AOU24CL1
Circuit protection	Current fuse (NEAR THE TERMINAL)	20A 250V
		5A 250V
	Current fuse (MAIN PRINTED CIRCUIT BOARD)	15A 250V
		3.15A 250V
Fan motor protection	Thermal protection program	OFF : 212±50°F (100±10°C) ON : 203±50°F (95±10°C)
Compressor protection	Thermal protection program (DISCHARGE TEMP.)	OFF : 230°F (110°C) ON : After 7 minutes

OUTDOOR UNIT
AOU24CL1

OUTDOOR UNIT
AOU24CL1