

CONDENSING UNITS



RAPL- JEZ **R-410A**

14 SEER Models
Efficiencies up to 16.00 SEER
Nominal Sizes 1 1/2 to 5 Tons
[5.28 kW] to [17.6 kW]

Seven Models
Cooling Capacities
18,200 to 59,500 BTU/HR
[5.33 kW] to [17.44 kW]

Equipped with **Comfort Control System™**

- Increased Reliability
- On-Board Diagnostics
- Fault Recall
- *Active Protection™*



The Rheem *Prestige Series™* High Efficiency RAPL- JEZ Condensing Units were designed with performance in mind. These units offer comfort, energy conservation and dependability for single, multi-family and light commercial applications.

These units also contain the most advanced alternate refrigerant which contains no chlorofluorocarbons (CFCs), or hydrochlorofluorocarbons (HCFCs), or other compounds that may leak from air-conditioning systems and potentially harm the protective ozone layer of the Earth's atmosphere.

The Rheem *Prestige Series™* RAPL- JEZ Condensing Units are the result of an ongoing development program for improved efficiencies. These units are flexible enough to achieve up to 16.00 SEER in specific match-ups, continuing a tradition of high efficiency.

- The *Comfort Control System™* provides on-board diagnostics and fault history for condensing units with single-phase compressors by detecting system and electrical problems without adding sensors. It can also communicate "fault codes" to enabled "L terminal" thermostats. The integrated diagnostics with *Active Protection™* prevents compressor operation when potentially harmful conditions are detected.
- 7-Segment LED Display is exclusive only to Rheem products. The information-display quickly and accurately shows technicians the source of malfunctions.
- Features a five-year conditional unit replacement warranty when properly installed with a new Rheem *Prestige Series™* Air Handler or Rheem Indoor Coil with a *Prestige Series™* Gas Furnace. See product warranty card for additional information.
- Compressor sound blanket is standard to provide quiet operation.
- Attractive, louvered wrap-around jacket protects the coil from yard hazards and weather extremes. Top grille is steel reinforced for extra strength. Cabinet is powder painted for all-weather protection.
- Air is discharged upward away from bushes and shrubs. The discharge pattern of the top grille provides minimum air restriction.
- Combination Grille/Motor Mount secures the motor to the underside of the discharge grille. The grille protects the motor windings and bearings from rain and snow.
- Removable top grille provides access to the condenser fan motor and condenser coil.
- Single speed 8-pole fan motor designed for low speed, quiet, energy-saving operation.
- All models meet or exceed a 1000-hour salt spray test per ASTM B117 Standard Practice for Operating Salt Spray Testing Apparatus.

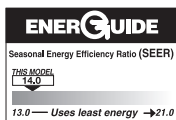

14 SEER MODELS
(IN CERTAIN MATCHED SYSTEMS)



FEATURES & BENEFITS OF THE *COMFORT CONTROL SYSTEM*™

- The Rheem exclusive 7-Segment LED Display easily shows system operating status codes and diagnostic codes.

- A Sealed Switch replaces the standard contactor and features optical control and latching mechanism.



The sealed switch prevents infiltration of insects and dust. A minimal switching arc, by the optical control, offers greater reliability. The latching mechanism consumes less power while reducing chatter.



- The Status Indication and System Diagnostics feature thermostat communication capability, built-in diagnostics, high & low voltage monitoring and high & low pressure switch monitoring. The thermostat communication capability alerts the homeowner to any necessary service requirements. Faster, more accurate service is provided by the built-in diagnostics, by providing the HVAC professional with dependable information. With the high and low voltage monitoring feature, the control provides alerts for out-of-range conditions. In addition, high and low pressure-switch monitoring prevents the system from operating outside of its normal parameters.



- The fault recall feature will allow for the last six fault-codes to be displayed, and will retain these codes even if power failure occurs.
- Built-in short-cycle protection allows the compressor to restart easily without oil removal.
- A 30-second minimum run-time for every compressor call enables the oil return to the compressor.
- *Active Protection* monitors the system to prevent nuisance lockouts and prevents compressor operation when potentially harmful conditions are detected.
- The compressor and fan are controlled independently, which reduces the starting load and light dimming.
- A push-button is offered to operate the compressor and fan for 5 seconds to allow for an operation check.
- In order to save time and money, replacement automotive fuses can be utilized instead of replacing the entire control board.

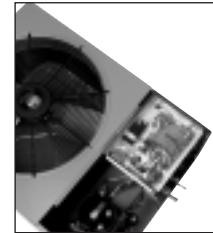

STANDARD FEATURES

RAPL- JEZ Condensing Units

1. This unit contains a special scroll compressor that is designed specifically to operate with R-410A refrigerants and polyolester (POE) oils. The compressor is hermetically sealed and incorporates internal high temperature motor overload protection and durable insulation on the motor windings. It is externally mounted on rubber grommets to reduce vibration and noise.
2. Scroll compressor is hermetically sealed and incorporates internal high temperature motor overload protection, and durable insulation on the motor windings. It is externally mounted on rubber grommets to reduce vibration and noise.
3. Compressors have an internal pressure relief assembly to protect against excessive pressure differential.
4. All refrigerant connections are on the exterior of the unit, located close to the ground for neat appearing installations.
5. Cabinet is constructed of powder painted galvanized steel. The full wrap-around louvered grille protects the coil from damage.
6. Enhanced compressor sound blanket is standard.
7. Copper tube—aluminum fin coils are used on all models.
8. The control box is located in the top corner of the cabinet providing for easy access through a service panel.
9. Service valves are standard on all models.
10. Field connections for power and control wiring are kept separate.
11. Every unit is factory charged and run-tested.
12. Separate compressor compartment for easy service access.
13. Drawn, painted base pan for extra corrosion resistance and sound reduction.
14. The **RAPL- JEZ** has a 10 year limited compressor warranty, plus a 5 year conditional unit replacement warranty. See General Terms of Limited Warranty for more details.
15. **Hard Start Kits**—Standard on all JEZ models.
16. Control Box Cover.
17. Automatic reset high and low pressure controls are standard on all JEZ models.
18. Liquid line filter drier is standard on all models (shipped – not installed).

Problem-Solving Accuracy

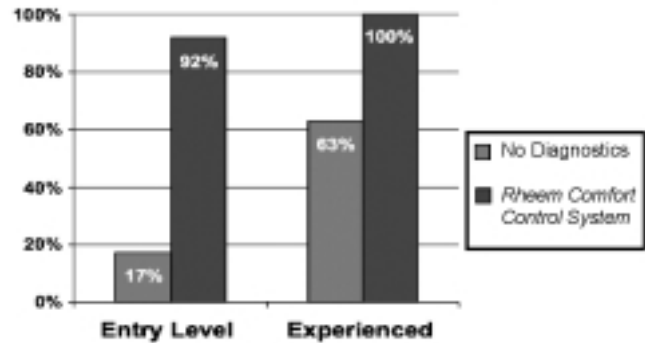

SCROLL® COMPRESSOR

The scroll compressor is the key to efficiency for this Rheem model. It's the latest in high-efficiency compressor technology. The advanced scroll compressor offers low noise and vibration characteristics and features tolerance to liquid refrigerant and system contamination. The scroll compressor also has low start torque, eliminating start problems in the field. And its unique design enables the RAPL- JEZ condensing units to perform efficiently, quietly and dependably.



All controls and compressor are accessible for servicing by removal of the service panel.

Model Number Identification

<u>R</u>	<u>A</u>	<u>P</u>	<u>L</u>	<u>—</u>	<u>018</u>	<u>J</u>	<u>E</u>	<u>Z</u>
RHEEM	REMOTE CONDENSING UNIT	P = 14 SEER	DESIGN SERIES L = R-410A		COOLING CAPACITY 018 = 18,000 BTU/HR [5.28 kW] (RAPL MODELS ONLY) 024 = 24,000 BTU/HR [7.03 kW] 030 = 30,000 BTU/HR [8.79 kW] 036 = 36,000 BTU/HR [10.55 kW] 042 = 42,000 BTU/HR [12.31 kW] 048 = 48,000 BTU/HR [14.07 kW] 060 = 60,000 BTU/HR [17.58 kW]	J = 208/230V-1-60	VARIATIONS EQUIPPED WITH THE COMFORT CONTROL SYSTEM™	COOLING CONNECTION FITTING Z = SWEAT W/SCROLL

Field Installed Accessories

- Low Ambient Control**—Cycles outdoor fan to maintain adequate condensing pressures assuring liquid refrigerant flow to the coil. Allows indoor cooling with outdoor temperatures down to 0°F [-17.8°C]. (Model No. RXAD-A08)
 It is recommended that this control be installed in units to be operated at outdoor ambient temperatures under 70°F [21°C].
- Compressor Crankcase Heater (CCH)**—While scroll compressors usually do not require crankcase heaters, there are instances when a heater should be added. Refrigerant migration during the off cycle can result in a noisy start up. Add a crankcase heater to minimize refrigeration migration, and to help eliminate any start up noise or bearing “wash out.”

Thermostats—



300-Series *
Deluxe Programmable



200-Series *
Programmable



100-Series *
Non-Programmable

400-Series *
Special Applications/Programmable

Brand	Unique Model Number Prefix	Descriptor (3 Characters)	Series (3 Characters)	System (2 Characters)	Type (2 Characters)
RHC	-	TST	101	GE	MS
RHC=Rheem		TST=Thermostat	100=Non-Programmable	GE=Gas/Oil/Electric	SS=Single-Stage
			200=Programmable	HP=Heat Pump	MS=Multi-Stage
			300=Deluxe Programmable	MD=Modulating Furnace	
			400=Special Applications/Programmable	DF=Dual Fuel	
				UN=Universal AC/HP/GE	

* Photos are representative. Actual models may vary.

For detailed thermostat match-up information, see specification sheet form number T11-001.

[] Designates Metric Conversions

Performance Data @ ARI Standard Conditions—Cooling: RAPL- JEZ

Outdoor Unit RAPL-	Model Numbers	80°F [26.5°C] DB/67°F [19.5°C] WB Indoor Air 95°F [35°C] DB Outdoor Air					Sound Rating dB	Indoor CFM [L/s]
		Total Capacity BTU/H [kW]	Net Sensible BTU/H [kW]	Net Latent BTU/H [kW]	EER	SEER		
018JEZ	RCFL-H*2417A*+RXMD-C04 ①	19,100 [5.6]	13,700 [4.0]	5,400 [1.6]	12.00	14.00	74	600 [283]
	RCFL-A*2414B*+RXMD-C04	19,100 [5.6]	13,700 [4.0]	5,400 [1.6]	12.00	14.00	74	600 [283]
	RCFL-A*2417B* (RGFD-06?MCK?)	19,500 [5.7]	14,000 [4.1]	5,500 [1.6]	13.15	15.50	74	600 [283]
	RCFL-A*2417B* (RGFD-07?MCK?)	19,500 [5.7]	14,000 [4.1]	5,500 [1.6]	13.20	15.50	74	600 [283]
	RCFL-A*2417B* (RGGD-06?MCK?)	19,600 [5.7]	14,050 [4.1]	5,550 [1.6]	13.35	15.50	74	600 [283]
	RCFL-A*2417B* (RGGD-07?MCK?)	19,600 [5.7]	14,050 [4.1]	5,550 [1.6]	13.25	15.50	74	625 [295]
	RCFL-A*2417B* (RGLR-07?AMK?)	19,600 [5.7]	14,050 [4.1]	5,550 [1.6]	13.40	15.50	74	600 [283]
	RCFL-A*2417B* (RGPR-05?BMK?)	19,500 [5.7]	14,000 [4.1]	5,500 [1.6]	13.10	15.00	74	600 [283]
	RCFL-A*2417B* (RGPR-07?AMK?)	19,600 [5.7]	14,050 [4.1]	5,550 [1.6]	13.30	15.50	74	600 [283]
	RCFL-A*2417B*+RXMD-C04	19,100 [5.6]	13,700 [4.0]	5,400 [1.6]	12.00	14.00	74	600 [283]
	RCFL-H*2414A*+RXMD-C04	19,100 [5.6]	13,700 [4.0]	5,400 [1.6]	12.00	14.00	74	600 [283]
	RCFL-H*2417A* (RGFD-06?MCK?)	19,500 [5.7]	14,000 [4.1]	5,500 [1.6]	13.15	15.50	74	600 [283]
	RCFL-H*2417A* (RGFD-07?MCK?)	19,500 [5.7]	14,000 [4.1]	5,500 [1.6]	13.20	15.50	74	600 [283]
	RCFL-H*2417A* (RGGD-06?MCK?)	19,600 [5.7]	14,050 [4.1]	5,550 [1.6]	13.35	15.50	74	600 [283]
	RCFL-H*2417A* (RGGD-07?MCK?)	19,600 [5.7]	14,050 [4.1]	5,550 [1.6]	13.25	15.50	74	625 [295]
	RCFL-H*2417A* (RGJD-06?MCK?)	19,600 [5.7]	14,050 [4.1]	5,550 [1.6]	13.35	15.50	74	600 [283]
	RCFL-H*2417A* (RGJD-07?MCK?)	19,600 [5.7]	14,050 [4.1]	5,550 [1.6]	13.25	15.50	74	625 [295]
	RCFL-H*2417A* (RGLR-07?AMK?)	19,600 [5.7]	14,050 [4.1]	5,550 [1.6]	13.40	15.50	74	600 [283]
	RCFL-H*2417A* (RGPR-05?BMK?)	19,500 [5.7]	14,000 [4.1]	5,500 [1.6]	13.10	15.00	74	600 [283]
	RCFL-H*2417A* (RGPR-07?AMK?)	19,600 [5.7]	14,050 [4.1]	5,550 [1.6]	13.30	15.50	74	600 [283]
	17AHBL24HM (RCHL-24A2)	18,700 [5.5]	12,700 [3.7]	6,000 [1.8]	12.75	14.50	74	650 [307]
	RBHK-17 (RCHL-24A2)	18,300 [5.4]	12,700 [3.7]	5,600 [1.6]	12.65	15.00	74	600 [283]
	RBHP-17 (RCHL-24A2)	18,700 [5.5]	12,700 [3.7]	6,000 [1.8]	12.75	14.50	74	650 [307]
	RCHL-24A2 (RGFD-06?MCK?)	18,200 [5.3]	12,650 [3.7]	5,550 [1.6]	12.40	14.50	74	600 [283]
	RCHL-24A2 (RGFD-07?MCK?)	18,200 [5.3]	12,650 [3.7]	5,550 [1.6]	12.40	14.50	74	600 [283]
	RCHL-24A2 (RGGD-06?MCK?)	18,200 [5.3]	12,700 [3.7]	5,500 [1.6]	12.55	14.50	74	600 [283]
	RCHL-24A2 (RGGD-07?MCK?)	18,200 [5.3]	12,650 [3.7]	5,550 [1.6]	12.50	14.50	74	625 [295]
	RCHL-24A2 (RGJD-06?MCK?)	18,200 [5.3]	12,700 [3.7]	5,500 [1.6]	12.55	14.50	74	600 [283]
	RCHL-24A2 (RGJD-07?MCK?)	18,200 [5.3]	12,650 [3.7]	5,550 [1.6]	12.50	14.50	74	625 [295]
	RCHL-24A2 (RGLR-07?AMK?)	18,200 [5.3]	12,700 [3.7]	5,500 [1.6]	12.60	14.50	74	600 [283]
	RCHL-24A2 (RGPR-05?BMK?)	18,200 [5.3]	12,600 [3.7]	5,600 [1.6]	12.30	14.50	74	600 [283]
	RCHL-24A2 (RGPR-07?AMK?)	18,200 [5.3]	12,650 [3.7]	5,550 [1.6]	12.55	14.50	74	600 [283]
	RCHL-24A2+RXMD-C04	17,700 [5.2]	12,150 [3.6]	5,550 [1.6]	11.05	13.00	74	600 [283]
	RCQD-2417A*	19,300 [5.7]	14,150 [4.1]	5,150 [1.5]	11.90	14.00	74	600 [283]
	RCQD-2417A* (RGFD-06?MCK?)	19,600 [5.7]	14,350 [4.2]	5,250 [1.5]	13.20	15.50	74	600 [283]
	RCQD-2417A* (RGFD-07?MCK?)	19,600 [5.7]	14,350 [4.2]	5,250 [1.5]	13.25	15.50	74	600 [283]
	RCQD-2417A* (RGPL-05?BMK?)	19,600 [5.7]	14,350 [4.2]	5,250 [1.5]	13.15	15.50	74	600 [283]
	RCQD-2417A* (RGPL-07?BRK?)	19,700 [5.8]	14,450 [4.2]	5,250 [1.5]	13.35	16.00	74	600 [283]
	RCQD-2417A* (RGPR-05?BMK?)	19,600 [5.7]	14,350 [4.2]	5,250 [1.5]	13.15	15.50	74	600 [283]
	RCQD-2417A* (RGPR-07?AMK?)	19,700 [5.8]	14,450 [4.2]	5,250 [1.5]	13.35	16.00	74	600 [283]
17AHSL18AU (RCSL-A*2417A*)	19,300 [5.7]	13,850 [4.1]	5,450 [1.6]	12.35	14.00	74	600 [283]	
17AHLL24HM (RCSL-H*2417A*)	19,600 [5.7]	14,050 [4.1]	5,550 [1.6]	13.20	15.50	74	600 [283]	
17AHSL18HM (RCSL-H*2417A*)	19,300 [5.7]	13,850 [4.1]	5,450 [1.6]	12.35	14.00	74	600 [283]	
RHKL-HM2417 (RCSL-H*2417A*)	19,900 [5.8]	14,250 [4.2]	5,650 [1.7]	13.45	15.50	74	650 [307]	
RHLL-HM2417 (RCSL-H*2417A*)	19,600 [5.7]	14,050 [4.1]	5,550 [1.6]	13.20	15.50	74	600 [283]	
RHSL-HM1817 (RCSL-H*2417A*)	19,300 [5.7]	13,850 [4.1]	5,450 [1.6]	12.35	14.00	74	600 [283]	
024JEZ	RCFL-H*2417A* ①	24,000 [7.0]	17,400 [5.1]	6,600 [1.9]	12.05	14.00	72	800 [378]
	RCFL-A*2414B*	24,000 [7.0]	17,400 [5.1]	6,600 [1.9]	12.05	14.00	72	800 [378]
	RCFL-A*2417B*	24,000 [7.0]	17,400 [5.1]	6,600 [1.9]	12.05	14.00	72	800 [378]
	RCFL-A*2417B* (RGFD-06?MCK?)	24,400 [7.1]	17,650 [5.2]	6,750 [2.0]	12.85	15.00	72	800 [378]
	RCFL-A*2417B* (RGFD-07?MCK?)	24,400 [7.1]	17,700 [5.2]	6,700 [2.0]	12.95	15.00	72	800 [378]
	RCFL-A*2417B* (RGGD-06?MCK?)	24,400 [7.1]	17,750 [5.2]	6,650 [1.9]	13.15	15.50	72	800 [378]
	RCFL-A*2417B* (RGGD-07?MCK?)	24,400 [7.1]	17,750 [5.2]	6,650 [1.9]	13.05	15.00	72	800 [378]
	RCFL-A*2417B* (RGLR-07?AMK?)	24,600 [7.2]	17,800 [5.2]	6,800 [2.0]	13.35	15.50	72	800 [378]
	RCFL-A*2417B* (RGPR-05?BMK?)	24,400 [7.1]	17,700 [5.2]	6,700 [2.0]	12.95	15.00	72	775 [366]
	RCFL-A*2417B* (RGPR-07?AMK?)	24,600 [7.2]	17,800 [5.2]	6,800 [2.0]	13.25	15.50	72	800 [378]

① Highest sales volume tested combination required by D.O.E. test procedures.

[] Designates Metric Conversions

Performance Data @ ARI Standard Conditions—Cooling: RAPL- JEZ (continued)

Outdoor Unit RAPL-	Model Numbers	80°F [26.5°C] DB/67°F [19.5°C] WB Indoor Air 95°F [35°C] DB Outdoor Air					Sound Rating dB	Indoor CFM [L/s]
		Total Capacity BTU/H [kW]	Net Sensible BTU/H [kW]	Net Latent BTU/H [kW]	EER	SEER		
030JEZ	RCFL-H*3621A* (RGFD-07?MCK?)	29,000 [8.5]	21,450 [6.3]	7,550 [2.2]	12.45	14.50	73	1,000 [472]
	RCFL-H*3621A* (RGGD-06?MCK?)	29,000 [8.5]	21,500 [6.3]	7,500 [2.2]	12.50	14.50	73	1,000 [472]
	RCFL-H*3621A* (RGJD-06?MCK?)	29,000 [8.5]	21,500 [6.3]	7,500 [2.2]	12.50	14.50	73	1,000 [472]
	RCFL-H*3621A* (RGPR-05?BMK?)	29,000 [8.5]	21,450 [6.3]	7,550 [2.2]	12.35	14.50	73	1,000 [472]
	RCFL-H*3621A* (RGPR-07?AMK?)	29,000 [8.5]	21,550 [6.3]	7,450 [2.2]	12.70	14.50	73	1,000 [472]
	RCFL-H*3621A* (RGPR-07?BRQ?)	29,400 [8.6]	21,700 [6.4]	7,700 [2.3]	13.15	15.50	73	1,000 [472]
	RCFL-H*3621A*+RXMD-C04	28,400 [8.3]	21,050 [6.2]	7,350 [2.2]	12.00	14.00	73	950 [448]
	RCHL-36A1	27,000 [7.9]	19,200 [5.6]	7,800 [2.3]	11.25	13.00	73	950 [448]
	21AHBL36HM (RCHL-36A1)	28,200 [8.3]	20,550 [6.0]	7,650 [2.2]	12.85	15.00	73	1,050 [495]
	RBHK-21 (RCHL-36A1)	28,000 [8.2]	20,000 [5.9]	8,000 [2.3]	12.85	15.00	73	1,000 [472]
	RBHP-21 (RCHL-36A1)	28,200 [8.3]	20,550 [6.0]	7,650 [2.2]	12.85	15.00	73	1,050 [495]
	RCHL-36A1 (RGFD-07?MCK?)	27,600 [8.1]	19,600 [5.7]	8,000 [2.3]	12.10	14.00	73	1,000 [472]
	RCHL-36A1 (RGGD-06?MCK?)	27,800 [8.1]	19,700 [5.8]	8,100 [2.4]	12.25	14.00	73	1,000 [472]
	RCHL-36A1 (RGJD-06?MCK?)	27,800 [8.1]	19,700 [5.8]	8,100 [2.4]	12.25	14.00	73	1,000 [472]
	RCHL-36A1 (RGPR-05?BMK?)	27,600 [8.1]	19,600 [5.7]	8,000 [2.3]	12.05	14.00	73	1,000 [472]
	RCHL-36A1 (RGPR-07?AMK?)	27,800 [8.1]	19,750 [5.8]	8,050 [2.4]	12.40	14.50	73	1,000 [472]
	RCHL-36A1 (RGPR-07?BRQ?)	28,000 [8.2]	19,950 [5.8]	8,050 [2.4]	12.80	15.00	73	1,000 [472]
	RCQD-3621A*	29,200 [8.6]	22,200 [6.5]	7,000 [2.1]	12.20	14.00	73	1,000 [472]
	RCQD-3621A* (RGFD-06?MCK?)	29,600 [8.7]	22,550 [6.6]	7,050 [2.1]	12.75	14.50	73	1,000 [472]
	RCQD-3621A* (RGFD-07?MCK?)	29,600 [8.7]	22,500 [6.6]	7,100 [2.1]	13.00	15.00	73	1,000 [472]
	RCQD-3621A* (RGJD-06?MCK?)	29,800 [8.7]	22,700 [6.7]	7,100 [2.1]	13.10	15.00	73	1,000 [472]
	RCQD-3621A* (RGJD-07?MCK?)	29,800 [8.7]	22,700 [6.7]	7,100 [2.1]	13.05	15.00	73	1,025 [484]
	RCQD-3621A* (RGPL-05?BMK?)	29,600 [8.7]	22,500 [6.6]	7,100 [2.1]	12.95	15.00	73	1,000 [472]
	RCQD-3621A* (RGPL-07?BRK?)	29,800 [8.7]	22,650 [6.6]	7,150 [2.1]	13.30	15.50	73	1,000 [472]
	RCQD-3621A* (RGPL-07?BRQ?)	30,000 [8.8]	22,850 [6.7]	7,150 [2.1]	13.75	16.00	73	1,000 [472]
	RCQD-3621A* (RGPR-05?BMK?)	29,600 [8.7]	22,500 [6.6]	7,100 [2.1]	12.95	15.00	73	1,000 [472]
	RCQD-3621A* (RGPR-07?AMK?)	29,800 [8.7]	22,650 [6.6]	7,150 [2.1]	13.30	15.50	73	1,000 [472]
	RCQD-3621A* (RGPR-07?BRQ?)	30,000 [8.8]	22,850 [6.7]	7,150 [2.1]	13.75	16.00	73	1,000 [472]
	RCQD-3624A*	29,200 [8.6]	22,200 [6.5]	7,000 [2.1]	12.20	14.00	73	1,000 [472]
	RCQD-3624A* (RGPL-07?BRQ?)	30,000 [8.8]	22,850 [6.7]	7,150 [2.1]	13.75	16.00	73	1,000 [472]
	RCQD-3624A* (RGPR-07?BRQ?)	30,000 [8.8]	22,850 [6.7]	7,150 [2.1]	13.75	16.00	73	1,000 [472]
	17AHSL30AU (RCSL-A*3617A*)	28,600 [8.4]	21,200 [6.2]	7,400 [2.2]	12.15	14.00	73	950 [448]
	17AHL36HM (RCSL-H*3617A*)	29,400 [8.6]	21,700 [6.4]	7,700 [2.3]	13.15	15.50	73	1,000 [472]
17AHSL30HM (RCSL-H*3617A*)	28,600 [8.4]	21,200 [6.2]	7,400 [2.2]	12.15	14.00	73	950 [448]	
RHKL-HM3617 (RCSL-H*3617A*)	29,400 [8.6]	21,700 [6.4]	7,700 [2.3]	13.15	15.50	73	1,000 [472]	
RHLL-HM3617 (RCSL-H*3617A*)	29,400 [8.6]	21,700 [6.4]	7,700 [2.3]	13.15	15.50	73	1,000 [472]	
RHSL-HM3017 (RCSL-H*3617A*)	28,600 [8.4]	21,200 [6.2]	7,400 [2.2]	12.15	14.00	73	950 [448]	
036JEZ	RCFL-H*3617A*+RXMD-C04 ①	35,000 [10.3]	25,300 [7.4]	9,700 [2.8]	12.00	14.00	73	1,075 [507]
	RCFL-A*3617B* (RGFD-07?MCK?)	35,000 [10.3]	25,250 [7.4]	9,750 [2.9]	12.35	14.50	73	1,000 [472]
	RCFL-A*3617B* (RGGD-06?MCK?)	35,000 [10.3]	25,250 [7.4]	9,750 [2.9]	12.40	14.50	73	1,000 [472]
	RCFL-A*3617B* (RGGD-07?MCK?)	35,000 [10.3]	25,350 [7.4]	9,650 [2.8]	12.35	14.50	73	1,025 [484]
	RCFL-A*3617B* (RGLR-07?AMK?)	35,200 [10.3]	25,450 [7.5]	9,750 [2.9]	12.65	14.50	73	1,025 [484]
	RCFL-A*3617B* (RGPR-07?AMK?)	35,000 [10.3]	25,350 [7.4]	9,650 [2.8]	12.55	14.50	73	1,000 [472]
	RCFL-A*3617B*+RXMD-C04	35,000 [10.3]	25,300 [7.4]	9,700 [2.8]	12.00	14.00	73	1,075 [507]
	RCFL-A*3621B* (RGFD-06?MCK?)	34,800 [10.2]	25,150 [7.4]	9,650 [2.8]	12.15	14.50	73	1,000 [472]
	RCFL-A*3621B* (RGFD-07?MCK?)	35,000 [10.3]	25,250 [7.4]	9,750 [2.9]	12.40	14.50	73	1,000 [472]
	RCFL-A*3621B* (RGFD-09?ZCM?)	35,800 [10.5]	25,850 [7.6]	9,950 [2.9]	12.60	14.50	73	1,150 [543]
	RCFL-A*3621B* (RGGD-06?MCK?)	35,000 [10.3]	25,300 [7.4]	9,700 [2.8]	12.45	14.50	73	1,000 [472]
	RCFL-A*3621B* (RGGD-07?MCK?)	35,000 [10.3]	25,350 [7.4]	9,650 [2.8]	12.40	14.50	73	1,025 [484]
	RCFL-A*3621B* (RGLR-07?AMK?)	35,200 [10.3]	25,500 [7.5]	9,700 [2.8]	12.70	15.00	73	1,025 [484]
	RCFL-A*3621B* (RGPR-05?BMK?)	35,000 [10.3]	25,250 [7.4]	9,750 [2.9]	12.30	14.50	73	1,000 [472]
	RCFL-A*3621B* (RGPR-07?AMK?)	35,000 [10.3]	25,350 [7.4]	9,650 [2.8]	12.60	14.50	73	1,000 [472]
	RCFL-A*3621B* (RGPR-07?BRQ?)	35,200 [10.3]	25,500 [7.5]	9,700 [2.8]	12.95	14.50	73	1,000 [472]
	RCFL-H*3617A* (RGFD-07?MCK?)	35,000 [10.3]	25,250 [7.4]	9,750 [2.9]	12.35	14.50	73	1,000 [472]
	RCFL-H*3617A* (RGGD-06?MCK?)	35,000 [10.3]	25,250 [7.4]	9,750 [2.9]	12.40	14.50	73	1,000 [472]
	RCFL-H*3617A* (RGGD-07?MCK?)	35,000 [10.3]	25,350 [7.4]	9,650 [2.8]	12.35	14.50	73	1,025 [484]

① Highest sales volume tested combination required by D.O.E. test procedures.

[] Designates Metric Conversions

Performance Data @ ARI Standard Conditions—Cooling: RAPL- JEZ (continued)

Outdoor Unit RAPL-	Model Numbers	80°F [26.5°C] DB/67°F [19.5°C] WB Indoor Air 95°F [35°C] DB Outdoor Air					Sound Rating dB	Indoor CFM [L/s]
		Total Capacity BTU/H [kW]	Net Sensible BTU/H [kW]	Net Latent BTU/H [kW]	EER	SEER		
036JEZ	RCFL-H*3617A* (RGJD-06?MCK?)	35,000 [10.3]	25,250 [7.4]	9,750 [2.9]	12.40	14.50	73	1,000 [472]
	RCFL-H*3617A* (RGJD-07?MCK?)	35,000 [10.3]	25,350 [7.4]	9,650 [2.8]	12.35	14.50	73	1,025 [484]
	RCFL-H*3617A* (RGLR-07?AMK?)	35,200 [10.3]	25,450 [7.5]	9,750 [2.9]	12.65	14.50	73	1,025 [484]
	RCFL-H*3617A* (RGPR-07?AMK?)	35,000 [10.3]	25,350 [7.4]	9,650 [2.8]	12.55	14.50	73	1,000 [472]
	RCFL-H*3621A* (RGFD-07?MCK?)	35,000 [10.3]	25,250 [7.4]	9,750 [2.9]	12.40	14.50	73	1,000 [472]
	RCFL-H*3621A* (RGFD-09?ZCM?)	35,800 [10.5]	25,850 [7.6]	9,950 [2.9]	12.60	14.50	73	1,150 [543]
	RCFL-H*3621A* (RGGD-06?MCK?)	35,000 [10.3]	25,300 [7.4]	9,700 [2.8]	12.45	14.50	73	1,000 [472]
	RCFL-H*3621A* (RGGD-07?MCK?)	35,000 [10.3]	25,350 [7.4]	9,650 [2.8]	12.40	14.50	73	1,025 [484]
	RCFL-H*3621A* (RGJD-06?MCK?)	35,000 [10.3]	25,300 [7.4]	9,700 [2.8]	12.45	14.50	73	1,000 [472]
	RCFL-H*3621A* (RGJD-07?MCK?)	35,000 [10.3]	25,350 [7.4]	9,650 [2.8]	12.40	14.50	73	1,025 [484]
	RCFL-H*3621A* (RGLR-07?AMK?)	35,200 [10.3]	25,500 [7.5]	9,700 [2.8]	12.70	15.00	73	1,025 [484]
	RCFL-H*3621A* (RGPR-05?BMK?)	35,000 [10.3]	25,250 [7.4]	9,750 [2.9]	12.30	14.50	73	1,000 [472]
	RCFL-H*3621A* (RGPR-07?AMK?)	35,000 [10.3]	25,350 [7.4]	9,650 [2.8]	12.60	14.50	73	1,000 [472]
	RCFL-H*3621A* (RGPR-07?BRQ?)	35,200 [10.3]	25,500 [7.5]	9,700 [2.8]	12.95	14.50	73	1,000 [472]
	RCFL-H*3621A*+RXMD-C04	35,000 [10.3]	25,300 [7.4]	9,700 [2.8]	12.00	14.00	73	1,075 [507]
	RCHL-36A1	33,600 [9.8]	23,950 [7.0]	9,650 [2.8]	11.15	13.00	73	1,200 [566]
	21AHBL36HM (RCHL-36A1)	34,800 [10.2]	24,750 [7.3]	10,050 [2.9]	12.35	14.50	73	1,225 [578]
	RBHK-21 (RCHL-36A1)	34,400 [10.1]	24,750 [7.3]	9,650 [2.8]	12.25	14.50	73	1,200 [566]
	RBHP-21 (RCHL-36A1)	34,800 [10.2]	24,750 [7.3]	10,050 [2.9]	12.35	14.50	73	1,225 [578]
	RCHL-36A1 (RGFD-09?ZCM?)	34,000 [10.0]	24,650 [7.2]	9,350 [2.7]	12.05	14.00	73	1,150 [543]
	RCHL-36A1 (RGFD-10?ZCM?)	34,200 [10.0]	24,500 [7.2]	9,700 [2.8]	11.95	14.00	73	1,175 [554]
	RCHL-36A1 (RGFD-12?RCM?)	34,200 [10.0]	24,600 [7.2]	9,600 [2.8]	12.05	14.00	73	1,225 [578]
	RCHL-36A1 (RGGD-09?ZCM?)	34,200 [10.0]	24,600 [7.2]	9,600 [2.8]	12.10	14.00	73	1,175 [554]
	RCHL-36A1 (RGGD-10?ZCM?)	34,200 [10.0]	24,650 [7.2]	9,550 [2.8]	12.10	14.00	73	1,175 [554]
	RCHL-36A1 (RGGD-12?RCM?)	34,400 [10.1]	24,700 [7.2]	9,700 [2.8]	12.20	14.00	73	1,225 [578]
	RCHL-36A1 (RGJD-09?ZCM?)	34,200 [10.0]	24,600 [7.2]	9,600 [2.8]	12.10	14.00	73	1,175 [554]
	RCHL-36A1 (RGJD-10?ZCM?)	34,200 [10.0]	24,650 [7.2]	9,550 [2.8]	12.10	14.00	73	1,175 [554]
	RCHL-36A1 (RGJD-12?RCM?)	34,400 [10.1]	24,700 [7.2]	9,700 [2.8]	12.20	14.00	73	1,225 [578]
	RCHL-36A1 (RGLR-07?AMK?)	34,000 [10.0]	24,400 [7.1]	9,600 [2.8]	11.80	13.50	73	1,200 [566]
	RCHL-36A1 (RGLR-10?BRM?)	34,400 [10.1]	24,700 [7.2]	9,700 [2.8]	12.25	14.50	73	1,200 [566]
	RCHL-36A1 (RGLR-12?ARM?)	34,400 [10.1]	24,750 [7.3]	9,650 [2.8]	12.30	14.50	73	1,225 [578]
	RCHL-36A1 (RGPR-07?AMK?)	34,000 [10.0]	24,400 [7.1]	9,600 [2.8]	11.80	13.50	73	1,200 [566]
	RCHL-36A1 (RGPR-07?BRQ?)	34,400 [10.1]	24,750 [7.3]	9,650 [2.8]	12.25	14.50	73	1,200 [566]
	RCHL-36A1 (RGPR-10?BRM?)	34,200 [10.0]	24,600 [7.2]	9,600 [2.8]	12.10	14.00	73	1,225 [578]
	RCHL-36A1 (RGPR-12?ARM?)	34,600 [10.1]	24,650 [7.2]	9,950 [2.9]	12.25	14.50	73	1,250 [590]
	RCHL-36A2	33,600 [9.8]	23,950 [7.0]	9,650 [2.8]	11.15	13.00	73	1,200 [566]
	RBHK-21 (RCHL-36A2)	34,800 [10.2]	24,750 [7.3]	10,050 [2.9]	12.40	14.50	73	1,200 [566]
	RCHL-36A2 (RGFD-09?ZCM?)	34,000 [10.0]	24,650 [7.2]	9,350 [2.7]	12.05	14.00	73	1,150 [543]
	RCHL-36A2 (RGFD-10?ZCM?)	34,200 [10.0]	24,500 [7.2]	9,700 [2.8]	11.95	14.00	73	1,175 [554]
	RCHL-36A2 (RGFD-12?RCM?)	34,200 [10.0]	24,600 [7.2]	9,600 [2.8]	12.05	14.00	73	1,225 [578]
	RCHL-36A2 (RGGD-09?ZCM?)	34,200 [10.0]	24,600 [7.2]	9,600 [2.8]	12.10	14.00	73	1,175 [554]
	RCHL-36A2 (RGGD-10?ZCM?)	34,200 [10.0]	24,650 [7.2]	9,550 [2.8]	12.10	14.00	73	1,175 [554]
	RCHL-36A2 (RGGD-12?RCM?)	34,400 [10.1]	24,700 [7.2]	9,700 [2.8]	12.20	14.00	73	1,225 [578]
	RCHL-36A2 (RGJD-09?ZCM?)	34,200 [10.0]	24,600 [7.2]	9,600 [2.8]	12.10	14.00	73	1,175 [554]
	RCHL-36A2 (RGJD-10?ZCM?)	34,200 [10.0]	24,650 [7.2]	9,550 [2.8]	12.10	14.00	73	1,175 [554]
	RCHL-36A2 (RGJD-12?RCM?)	34,400 [10.1]	24,700 [7.2]	9,700 [2.8]	12.20	14.00	73	1,225 [578]
	RCHL-36A2 (RGLR-07?AMK?)	34,000 [10.0]	24,400 [7.1]	9,600 [2.8]	11.80	13.50	73	1,200 [566]
	RCHL-36A2 (RGLR-10?BRM?)	34,400 [10.1]	24,700 [7.2]	9,700 [2.8]	12.25	14.50	73	1,200 [566]
	RCHL-36A2 (RGLR-12?ARM?)	34,400 [10.1]	24,750 [7.3]	9,650 [2.8]	12.30	14.50	73	1,225 [578]
	RCHL-36A2 (RGPR-07?AMK?)	34,000 [10.0]	24,400 [7.1]	9,600 [2.8]	11.80	13.50	73	1,200 [566]
RCHL-36A2 (RGPR-07?BRQ?)	34,400 [10.1]	24,750 [7.3]	9,650 [2.8]	12.25	14.50	73	1,200 [566]	
RCHL-36A2 (RGPR-10?BRM?)	34,200 [10.0]	24,600 [7.2]	9,600 [2.8]	12.10	14.00	73	1,225 [578]	
RCHL-36A2 (RGPR-12?ARM?)	34,600 [10.1]	24,650 [7.2]	9,950 [2.9]	12.25	14.50	73	1,250 [590]	
RCQD-3621A*	36,600 [10.7]	27,850 [8.2]	8,750 [2.6]	11.95	14.00	73	1,200 [566]	
RCQD-3621A* (RGFD-06?MCK?)	36,800 [10.8]	28,000 [8.2]	8,800 [2.6]	12.10	14.00	73	1,175 [554]	
RCQD-3621A* (RGFD-07?MCK?)	36,800 [10.8]	28,000 [8.2]	8,800 [2.6]	12.05	14.00	73	1,200 [566]	

① Highest sales volume tested combination required by D.O.E. test procedures.

[] Designates Metric Conversions

Performance Data @ ARI Standard Conditions—Cooling: RAPL- JEZ (continued)

Outdoor Unit RAPL-	Model Numbers Indoor Coil and/or Air Handler	80°F [26.5°C] DB/67°F [19.5°C] WB Indoor Air 95°F [35°C] DB Outdoor Air					Sound Rating dB	Indoor CFM [L/s]
		Total Capacity BTU/H [kW]	Net Sensible BTU/H [kW]	Net Latent BTU/H [kW]	EER	SEER		
036JEZ	RCQD-3621A* (RGFD-09?ZCM?)	37,200 [10.9]	28,000 [8.2]	9,200 [2.7]	12.90	15.00	73	1,150 [543]
	RCQD-3621A* (RGFD-10?ZCM?)	37,400 [11.0]	28,450 [8.3]	8,950 [2.6]	12.85	15.00	73	1,175 [554]
	RCQD-3621A* (RGJD-06?MCK?)	37,000 [10.8]	28,150 [8.2]	8,850 [2.6]	12.25	14.00	73	1,225 [578]
	RCQD-3621A* (RGJD-07?MCK?)	36,800 [10.8]	28,000 [8.2]	8,800 [2.6]	12.10	14.00	73	1,225 [578]
	RCQD-3621A* (RGJD-09?ZCM?)	37,400 [11.0]	28,450 [8.3]	8,950 [2.6]	13.00	15.00	73	1,175 [554]
	RCQD-3621A* (RGJD-10?ZCM?)	37,400 [11.0]	28,450 [8.3]	8,950 [2.6]	13.00	15.00	73	1,175 [554]
	RCQD-3621A* (RGPL-05?BMK?)	36,800 [10.8]	27,950 [8.2]	8,850 [2.6]	12.15	14.00	73	1,200 [566]
	RCQD-3621A* (RGPL-07?BRK?)	37,200 [10.9]	28,300 [8.3]	8,900 [2.6]	12.65	14.50	73	1,200 [566]
	RCQD-3621A* (RGPL-07?BRQ?)	37,600 [11.0]	28,600 [8.4]	9,000 [2.6]	13.15	15.50	73	1,200 [566]
	RCQD-3621A* (RGPL-10?BRM?)	37,400 [11.0]	28,450 [8.3]	8,950 [2.6]	12.95	15.00	73	1,225 [578]
	RCQD-3621A* (RGPR-05?BMK?)	36,800 [10.8]	27,950 [8.2]	8,850 [2.6]	12.15	14.00	73	1,200 [566]
	RCQD-3621A* (RGPR-07?AMK?)	37,200 [10.9]	28,300 [8.3]	8,900 [2.6]	12.65	14.50	73	1,200 [566]
	RCQD-3621A* (RGPR-07?BRQ?)	37,600 [11.0]	28,600 [8.4]	9,000 [2.6]	13.15	15.50	73	1,200 [566]
	RCQD-3621A* (RGPR-10?BRM?)	37,400 [11.0]	28,450 [8.3]	8,950 [2.6]	12.95	15.00	73	1,225 [578]
	RCQD-3624A*	36,600 [10.7]	27,850 [8.2]	8,750 [2.6]	11.95	14.00	73	1,200 [566]
	RCQD-3624A* (RGFD-09?ZCM?)	37,200 [10.9]	28,000 [8.2]	9,200 [2.7]	12.90	15.00	73	1,150 [543]
	RCQD-3624A* (RGFD-10?ZCM?)	37,400 [11.0]	28,450 [8.3]	8,950 [2.6]	12.85	15.00	73	1,175 [554]
	RCQD-3624A* (RGFD-12?RCM?)	37,400 [11.0]	28,450 [8.3]	8,950 [2.6]	12.95	15.00	73	1,225 [578]
	RCQD-3624A* (RGJD-09?ZCM?)	37,400 [11.0]	28,450 [8.3]	8,950 [2.6]	13.00	15.00	73	1,175 [554]
	RCQD-3624A* (RGJD-10?ZCM?)	37,400 [11.0]	28,450 [8.3]	8,950 [2.6]	13.00	15.00	73	1,175 [554]
	RCQD-3624A* (RGJD-12?RCM?)	37,400 [11.0]	28,450 [8.3]	8,950 [2.6]	13.10	15.50	73	1,225 [578]
	RCQD-3624A* (RGPL-07?BRQ?)	37,600 [11.0]	28,600 [8.4]	9,000 [2.6]	13.15	15.50	73	1,200 [566]
	RCQD-3624A* (RGPL-10?BRM?)	37,400 [11.0]	28,450 [8.3]	8,950 [2.6]	12.95	15.00	73	1,225 [578]
	RCQD-3624A* (RGPL-12?ARM?)	37,800 [11.1]	29,100 [8.5]	8,700 [2.5]	13.15	15.50	73	1,250 [590]
	17AHSL36AU (RCSL-A*3617A*)	34,600 [10.1]	25,000 [7.3]	9,600 [2.8]	12.15	14.00	73	950 [448]
	17AHL36HM (RCSL-H*3617A*)	35,200 [10.3]	25,500 [7.5]	9,700 [2.8]	12.95	15.00	73	1,000 [472]
	17AHS36HM (RCSL-H*3617A*)	34,600 [10.1]	25,000 [7.3]	9,600 [2.8]	12.15	14.00	73	950 [448]
	RHKL-HM3617 (RCSL-H*3617A*)	35,400 [10.4]	25,550 [7.5]	9,850 [2.9]	12.90	15.00	73	1,025 [484]
	RHLL-HM3617 (RCSL-H*3617A*)	35,200 [10.3]	25,500 [7.5]	9,700 [2.8]	12.95	15.00	73	1,000 [472]
	RHSL-HM3617 (RCSL-H*3617A*)	34,600 [10.1]	25,000 [7.3]	9,600 [2.8]	12.15	14.00	73	950 [448]
	RHSL-HM3621 (RCSL-H*3621A*)	34,600 [10.1]	25,000 [7.3]	9,600 [2.8]	12.15	14.00	73	950 [448]
	042JEZ	RCFL-H*4821A*+RXMD-C04 ①	42,000 [12.3]	29,800 [8.7]	12,200 [3.6]	12.05	14.00	76
RCFL-A*4821B* (RGLR-10?BRM?)		43,000 [12.6]	30,500 [8.9]	12,500 [3.7]	12.80	14.50	76	1,375 [649]
RCFL-A*4821B* (RGPR-10?BRM?)		42,500 [12.5]	30,000 [8.8]	12,500 [3.7]	12.85	14.50	76	1,225 [578]
RCFL-A*4821B*+RXMD-C04		42,000 [12.3]	29,800 [8.7]	12,200 [3.6]	12.05	14.00	76	1,300 [613]
RCFL-A*4824B* (RGFD-12?RCM?)		42,500 [12.5]	30,000 [8.8]	12,500 [3.7]	12.80	14.50	76	1,225 [578]
RCFL-A*4824B* (RGGD-12?RCM?)		42,500 [12.5]	30,050 [8.8]	12,450 [3.6]	12.90	15.00	76	1,225 [578]
RCFL-A*4824B* (RGLR-10?BRM?)		43,000 [12.6]	30,500 [8.9]	12,500 [3.7]	12.80	14.50	76	1,375 [649]
RCFL-A*4824B* (RGLR-12?ARM?)		42,500 [12.5]	30,100 [8.8]	12,400 [3.6]	13.05	15.00	76	1,225 [578]
RCFL-A*4824B* (RGPR-10?BRM?)		42,500 [12.5]	30,000 [8.8]	12,500 [3.7]	12.85	14.50	76	1,225 [578]
RCFL-A*4824B* (RGPR-12?ARM?)		42,500 [12.5]	30,150 [8.8]	12,350 [3.6]	12.95	15.00	76	1,250 [590]
RCFL-H*4821A* (RGLR-10?BRM?)		43,000 [12.6]	30,500 [8.9]	12,500 [3.7]	12.80	14.50	76	1,375 [649]
RCFL-H*4821A* (RGPR-10?BRM?)		42,500 [12.5]	30,000 [8.8]	12,500 [3.7]	12.85	14.50	76	1,225 [578]
RCFL-H*4824A* (RGFD-12?RCM?)		42,500 [12.5]	30,000 [8.8]	12,500 [3.7]	12.80	14.50	76	1,225 [578]
RCFL-H*4824A* (RGGD-12?RCM?)		42,500 [12.5]	30,050 [8.8]	12,450 [3.6]	12.90	15.00	76	1,225 [578]
RCFL-H*4824A* (RGJD-12?RCM?)		42,500 [12.5]	30,050 [8.8]	12,450 [3.6]	12.95	15.00	76	1,225 [578]
RCFL-H*4824A* (RGLR-10?BRM?)		43,000 [12.6]	30,500 [8.9]	12,500 [3.7]	12.80	14.50	76	1,375 [649]
RCFL-H*4824A* (RGLR-12?ARM?)		42,500 [12.5]	30,100 [8.8]	12,400 [3.6]	13.05	15.00	76	1,225 [578]
RCFL-H*4824A* (RGPR-10?BRM?)		42,500 [12.5]	30,000 [8.8]	12,500 [3.7]	12.85	14.50	76	1,225 [578]
RCFL-H*4824A* (RGPR-12?ARM?)		42,500 [12.5]	30,150 [8.8]	12,350 [3.6]	12.95	15.00	76	1,250 [590]
RCFL-H*4824A*+RXMD-C04		42,000 [12.3]	29,800 [8.7]	12,200 [3.6]	12.05	14.00	76	1,300 [613]
RCHL-48A1		42,000 [12.3]	29,800 [8.7]	12,200 [3.6]	12.05	13.00	76	1,300 [613]
24AHL48HM (RCHL-48A1)		40,500 [11.9]	28,000 [8.2]	12,500 [3.7]	12.40	14.50	76	1,400 [661]
RBHK-24 (RCHL-48A1)		40,500 [11.9]	28,000 [8.2]	12,500 [3.7]	12.30	14.50	76	1,400 [661]
RBHP-24 (RCHL-48A1)		40,500 [11.9]	28,000 [8.2]	12,500 [3.7]	12.40	14.50	76	1,400 [661]
RCHL-48A1 (RGFD-10?ZCM?)		39,500 [11.6]	28,000 [8.2]	11,500 [3.4]	11.70	13.50	76	1,325 [625]

① Highest sales volume tested combination required by D.O.E. test procedures.

[] Designates Metric Conversions

Performance Data @ ARI Standard Conditions—Cooling: RAPL- JEZ (continued)

Outdoor Unit RAPL-	Model Numbers Indoor Coil and/or Air Handler	80°F [26.5°C] DB/67°F [19.5°C] WB Indoor Air 95°F [35°C] DB Outdoor Air					Sound Rating dB	Indoor CFM [L/s]
		Total Capacity BTU/H [kW]	Net Sensible BTU/H [kW]	Net Latent BTU/H [kW]	EER	SEER		
042JEZ	RCHL-48A1 (RGFD-12?RCM?)	39,500 [11.6]	27,850 [8.2]	11,650 [3.4]	11.55	13.50	76	1,325 [625]
	RCHL-48A1 (RGGD-09?ZCM?)	40,000 [11.7]	28,150 [8.2]	11,850 [3.5]	12.05	13.50	76	1,400 [661]
	RCHL-48A1 (RGGD-10?ZCM?)	40,000 [11.7]	27,850 [8.2]	12,150 [3.6]	11.65	13.50	76	1,425 [672]
	RCHL-48A1 (RGGD-12?RCM?)	40,000 [11.7]	27,900 [8.2]	12,100 [3.5]	11.70	14.00	76	1,425 [672]
	RCHL-48A1 (RGJD-10?ZCM?)	40,000 [11.7]	27,850 [8.2]	12,150 [3.6]	11.65	13.50	76	1,425 [672]
	RCHL-48A1 (RGJD-12?RCM?)	40,000 [11.7]	27,900 [8.2]	12,100 [3.5]	11.70	14.00	76	1,425 [672]
	RCHL-48A1 (RGLR-10?BRM?)	40,500 [11.9]	28,000 [8.2]	12,500 [3.7]	11.95	14.00	76	1,450 [684]
	RCHL-48A1 (RGLR-12?ARM?)	40,000 [11.7]	28,200 [8.3]	11,800 [3.5]	12.10	14.00	76	1,375 [649]
	RCHL-48A1 (RGPR-07?BRQ?)	40,000 [11.7]	28,150 [8.2]	11,850 [3.5]	12.05	14.00	76	1,400 [661]
	RCHL-48A1 (RGPR-12?ARM?)	40,000 [11.7]	27,950 [8.2]	12,050 [3.5]	11.80	14.00	76	1,425 [672]
	RCQD-4821A*	42,500 [12.5]	30,850 [9.0]	11,650 [3.4]	12.40	14.50	76	1,400 [661]
	RCQD-4821A* (RGPL-07?BRQ?)	43,000 [12.6]	31,300 [9.2]	11,700 [3.4]	13.10	15.00	76	1,400 [661]
	RCQD-4821A* (RGPR-07?BRQ?)	43,000 [12.6]	31,300 [9.2]	11,700 [3.4]	13.10	15.00	76	1,400 [661]
	RCQD-4824A*	42,500 [12.5]	30,850 [9.0]	11,650 [3.4]	12.40	14.50	76	1,400 [661]
	RCQD-4824A* (RGJD-12?RCM?)	43,000 [12.6]	31,600 [9.3]	11,400 [3.3]	12.95	15.00	76	1,450 [684]
	RCQD-4824A* (RGPL-07?BRQ?)	43,000 [12.6]	31,300 [9.2]	11,700 [3.4]	13.10	15.00	76	1,400 [661]
	RCQD-4824A* (RGPL-12?ARM?)	43,000 [12.6]	31,300 [9.2]	11,700 [3.4]	13.10	15.00	76	1,400 [661]
	RCQD-4824A* (RGPR-07?BRQ?)	43,000 [12.6]	31,300 [9.2]	11,700 [3.4]	13.10	15.00	76	1,400 [661]
	RCQD-4824A* (RGPR-12?ARM?)	43,000 [12.6]	31,300 [9.2]	11,700 [3.4]	13.10	15.00	76	1,400 [661]
	21AHS42AU (RCSL-A*4821A*)	42,500 [12.5]	30,000 [8.8]	12,500 [3.7]	12.00	13.00	76	1,350 [637]
	21AHL48HM (RCSL-H*4821A*)	43,500 [12.7]	30,750 [9.0]	12,750 [3.7]	13.05	15.00	76	1,400 [661]
	21AHS42HM (RCSL-H*4821A*)	42,500 [12.5]	30,000 [8.8]	12,500 [3.7]	12.00	13.00	76	1,350 [637]
	RHKL-HM4821 (RCSL-H*4821A*)	43,500 [12.7]	30,700 [9.0]	12,800 [3.8]	13.00	15.00	76	1,400 [661]
	RHLL-HM4821 (RCSL-H*4821A*)	43,500 [12.7]	30,750 [9.0]	12,750 [3.7]	13.05	15.00	76	1,400 [661]
RHSL-HM4221 (RCSL-H*4821A*)	42,500 [12.5]	30,000 [8.8]	12,500 [3.7]	12.00	13.00	76	1,350 [637]	
048JEZ	RCFL-H*4821A* ①	48,500 [14.2]	34,300 [10.0]	14,200 [4.2]	12.00	14.00	76	1,475 [696]
	RCFL-A*4821B*	48,500 [14.2]	34,300 [10.0]	14,200 [4.2]	12.00	14.00	76	1,475 [696]
	RCFL-A*4821B* (RGLR-10?BRM?)	49,000 [14.4]	34,750 [10.2]	14,250 [4.2]	12.15	14.50	76	1,575 [743]
	RCFL-A*4821B* (RGPR-07?BRQ?)	48,500 [14.2]	34,300 [10.0]	14,200 [4.2]	12.45	14.50	76	1,400 [661]
	RCFL-A*4821B* (RGPR-10?BRM?)	48,500 [14.2]	34,300 [10.0]	14,200 [4.2]	12.25	14.50	76	1,425 [672]
	RCFL-A*4824B*	48,500 [14.2]	34,300 [10.0]	14,200 [4.2]	12.00	14.00	76	1,475 [696]
	RCFL-A*4824B* (RGGD-12?RCM?)	49,000 [14.4]	34,550 [10.1]	14,450 [4.2]	12.40	14.50	76	1,450 [684]
	RCFL-A*4824B* (RGLR-12?ARM?)	48,500 [14.2]	34,400 [10.1]	14,100 [4.1]	12.50	14.50	76	1,425 [672]
	RCFL-A*4824B* (RGPR-07?BRQ?)	48,500 [14.2]	34,300 [10.0]	14,200 [4.2]	12.45	14.50	76	1,400 [661]
	RCFL-A*4824B* (RGPR-10?BRM?)	48,500 [14.2]	34,250 [10.0]	14,250 [4.2]	12.25	14.50	76	1,425 [672]
	RCFL-A*4824B* (RGPR-12?ARM?)	49,000 [14.4]	34,750 [10.2]	14,250 [4.2]	12.20	14.50	76	1,575 [743]
	RCFL-H*4821A* (RGLR-10?BRM?)	49,000 [14.4]	34,750 [10.2]	14,250 [4.2]	12.15	14.50	76	1,575 [743]
	RCFL-H*4821A* (RGPR-07?BRQ?)	48,500 [14.2]	34,300 [10.0]	14,200 [4.2]	12.45	14.50	76	1,400 [661]
	RCFL-H*4821A* (RGPR-10?BRM?)	48,500 [14.2]	34,300 [10.0]	14,200 [4.2]	12.25	14.50	76	1,425 [672]
	RCFL-H*4824A*	48,500 [14.2]	34,300 [10.0]	14,200 [4.2]	12.00	14.00	76	1,475 [696]
	RCFL-H*4824A* (RGGD-12?RCM?)	49,000 [14.4]	34,550 [10.1]	14,450 [4.2]	12.40	14.50	76	1,450 [684]
	RCFL-H*4824A* (RGJD-12?RCM?)	49,000 [14.4]	34,550 [10.1]	14,450 [4.2]	12.40	14.50	76	1,450 [684]
	RCFL-H*4824A* (RGLR-12?ARM?)	48,500 [14.2]	34,400 [10.1]	14,100 [4.1]	12.50	14.50	76	1,425 [672]
	RCFL-H*4824A* (RGPR-07?BRQ?)	48,500 [14.2]	34,300 [10.0]	14,200 [4.2]	12.45	14.50	76	1,400 [661]
	RCFL-H*4824A* (RGPR-10?BRM?)	48,500 [14.2]	34,250 [10.0]	14,250 [4.2]	12.25	14.50	76	1,425 [672]
	RCFL-H*4824A* (RGPR-12?ARM?)	49,000 [14.4]	34,750 [10.2]	14,250 [4.2]	12.20	14.50	76	1,575 [743]
	RCHL-48A1	45,500 [13.3]	31,350 [9.2]	14,150 [4.1]	10.85	13.00	76	1,600 [755]
	24AHL48HM (RCHL-48A1)	46,000 [13.5]	31,700 [9.3]	14,300 [4.2]	11.60	14.00	76	1,600 [755]
	RBHK-24 (RCHL-48A1)	46,500 [13.6]	32,150 [9.4]	14,350 [4.2]	11.65	14.00	76	1,600 [755]
	RBHP-24 (RCHL-48A1)	46,000 [13.5]	31,700 [9.3]	14,300 [4.2]	11.60	14.00	76	1,600 [755]
	RCHL-48A1 (RGFD-12?RCM?)	46,000 [13.5]	31,600 [9.3]	14,400 [4.2]	11.15	13.50	76	1,650 [779]
	RCHL-48A1 (RGGD-12?RCM?)	46,000 [13.5]	31,550 [9.2]	14,450 [4.2]	11.10	13.50	76	1,650 [779]
	RCHL-48A1 (RGJD-12?RCM?)	46,000 [13.5]	31,550 [9.2]	14,450 [4.2]	11.10	13.50	76	1,650 [779]
	RCHL-48A1 (RGLR-10?BRM?)	46,000 [13.5]	31,850 [9.3]	14,150 [4.1]	11.35	13.50	76	1,575 [743]
	RCHL-48A1 (RGLR-12?ARM?)	46,000 [13.5]	31,900 [9.3]	14,100 [4.1]	11.40	13.50	76	1,600 [755]
	RCHL-48A1 (RGPR-07?BRQ?)	46,000 [13.5]	31,800 [9.3]	14,200 [4.2]	11.30	13.00	76	1,625 [767]

① Highest sales volume tested combination required by D.O.E. test procedures.

[] Designates Metric Conversions

Performance Data @ ARI Standard Conditions—Cooling: RAPL- JEZ (continued)

Outdoor Unit RAPL-	Model Numbers Indoor Coil and/or Air Handler	80°F [26.5°C] DB/67°F [19.5°C] WB Indoor Air 95°F [35°C] DB Outdoor Air					Sound Rating dB	Indoor CFM [L/s]
		Total Capacity BTU/H [kW]	Net Sensible BTU/H [kW]	Net Latent BTU/H [kW]	EER	SEER		
048JEZ	RCHL-48A1 (RGPR-10?BRM?)	45,500 [13.3]	31,600 [9.3]	13,900 [4.1]	11.10	13.50	76	1,625 [767]
	RCHL-48A1 (RGPR-12?ARM?)	46,000 [13.5]	31,900 [9.3]	14,100 [4.1]	11.40	13.50	76	1,575 [743]
	RCHL-48A2	45,500 [13.3]	31,350 [9.2]	14,150 [4.1]	10.85	13.00	76	1,600 [755]
	24AHBL48HM (RCHL-48A2)	47,000 [13.8]	32,500 [9.5]	14,500 [4.2]	11.80	14.00	76	1,700 [802]
	RBHK-24 (RCHL-48A2)	46,000 [13.5]	31,700 [9.3]	14,300 [4.2]	11.50	14.00	76	1,600 [755]
	RCHL-48A2 (RGFD-12?RCM?)	46,000 [13.5]	31,600 [9.3]	14,400 [4.2]	11.15	13.50	76	1,650 [779]
	RCHL-48A2 (RGGD-12?RCM?)	46,000 [13.5]	31,550 [9.2]	14,450 [4.2]	11.10	13.50	76	1,650 [779]
	RCHL-48A2 (RGJD-12?RCM?)	46,000 [13.5]	31,550 [9.2]	14,450 [4.2]	11.10	13.50	76	1,650 [779]
	RCHL-48A2 (RGLR-10?BRM?)	46,000 [13.5]	31,850 [9.3]	14,150 [4.1]	11.35	13.50	76	1,575 [743]
	RCHL-48A2 (RGLR-12?ARM?)	46,000 [13.5]	31,900 [9.3]	14,100 [4.1]	11.40	13.50	76	1,600 [755]
	RCHL-48A2 (RGPR-10?BRM?)	45,500 [13.3]	31,600 [9.3]	13,900 [4.1]	11.10	13.50	76	1,625 [767]
	RCHL-48A2 (RGPR-12?ARM?)	46,000 [13.5]	31,900 [9.3]	14,100 [4.1]	11.40	13.50	76	1,575 [743]
	RCQD-4821A*	47,000 [13.8]	34,350 [10.1]	12,650 [3.7]	11.15	13.50	76	1,600 [755]
	RCQD-4821A* (RGPL-07?BRQ?)	47,000 [13.8]	34,300 [10.0]	12,700 [3.7]	11.40	14.00	76	1,625 [767]
	RCQD-4821A* (RGPR-07?BRQ?)	47,000 [13.8]	34,300 [10.0]	12,700 [3.7]	11.40	14.00	76	1,625 [767]
	RCQD-4824A*	47,000 [13.8]	34,350 [10.1]	12,650 [3.7]	11.15	13.50	76	1,600 [755]
	RCQD-4824A* (RGPL-07?BRQ?)	47,000 [13.8]	34,300 [10.0]	12,700 [3.7]	11.40	14.00	76	1,625 [767]
	RCQD-4824A* (RGPL-12?ARM?)	47,500 [13.9]	34,750 [10.2]	12,750 [3.7]	11.50	14.00	76	1,575 [743]
	RCQD-4824A* (RGPR-07?BRQ?)	47,000 [13.8]	34,300 [10.0]	12,700 [3.7]	11.40	14.00	76	1,625 [767]
	RCQD-4824A* (RGPR-12?ARM?)	47,500 [13.9]	34,750 [10.2]	12,750 [3.7]	11.50	14.00	76	1,575 [743]
	21AHL48HM (RCSL-H*4821A*)	49,000 [14.4]	34,500 [10.1]	14,500 [4.2]	12.75	15.00	76	1,400 [661]
	21AHL48HM (RCSL-H*4821A*)	48,500 [14.2]	34,450 [10.1]	14,050 [4.1]	11.95	14.00	76	1,525 [720]
	24AHL48HM (RCSL-H*4821A*)	48,500 [14.2]	34,450 [10.1]	14,050 [4.1]	11.95	14.00	76	1,525 [720]
	RHKL-HM4821 (RCSL-H*4821A*)	49,500 [14.5]	34,900 [10.2]	14,600 [4.3]	12.45	15.00	76	1,575 [743]
	RHLL-HM4821 (RCSL-H*4821A*)	49,000 [14.4]	34,500 [10.1]	14,500 [4.2]	12.75	15.00	76	1,400 [661]
	RHSL-HM4821 (RCSL-H*4821A*)	48,500 [14.2]	34,450 [10.1]	14,050 [4.1]	11.95	14.00	76	1,525 [720]
	24AHL48HM (RCSL-H*4824A*)	49,000 [14.4]	34,500 [10.1]	14,500 [4.2]	12.75	15.00	76	1,400 [661]
	RHKL-HM4824 (RCSL-H*4824A*)	49,500 [14.5]	34,900 [10.2]	14,600 [4.3]	12.45	15.00	76	1,575 [743]
RHLL-HM4824 (RCSL-H*4824A*)	49,000 [14.4]	34,500 [10.1]	14,500 [4.2]	12.75	15.00	76	1,400 [661]	
RHSL-HM4824 (RCSL-H*4824A*)	48,500 [14.2]	34,450 [10.1]	14,050 [4.1]	11.95	14.00	76	1,525 [720]	
060JEZ	RCFL-H*6024A*+RXMD-C04 ①	58,500 [17.1]	41,500 [12.2]	17,000 [5.0]	11.70	14.00	76	1,750 [826]
	RCFL-A*6024B*+RXMD-C04	58,500 [17.1]	41,500 [12.2]	17,000 [5.0]	11.70	14.00	76	1,750 [826]
	25AHBL60HM (RCHL-60A1)	54,500 [16.0]	35,600 [10.4]	18,900 [5.5]	11.50	13.00	76	1,800 [849]
	RBHK-25 (RCHL-60A1)	55,000 [16.1]	35,900 [10.5]	19,100 [5.6]	11.85	13.50	76	1,800 [849]
	RBHP-25 (RCHL-60A1)	54,500 [16.0]	35,600 [10.4]	18,900 [5.5]	11.50	13.00	76	1,800 [849]
	RCQD-6024A*	56,500 [16.6]	39,700 [11.6]	16,800 [4.9]	11.35	13.50	76	1,800 [849]
	24AHL60HM (RCSL-H*6024A*)	59,500 [17.4]	42,100 [12.3]	17,400 [5.1]	12.45	14.50	76	1,800 [849]
	RHKL-HM6024 (RCSL-H*6024A*)	59,500 [17.4]	42,100 [12.3]	17,400 [5.1]	12.40	14.50	76	1,800 [849]
	RHLL-HM6024 (RCSL-H*6024A*)	59,500 [17.4]	42,100 [12.3]	17,400 [5.1]	12.45	14.50	76	1,800 [849]
	RHSL-HM6024 (RCSL-H*6024A*)	58,500 [17.1]	41,400 [12.1]	17,100 [5.0]	11.50	13.00	76	1,800 [849]

① Highest sales volume tested combination required by D.O.E. test procedures.

[] Designates Metric Conversions

Electrical and Physical Data: RAPL- JEZ

Model No. RAPL-	ELECTRICAL							PHYSICAL					
	Phase Hertz Volts	Compr. RLA	Compr. LRA	Fan Motor FLA	Min. Circuit Ampacity Amps	Fuse or HACR Circuit Breaker		Outdoor Coil			Refrig. Per Circuit Oz. [g]	Weight	
						Min. Amps	Max. Amps	Face Area Sq. Ft. [m ²]	No. Rows	CFM [L/s]		Net Lbs. [kg]	Shipping Lbs. [kg]
018JEZ	1-60-208/230	9/9	48	0.8	13/13	15/15	20/20	11.00 [1.02]	1	1900 [897]	79 [2240]	140 [63.5]	155 [70.3]
024JEZ	1-60-208/230	13.5/13.5	58.3	0.8	18/18	25/25	30/30	11.00 [1.02]	1	2300 [1085]	105 [2977]	140 [63.5]	187 [84.8]
030JEZ	1-60-208/230	12.8/12.8	64	1.2	18/18	25/25	30/30	20.00 [1.86]	1	3200 [1510]	135 [3827]	200 [90.7]	213 [96.6]
036JEZ	1-60-208/230	16.7/16.7	79	1.2	23/23	30/30	35/35	23.01 [2.14]	1	3200 [1510]	141 [3997]	230 [104.3]	228 [103.4]
042JEZ	1-60-208/230	17.9/17.9	112	1.2	24/24	30/30	40/40	23.01 [2.14]	1	3200 [1510]	152 [4309]	230 [104.3]	252 [114.3]
048JEZ	1-60-208/230	21.8/21.8	117	1.2	29/29	35/35	50/50	23.01 [2.14]	1	3300 [1557]	152 [4309]	230 [104.3]	253 [114.8]
060JEZ	1-60-208/230	26.4/26.4	134	1.2	35/35	45/45	60/60	44.00 [4.09]	2	3100 [1463]	286 [8108]	280 [127]	305 [138.3]

[] Designates Metric Conversions

Unit Dimensions

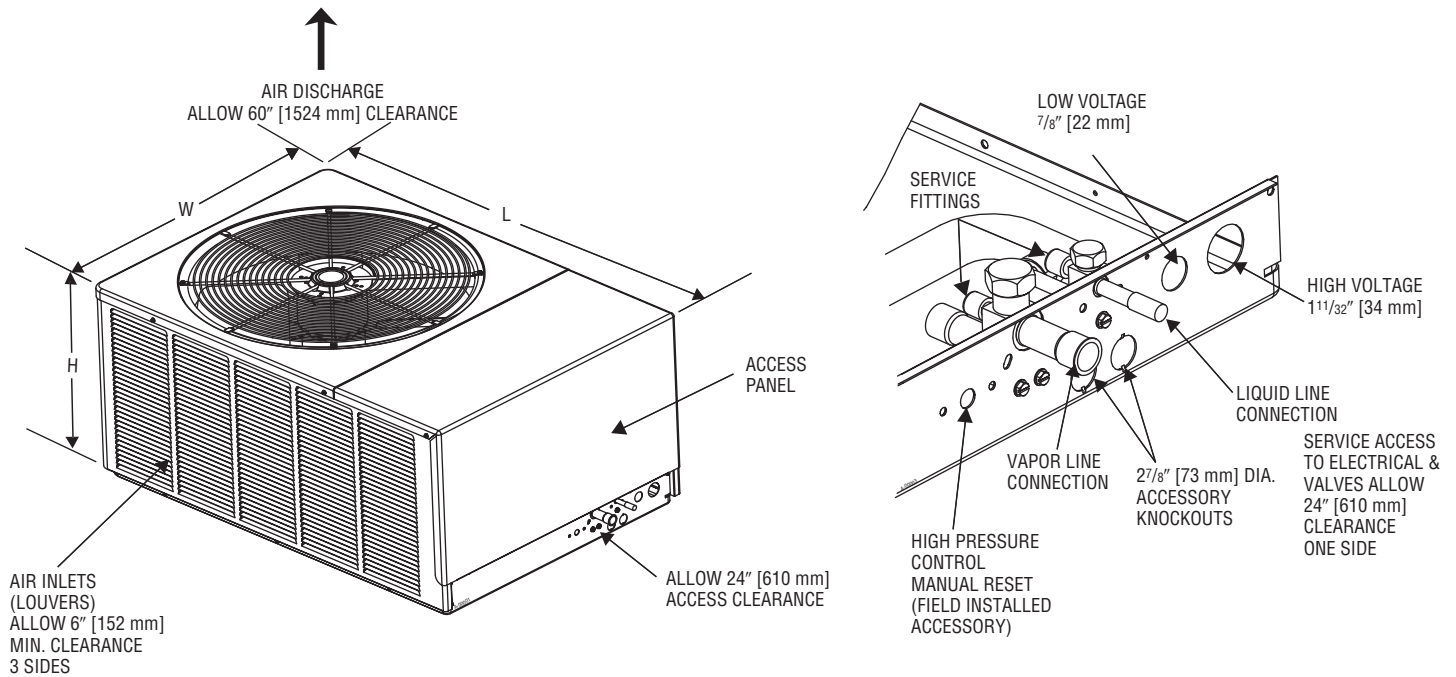

Model Number RAPL-	Height "H" (Inches) [mm]	Length "L" (Inches) [mm]	Width "W" (Inches) [mm]
018JEZ/024JEZ	19 [483]	40 1/2 [1029]	27 5/8 [702]
030JEZ	29 [737]	44 3/8 [1127]	31 1/2 [800]
036JEZ/042JEZ/ 048JEZ/060JEZ	33 [838]	44 3/8 [1127]	31 1/2 [800]

Condensing Unit Refrigerant Line Size Information

Liquid Line Sizing (R-410A)														
System Capacity	Line Size Connection (Inch I.D.)	Line Size (Inch O.D.) [mm]	Liquid Line Size – Outdoor Unit Above Indoor Coil (Cooling Only – Does not apply to Heat Pumps)						Liquid Line Size – Outdoor Unit Below Indoor Coil					
			Total Equivalent Length—Feet [m]						Total Equivalent Length—Feet [m]					
			25 [7.62]	50 [15.24]	75 [22.86]	100 [30.48]	125 [38.10]	150 [45.72]	25 [7.62]	50 [15.24]	75 [22.86]	100 [30.48]	125 [38.10]	150 [45.72]
			Minimum Vertical Separation—Feet [m]						Maximum Vertical Separation—Feet [m]					
1 1/2 Ton	3/8"	1/4 [6.35]	0	0	0	0	8 [2.44]	24 [7.32]	25 [7.62]	40 [12.19]	25 [7.62]	9 [2.74]	N/A	N/A
		5/16 [7.94]	0	0	0	0	0	0	25 [7.62]	50 [15.24]	62 [18.90]	58 [17.68]	53 [16.15]	49 [14.94]
		3/8* [9.53]	0	0	0	0	0	0	25 [7.62]	50 [15.24]	75 [22.86]	72 [21.95]	70 [21.34]	68 [20.73]
2 Ton	3/8"	1/4 [6.35]	0	3 [0.91]	29 [8.84]	55 [16.76]	81 [24.69]	108 [32.92]	23 [7.01]	N/A	N/A	N/A	N/A	N/A
		5/16 [7.94]	0	0	0	0	0	0	25 [7.62]	36 [10.97]	29 [8.84]	23 [7.01]	16 [4.88]	9 [2.74]
		3/8* [9.53]	0	0	0	0	0	0	25 [7.62]	50 [15.24]	72 [21.95]	70 [21.34]	68 [20.73]	65 [19.81]
2 1/2 Ton	3/8"	1/4 [6.35]	0	14 [4.27]	56 [17.07]	98 [29.87]	N/A	N/A	25 [7.62]	N/A	N/A	N/A	N/A	N/A
		5/16 [7.94]	0	0	0	0	0	0	25 [7.62]	49 [14.94]	38 [11.58]	27 [8.23]	17 [5.18]	6 [1.83]
		3/8* [9.53]	0	0	0	0	0	0	25 [7.62]	50 [15.24]	68 [20.73]	65 [19.81]	62 [18.90]	58 [17.68]
3 Ton	3/8"	5/16 [7.94]	0	0	0	0	0	9 [2.74]	25 [7.62]	50 [15.24]	37 [11.28]	22 [6.71]	7 [2.13]	N/A
		3/8* [9.53]	0	0	0	0	0	0	25 [7.62]	50 [15.24]	68 [20.73]	63 [19.20]	58 [17.68]	53 [16.15]
3 1/2 Ton	3/8"	5/16 [7.94]	0	0	0	16 [4.88]	35 [10.67]	54 [16.46]	25 [7.62]	23 [7.01]	4 [1.22]	N/A	N/A	N/A
		3/8* [9.53]	0	0	0	0	0	0	25 [7.62]	50 [15.24]	43 [13.11]	36 [10.97]	30 [9.14]	24 [7.32]
4 Ton	3/8"	3/8* [9.53]	0	0	0	0	0	0	25 [7.62]	46 [14.02]	38 [11.58]	30 [9.14]	22 [6.71]	15 [4.57]
		1/2 [12.57]	0	0	0	0	0	0	25 [7.62]	50 [15.24]	56 [17.07]	55 [16.76]	53 [16.15]	52 [15.85]
5 Ton	3/8"	3/8* [9.53]	0	0	0	0	0	0	25 [7.62]	50 [15.24]	56 [17.07]	44 [13.41]	32 [9.75]	20 [6.10]
		1/2 [12.57]	0	0	0	0	0	0	25 [7.62]	50 [15.24]	75 [22.86]	81 [24.69]	79 [24.08]	76 [23.16]

NOTES: *Standard line size
N/A = Application not recommended.

Suction Line Length/Size versus Capacity Multiplier (R-410A)									
Unit Size	1 1/2 Ton	2 Ton	2 1/2 Ton		3 Ton	3 1/2 Ton	4 Ton	5 Ton	
Suction Line Connection Size	3/4" [19.05 mm] I.D.				7/8" [22.23 mm] I.D.				
Suction Line Run—Feet [m]	5/8" [15.88 mm] O.D. Opt. 3/4" [19.05 mm] O.D. Std.*	5/8" [15.88 mm] O.D. Opt. 3/4" [19.05 mm] O.D. Std.* 7/8" [22.23 mm] O.D. Opt.	3/4" [19.05 mm] O.D. Opt. 7/8" [22.23 mm] O.D. Std.*		7/8" [22.23 mm] O.D. Opt. 1 1/8" [28.58 mm] O.D. Std.*				
25' [7.62]	Optional	1.00	1.00	1.00		1.00	1.00	1.00	1.00
	Standard	1.00	1.00	1.00		1.00	1.00	1.00	1.00
	Optional	N/A	N/A	1.00		N/A	N/A	N/A	N/A
50' [15.24]	Optional	.98	.98	.96		.98	.99	.99	.99
	Standard	.99	.99	.98		.99	.99	.99	.99
	Optional	N/A	N/A	.99		N/A	N/A	N/A	N/A
100' [30.48]	Optional	.95	.95	.94		.96	.96	.96	.97
	Standard	.96	.96	.96		.97	.98	.98	.98
	Optional	N/A	N/A	.97		N/A	N/A	N/A	N/A
150' [45.72]	Optional	.92	.92	.91		.94	.94	.95	.94
	Standard	.93	.94	.93		.95	.96	.96	.97
	Optional	N/A	N/A	.95		N/A	N/A	N/A	N/A

NOTES: *Standard line size
Using suction line larger than shown in chart will result in poor oil return and is not recommended.

[] Designates Metric Conversions

BEFORE PURCHASING THIS APPLIANCE, READ IMPORTANT ENERGY COST AND EFFICIENCY INFORMATION AVAILABLE FROM YOUR RETAILER.

GENERAL TERMS OF LIMITED WARRANTY

Rheem will furnish a replacement for any part of this product which fails in normal use and service within the applicable period stated, in accordance with the terms of the limited warranty.

For Complete Details of the Limited Warranty, Including Applicable Terms and Conditions, See Your Local Installer or Contact the Manufacturer for a Copy.

CompressorTen (10) Years

*Any Other PartFive (5) Years

***This five year limited warranty is applicable only to single-phase products installed in residential applications on or after January 1, 2001.**

RAPL- JEZ Conditional Replacement Warranty: Rheem will provide a replacement model (if an exact replacement is not available, an equivalent product will be provided) to the original purchaser if the compressor fails within 5 years (providing the unit is installed with a new Rheem *Prestige Series*TM Air Handler OR Rheem Indoor Coil with a Rheem *Prestige Series*TM Gas Furnace, and is properly matched as specified by Rheem and/or listed in the Air Conditioning Institute (ARI) published rating, and if additional conditions are satisfied. See product warranty card for additional information.

NOTES

NOTES

Before proceeding with installation, refer to installation instructions packaged with each model, as well as complying with all Federal, State, Provincial, and Local codes, regulations, and practices.

**Rheem Heating,
Cooling and
Water Heating**

P.O. Box 17010, Fort Smith, AR 72917



"In keeping with its policy of continuous progress and product improvement, Rheem reserves the right to make changes without notice."