

Service Instructions

for use by heating contractor

VIESSMANN.

Vitodens 222-F, B2TA Series

Models 19 and 35

Floor mounted, gas-fired condensing storage combi boiler

For operation with natural gas and liquid propane gas

Heating input: 12 to 125 MBH

3.5 to 37 kW



VITODENS® 222-F



Product may not be exactly as shown

IMPORTANT

Read and save these instructions for future reference.

Safety, Installation and Warranty Requirements

Please ensure that these instructions are read and understood before commencing installation. Failure to comply with the instructions listed below and details printed in this manual can cause product/property damage, severe personal injury, and/or loss of life. Ensure all requirements below are understood and fulfilled (including detailed information found in manual subsections).

■ **Product documentation**

Read all applicable documentation before commencing installation. Store documentation near boiler in a readily accessible location for reference in the future by service personnel.

► *For a listing of applicable literature, please see section entitled "Important Regulatory and Installation Requirements".*



■ **Warranty**

Information contained in this and related product documentation must be read and followed. Failure to do so renders the warranty null and void.



■ **Licensed professional heating contractor**

The installation, adjustment, service and maintenance of this equipment must be performed by a licensed professional heating contractor.

► *Please see section entitled "Important Regulatory and Installation Requirements".*



■ **Contaminated air**

Air contaminated by chemicals can cause by-products in the combustion process, which are poisonous to inhabitants and destructive to Viessmann equipment.

► *For a listing of chemicals which cannot be stored in or near the boiler room, please see subsection entitled "Mechanical room" in the "Installation Instructions".*



■ **Advice to owner**

Once the installation work is complete, the heating contractor must familiarize the system operator/ultimate owner with all equipment, as well as safety precautions/requirements, shutdown procedure, and the need for professional service annually before the heating season begins.

■ **Carbon monoxide**

Improper installation, adjustment, service and/or maintenance can cause flue products to flow into living space. Flue products contain poisonous carbon monoxide gas.

► *For information pertaining to the proper installation, adjustment, service and maintenance of this equipment to avoid formation of carbon monoxide, please see subsection entitled "Mechanical room" and "Venting requirements" in the "Venting System Installation Instructions".*



■ **Fresh air**

This equipment requires fresh air for safe operation and must be installed ensuring provisions for adequate combustion and ventilation air exist.

► *For information pertaining to the fresh air requirements of this product, please see subsection entitled "Mechanical room" in the "Installation Instructions".*

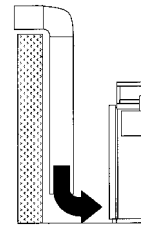

■ **Equipment venting**

Never operate boiler without an installed venting system. An improper venting system can cause carbon monoxide poisoning.

► *For information pertaining to venting and chimney requirements, please see section entitled "Venting Connection". All products of combustion must be safely vented to the outdoors.*



! WARNING

Installers must follow local regulations with respect to installation of carbon monoxide detectors. Follow the Viessmann maintenance schedule of the boiler contained in this manual.

! WARNING

This boiler requires fresh air for safe operation and must be installed with provisions for adequate combustion and ventilation air (in accordance with local codes and regulations of authorities having jurisdiction).

Do not operate this boiler in areas with contaminated combustion air. High levels of contaminants such as dust, lint or chemicals can be found at construction sites, home renovations, in garages, workshops, in dry cleaning/laundry facilities, near swimming pools and in manufacturing facilities.

Contaminated combustion air will damage the boiler and may lead to substantial property damage, severe personal injury and/or loss of life. Ensure boiler/burner is inspected and serviced by a qualified heating contractor at least once a year in accordance with the Service Instructions of the boiler.

Operating and Service Documentation

It is recommended that all product documentation such as parts lists, operating and service instructions be handed over to the system user for storage. Documentation is to be stored near boiler in a readily accessible location for reference by service personnel.

Safety, Installation and Warranty Requirements *(continued)*

Fiberglass wool and ceramic fiber materials



WARNING

Inhaling of fiberglass wool and/or ceramic fiber materials is a possible cancer hazard. These materials can also cause respiratory, skin and eye irritation.

The state of California has listed the airborne fibers of these materials as a possible cancer hazard through inhalation. When handling these materials, special care must be applied.

Suppliers of ceramic fiber products recommend the following first aid measures:

- *Respiratory tract (nose and throat) irritation:*
If respiratory tract irritation develops, move the person to a dust free location.
- *Eye irritation:* If eyes become irritated, flush immediately with large amounts of lukewarm water for at least 15 minutes. Eyelids should be held away from the eyeball to ensure thorough rinsing. Do not rub eyes.
- *Skin irritation:* If skin becomes irritated, remove soiled clothing. Do not rub or scratch exposed skin. Wash area of contact thoroughly with soap and water. Using a skin cream or lotion after washing may be helpful.
- *Gastrointestinal irritation:* If gastrointestinal tract irritation develops, move the person to a dust free environment.

Suppliers of fiberglass wool products recommend the following precautions be taken when handling these materials:

- Avoid breathing fiberglass dust and contact with skin and eyes.
- Use NIOSH approved dust/mist respirator.
- Wear long-sleeved, loose fitting clothing, gloves and eye protection.
- Wash work clothes separately from other clothing. Rinse washer thoroughly.
- Operations such as sawing, blowing, tear-out and spraying may generate airborne fiber concentration requiring additional protection.

First aid measures

- If eye contact occurs, flush eyes with water to remove dust. If symptoms persist, seek medical attention.
- If skin contact occurs, wash affected areas gently with soap and warm water after handling.



WARNING

Appliance materials of construction, products of combustion and the fuel contain alumina, silica, heavy metals, carbon monoxide, nitrogen oxides, aldehydes and/or other toxic or harmful substances which can cause serious injury or loss of life and which are known to the State of California to cause cancer, birth defects and other reproductive harm. Always use proper safety clothing, respirators and equipment when servicing or working nearby the appliance.

About these Installation Instructions



Take note of all symbols and notations intended to draw attention to potential hazards or important product information. These include "WARNING", "CAUTION", and "IMPORTANT". See below.



WARNING

Indicates an imminently hazardous situation which, if not avoided, could result in loss of life, serious injury or substantial product/property damage.

- ▶ *Warnings draw your attention to the presence of potential hazards or important product information.*



CAUTION

Indicates an imminently hazardous situation which, if not avoided, may result in minor injury or product/property damage.

- ▶ *Cautions draw your attention to the presence of potential hazards or important product information.*

IMPORTANT

- ▶ *Helpful hints for installation, operation or maintenance which pertain to the product.*

- ▶ *This symbol indicates that additional, pertinent information is to be found.*

- ▶ *This symbol indicates that other instructions must be referenced.*



	Page
Safety	
Safety, Installation and Warranty Requirements	2
Product documentation.....	2
Warranty.....	2
Licensed professional heating contractor.....	2
Advice to owner.....	2
Operating and Service Documentation.....	2
Carbon monoxide.....	2
Fresh air.....	2
Equipment venting.....	2
Fiberglass wool and ceramic fiber materials.....	3
First aid measures.....	3
About the Installation Instructions	3
General Information	
Necessary Tools	6
Important Regulatory and Installation Requirements	6
Codes.....	6
Technical literature.....	6
Initial start-up.....	6
Working on the equipment.....	6
Instructing the system user.....	6
Applicability	8
Product Information	8
Mechanical Room	9
Start-up	
Overview	10
Removing the Front Panels	11
Accessing the User Interface Programming Unit	11
Select Language	12
Set Time and Date	12
Filling Siphon With Water	12
Filling the Heating System	13
Bleed (Vent) Air from Boiler Heat Exchanger	14
Bleed (Vent) Air from Heating System	14
Check Power Supply Connection	15
Designating Heating Circuits	15
Select Gas Type	15
Convert Fuel Type to Liquid Propane Gas	16
Setting Altitude Parameters	16
Checking the Static and Supply Pressure	17
Sequence of Operation and Potential Faults During	
Each Start-up Cycles	18
Set Maximum Output	19
Check All Primary and Secondary Circuit	
Connections for Leaks	19
Service	
Perform Combustion Analysis	19
Checking the Balanced Flue System Tightness	
(Annular Gap Check)	20
Remove Burner Assembly	20
Checking the Burner Gasket and Burner Gauze	
Assembly	21
Check and Adjust Ignition and Ionization Electrodes	21
Cleaning the Heat Exchanger and Fitting the Burner	22

	Page
Service <i>(continued)</i>	
Checking the Condensate Drain and Cleaning the Siphon.....	23
Check Neutralization Unit.(if applicable).....	23
Draining the Boiler on the DHW Side.....	24
Cleaning the DHW Storage Tank.....	24
Checking the Diaphragm Expansion Vessel and System Pressure.....	25
Check Functioning of Safety Valves.....	25
Check Electrical Connections.....	26
Check Gas Pipes and Fittings for Leaks.....	26
Clock Natural Gas Meter.....	27
Check CO ₂ Setting.....	28
Outdoor Reset Programming Unit	
Start-up and Shutdown.....	29
Menu.....	29
Combustion Management System.....	31
Functional Description.....	32
Installation Examples.....	33
System version 1.....	33
System version 2.....	34
System version 3.....	35
System version 4.....	36
System version 5.....	37
Heating Curve Adjustment.....	38
Connecting the Boiler Control to a LON System.....	40
Coding 1	
General.....	42
Boiler.....	44
DHW.....	44
Heating Circuit 1, 2 and 3.....	45
Coding 2	
General.....	49
Boiler.....	56
DHW.....	57
Heating Circuit 1, 2 and 3.....	59
Calling up the Service Level.....	65
Diagnosis and Service Scans	
Diagnosis.....	66
Troubleshooting	
Checking Outputs (relay tests).....	68
Fault Codes.....	69
Corrective Action.....	77
External Extensions AM1.....	85
Function Description	
Internal Extensions EA1.....	86
Internal Extensions (Accessories).....	87
Control Functions.....	88
Wiring Diagram.....	90
Burner Program Sequence of Operation.....	92
Parts	
Parts Lists.....	93
Installation fittings.....	101
Additional Information	
Technical Data.....	102
Maintenance Record.....	104
Lighting and Operating Instructions.....	105

Necessary Tools

Testing/analysis equipment (Use only calibrated equipment)

- Multimeter to measure 0 - 230V, 0 - 12A AC and 0-100 mA DC
- Flue gas analyzer to measure % CO₂ or O₂ (i.e. Bacharach fluid samplers or suitable electronic analyzer)
- Manometer to measure gas pressure 0 to 11 "w.c. (accurately) and up to 28 "w.c. gas pressure (or a non-electric Magnehelic® manometer may also be utilized)
- Stack thermometer 0 to 500° F (0 to 260° C)
- Bacharach calculator or suitable tables to calculate efficiency
- Carbon monoxide measuring equipment 0 to 400 ppm

Cleaning supplies

- Plastic hand brush
- Rags

Special items

- Approved leak detection fluid for natural gas and liquid propane gas
- Pipe joint sealant

Important Regulatory and Installation Requirements

Codes

The installation of this unit shall be in accordance with local codes or, in the absence of local codes, use CAN/CSA-B149.1 or .2 Installation Codes for Gas Burning Appliances for Canada. For U.S. installations use the National Fuel Gas Code ANSI Z223.1. Always use latest editions of codes.

In Canada all electrical wiring is to be done in accordance with the latest edition of CSA C22.1 Part 1 and/or local codes. In the U.S. use the National Electrical Code ANSI/NFPA 70. The heating contractor must also comply with both the Standard for Controls and Safety Devices for Automatically Fired Boilers, ANSI/ASME CSD-1, and the Installation Code for Hydronic Heating Systems, CSA B214-01, where required by the authority having jurisdiction.

Technical literature

Literature for the Vitodens boiler:

- Technical Data Manual
- Installation Instructions
- Service Instructions
- Operating Instructions and User's Information Manual
- Instructions of other Viessmann products utilized and installed
- Installation codes mentioned in this manual

Leave all literature at the installation site and advise the system operator/ultimate owner where the literature can be found. Contact Viessmann for additional copies.

This product comes with several safety instruction labels attached. Do not remove! Contact Viessmann immediately if replacement labels are required.

Initial start-up

Initial start-up must be performed by a qualified heating contractor. Proper completion of the Maintenance Record by the heating contractor is also required. The Maintenance Record is located in the Service Instructions.

Working on the equipment

The installation, adjustment, service, and maintenance of this boiler must be done by a licensed professional heating contractor who is qualified and experienced in the installation, service, and maintenance of hot water boilers. There are no user serviceable parts on the boiler, burners, or control.

Please carefully read this manual prior to attempting start-up, maintenance or service. Any warranty is null and void if these instructions are not followed.

For information regarding other Viessmann System Technology componentry, please reference documentation of the respective product.

We offer frequent installation and service seminars to familiarize our partners with our products. Please inquire.

Ensure main power supply to equipment, the heating system, and all external controls has been deactivated. Close main gas supply valve. Take precautions in all instances to avoid accidental activation of power during service work.

The completeness and functionality of field supplied electrical controls and components must be verified by the heating contractor. These include low water cut-offs, flow switches (if used), staging controls, pumps, motorized valves, air vents, thermostats, etc.

Instructing the system user

The installer of the system is responsible to ensure the system operator/ultimate owner is made familiar with the system functioning, its activation, and its shut-down.

The following topics must be covered:

- Proper system operation sequence.
- Explain the equipment.
- Demonstrate an emergency shut-down, what to do and what not.
- Explain that there is no substitute for proper maintenance to help ensure safe operation.

Important Regulatory and Installation Requirements *(continued)*

For installations on the Commonwealth of Massachusetts, the following modifications to NFPA-54 chapter 10 apply:
Excerpt from 248 CMR 5-08:

- 2(a) For all side-wall horizontally vented gas fueled equipment installed in every dwelling, building or structure used in whole or in part for residential purposes, including those owned or operated by the Commonwealth and where the side-wall exhaust vent termination is less than (7) feet above finished grade in the area of the venting, including but not limited to decks and porches, the following requirements shall be satisfied:
1. **INSTALLATION OF CARBON MONOXIDE DETECTORS.** At the time of installation of the side-wall horizontal vented gas fueled equipment, the installing plumber or gasfitter shall observe that a hard wired carbon monoxide detector with an alarm and battery back-up is installed on the floor level where the gas equipment is to be installed. In addition, the installing plumber or gasfitter shall observe that a battery operated or hard wired carbon monoxide detector with an alarm is installed on each additional level of the dwelling, building or structure served by the side-wall horizontal vented gas fueled equipment. It shall be the responsibility of the property owner to secure the services of qualified licensed professional for the installation of hard-wired carbon monoxide detectors.
 - a. In the event that the side-wall horizontally vented gas fueled equipment is installed in a crawl space or an attic, the hard-wired carbon monoxide detector with alarm and battery back-up may be installed on the next adjacent floor level.
 - b. In the event that the requirements of this subdivision can not be met at the time of completion of installation, the owner shall have a period of thirty (30) days to comply with the above requirements; provided, however, that during said thirty (30) day period, a battery operated carbon monoxide detector with an alarm shall be installed.
 2. **APPROVED CARBON MONOXIDE DETECTORS.** Each carbon monoxide detector as required in accordance with the above provisions shall comply with NFPA 720 and be ANSI/UL 2034 listed and IAS certified.
 3. **SIGNAGE.** A metal or plastic identification plate shall be permanently mounted to the exterior of the building at a minimum height of eight (8) feet above grade directly in line with the exhaust vent terminal for the horizontally vented gas fueled heating appliance or equipment. The sign shall read, in print size no less than one-half (1/2) inch in size, "GAS VENT DIRECTLY BELOW. KEEP CLEAR OF ALL OBSTRUCTIONS".
 4. **INSPECTION.** The state or local gas inspector of the side-wall horizontally vented gas fueled equipment shall not approve the installation unless, upon inspection, the inspector observes carbon monoxide detectors and signage installed in accordance with the provisions of 248 CMR 5.08(2)(a) 1 through 4.
- (b) **EXEMPTIONS:** The following equipment is exempt from 248 CMR 5.08(2)(a) 1 through 4:
1. The equipment listed in Chapter 10 entitled "Equipment Not Required To Be Vented" in the most current edition of NFPA 54 as adopted by the Board; and
 2. Product Approved side-wall horizontally vented gas fueled equipment installed in a room or structure separate from the dwelling, building or structure used in whole or in part for residential purposes.

CSD-1 Field Testing of High Limit Switches for Vitodens boilers – where required by law.

VISSMANN IS NOT RESPONSIBLE FOR ANY DAMAGES THAT THE FOLLOWING TEST PROCEDURE MAY RESULT IN BY OVERHEATING THE SYSTEM.

The Vitodens 100/200 boilers are equipped with flow switches that when activated disable or enable the burner to operate.

The fixed high limit, when tripped, produces a fault that will require manual reset of the boiler control.

Fixed High Limit fault simulation #1:

- Close the boiler valve and jumper across the flow switch.
- Run the boiler at high fire and it will shut down by the coding card (in B2TA models, set coding address 06 to maximum) but should continue to stack the boiler temp until the fixed high limit is tripped.
- Once the fixed high limit is tripped, slowly open the boiler valve to safely cool the boiler down.

Fixed High Limit fault simulation #2:

- Throttle the boiler valve to a point where the burner will run with as little flow as possible.
- Run the boiler to high fire via relays test.
- When the burner shuts down on the electronic limit, close the ball valve to stop the flow.
- The boiler temp should continue a steady increase to trip the fixed high limit.
- Once the fixed high limit is tripped, slowly open the boiler valve to safely cool the boiler down.

Fixed High Limit fault simulation #3:

- Remove one of the wires connected to limit switch, this will produce a fault in the boilers control that requires manual reset.

Applicability

CAUTION

The boiler serial number must be provided when ordering replacement parts. Some replacement parts are not reverse compatible with previous versions of the Vitodens 222-F B2TA boiler.

IMPORTANT

When ordering replacement parts, provide either the 16-digit boiler serial number (on the bar code label) or the 12-digit ASME/NB serial number, located as shown underneath boiler front enclosure panel. Refer to page 11 for instructions on how to remove front enclosure panel.

Model No. B2TA 19
Serial No. 7510826 □□□□□□□□

Model No. B2TA 35
Serial No. 7510827 □□□□□□□□

- (A) Stainless steel Inox-Radial heat exchanger for high operational reliability, a long service life and high heating output in the smallest spaces
- (B) Modulating MatriX cylinder gas burner for extremely clean combustion and quiet operation.
- (C) Integral diaphragm expansion vessel
- (D) Graphical user interface
- (E) Integral, 3-speed high efficiency circulation pump
- (F) Stainless steel DHW primary storage tank.

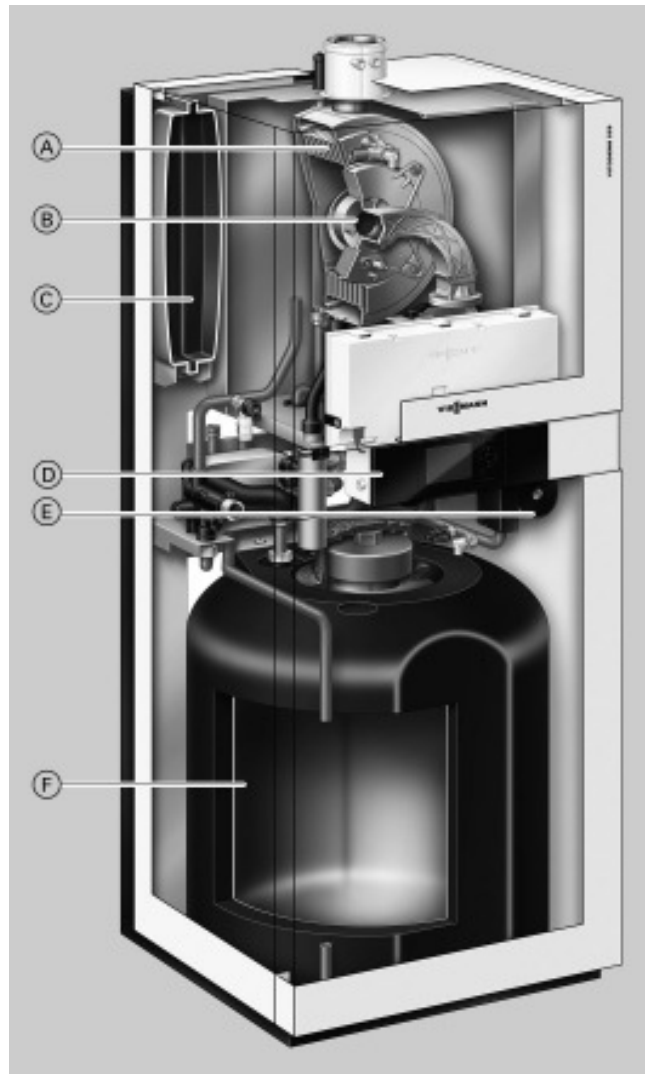

Product Information

Natural gas and liquid propane gas-fired condensing heating boiler for weather-responsive operation in closed loop, forced circulation hot water heating systems for space heating and domestic hot water (DHW) production.

The Vitodens 222-F, B2TA series boiler comes factory set for operation with natural gas. For a fuel conversion to liquid propane gas no conversion kit is required (see page 16).

The integral primary storage tank 26.5 USG (100 L) capacity offers the convenience of a separate DHW tank with approximately twice that volume.

Boiler model must be selected based on an accurate heat loss calculation of the building. Ensure boiler model is compatible with connected radiation.

Vitodens 222-F, B2TA series boilers are factory-tested and calibrated. Further gas valve adjustments are not typically required during field start-up.



Follow the Vitodens Venting System Installation Instructions to vent this boiler.

Mechanical Room

During the early stages of designing a new home, we recommend that proper consideration be given to constructing a separate mechanical room dedicated to the gas- or oil-fired heating equipment and domestic hot water storage tank(s).

The boiler must be located in a heated indoor area, near a floor drain, and as close as possible to a wall. Whenever possible, install the boiler near an outside wall so that it is easy to duct the venting system to the boiler.

Locate the boiler on a wall capable of supporting the weight of the boiler filled with water (see section entitled "Technical Data" on page 101 for information required for total boiler weight calculation). Ensure that the boiler location does not interfere with the proper circulation of combustion and ventilation air of other fuel burning equipment within the mechanical room (if applicable).

The maximum room temperature of the mechanical room where the boiler is located must not exceed 104° F (40° C).

Installation area conditions



WARNING

Incorrect ambient conditions can lead to damage to the heating system and put safe operation at risk.

- Ensure ambient temperatures are higher than 32° F (0° C) and lower than 104° F (40° C).
- Prevent the air from becoming contaminated by halogenated hydrocarbons (e.g. as contained in paint solvents or cleaning fluids) and excessive dust (e.g. through grinding or polishing work). Combustion air for the heating process, and ventilation of the boiler room must be free of corrosive contaminants. To that end, any boiler must be installed in an area that has no chemical exposure. The list to the right indicates the main, currently known sources.
- Avoid continuously high levels of humidity (e.g. through frequent drying of laundry).
- Never close existing ventilation openings.



WARNING

If you notice fire coming from the appliance, call the fire department immediately! Do not attempt to extinguish the fire unless qualified to do so.

IMPORTANT

The service life of the boiler's exposed metallic surfaces, such as the casing and fan housing, is directly influenced by proximity to damp and salty marine environments. In such areas, higher concentration levels of chlorides from sea spray, coupled with relative humidity, can lead to degradation of the exposed metallic surfaces mentioned above. Therefore, it is imperative that boilers installed in such environments not be installed using direct vent systems which draw outdoor air for combustion. Such boilers must be installed using room air dependent vent systems; i.e. using room air for combustion. The indoor air will have a much lower relative humidity and, hence, potential corrosion will be minimized.

Sources of combustion and ventilation air contaminants

Areas likely to contain contaminants:

- New building construction
- Swimming pools
- Remodelling areas, hobby rooms
- Garages with workshops
- Furniture refinishing areas
- Dry cleaning/laundry areas and establishments
- Auto body shops
- Refrigeration repair shops
- Metal fabrication plants
- Plastic manufacturing plants
- Photo processing plants
- Beauty salons

Products containing contaminants:

- Chlorine-type bleaches, detergents and cleaning solvents found in household laundry rooms
- Paint and varnish removers
- Hydrochloric acid, muriatic acid
- Chlorine-based swimming pool chemicals
- Spray cans containing chlorofluorocarbons
- Chlorinated waxes and cleaners
- Cements and glues
- Refrigerant leaks
- Calcium chloride used for thawing
- Sodium chloride used for water softening salt
- Permanent wave solutions
- Adhesives used to fasten building products and other similar items
- Antistatic fabric softeners used in clothes dryers

Boiler operation in marine environments (damp, salty coastal areas)



WARNING

Fire causes a risk of burns and explosion!

- Shut down the boiler
- Close fuel shut-off valves
- Use a tested fire extinguisher, class ABC.

Overview

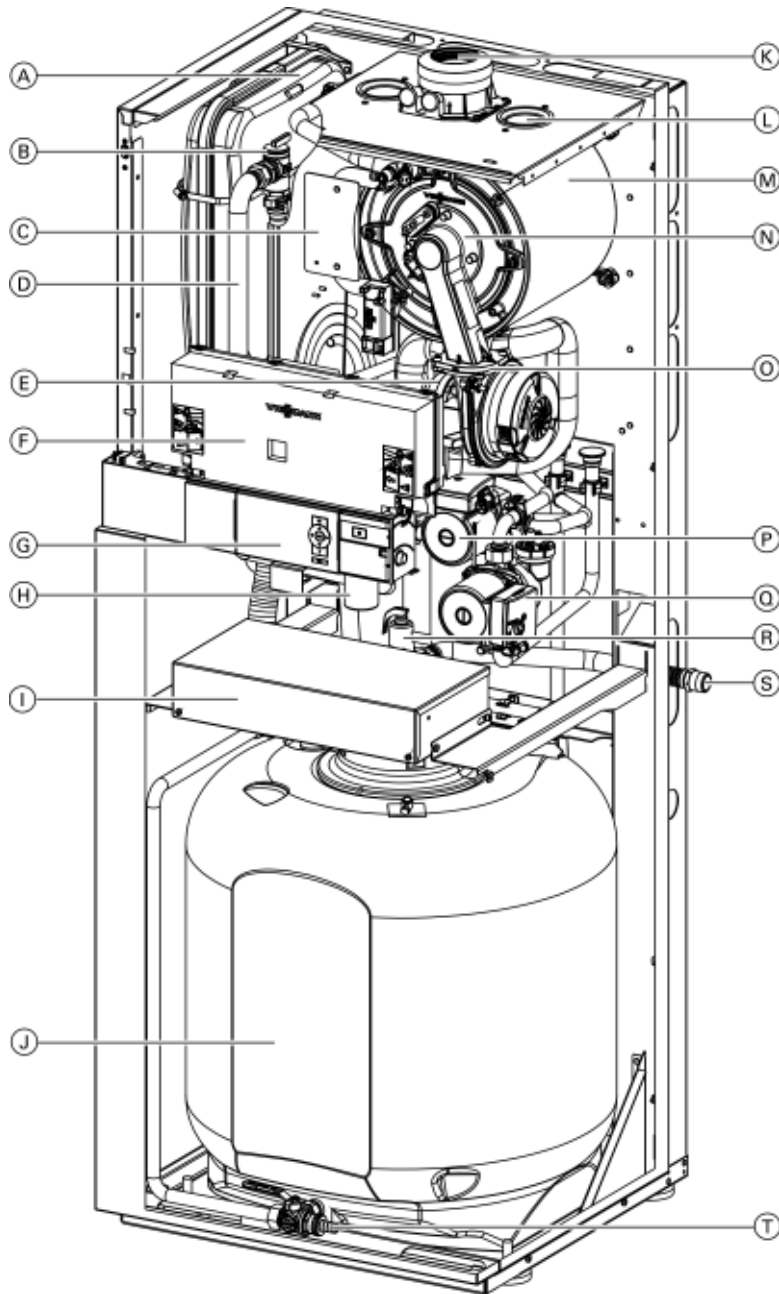

Legend

- | | |
|--|---------------------------------|
| Ⓐ Expansion tank | Ⓚ Flue adaptor |
| Ⓑ Boiler PRV | Ⓛ Optional air intake |
| Ⓒ ASME rating plate | Ⓜ ASME certified heat exchanger |
| Ⓓ Drain pipe for boiler PRV | Ⓝ Matrix burner |
| Ⓔ Mixer damper | Ⓞ Air Venturi |
| Ⓕ Boiler control | Ⓟ DHW pump |
| Ⓖ HO1B Control unit (graphical user interface) | Ⓠ 3 speed boiler pump |
| Ⓗ Condensate siphon | Ⓡ TPR valve |
| Ⓘ External accessories connection box | Ⓢ Drain pipe for TPR valve |
| Ⓝ DHW storage tank | Ⓣ DHW drain valve |

Removing the Front Panels

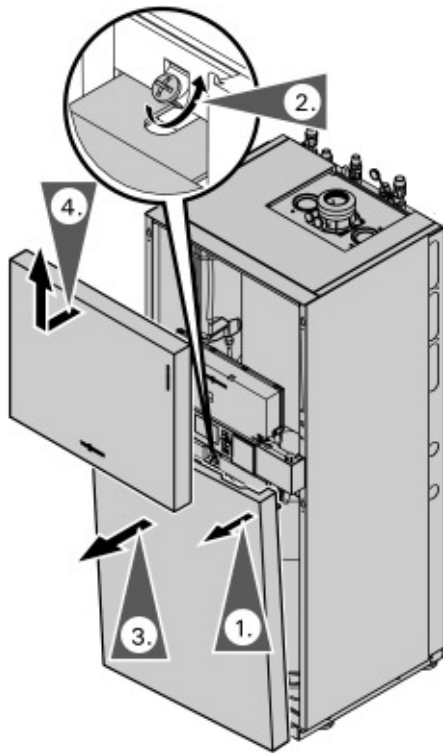

Some of the following service steps require the removal of the front enclosure panel. To avoid personal injury and/or product damage of any kind please follow the instructions below carefully when removing the front enclosure panel.

IMPORTANT

Close the main gas supply line.

1. Tilt and remove the lower front panel.
2. Remove the retaining screw and set aside.
3. Remove the lower front panel.
4. Remove the front upper panel.

Accessing the User Interface Programming Unit

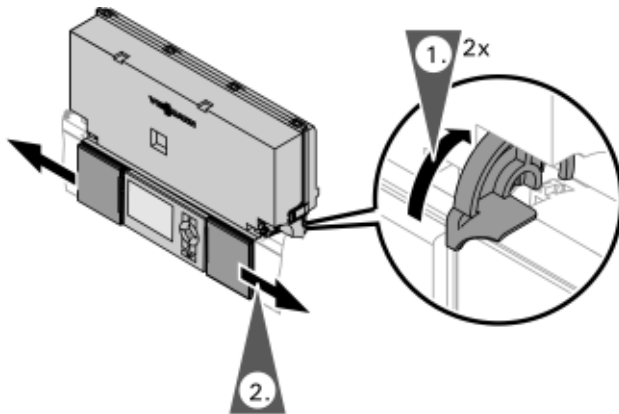

1. Turn up both locks to unlock the user interface programming unit covers.
2. Slide open the user interface programming unit covers.
3. Turn on the boiler by pressing the ON/OFF switch.

Select Language



At the commissioning stage, the display is in German.

1. "Sprache" (Language) Deutsch DE (German)
2. Select the required language with ▲/▼
3. Accept by pressing OK.

To change the language

Extended menu:

1. ≡
2. "Settings"
3. "Language"
4. Select the required language with ▲/▼
5. Accept by pressing OK.

Set Time and Date

Setting the time and date

During commissioning.

1. Using the ▲/▼ set the current time
2. Accept by pressing OK, this will move to date
3. Using the ▲/▼ set the current date
4. Press OK to complete

To change the time/date after prolonged time out of use.

Extended menu:

1. ≡
2. "Settings"
3. "Time / Date"
4. Set current time and date (as shown above).

Filling Siphon With Water

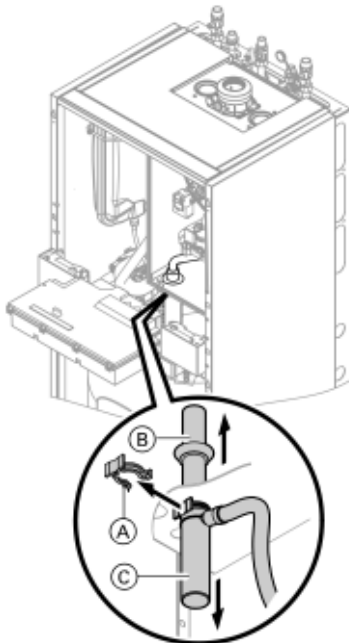

1. Pivot control unit forward.
2. Pull retaining clip (A) off.
3. Pull filler pipe (B) upwards.
4. Pull off trap (C) downwards.
5. Fill siphon with water and reassemble.
6. Check that the condensate pipe is connected correctly to the siphon and heat exchanger.
7. Refit cover panel.
8. Secure control unit back in operating position.

Filling the Heating System

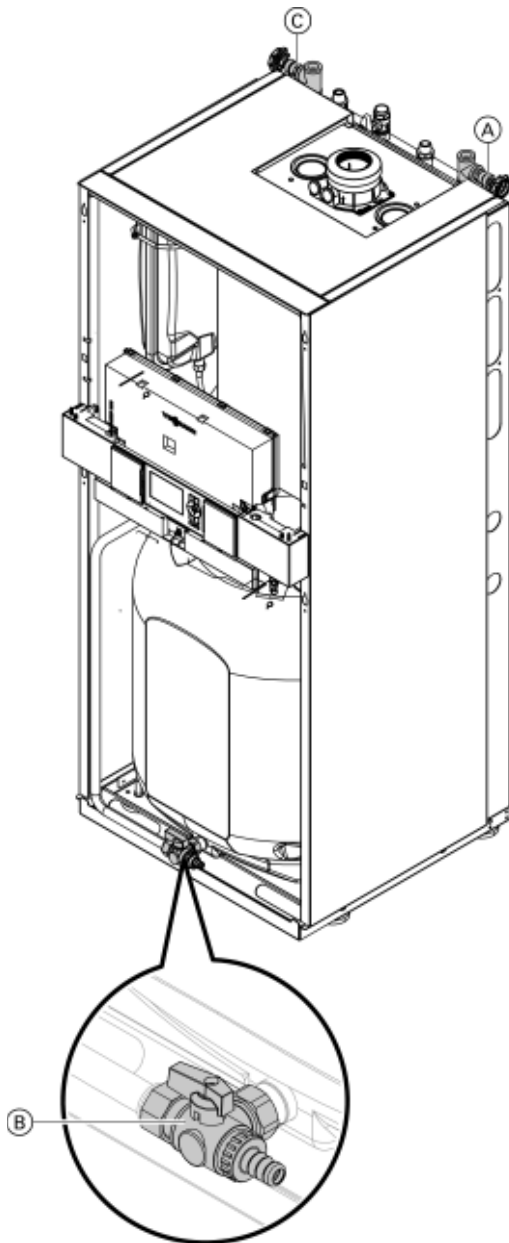

CAUTION

Unsuitable fill water increases the level of deposits and corrosion, and may lead to damage to the equipment.

- Thoroughly flush the entire heating system prior to filling with water.
- Only use water of potable quality.
- The water will have to be softened if it is harder than 17.5 grains / 300 ppm total dissolved solids.
- Inhibitors or antifreeze additives suitable for heating systems may be added manually.

1. Check the pre-charge pressure of the diaphragm expansion vessel.
2. Close the gas shut-off valve.
3. Fill heating system via boiler drain & fill valve (A) in the heating return (at the connection set on the side or above the boiler). Minimum system pressure > 14 psi.

Note: If the control unit has not been switched on prior to filling the system, then the servomotor of the diverter valve will still be in its central position, and the system will be completely filled.

Note: Lever on valve (B) must be in the "left" position.

4. If the control unit had already been switched on before filling began: Switch control unit ON and activate filling program (see next steps).
5. Close boiler drain (C) & open fill valve (A).



Activating filling (bleeding) program:

1. Press OK and simultaneously for approximately 4 seconds.
2. "Service functions"
3. "Filling"
4. Ending filling function: Press OK or .

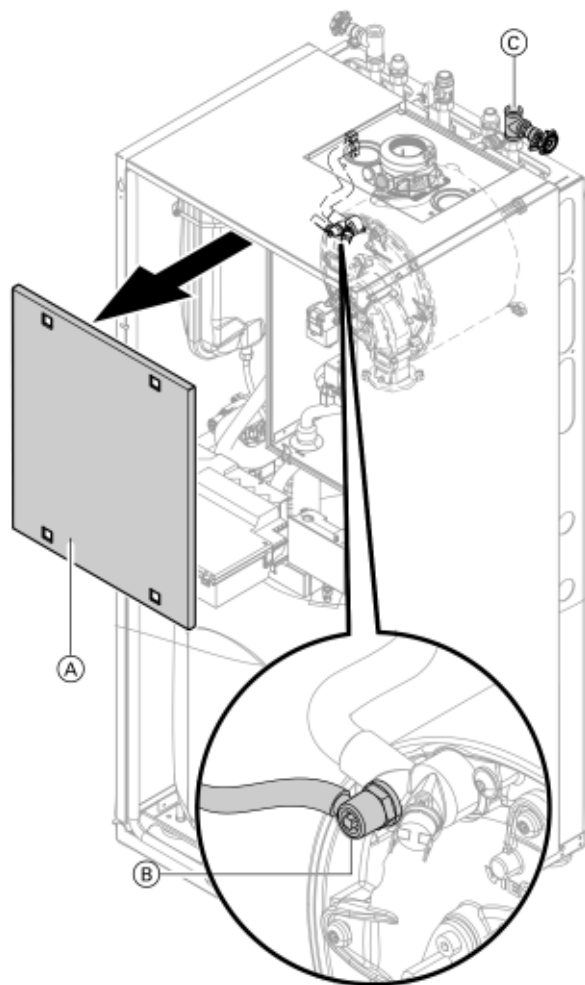

Bleed (Vent) Air from Boiler Heat Exchanger



Note: To prevent equipment damage, do not bleed the boiler heat exchanger via the pressure relief valve on the heating water side.

1. Close the shut-off valves (field supplied) on the heating water side.
2. Remove cover panel (A).
3. Connect the drain hose on valve (B) with a drain.
Note: The drain hose is located loosely inside the heat exchanger compartment.
4. Open air vent valve (B) using a key and fill via the sediment faucet (C) in the heating return and vent using mains pressure (flush) until no more air noise can be heard.
Note: The key is supplied with the installation fittings.
5. Close valve (B) and fill valve (C) in the heating return, and open the shut-off valves on the heating water side.
6. Activating the venting program:
Service menu
- Press OK and  simultaneously for approximately 4 seconds.
- "Service functions"
- "Venting" (bleeding)
Venting function is enabled.
Ending venting function:
- Press OK or .

Bleed (Vent) Air from Heating System

1. Close the gas shut-off valve and switch the control unit ON.
2. Activate venting program (see next steps).
- Press OK and  simultaneously for approximately 4 seconds.
- "Service functions"
- "Venting"
Venting function is enabled.
Ending venting function:
- Press OK or .
3. Check the system pressure.

Check Power Supply Connection

An external accessories connection box is integrated within the Vitodens 222-F, B2TA boiler, which requires a 120V AC power supply from a wall receptacle (12A fuse protected).

Refer to the Installation Instructions shipped with the boiler.

Voltage range

The voltage at connector **40** of the boiler control must be 120V (see wiring diagram).

Neutral conductor

The electrical power supply must have a neutral conductor.

IMPORTANT

In Canada all electrical wiring is to be done in accordance with the latest edition of CSA C22.1 Part 1 and/or local codes. In the U.S. use the National Electrical Code ANSI/NFPA 70. The heating contractor must also comply with both the Standard for Controls and Safety Devices for Automatically Fired Boilers, ANSI, ASME CSD-1.

Note: The outer conductor "L" and the neutral conductor "N" must not be interchanged.

See wiring diagram on page 90 in section entitled "Additional Information".

Designating Heating Circuits

In the factory set condition, the heating circuits are designated "Heating circuit 1", "Heating circuit 2" and "Heating circuit 3" (if installed).

If the system user prefers, the heating circuits can be designated differently to suit the specific system.



Enter names for heating circuits see Operating instructions

Select Gas Type

Note: the Vitodens 222-F, B2TA boiler is factory set to operation with natural gas. See following subsection for conversion instructions to liquid propane gas.

1. Ensure that the fuel type listed on the boiler rating plate is the correct type for the installation being attempted.
2. Record fuel type in Maintenance Record on page 103.

The Vitodens 222-F boiler is for use with gases whose characteristics fall within the following ranges. Do not use any other types of gas.

		Natural gas	Liquid propane gas
Heating value (gross)	Btu/ft ³	970 to 1100	2466 to 2542
Specific gravity		0.57 to 0.70	1.522 to 1.574
Ultimate carbon dioxide (CO ₂)	%	11.7 to 12.2	13.73 to 13.82

Convert Fuel Type to Liquid Propane Gas

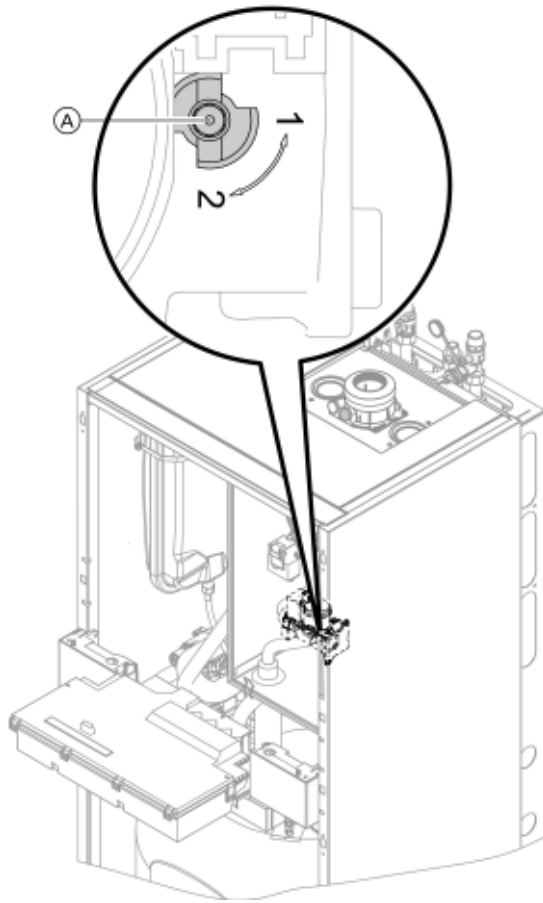

1. Set adjusting screw (A) at the gas valve to "2" (using a hex key, 2.5 mm).
Note: The Vitodens 222-F, B2TA boiler comes factory adjusted for operation with natural gas. Coding address "82" is set to "0" (operation with natural gas) in the factory default setting.
2. Switch ON/OFF switch (B) to ON.
Note: Slide the black control cover outwards to access the ON/OFF switch.
3. Select the gas type in coding address "82".
 - Call up coding level 2. (see page 49)
 - Call up "General".
 - In coding address "11" select value "9".
 - In coding address "82" select value "1" (operation with liquid propane gas).
 - Go back to coding address "11" and select any value (except "9").
 - Terminate coding level 2.
4. Open gas shut-off valve.
5. Apply LPG supplied fuel conversion labels.

Setting Altitude Parameters

In the factory default setting, the boiler is equipped to operate in altitudes of up to 5,000 ft. (1,500 m).

Altitude can be set using coding address 93: (in coding level 2 General).

- Coding 11:9 must be set in order to unlock coding 93:.
- 93:0 is reserved for altitudes up to 5000 ft. (1500 m).
- 93:6 must be set for altitudes from 5000 ft. (1500 m) to 10000 ft. (3000 m)
- Setting back to 93:0 turns off the high altitude function.

IMPORTANT

Do not set or use coding addresses 93:1 to 93:5.

- After setting coding address 93:, set coding address 11:0
- The program is automatically disabled after 20 minutes.

Checking the Static and Supply Pressure

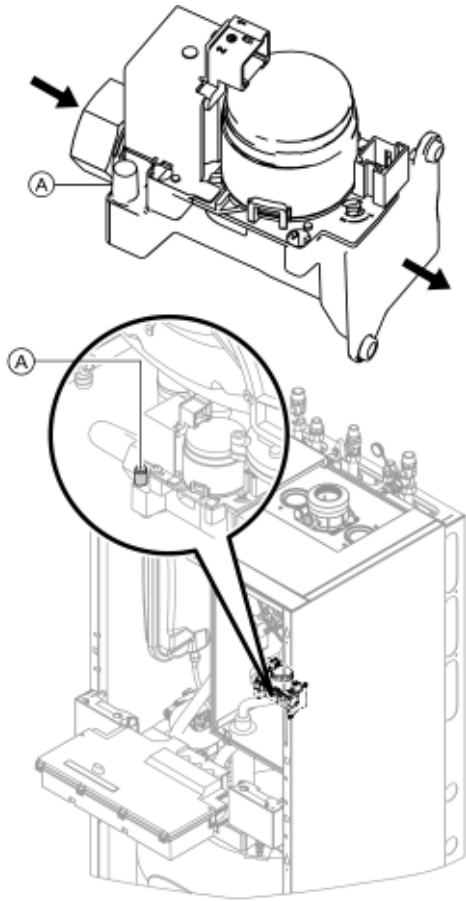

1. To measure static and/or running pressure remove boiler enclosure panel as indicated page 11 and 14 in these instructions.
2. Close gas shutoff valve.
3. Loosen screw at inlet gas pressure port (A) on the gas combination valve, do not remove completely. Connect manometer.
4. Open the gas shutoff valve.
5. Measure static pressure. Values must be:
14 "w.c. max. for NG
14 "w.c. max. for LPG
6. Enter measured value into Maintenance Record on page 103 in this manual.
7. Start up boiler, using the ON/OFF switch "ⓐ" on the boiler control.
8. Measure the running pressure, see chart.
9. Enter gas type into Maintenance Record on page 103 in this manual.
10. Switch off the ON/OFF switch "ⓐ" on the boiler control, close the gas shut-off valve, remove the manometer and re-tighten the screw at inlet gas pressure port (A).

Operation with LPG

Flush the LPG tank twice during commissioning or replacement. Purge the tank and gas supply line thoroughly after flushing.

Running supply pressure with		Corrective action
NG	LPG	
under 4 "w.c.	under 10 "w.c.	Do not start the boiler. Notify your gas supply utility or LPG supplier.
4 to 14 "w.c.	10 to 14 "w.c.	Start up boiler.
over 14 "w.c.	over 14 "w.c.	Do not attempt adjustment. Call local gas utility to decrease pressure or install up stream gas pressure regulator. Boiler valve must not be exposed to pressure over 14 "w.c.

IMPORTANT

The burner is automatically ignited and starts operation after a safety time has elapsed. During initial start-up, the unit may indicate a fault because of air in the gas supply pipe (especially for liquid propane gas). After approximately 5 seconds, press the "R" button to reset the burner. The ignition procedure is repeated. This boiler employs a direct spark ignition system.

WARNING

Ensure that there is no open flame in the room.

WARNING

CO build-up as a result of incorrect burner adjustment can have serious health implications. Carry out a CO test before and after work on gas appliances.

WARNING

Never purge a gas line into a combustion chamber. Never use matches, candles, flame, or other sources of ignition for purpose of checking leakage. Use a soap and water solution to check for leakage. A failure to follow this warning could result in fire, explosion, personal injury or death.

WARNING

Gas escaping from the test nipple leads to a risk of explosion. Check gas tightness at test nipple (A).

Sequence of Operation and Potential Faults During Each Start-up Cycle

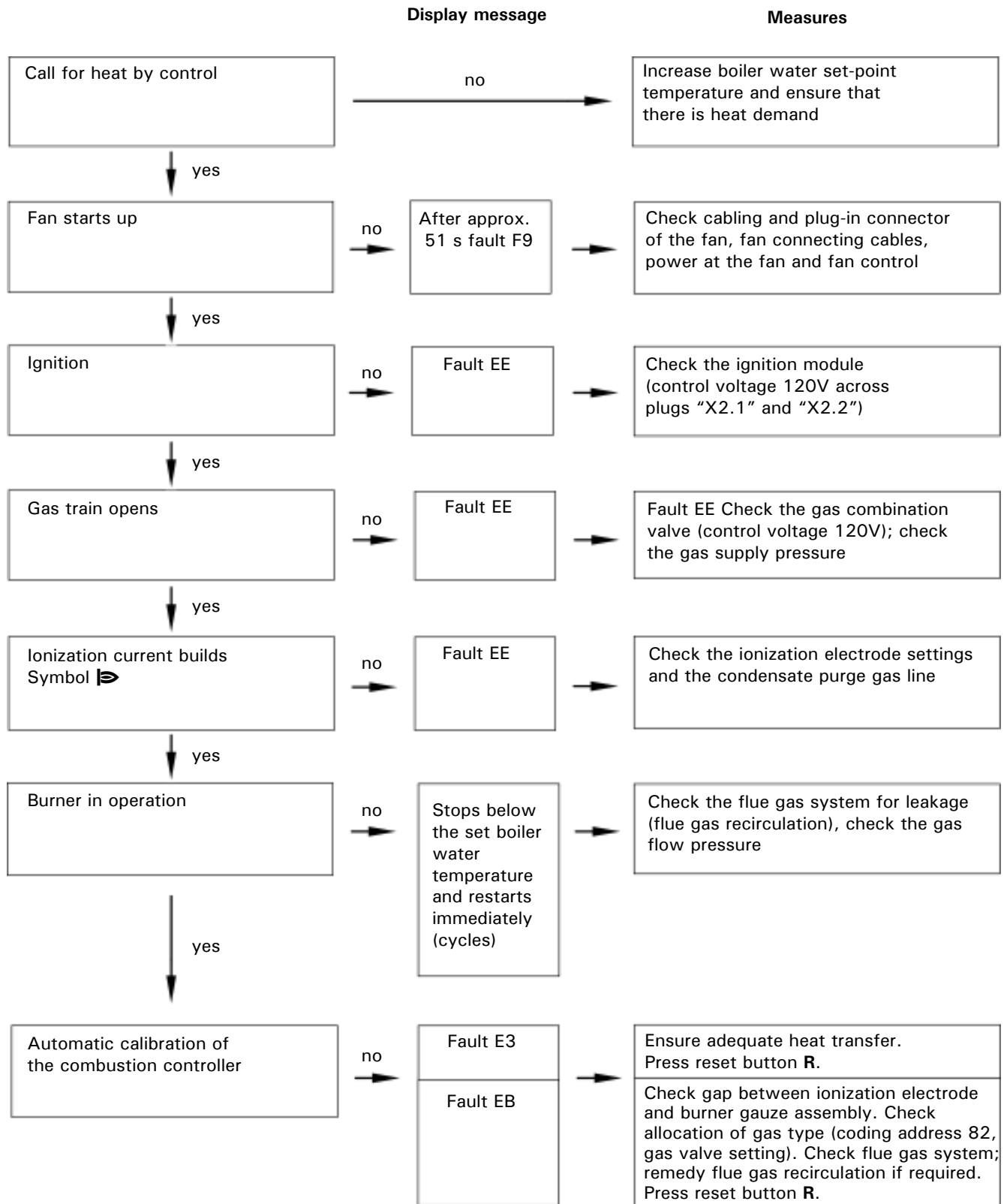

For further details regarding faults, see page 69.

Set Maximum Output

The maximum output for heating operation can be limited. The limit is set via the modulation range. The maximum adjustable heating input (or output) is limited upwards by the boiler coding card.

Note: The input for DHW production can be limited as well. To do so, change coding address "6F" in coding level 2.

1. Press OK and  simultaneously for approximately 4 seconds.
2. "Service functions"
3. "Maximum output"
4. "Change?" Select "Yes".
A value flashes on the display (e.g. "85"). In the factory setting, this value represents 100% of rated output.
5. Select required value.

Check All Primary and Secondary Circuit Connections for Leaks

Check heating system and domestic hot water connections. Ensure all connections are pressure tight. Correct any leaks found on fittings, pumps, valves, etc.

Perform Combustion Analysis

IMPORTANT

A CO measurement (see page 28) must be taken before and after working on gas appliances to eliminate risks to health and to guarantee the satisfactory condition of the system.

Record the measured combustion values in the sequence stated in the Maintenance Record on page 103 in this manual.

Checking the Balanced Flue System Tightness (Annular Gap Check)

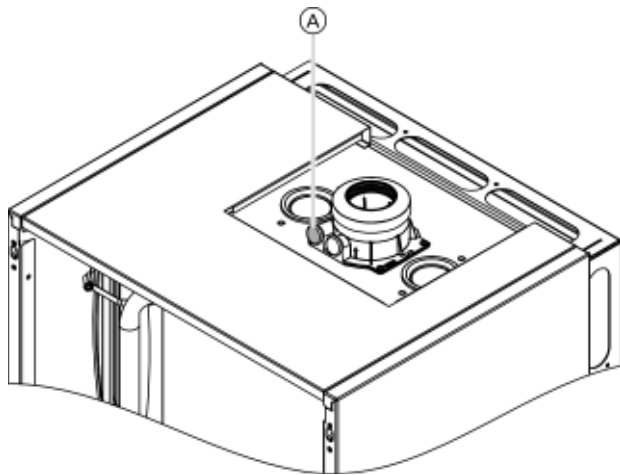

Ⓐ Combustion air measuring port

Viessmann strongly recommends that the heating contractor perform a simplified leak test during boiler start-up. For this purpose it is sufficient to measure the CO₂ concentration of the combustion air in the coaxial gap of the air intake pipe. The vent pipe is considered sufficiently leak-proof if a CO₂ concentration in the combustion air no higher than 0.2% or an O₂ concentration no lower than 20.6% is measured. If higher CO₂ values or lower O₂ values are measured, check venting system thoroughly.

Note: The vent pipe adaptor comes with two measurement ports, one for combustion air-intake measurement and one for flue gas measurement.

Remove Burner Assembly

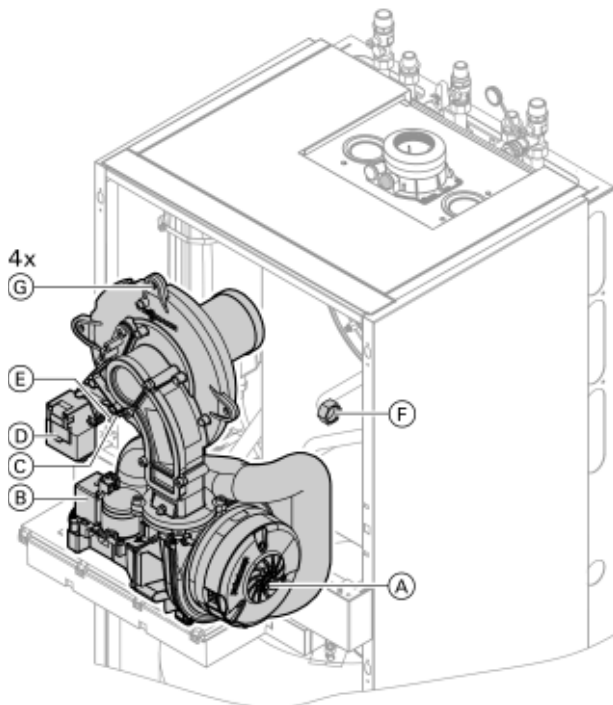

1. Switch OFF the main power supply and the ON/OFF switch ⓐ at the control unit.
2. Close the gas shut-off valve and safeguard against reopening.
3. Remove front upper panel, see page 11.
4. Flip down control console, see page 11.
5. Remove boiler inner cover.
6. Pull electrical cables from fan motor Ⓐ, gas valve Ⓑ, ionization electrode Ⓒ, ignition unit Ⓓ and ground wire Ⓔ.
7. Release gas supply pipe fitting Ⓕ.
8. Remove four torx screws Ⓖ.
9. Remove burner assembly.

CAUTION

To avoid damage to the burner, do not lay burner on its cylindrical burner tube or touch the burner tube mesh. Failure to heed this caution may cause damage to the burner tube, which may lead to improper operation.

Checking the Burner Gasket and Burner Gauze Assembly

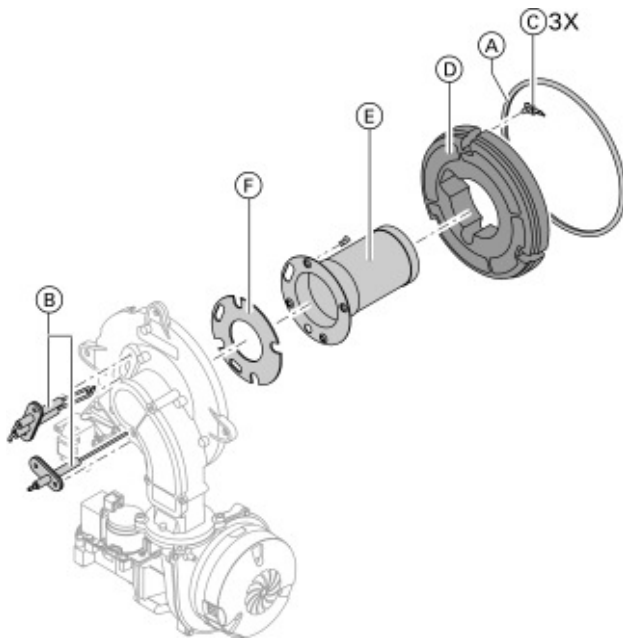

Check burner door gasket (A) and cylinder burner assembly (E) for damage; replace if required.

1. Remove electrode block and ionization electrode (B).
2. Undo three retaining clips (C) on thermal refractory ring (D) and then remove thermal refractory ring (D).
3. Undo four Torx screws and remove burner gauze assembly (E) with gasket (F).
4. Insert and secure a new burner gauze assembly (E) with a new gasket (F). Tighten to a torque of 31 lb.in. (3.5 Nm) using a calibrated torque wrench.
5. Reinstall refractory ring (A) and secure with retaining clip (C).
6. Reinstall electrode block and ionization electrode (B). Tighten to a torque of 40 lb.in. (4.5 Nm) using a calibrated torque wrench.

Check and Adjust Ignition and Ionization Electrodes

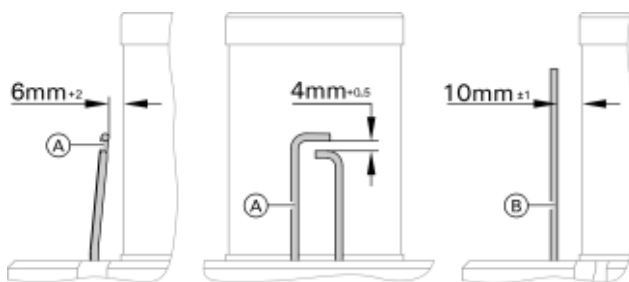

1. Check the ignition electrodes (A) and ionization electrode (B) for wear and contamination.
2. Clean electrodes with small brush (not a wire brush) or emery paper.
3. Check electrode gaps. If the gaps are not as specified, or the electrodes are damaged, replace and align the electrodes with new gaskets. Tighten the electrode fixing screws to a torque of 40 lb.in. (4.5 Nm) using a calibrated torque wrench.

Legend

- (A) Ignition electrodes
- (B) Ionization electrode

Cleaning the Heat Exchanger and Fitting the Burner

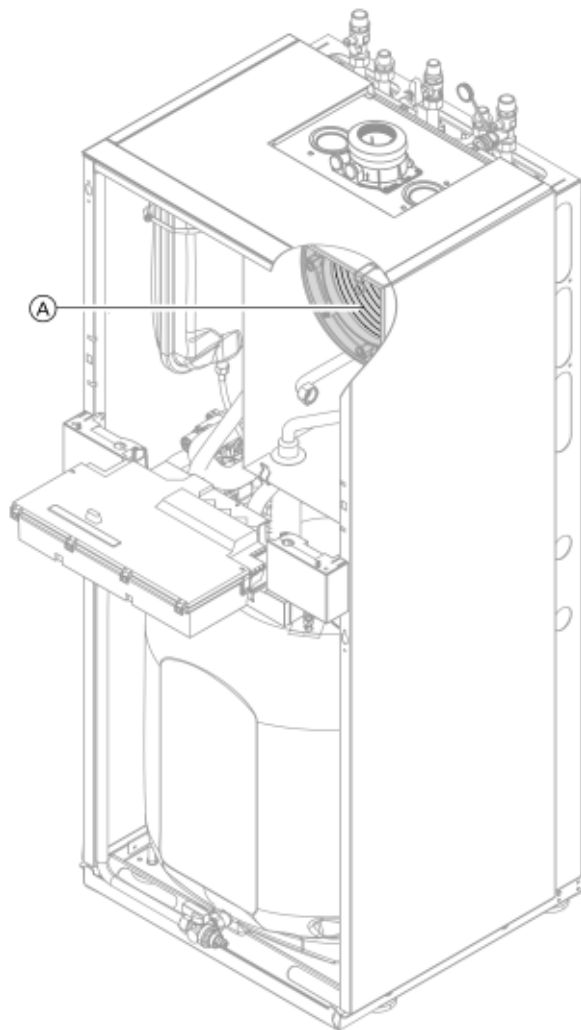

1. Remove front enclosure panel (if still installed) as per the instructions on page 11 in this manual, and reinstall panel upon completion of service work.
2. Remove burner assembly as per instruction on page 20.
Note: Be careful not to scratch parts which are in contact with flue gas. Use plastic brushes, not wire brushes!
 Follow Material Safety Data Sheet (MSDS) of the cleaning agent manufacturer.
 The cleaning agents must not contain hydrocarbon-based solvents or potassium.
3. Use a vacuum cleaner to remove residues from heat exchanger (A) inside the combustion chamber.
4. If necessary, clean the combustion chamber and heat exchanger surface (A) with a soft brush and/or rinse with water.
 Use solvent-free cleaning agents to remove residues:
 - Remove deposits of combustion by-products with alkaline agents containing tenside.
 - Remove coatings and (yellowish brown) surface discoloration with phosphoric acid-based "Antox 75 E Plus", or citric acid-based CitriSurft 3050 by Stellar Solutions Inc.
 - Rinse thoroughly with water.
 - Clean siphon (see page 23).
5. Install burner assembly.
6. Mount burner (four torx screws) and tighten diagonally to a torque of 75 lb.in. (8.5 Nm).
7. Fasten threaded connection for the gas connection hose with a new gasket or O-ring and torque to 6.3 lb.ft. (8.5 Nm).
8. Connect electrical cables to corresponding parts.

IMPORTANT

Perform gas leak test.

WARNING

Follow cleaning agent manufacturer's safety instructions and wear appropriate protective equipment.

WARNING

Never use a metal wire brush or mechanically driven brushes.

Checking the Condensate Drain and Cleaning the Siphon

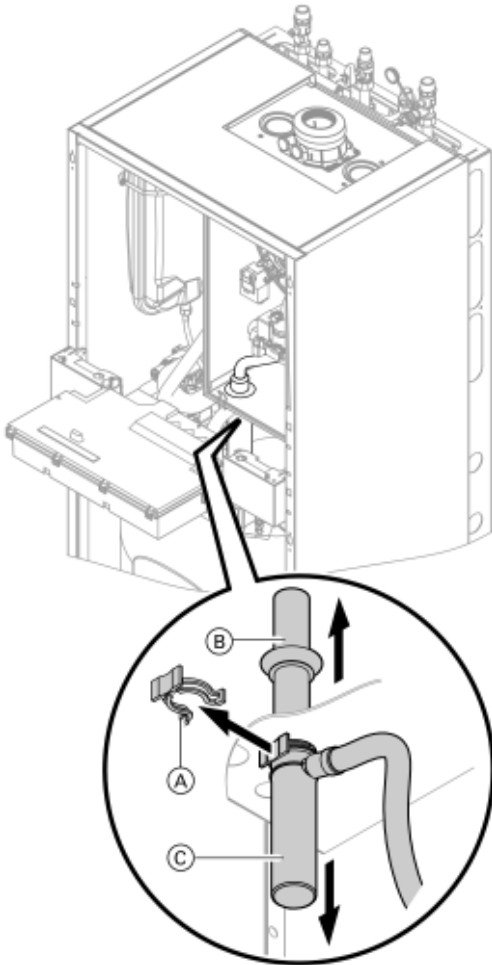

1. Check that the condensate can drain freely in the siphon.
2. Pull retaining clip (A) off.
3. Pull filler pipe (B) upwards.
4. Pull off trap (C) downwards.
5. Pull the condensate hose from trap (C).
6. Clean the siphon.
7. Fill siphon with water and reassemble.
8. Check that the condensate pipe is connected correctly to the siphon and heat exchanger.

IMPORTANT

If the condensate does not drain freely, condensate will accumulate in bottom part of boiler resulting in a burner shut-down (fault message).



Refer to Installation Instructions Neutralization Unit (if applicable)

Legend

- (A) Retaining clip
- (B) Siphon trap
- (C) Discharge tube

Check Neutralization Unit (if applicable)

1. Check the pH value of the condensate with pH measuring strip. If the pH value is less than 6.5, replace granulate.
2. If contaminated:
Rinse neutralization unit with tap water.
3. Add granulate as marked.



Refer to Installation Instructions Neutralization Unit (if applicable)

IMPORTANT

pH measuring strip must be field supplied.

IMPORTANT

The granulate is consumed as it neutralizes the condensate. The red marking indicates the minimum filling level.

Draining the Boiler on the DHW Side

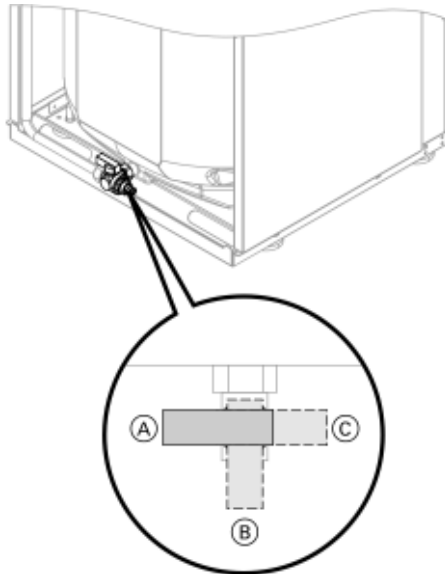

1. Connect hose to drain valve and route into a suitable container or drain outlet.

Note: Ensure adequate ventilation in the DHW pipework.

2. Turn drain valve from lever position (A) to lever position (B) or (C) as required.
 - Lever position (B): Drain drinking water circuit in appliance excluding DHW tank via the cold water connection.
 - Lever position (C): Drain potable water circuit in appliance and DHW tank via the hot water connection. Cold water connection remains filled.

Cleaning the DHW Storage Tank

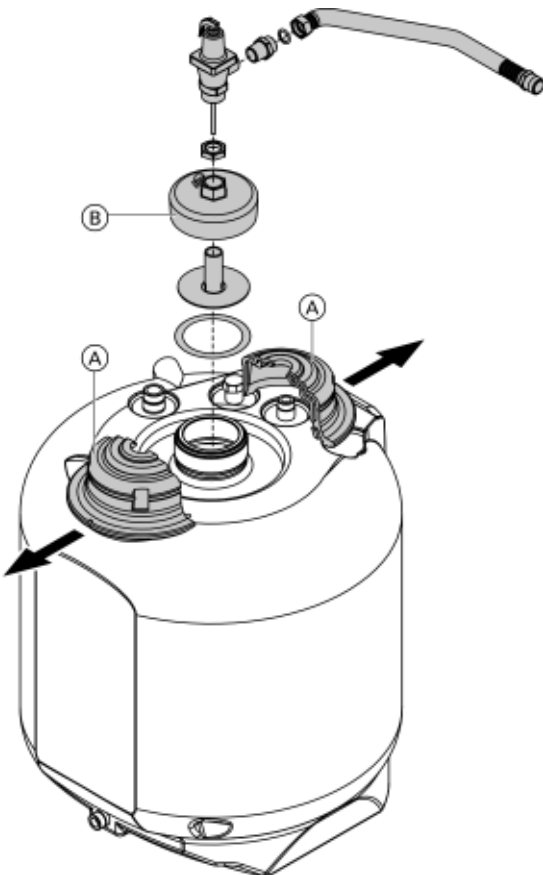

1. Drain the DHW storage tank.
2. Remove flange lid covers (A).
3. Disconnect the DHW piping from the pipework to prevent contamination from entering the pipe system.
4. Remove flange lid cover (B).
5. Remove loose deposits with a high pressure cleaner.

Note: When cleaning the inside, only use plastic cleaning utensils.
6. Use a chemical cleaning agent to remove hard deposits that cannot be removed by a high pressure cleaner.

Note: Never use hydrochloric acid based cleaning agents.
7. Thoroughly flush the DHW tank after cleaning.
8. Reinstall in reverse order.

Note: Visual inspection and (if necessary) cleaning must be carried out no later than two years after commissioning and thereafter as required.

Checking the Diaphragm Expansion Vessel and System Pressure

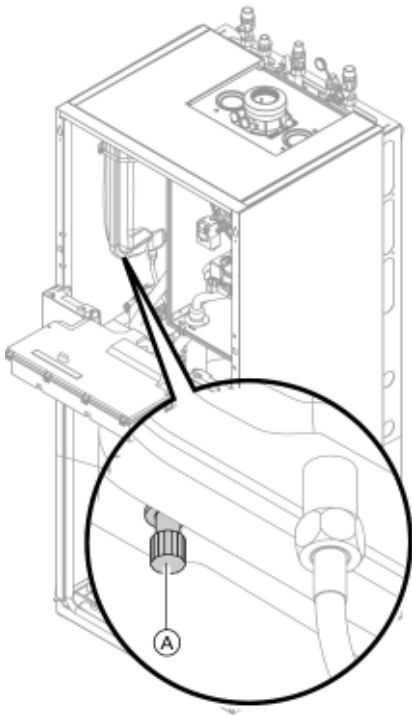

Perform check with the system cold.

1. If the nitrogen pressure of the precharged expansion tank is less than the static pressure of the system, top up with nitrogen via connection (A), until the inlet pressure is 1.4 to 2.9 psi higher than the static pressure of the system.
The static pressure required at the tank is based upon the static height of the system. The system fill pressure value must be equal to the expansion tank pressure value at approximately 60° F (15.6° C).
Note: Static head of 33 ft. (10 m) (distance between boiler and topmost heat emitter surface) corresponds to a static pressure of 15 psig.
2. Drain boiler/system and reduce pressure until the manometer reading is "0".
3. Top up with water until filling pressure is higher than the inlet pressure of the diaphragm expansion tank.
Note: With the system cold, the filling pressure must be 1.4 to 2.9 psi higher than the static pressure. Maximum operating pressure: 45 psig
Minimum operating pressure: 14 psig
4. When starting up the system for the first time, mark this value as the minimum filling pressure on the manometer.
Note: A lower manometer reading usually indicates loss of water due to leakage. All leaks must be repaired.

Check Functioning of Safety Valves

Ensure proper operation of low water cut-off(s) (if applicable), pressure relief valve, and pump(s).

Check pressure gage, air vent and pressure relief valve. Ensure that pressure relief valve does not leak and that it operates in accordance with information provided by the manufacturer.



Refer to maintenance instructions supplied with low water cut-offs, pumps, etc.

Flush float water type low water cut-offs (if used).

Follow local regulations with respect to backflow preventers.

If oil-lubricated system pumps are used, ensure proper lubrication.

If motorized zone valves are used, refer to maintenance instructions provided with zone valves.

Check Electrical Connections

Ensure all plug-in connectors and strain reliefs make positive contact and are seated properly.



Refer to the Installation Instructions

Check Gas Pipes and Fittings for Leaks

Note: For the tightness test, use only suitable and approved leak detecting agents and devices. Leak detecting agents with unsuitable contents (e.g. nitrites, sulphides) can lead to material damage. Remove residues of the leak detecting agent after testing.

WARNING

Escaping gas leads to a risk of explosion.
Check gas equipment for tightness.

WARNING

The gas supply piping must be leak tested before placing the boiler in operation.

CAUTION

Ensure all joints of gas line are pressure tight and that gas valves do not leak when under normal operating pressure (use approved leak detection liquid).

Clock Natural Gas Meter

Clock natural gas meter to verify input.

1. Ensure all other gas equipment served by the meter is turned off during timing of gas input to the Vitodens 222-F, B2TA boiler.
2. Measure the time in seconds it takes for the boiler to use 10 ft.³ of gas. Divide 3600 x 10 by the number of seconds and you get the number of ft.³ of gas used per hour. Multiply this number by the heating value of the gas to obtain Btu per hour input.

For example:

A Vitodens 222-F, B2TA 35 boiler (125 000 Btu/h input) requires 288 seconds to use 10 ft.³ of natural gas. After contacting the local utility, you will find the heating value is 1000 Btu per ft.³.

Therefore:

3,600 sec./h x 10 revolutions
 36,000/288 x 1000 @ 125 000 Btu/h input.
 The boiler input is correct.

Burner input formulas (for low altitude only):

INPUT = (3600t) x 1000 where

t = TIME (sec.) for 1 ft.³

INPUT = (3600 x .01 x 1000 x 35.31)T where

T = TIME (sec.) for .01 m³ natural gas

IMPORTANT

A boiler underfired by 5% is acceptable. Do not overfire the boiler.



CAUTION



Always contact your gas utility to obtain the correct heating value before clocking the meter.

Check CO₂ Setting

The Vitodens 222-F, B2TA boiler is equipped with the Lambda Pro Combustion Management System developed by Viessmann which ensures optimal combustion quality independent of gas quality and type. (For a description of the Lambda Pro Combustion Management System, see page 31 in this manual.) During initial start-up and maintenance you will only need to check the CO₂ and O₂ content at the boiler vent pipe adaptor.

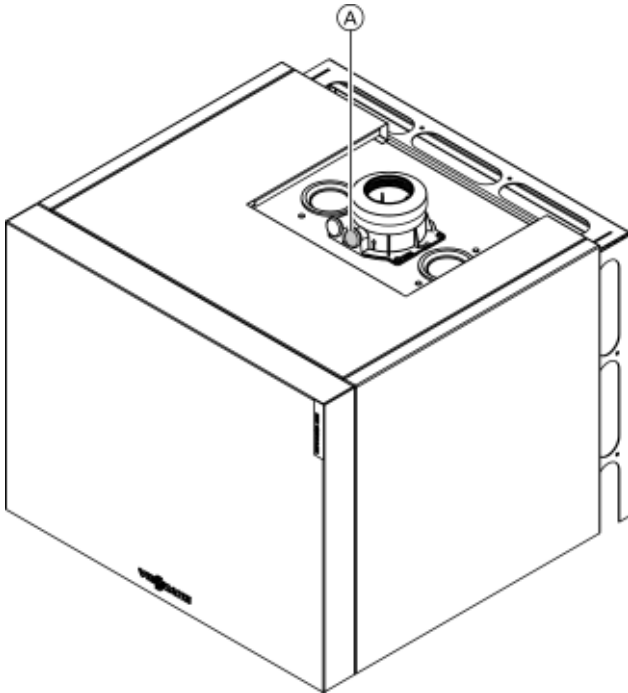
Note: The Vitodens 222-F, B2TA boiler comes factory set to operation with natural gas. (For instructions on how to convert to operation with liquid propane gas, see page 16.) For high-altitude operation above 5,000 ft. (1,500 m), see page 16. The MatriX cylinder burner of this boiler is preset for the entire gas group. No adjustment or readjustment of the burner is required.



1. Connect a flue gas analyzer to test port (A) at boiler vent pipe adaptor.
2. Open gas shut-off valve, start up boiler and create heat demand.
3. Select higher/lower output:
 - Press OK and  simultaneously for approximately 4 seconds.
 - "Actuator test"
 - Select lower output: "Base load ON" and confirm with OK.
 - Terminate with OK or .
4. Measure CO₂ and O₂ content at boiler vent pipe adaptor. If the measured values deviated by more than 1% from the acceptable ranges for the respective fuel type listed in the right column or in the table on page 16.
 - check the venting system for leaks (see subsection on page 20).
 - check that the boiler is set for the gas type used (see subsection on page 15).

Acceptable CO₂ content range:

 - 7.5 to 9.6% for natural gas
 - 9.0 to 11.3% for LPG

Acceptable O₂ content range:

 - 3.8 to 7.3% for all gas types
5. Enter measured values into the Maintenance Record on page 103.
6. Set boiler to full-fire by selecting "Full load ON". Confirm with OK.
7. Measure CO₂ and O₂ content at boiler vent pipe adaptor. If the measured values deviated by more than 1% from the acceptable ranges listed in the right column or in the table on page 16.
 - check the venting system for leaks (see subsection on page 20).
 - check that the boiler is set for the gas type used (see subsection on page 15).

Acceptable CO₂ content range:

 - 7.5 to 9.6% for natural gas
 - 9.0 to 11.3% for LPG

Acceptable O₂ content range:

 - 3.8 to 7.3% for all gas types
8. Press OK and  after testing and enter measured values into the Maintenance Record on page 103.

Start-up and Shutdown



Legend

- (A) Fault indicator (red)
- (B) ON indicator (green)
- (C) Reset button
- (D) ON/OFF switch
- (E) Pressure gauge

Starting the heating system

1. Check the heating system pressure at the pressure gauge. The heating system pressure is too low if the indicator points to the area below 15 psi. In this case, top up with water or notify your local heating contractor.
2. For room air dependent operation: Check that the ventilation apertures of the boiler room are open and unrestricted. **Note:** With room air dependent operation, the combustion air is drawn from the boiler room.
3. For Vitodens: Open the gas shut-off valve. **Note:** Ask your heating contractor to explain the positioning and handling of these components.
4. Switch ON the power supply, e.g. at a separate MCB/fuse or a mains isolator.
5. Turn the ON/OFF switch “(D)” ON. After a short time, the standard menu is displayed (see below) and the green ON indicator illuminates. Your heating system and, if installed, your remote controls are now ready for operation. **Note:** Slide the black control cover outwards to access the ON/OFF switch.

Menu

There are two control levels available, the “Standard menu” and the “Extended menu”.

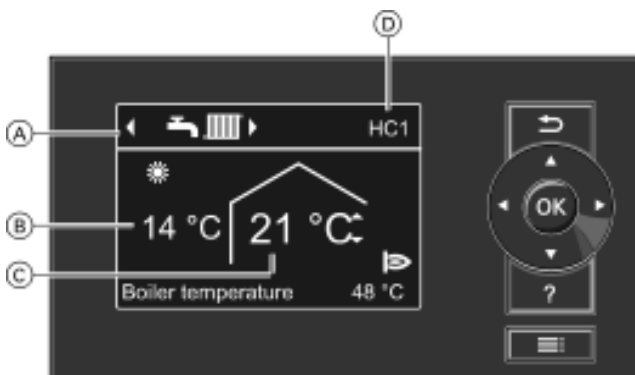

Legend

- (A) Header (shows the heating program for displayed heating circuit (D))
- (B) Current outside temperature
- (C) Set room temperature
- (D) Heating circuit which is selected for operation in the standard menu

Standard menu

Note: If your heating system has 2 or 3 heating circuits: You can select the heating circuit “HC1”, “HC2” or “HC3” to be displayed in the standard menu (see page 65).
If your heating system only has 1 heating circuit: No heating circuit name “HC...” is shown in the header.

In the standard menu, you can adjust and scan the most frequently used settings for the heating circuit shown in the header:

Press the following keys to set room temperature:

- ▲/▼ for the required value
- OK to confirm

Heating programs:

- ⏻ Standby mode with frost protection monitoring
- ☀ Only DHW
- ☀☀ Heating and DHW

Press the following keys:

- ▶/◀ for the required heating program
- OK to confirm

Note: 2 minutes after any setting has been made, the display automatically reverts to the standard menu.

Menu *(continued)*

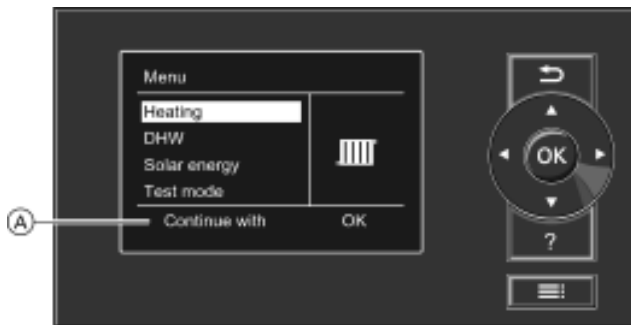

Legend

Ⓐ Dialogue line

Note: For any other connected heating circuits, use the settings in the extended menu.

Call up the standard menu as follows:

- If the screen saver is active (see extended menu below)
- Press any key except ?.

If you are somewhere in the menu:

Keep pressing ↶ until the standard menu appears.

Symbols on the display

These symbols are not always displayed, but appear subject to the system version and the operating state.

Heating programs

- Standby mode with frost protection monitoring
- Only DHW
- Heating and DHW

Displays

HC1 (2, 3) To display the heating circuit selected in the standard menu

- To change this, see operating instructions
- Frost protection monitoring
- Central heating with standard temperature
- Central heating with reduced temperature
- Party mode enabled
- Economy mode enabled

Messages

- Service message
- Fault message

Extended menu

In the extended menu, you can adjust and scan the settings from the control unit's range of functions used less frequently, (e.g. time programs and holiday programs). The menu overview can be found on page 66.

Call up the extended menu

If the screen saver is active:

Press any key except ?, and then press ≡.

If you are somewhere in the menu:

Press ≡.

How to use the controls

The screen saver will become active if you have not adjusted any settings on the programming unit for a few minutes. The display brightness is reduced.

Combustion Management System

The combustion management system utilizes the physical correlation between the level of the ionization current and the air factor λ (lambda). For all gas qualities, the maximum ionization current results with air factor λ .

The ionization signal is evaluated by the combustion management system, and the air factor is adjusted to between $\lambda = 1.24$ and 1.44 . This range provides for an optimum combustion quality. Thereafter, the electronic gas valve regulates the required gas volume based on the prevailing gas quality.

To check the combustion quality, the CO₂ content or the O₂ content of the flue gas is measured. The actual values enable the prevailing air factor to be determined.

Air factor λ - CO₂/O₂ content

The relationship between the CO₂ or O₂ content and air factor λ is illustrated in the table below.

To achieve an optimum combustion control, the system regularly performs an automatic self-calibration; also after a power failure (shutdown). For this, the combustion is briefly regulated to max. ionization current (equals air factor $\lambda = 1$). The automatic calibration is performed shortly after the burner starts and lasts approximately 5 seconds.

During the calibration, higher than normal CO emissions may occur briefly.

The combustion management system can also be calibrated manually, e.g. after maintenance or service work (coding address "85", see Service Instructions).

Air factor λ	O ₂ content (%)	CO ₂ content (%) for natural gas	CO ₂ content (%) for liquid propane gas
1.20	3.8	9.6	11.3
1.24	4.4	9.2	10.9
1.27	4.9	9.0	10.6
1.30	5.3	8.7	10.3
1.34	5.7	8.5	10.0
1.37	6.1	8.3	9.8
1.40	6.5	8.1	9.6
1.44	6.9	7.8	9.3
1.48	7.3	7.6	9.0

The Vitodens 222-F, B2TA boilers come equipped with Lambda Pro, the industry's first intelligent combustion management system. The boiler adjusts automatically to any gas type and quality without the need for a fuel conversion kit.

Functional Description

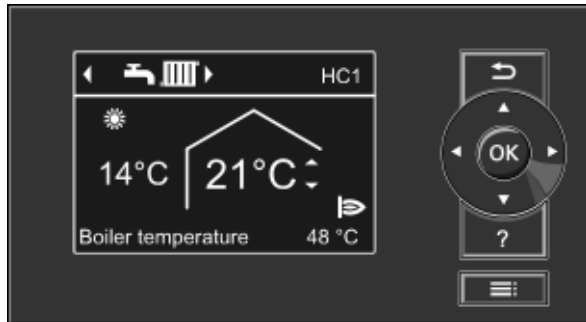

Heating mode

The control unit determines a set boiler water temperature subject to outside temperature or room temperature (if a room temperature-dependent remote control is connected) and to the slope/ shift of the heating curve. The determined set boiler water temperature is transferred to the burner control unit. From the set and actual boiler water temperatures, the burner control unit calculates the modulation shift and regulates the burner accordingly. The electronic temperature limiter inside the burner control unit limits the boiler water temperature.

Heating the DHW primary tank from cold

The heating circuit pump is switched ON and the three-way diverter valve will be changed over, if the DHW tank temperature sensor captures a temperature lower than the defaulted set temperature.

- The DHW tank primary pump is switched ON if the boiler water temperature \geq set DHW temperature.
- The burner is switched ON if the boiler water temperature \leq set DHW temperature, and the DHW tank primary pump is switched ON when the required boiler water temperature is reached.

The primary DHW tank is heated up to the set DHW temperature. Heating stops when the set temperatures have been reached at the DHW tank temperature sensor and at the outlet temperature sensor.

After heating, the DHW tank primary pump and the three-way diverter valve remain ON for a further 30 sec.

Boosting when DHW is drawn off

When DHW is drawn off, cold water enters at the bottom of the primary DHW tank.

The heating circuit pump is switched ON and the three-way diverter valve is changed over, if the DHW tank temperature sensor recognizes a temperature lower than the set temperature.

- The DHW tank primary pump is switched ON if the boiler water temperature \geq set DHW temperature.
- The burner is switched ON if the boiler water temperature \leq set DHW temperature, and the DHW tank primary pump is switched ON when the required boiler water temperature is reached.

The DHW is controlled to the specified temperature via the DHW tank temperature sensor.

The primary DHW tank continues to be heated up after the draw off process has terminated, until the set DHW temperature has been reached at the DHW tank temperature sensor.

The DHW tank primary pump and the three-way diverter valve remain ON for a further 30 sec.

Boosting DHW heating

The booster heating function is activated if a switching period is selected for the fourth time phase.

The set temperature value for the heating boost is adjustable in coding address "58".

Installation Examples

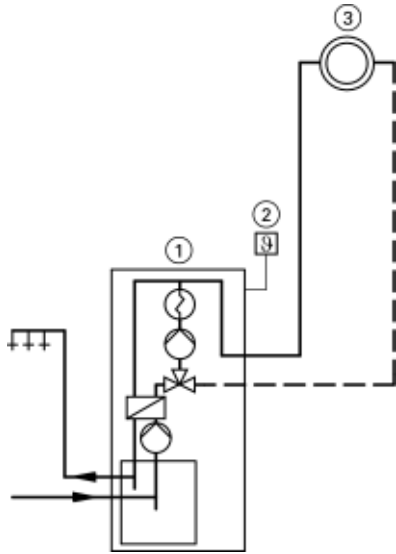

Legend

- ① Vitodens 222-F
- ② Outside temperature sensor
- ③ Heating circuit without mixing valve A1 (heating circuit 1)

Matching the control unit to the heating system

The control unit must be matched to the equipment level of the system. Various system components are recognized automatically by the control unit and the relevant codes are adjusted automatically.

- For the selection of an appropriate type, see the following diagrams.
- For coding steps, starting on page 42.

System version 1

One heating circuit without mixing valve A1

Function/system components	Code	
	Adjust	Factory set condition
Operation with LPG	82:1	82:0
System with DHW circulation pump: DHW circulation pump connection at extension AM1, terminal A2	-	34:0

Installation Examples *(continued)*

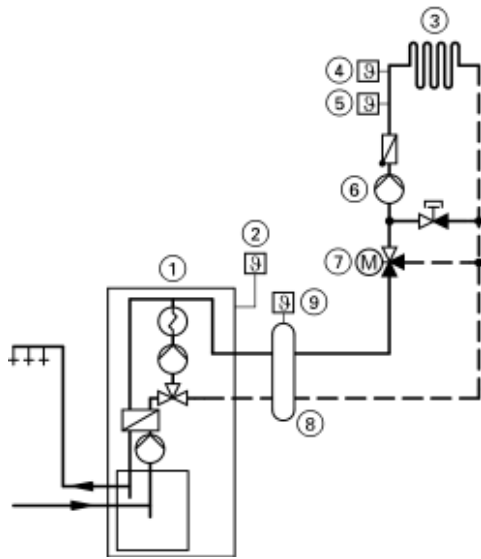

Legend

- ① Vitodens 222-F
- ② Outside temperature sensor
- ③ Heating circuit with mixing valve M2 (heating circuit 2)
- ④ Temperature limiter for limiting the maximum temperature of underfloor heating systems
- ⑤ Supply temperature sensor M2
- ⑥ Heating circuit pump M2
- ⑦ Extension kit for one heating circuit with mixing valve M2
- ⑧ Low loss header
- ⑨ Supply temperature sensor, low loss header

System version 2

One heating circuit with mixing valve M2 and a low loss header

Function/system components	Code	
	Adjust	Factory set condition
Operation with LPG	82:1	82:0
System only with one heating circuit with mixing valve with extension kit for mixing valve (without unregulated heating circuit) with DHW heating	00:4	00:6
System with DHW circulation pump:	-	34:0
System with low loss header	04:0	04:1

Installation Examples *(continued)*

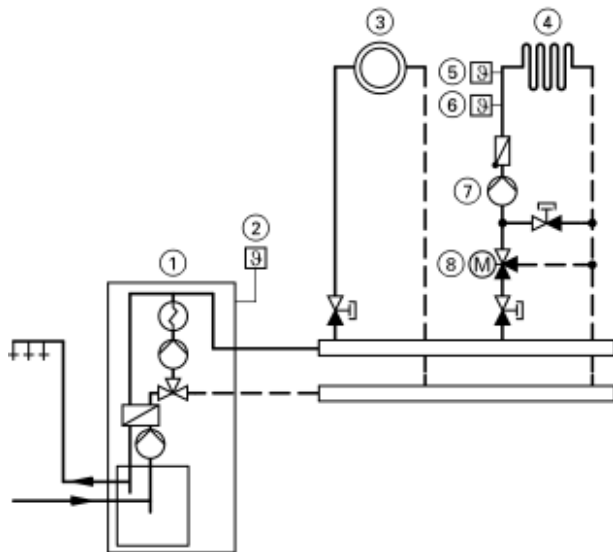

Legend

- ① Vitodens 222-F
- ② Outside temperature sensor
- ③ Heating circuit without mixing valve A1 (heating circuit 1)
- ④ Heating circuit with mixing valve M2 (heating circuit 2)
- ⑤ Temperature limiter for limiting the maximum temperature of underfloor heating systems
- ⑥ Supply temperature sensor M2
- ⑦ Heating circuit pump M2
- ⑧ Extension kit for one heating circuit with mixing valve M2

System version 3

One heating circuit without mixing valve A1 and one heating circuit with mixing valve M2

Function/system components	Code	
	Adjust	Factory set condition
Operation with LPG	82:1	82:0
System only with one heating circuit with mixing valve with extension kit for mixing valve (without unregulated heating circuit) with DHW heating	00:4	00:6
System with DHW circulation pump: DHW circulation pump connection at extension AM1, terminal A2	-	34:0

Note: The flow rate of the heating circuit without mixing valve must be at least 30% greater than the flow rate of the heating circuit with mixing valve.

Installation Examples *(continued)*

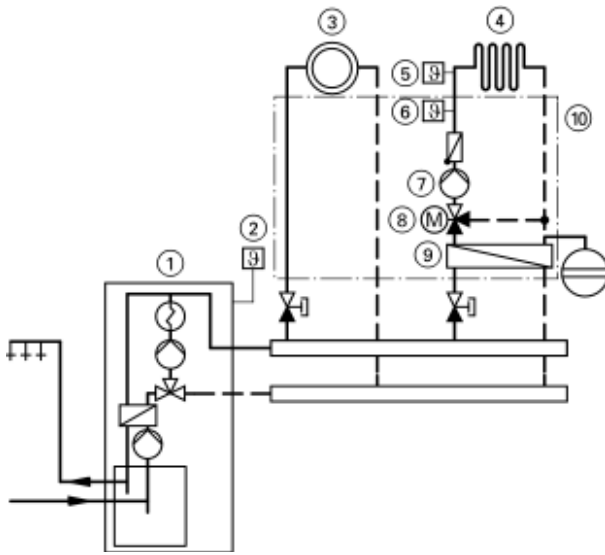

Legend

- ① Vitodens 222-F
- ② Outside temperature sensor
- ③ Heating circuit without mixing valve A1 (heating circuit 1)
- ④ Heating circuit with mixing valve M2 (heating circuit 2)
- ⑤ Temperature limiter for limiting the maximum temperature of underfloor heating systems
- ⑥ Supply temperature sensor M2
- ⑦ Heating circuit pump M2
- ⑧ Extension kit for one heating circuit with mixing valve M2
- ⑨ Heat exchanger for system separation
- ⑩ Assembly kit with mixing valve (accessory)

System version 4

One heating circuit without mixing valve A1, one heating circuit with mixing valve M2 and system separation

Function/system components	Code	
	Adjust	Factory set condition
Operation with LPG	82:1	82:0
System only with one heating circuit with mixing valve with extension kit for mixing valve (without unregulated heating circuit) with DHW heating	00:4	00:6
System with DHW circulation pump: DHW circulation pump connection at extension AM1, terminal A2	-	34:0

Installation Examples *(continued)*

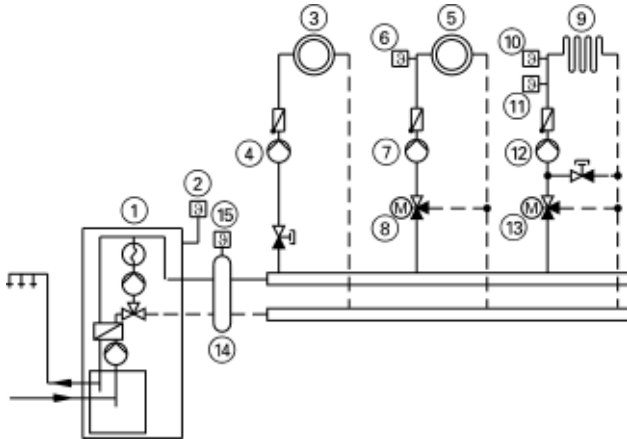

Legend

- ① Vitodens 222-F
- ② Outside temperature sensor
- ③ Heating circuit without mixing valve A1 (heating circuit 1)
- ④ Heating circuit pump A1
- ⑤ Heating circuit with mixing valve M2 (heating circuit 2)
- ⑥ Supply temperature sensor M2
- ⑦ Heating circuit pump M2
- ⑧ Extension kit for one heating circuit with mixing valve M2
- ⑨ Heating circuit with mixing valve M3 (heating circuit 3)
- ⑩ Temperature limiter for limiting the maximum temperature of underfloor heating systems
- ⑪ Supply temperature sensor M3
- ⑫ Heating circuit pump M3
- ⑬ Extension kit for one heating circuit with mixing valve M3
- ⑭ Low loss header
- ⑮ Supply temperature sensor, low loss header

System version 5

One heating circuit without mixing valve, one heating circuit with mixing valve M2 (with extension kit), one heating circuit with mixing valve M3 (with extension kit) and low loss header (with/without DHW heating)

Function/system components	Code	
	Adjust	Factory set condition
Operation with LPG	82:1	82:0
System only with two heating circuits with mixing valve with extension kit for mixing valve (without unregulated heating circuit) with DHW heating	00:8	00:10
Heating circuit pump A1 connection at extension AM1, terminal A1	-	33:1
DHW circulation pump connection at extension AM1, terminal A2	-	34:0
System with low loss header	04:0	04:1
External heating circuit pump, heating circuit A1	53:2	53:1

Heating Curve Adjustment

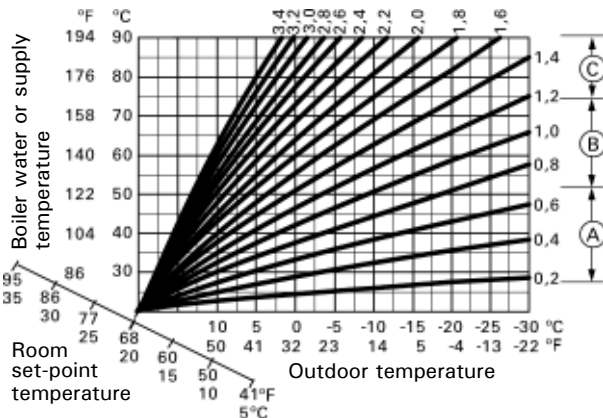

- Ⓐ Low-temperature heating system, e.g. radiant floor heating, 0.2 - 0.7
- Ⓑ Medium-temperature heating system, e.g. cast iron radiation, staple-up radiant floor heating, 0.7 - 1.2
- Ⓒ High-temperature heating system, e.g. fintube radiation, fan coils, 1.2 - 1.5

The heating curves represent the relationship between the outdoor temperature and the boiler water or supply temperature.

Put simply: The lower the outdoor temperature, the higher the boiler water or supply temperature.

In turn, the room temperature is dependent on the boiler water or supply temperature.

If a different room temperature is set, the curves are shifted parallel to the desired room temperature axis.

The control unit regulates the boiler water temperature (= supply temperature of heating circuit without mixing valve) and the supply temperature of the heating circuit with mixing valve (in conjunction with the accessory kit for a heating circuit with mixing valve) according to the outdoor temperature. The boiler water temperature is automatically raised by 0 to 72 F / 0 to 40 K higher than the currently required set supply temperature (in the factory default setting the differential temperature is 14.4 F / 8 K). See coding address "9F" in General Group.

The supply temperature that is required to achieve a given room temperature depends on the heating system and the thermal insulation of the building that is being heated.

The adjustment of the two heating curves is used to match the boiler water temperature and the supply temperature to these conditions. The boiler water temperature is limited upwards by the fixed high limit and the temperature set for the electronic high limit.

The supply temperature cannot rise above the boiler water temperature.

Factory settings:

- slope = 1.4
- shift = 0

Note: If the heating system includes heating circuits with mixing valves, then the supply temperature of the heating circuit without mixing valve is higher by a selected differential (8 K in the factory setting) than the supply temperature of the heating circuits with mixing valves. The differential temperature can be changed at coding address 9F.

Heating Curve Adjustment *(continued)*

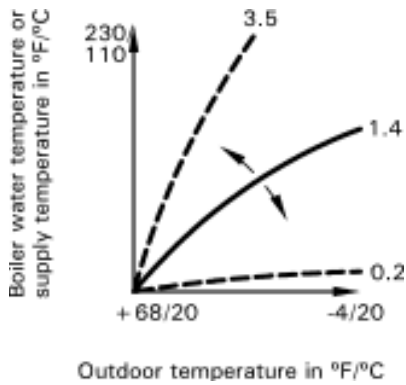

Changing the slope and shift

Extended menu:

- 1.
2. Select "Heating" - **OK**
3. Heating circuit selection
4. Accept with **OK**
5. Heating curve - **OK**
6. Slope or shift - **OK**
7. Change with
8. Select heating curve according to the system requirements.
9. Exit

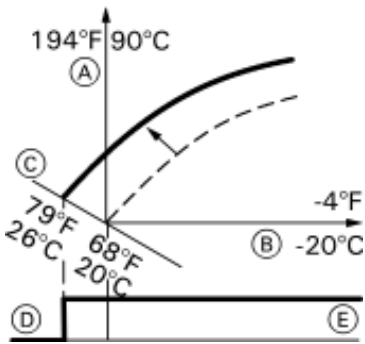

Example 1: Adjusting the room temperature setpoint from 79° F to 68° F (20° C to 26° C)

Standard Room Temperature

- 1.
2. Select "Heating"
3. Heating circuit selection
4. **OK**
5. Room temperature setpoint - OK
6. Change with
7. Accept with **OK**
- 8.



Refer to the Operating Instructions

- (A) Boiler water temperature / Supply temperature
- (B) Outdoor temperature
- (C) Room temperature setpoint
- (D) Heating circuit pump "OFF"
- (E) Heating circuit pump "ON"

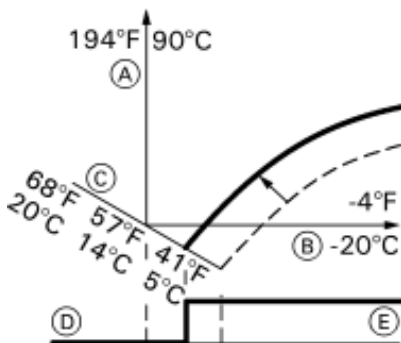

Example 2: Adjusting the room temperature setback from 41° F to 57° F (5° C to 14° C)

Room Temperature Setback

- 1.
2. Select "Heating"
3. Heating circuit selection
4. **OK**
5. Red room temperature setpoint - OK
6. Change with
7. Accept with **OK**
- 8.



Refer to the Operating Instructions.

- (A) Boiler water temperature / Supply temperature
- (B) Outdoor temperature
- (C) Room temperature setpoint in
- (D) Heating circuit pump "OFF"
- (E) Heating circuit pump "ON"

Connecting the Boiler Control to a LON System

The LON communication module (accessory) must be connected.

Note: The data transfer via the LON can take several minutes.

Note: In the same LON system, the same participant number cannot be allocated twice. Only one Vitotronic may be programmed as fault manager.

Single boiler system with Vitotronic 200-H, HK1B mixing valve control and Vitocom LON communication module



Refer to the Installation Instructions for the LON communication module

Set the LON participant numbers and other functions via coding level 2 (see table below)

Boiler control unit	Vitotronic 200-H (e.g. HK1B *1 mixing valve control)	Vitotronic 200-H (e.g. HK1B *1 multiple mixing valve control)	Vitocom *1 LON communication module
Participant no. 1 Code "77:1"	Participant no. 10 Code "77:10"	Participant no. 11 Set code "77:11"	Participant no. 99
Control unit is fault manager Code "79:1"	Control unit is not fault manager Code "79:0"	Control unit is not fault manager Code "79:0"	Device is fault manager
Control unit transmits the time Code "7B:1"	The control unit receives the time Set code "81:3"	The control unit receives the time Set code "81:3"	Device receives the time
Control unit transmits outside temperature Set code "97:2"	Control unit receives outside temperature Set code "97:1"	Control unit receives outside temperature Set code "97:1"	--
LON participant fault monitoring Code "9C:20"	LON participant fault monitoring Code "9C:20"	LON participant fault monitoring Code "9C:20"	--

*1 Refer to the separate Installation Instructions of accessories.

Connecting the Boiler Control to a LON System *(continued)*

Updating the LON participant list

Only possible if all participants are connected and the control unit is programmed to be fault manager (coding address "79:1").

Performing a LON participant check

Communication with the system devices connected to the fault manager is tested by means of a participant check.

Preconditions:

- The control unit must be programmed as fault manager (code "79:1")
- The LON participant number must be programmed in all control units (see page 40)
- The LON participant list in the fault manager must be up to date

Performing the participant check:

1. Press OK and  simultaneously for approximately 4 seconds.
2. "Service functions"
3. "Participant check"
4. Select participant (e.g. participant 10).

The participant check for the selected participant is initiated.

- Successfully tested participants are designated with "OK".
- Unsuccessfully tested participants are designated with "Not OK".

Note: To carry out a new participant check, create a new participant list with menu item "Delete list?"

Note: If the participant check is carried out by another control unit, the participant number and "Wink" are shown on the display for approx. 1 minute.

Scanning and resetting the "Service" display

After the limits specified in coding addresses "21" and "23" have been reached, the red fault indicator flashes and the following appears on the programming unit display:

- "Service" and 

Scanning and resetting service display

Press **OK** to acknowledge a service message.

Note: An acknowledged service message that was not reset reappears:

- On the following Monday.

After a service has been carried out (reset service)

1. Press OK and  simultaneously for approximately 4 seconds.
2. "Service functions"
3. "Service reset"

Note: The selected service parameters for hours run and time interval restart at 0.

Instructing the system user

The system installer must hand the operating instructions to the system user and instruct the user in the operation of the system.

General

Accessing coding level 1

Note: Codes are displayed as plain text.

Codes that have no function due to the heating system equipment level or the setting of other codes are not displayed.

Heating systems with one heating circuit without mixing valve and one or two heating circuits with mixing valve:

The heating circuit without a mixing valve is designated "Heating circuit 1" and the heating circuits with mixing valve as "Heating circuit 2" or "Heating circuit 3".

If the heating circuits were given individual designations, the selected designation and "HC1", "HC2" or "HC3" appear instead:

Select "General"

Coding			
Coding in the factory setting		Possible change	
System design			
00:2	System type 1: One heating circuit without mixing valve A1 (heating circuit 1),	00:2 to 00:10	For system type, see the following table:

Value address	System type	Description
00: ...		
2	1	One heating circuit without mixing valve A1 (heating circuit 1), (code is adjusted automatically).
4	2	One heating circuit with mixing valve (heating circuit 2).
6	3, 4	One heating circuit without mixing valve A1 (heating circuit 1) and one heating circuit with mixing valve M2 (heating circuit 2), (code is adjusted automatically).
8	5	One heating circuit with mixing valve M2 (heating circuit 2) and one heating circuit with mixing valve M3 (heating circuit 3), (code is adjusted automatically).
10	5	One heating circuit without mixing valve A1 (heating circuit 1), one heating circuit with mixing valve M2 (heating circuit 2) and one heating circuit with mixing valve M3 (heating circuit 3), (code is adjusted automatically).

1. Press **OK** and **≡**; simultaneously for approximately 4 seconds.
2. "Coding level 1"
3. Select group of required coding address:
 - "General"
 - "Boiler"
 - "DHW"
 - "Heating circuit 1/2/3"
 - "All codes std device"

In this group, all coding addresses from coding level 1 (except the coding addresses from the "Solar" group) are displayed in ascending order.
4. Select coding address.
5. Select value according to the following tables and confirm with **OK**.
6. If you want to reset all codes to their factory setting: Select "Standard setting" in "Coding level 1".

Note: This also resets codes from coding level 2.

General *(continued)*

Coding in the factory set mode		Possible change	
Internal circulation pump function			
51:0	Internal circulation pump always starts when there is a heat demand	51:1	System with low loss header: When there is a heat demand, the internal circulation pump is only started if the burner is operational. Circulation pump is switched off when run-on time expires.
		51:2	System with heating water buffer tank: When there is a heat demand, the internal circulation pump is only started if the burner is operational. Circulation pump is switched off when run-on time expires.
Participant no.			
77:1	LON participant number	77:2 to 77:99	LON participant number, adjustable from 1 to 99: 1 = Boiler 10 - 98 = Vitotronic 200-H 99 = Vitocom Note: Allocate each number only once.
Detached house/apartment building			
7F:1	Detached house	7F:0	Apartment building Separate adjustment of holiday program and time program for DHW heating possible.
Lock out controls			
8F:0	Operation in the standard menu and extended menu enabled. Note: The respective code is only activated when you exit the service menu.	8F:1	Operation in standard menu and extended menu blocked. Emissions test mode can be enabled.
		8F:2	Operation enabled in the standard menu and blocked in the extended menu. Emissions test mode can be enabled.
Set supply temperature for external demand			
9B:70	Set supply temperature for external demand 158° F (70° C)	9B:0 to 9B:127	Set supply temperature for external demand adjustable from 32 to 260° F (0 to 127°C) (limited by boiler-specific parameters).

Boiler

Select "Boiler"

Coding in the factory setting		Possible change	
Single/multi boiler system			
Boiler number			
Burner service in 100 hours			
21:0	No service interval (hours run) selected	21:1 to 21:100	Number of hours run before the burner should be serviced is adjustable from 100 to 10,000 h One adjusting step Δ 100 h.
Service interval in months			
23:0	No time interval for burner service	23:1 to 23:24	Interval adjustable from 1 to 24 months.
Service status			
24:0	No "Service" display	24:1	"Service" display (the address is automatically set and must be manually reset after a service has been carried out).
Filling/Venting			
2F:0	Venting (bleeding) program/fill program disabled	2F:1	Venting (bleeding) program enabled.
		2F:2	Fill program enabled.

DHW

Select "DHW"

Coding in the factory setting		Possible change	
Enable DHW circulation pump			
73:0	DHW recirculation pump: "ON" in accordance with the time program	73:1 to 73:6	"ON" from once per hour for 5 minutes up to 6 times per hour for 5 minutes during the time program.
		73:7	Constantly "ON".

Heating Circuit 1, 2 and 3

Select "Heating circuit ..."

Coding

Coding in the factory setting		Possible change	
Economy function outside temperature			
A5:5	With heating circuit pump logic function (economy mode): Heating circuit pump "OFF" when the outside temperature (AT) is 1 K higher than the set room temperature (RTset) AT > RTset + 1 K	A5:0	Without heating circuit pump logic function.
		A5:1 to A5:15	With heating circuit pump logic function: Heating circuit pump "OFF"; see following table.

Parameter address A5:...	With heating circuit pump logic function: Heating circuit pump "OFF"
1	AT > RTset + 5 K
2	AT > RTset + 4 K
3	AT > RTset + 3 K
4	AT > RTset + 2 K
5	AT > RTset + 1 K
6	AT > RTset
7	AT > RTset - 1 K
to	
15	AT > RTset - 9 K

Coding in the factory setting		Possible change	
Extended economy function adjusted outside temperature			
A6:36	Extended economy function disabled	A6:5 to A6:35	Extended economy function enabled, i.e. the burner and heating circuit pump will stop and the mixing valve close at a variable value, adjustable between 41 and 95° F (5 and 35° C) plus 1.8° F (1° C). The base value is the adjusted outside temperature. This value is based on the actual outside temperature and a time constant, which takes the cooling down of an average building into consideration.

Heating Circuit 1, 2 and 3 *(continued)*

Coding in the factory setting		Possible change	
Extended economy function mixing valve			
A7:0	Without mixing valve economy function	A7:1	With mixing valve economy function (extended heating circuit pump logic): Heating circuit pump also "OFF": - If the mixing valve has been closed for longer than 20 minutes. Heating circuit pump "ON": - If the mixing valve changes to control function. - If there is a risk of frost.
Pump idle time, transition reduced mode			
A9:7	With pump idle time: Heating circuit pump "OFF" if the set value is altered through a change in operating mode or through a change in the set room temperature	A9:0	Without pump idle time
		A9:1 to A9:15	With pump idle time, adjustable from 1 to 15. 1 = Short idle period 2 = Long idle period
Room temperature hook-up			
B0:0	Only with heating circuit with mixing valve and remote control. Heating mode and reduced mode.	B0:1	Heating mode: weather-compensated Reduced mode: with room temperature hook-up.
		B0:2	Heating mode: with room temperature hook-up Reduced mode.
		B0:3	Heating mode/reduced mode: with room temperature hook-up.
Economy function room temperature			
B5:0	With remote control: No room temperature dependent heating circuit pump logic function	B5:1 to B5:8	Heating circuit pump logic function, see the following table:

Parameter address	With heating circuit pump logic function:	
	Heating circuit pump "OFF"	Heating circuit pump "ON"
B5:...		
1	$RT_{actual} > RT_{set} + 5\text{ K}$	$RT_{actual} < RT_{set} + 4\text{ K}$
2	$RT_{actual} > RT_{set} + 4\text{ K}$	$RT_{actual} < RT_{set} + 3\text{ K}$
3	$RT_{actual} > RT_{set} + 3\text{ K}$	$RT_{actual} < RT_{set} + 2\text{ K}$
4	$RT_{actual} > RT_{set} + 2\text{ K}$	$RT_{actual} < RT_{set} + 1\text{ K}$
5	$RT_{actual} > RT_{set} + 1\text{ K}$	$RT_{actual} < RT_{set}$
6	$RT_{actual} > RT_{set}$	$RT_{actual} < RT_{set} - 1\text{ K}$
7	$RT_{actual} > RT_{set} - 1\text{ K}$	$RT_{actual} < RT_{set} - 2\text{ K}$
8	$RT_{actual} > RT_{set} - 2\text{ K}$	$RT_{actual} < RT_{set} - 3\text{ K}$

Heating Circuit 1, 2 and 3 *(continued)*

Coding in the factory setting		Possible change	
Minimum supply temperature heating circuit			
C5:20	Electronic minimum supply temp. limit 68° F (20° C)	C5:1 to C5:127	Minimum limit adjustable from 34 to 260° F (1 to 127° C) (limited by boiler-specific parameters).
Minimum supply temperature heating circuit			
C6:74	Electronic maximum supply temperature limit 165° F (74° C)	C6:10 to C6:127	Maximum limit adjustable from 50 to 260° F (10 to 127° C) (limited by boiler-specific parameters).
Heating program - changeover			
D5:0	The external heating program changeover changes the heating program to "Constant operation with reduced room temperature" or "Standby mode"	D5:1	The external heating program changeover changes to "Constant operation with standard room temperature" (subject to coding address 3A, 3B and 3C).
Ext. heating program changeover to heating circuit			
D8:0	No heating program changeover via extension EA1	D8:1	Heating program changeover via input DE1 at extension EA1.
		D8:2	Heating program changeover via input DE2 at extension EA1.
		D8:3	Heating program changeover via input DE3 at extension EA1.
Maximum pump speed in standard mode			
E6:... DO NOT ADJUST	Maximum speed of the variable speed heating circuit pump in % of the maximum speed in standard mode. Value is specified by boiler-specific parameters.	E6:0 to E6:100	Maximum speed adjustable from 0 to 100%.
Minimum pump speed			
E7:30 DO NOT ADJUST	Minimum speed of the variable speed heating circuit pump: 30% of the maximum speed.	E7:0 to E7:100	Minimum speed adjustable from 0 to 100% of the maximum speed.
Slab curing function			
F1:0 NOT USED	slab curing function disabled	F1:1 to F1:6	--
		F1:15	--
Party mode time limit			
F2:8	Time limit for party mode or external heating program changeover via pushbutton: 8 h*1	F2:0	No time limit for party mode*1.
		F2:1 to F2:12	Time limit adjustable from 1 to 12 h*1.

*1 Party mode ends automatically in the "Heating and DHW" program, when the system changes over to operation with standard room temperature.

Heating Circuit 1, 2 and 3 *(continued)*

Coding in the factory setting		Possible change	
Pump control in "Only DHW"			
F6:25	In the "Only DHW" operating mode, the internal circulation pump is permanently on	F6:0	In the "Only DHW" operating mode, the internal circulation pump is permanently OFF.
		F6:1 to F6:24	In the "Only DHW" operating mode, the internal circulation pump will be started 1 to 24 times per day for 10 minutes each time.
Pump control in "Standby mode"			
F7:25	In the "Standby" operating mode, the internal circulation pump in the heating circuit is permanently ON	F7:0	In the "Standby" operating mode, the internal circulation pump in the heating circuit is permanently OFF.
		F7:1 to F7:24	In the "Standby" operating mode, the internal circulation pump in the heating circuit connection set will be started 1 to 24 times per day for 10 minutes each time.
Start temperature raising			
F8:-5	Temperature limit for terminating the reduced mode 23° F (-5° C); See operating instructions. Observe the setting of coding address "A3"	F8: + 10 to F8:-60	Temperature limit adjustable from + 50 to -76° F (+ 10 to -60° C).
		F8:-61	Function disabled.
End temperature raising			
F9:-14	Temperature limit for raising the reduced set room temperature 6.8° F (-14° C); See operating instructions.	F9: + 10 to F9:-60	Temperature limit for raising the set room temperature to the value selected for standard mode adjustable from 50 to -76° F (10 to -60° C).
Set supply temperature heating circuit			
FA:20	Raising the set boiler water temperature or the set supply temperature when changing from operation with reduced room temperature to operation with standard room temperature, by 20%. See operating instructions.	FA:0 to FA:50	Temperature rise adjustable from 0 to 50%.
Duration set supply temperature increase			
FB:60	Duration for raising the set boiler water temperature or the set supply temperature (see coding address "FA") 60 minutes. See operating instructions.	FB:0 to FB:300	Duration adjustable from 0 to 300 minutes;

General

Calling up coding level 2

Note: At coding level 2, all codes are accessible, including the codes at coding level 1.

Codes that have not been assigned due to the heating system equipment level or the setting of other codes are not displayed.

Heating systems with one heating circuit without mixing valve and one or two heating circuits with mixing valve:

The heating circuit without mixing valve is designated "Heating circuit 1" and the heating circuits with mixing valve as "Heating circuit 2" or "Heating circuit 3".

If the heating circuits were given individual designations, the selected designation and "HC1", "HC2" or "HC3" appear instead:

1. Press **OK** and **≡** simultaneously for approximately 4 seconds
 2. Press **OK** and **↶** simultaneously for approximately 4 seconds
 3. "Coding level 2"
 4. Select group of required coding address:
 - "General"
 - "Boiler"
 - "DHW"
 - "Heating circuit 1/2/3"
 - "All codes std device"

In this group, all coding addresses (except the coding addresses from the "Solar" group) are displayed in ascending order.
 5. Select coding address.
 6. Select value according to the following tables and confirm with **"OK"**.
 7. If you want to reset all codes to their factory setting: Select "Standard setting" in "Coding level 2".
- Note:** This also resets codes at coding level 1.

Select "General"

Coding

Coding in the factory setting		Possible change	
00:2	System type 1: One heating circuit without mixing valve A1 (heating circuit 1)	00:2 to 00:10	For system type, see the following table:

Value address 00: ...	System type	Description
2	1	One heating circuit without mixing valve A1 (heating circuit 1), (code is adjusted automatically).
4	2	One heating circuit with mixing valve (heating circuit 2).
6	3, 4	One heating circuit without mixing valve A1 (heating circuit 1) and one heating circuit with mixing valve M2 (heating circuit 2), (code is adjusted automatically).

General *(continued)*

Value address 00: ...	System version	Description
8	5	One heating circuit with mixing valve M2 (heating circuit 2) and one heating circuit with mixing valve M3 (heating circuit 3), (code is adjusted automatically).
10	5	One heating circuit without mixing valve A1 (heating circuit 1), one heating circuit with mixing valve M2 (heating circuit 2) and one heating circuit with mixing valve M3 (heating circuit 3), (code is adjusted automatically).

Coding in the factory setting		Possible change	
11:# 9	No access to the coding addresses for the combustion controller parameters	11:9	Access open to the coding addresses for the combustion controller parameters.
25:1	With outside temperature sensor (automatic recognition)	25:0	Without outside temperature sensor (for constant temperature control units)
32:0	Without extension AM1	32:1	With extension AM1 (automatic recognition).
33:1	Function output A1 at extension AM1: Heating circuit pump	33:0	Function output A1: DHW circulation pump.
		33:2	Function output A1: Circulation pump for DHW tank heating.
34:0	Function output A2 at extension AM1: DHW circulation pump	34:1	Function output A2: Heating circuit pump.
		34:2	Function output A2: Circulation pump for DHW tank heating.
35:0	Without extension EA1	35:1	With extension EA1 (automatic recognition).
36:0	Function, output 157 at extension EA1: Fault message	36:1	Function output 157 : Feed pump.
		36:2	Function output 157 : DHW recirculation pump.

General *(continued)*

Coding in the factory setting		Possible change	
3A:0	Function input DE1 at extension EA1: Not assigned	3A:1	Function input DE1: Heating program - changeover.
		3A:2	Function input DE1: External demand with set supply temperature. Supply temperature setting: Coding address 9B. Internal circulation pump function: Coding address 3F.
		3A:3	Function input DE1: External blocking. Internal circulation pump function: Coding address 3E.
		3A:4	Function input DE1: External blocking with fault message input Internal circulation pump function: Coding address 3E.
		3A:5	Function input DE1: Fault message input.
		3A:6	Function input DE1: Brief operation, DHW circulation pump (pushbutton function DHW circulation pump runtime adjustment: Coding address 3D.
3B:0	Function input DE2 at extension EA1: Not assigned	3B:1	Function input DE2: Heating program - changeover.
		3B:2	Function input DE2: External demand with set supply temperature. Supply temperature setting: Coding address 9B. Internal circulation pump function: Coding address 3F.
		3B:3	Function input DE2: External blocking. Internal circulation pump function: Coding address 3E.
		3B:4	Function input DE2: External blocking with fault message input Internal circulation pump function: Coding address 3E.
		3B:5	Function input DE2: Fault message input.
		3B:6	Function input DE2: Brief operation, DHW circulation pump (pushbutton function). DHW circulation pump runtime adjustment: Coding address 3D.

General *(continued)*

Coding in the factory setting		Possible change	
3C:0	Function input DE3 at extension EA1: Not assigned	3C:1	Function input DE3: Heating program - changeover.
		3C:2	Function input DE3: External demand with set supply temperature. Supply temperature setting: Coding address 9B. Internal circulation pump function: Coding address 3F.
		3C:3	Function input DE3: External blocking. Internal circulation pump function: Coding address 3E.
		3C:4	Function input DE3: External blocking with fault message input Internal circulation pump function: Coding address 3E.
		3C:5	Function input DE3: Fault message input.
		3C:6	Function input DE3: Brief operation, DHW circulation pump (pushbutton function). DHW circulation pump runtime adjustment: Coding address 3D.
3D:5	DHW circulation pump runtime for brief operation: 5 minutes	3D:1 to 3D:60	DHW circulation pump runtime adjustable from 1 to 60 minutes.
3E:0	Internal circulation pump stays in control mode at signal "External blocking"	3E:1	Internal circulation pump stops at signal "External blocking".
		3E:2	Internal circulation pump starts at signal "External blocking".
3F:0	Internal circulation pump stays in control mode at signal "External demand"	3F:1	Internal circulation pump stops at signal "External demand".
		3F:2	Internal circulation pump starts at signal "External demand".

General *(continued)*

Coding in the factory setting		Possible change	
51:0	System with low loss header: Boiler circuit pump is always started when there is a heat demand	51:1	System with low loss header: When there is heat demand, the boiler circuit pump will only be started if the burner is running.
		51:2	System with heating water buffer DHW tank: When there is a heat demand, the internal circulation pump will only be started when the burner is operational.
52:0	Without supply temperature sensor for low loss header	52:1	With supply temperature sensor for low loss header (automatic recognition).
53:1	Function connection 28 of the internal extension: DHW circulation pump	53:0	Central fault message
		53:2	External heating circuit pump (heating circuit 1).
		53:3	External circulation pump for DHW tank heating.
54:0 DO NOT ADJUST	Without solar thermal system	54:1	With Vitosolic 100 (automatic recognition).
		54:2	With Vitosolic 200 (automatic recognition).
		54:3	With solar control module SM1 without auxiliary function (automatic recognition).
		54:4	With solar control module SM1 with auxiliary function, e.g. central heating backup (automatic recognition).
6E:50	No correction of measured outside temperature	6E:0 to 6E:100	Outside correction in 0.1 K steps 0 to 49 = -5 K to -0.1 K 51 to 100 = 0.1 K to 5 K
76:0	Without communication module	76:1	With LON communication module (recognized automatically).
		76:2	With cascade communication module (recognized automatically; only for constant temperature control units).

General *(continued)*

Coding in the factory setting		Possible change	
77:1	LON participant number	77:2 to 77:99	LON participant number, adjustable from 1 to 99: 1 = Boiler 10 - 98 = Vitotronic 200-H 99 = Vitocom Note: Allocate each number only once.
79:1	With LON communication module: Control unit is fault manager	79:0	Control unit is not fault manager.
7B:1	With LON communication module: Control unit transmits the time	7B:0	Does not transmit time.
7F:1	Detached house	7F:0	Apartment building Separate adjustment of holiday program and time program for DHW heating possible.
80:6	A fault message is displayed if a fault is active for at least 30 seconds	80:0	Immediate fault message.
		80:2 to 80:199	Minimum fault duration until fault message occurs, adjustable from 10 sec to 995 sec; 1 step Δ 5 sec.
81:1	Automatic summer/wintertime changeover	81:0	Manual summer/wintertime changeover.
		81:2	Use of the radio clock receiver (automatic recognition).
		81:3	With LON communication module: The control unit receives the time.
82:0	Operation with natural gas	82:1	Operation with LPG (only adjustable if coding address 11:9 has been set).
86:0 DO NOT ADJUST	--	--	--
87:0 DO NOT ADJUST	--	--	--
88:0	Temperature display in °C (Celsius)	88:1	Temperature display in °F (Fahrenheit).

General (continued)

Coding in the factory setting		Possible change	
8A:175	Do not adjust.	--	--
8F:0	Operation in the standard menu and extended menu enabled. Note: The respective code is only activated when you exit the service menu.	8F:1	Operation in standard menu and extended menu blocked. Emissions test mode can be enabled.
		8F:2	Operation enabled in the standard menu and blocked in the extended menu. Emissions test mode can be enabled.
90:128	Time constant for calculating the adjusted outside temperature 21.3 h	90:1 to 90:199	Fast (low values) or slow (high values) matching of the supply temperature, subject to the set value when the outside temperature changes; 1 step \pm 10 minutes.
93:0	0-5000 ft. (0-1525 m) Altitude operation	93:1 - 93:5	NOT USED
		93:6	5000-10000 ft. (1500 3000 m) Altitude operation
94:0	Without Open Therm extension	94:1	With Open Therm extension (automatic recognition).
95:0	Without Vitocom 100 communication interface	95:1	With Vitocom 100 communication interface (automatic recognition).
97:0	With LON communication module: The outside temperature of the sensor connected to the control unit is utilized internally	97:1	Control unit receives outside temperature.
		97:2	Control unit transmits the outside temperature to the Vitotronic 200-H.
98:1	With LON communication module: Viessmann system number (in conjunction with monitoring several systems via Vitocom 300)	98:1 to 98:5	System number adjustable from 1 to 5.
99:0 DO NOT ADJUST	--	--	--
9A:0 DO NOT ADJUST	--	--	--
9B:70	Set supply temperature for external demand 158° F (70° C)	9B:0 to 9B:127	Set supply temperature for external demand adjustable from 32 to 260° F (0 to 127° C) (limited by boiler-specific parameters).
9C:20	Monitoring LON participants. If a participant fails to respond, the values specified inside the control unit will be used after 20 minutes. Only then will a fault message be issued.	9C:0	No monitoring
		9C:5 to 9C:60	Time adjustable from 5 to 60 minutes.
9F:8	Differential temperature 8 K; only in conjunction with mixing valve circuit	9F:0 to 9F:40	Differential temperature adjustable from 0 to 40 K.

Boiler

Select "Boiler"

Coding

Coding in the factory setting		Possible change	
01:1 DO NOT ADJUST	Single boiler system	--	--
04:1	Minimum burner pause subject to the boiler load (specified by boiler coding card)	04:0	System with low-loss header. Minimum burner pause set permanently (specified by boiler coding card).
06:...	Maximum limit of the boiler water temperature, specified in °C by the boiler coding card	06:20 to 06:127	Maximum limit of the boiler water temperature within the ranges specified by the boiler.
0D:0 DO NOT ADJUST	--	--	--
0E:0 DO NOT ADJUST	--	--	--
13:1 DO NOT ADJUST	--	--	--
14:1 DO NOT ADJUST	--	--	--
15:1 DO NOT ADJUST	--	--	--
21:0	No service interval (hours run) selected	21:1 to 21:100	Number of hours run before the burner should be serviced is adjustable from 100 to 10,000 h One adjusting step \pm 100 h.
23:0	No time interval for burner service	23:1 to 23:24	Interval adjustable from 1 to 24 months.
24:0	No "Service" display	24:1	"Service" display (the address is automatically set and must be manually reset after a service has been carried out).
28:0	No burner interval ignition	28:1 to 28:24	Interval adjustable from 1 h to 24 h. The burner is force started once every 30 sec (only when operating with LPG).
2D:0 DO NOT ADJUST	--	--	--
2E:0 DO NOT ADJUST	--	--	--
2F:0	Venting program/fill program disabled	2F:1	Venting program enabled.
		2F:2	Fill program enabled.
30:0 DO NOT ADJUST	Internal circulation pump without variable speed (e.g. temporarily for service).	30:1	Internal variable speed circulation pump (automatic adjustment)
31:... DO NOT ADJUST	Set speed in % of the internal circulation pump when operated as boiler circuit pump, specified by the boiler coding card	31:0 to 31:100	Set speed adjustable from 0 to 100%.
38:0	Status burner control unit: Operational (no fault)	38: \neq 0	Status burner control unit: Fault.

DHW

Select "DHW"

Coding

Coding in the factory setting		Possible change	
56:0	Set DHW temperature adjustable from 50 to 140° F (10 to 60° C)	56:1	Set DHW temperature adjustable from 50 to over 140° F (10 to over 60° C). Note: Maximum value subject to boiler coding card. Observe the maximum permissible DHW temperature.
58:0	Without auxiliary function for DHW heating	58:10 to 58:60	Input of a second set DHW temperature, adjustable from 50 to 140° F (10 to 60° C) (observe coding addresses "56" and "63").
59:0	DHW tank heating: Starting point -2.5 K Stopping point +2.5 K	59:1 to 59:10	Starting point adjustable from 1 to 10 K below the set value.
5E:0 DO NOT ADJUST	Circulation pump for DHW tank heating stays in control mode at signal "External blocking"	5E:1	Circulation pump for DHW tank heating stops at signal "External blocking".
		5E:2	Circulation pump for DHW tank heating starts at signal "External blocking".
5F:0 DO NOT ADJUST	Circulation pump for DHW tank heating stays in control mode at signal "External demand"	5F:1	Circulation pump for DHW tank heating stops at signal "External demand".
		5F:2	Circulation pump for DHW tank heating starts at signal "External demand".
60:20	During DHW heating, the boiler water temperature is maximum 20 K higher than the set DHW temperature	60:5 to 60:25	The differential between the boiler water temperature and the set DHW temperature is adjustable from 5 to 25 K.
62:2	Circulation pump with 2 minutes run-on time after DHW tank heating	62:0	Circulation pump without run-on.
		62:1 to 62:15	Run-on time adjustable from 1 to 15 minutes.

DHW *(continued)*

Coding in the factory setting		Possible change	
63:0 (NOT USED)	Without auxiliary function for DHW heating	63:1	Auxiliary function: 1 x daily
		63:2 to 63:14	Every 2 days to every 14 days.
		63:15	2 x daily
65:0 DO NOT ADJUST	Information regarding the type of diverter valve (not adjustable): 0: No diverter valve 1: Viessmann diverter valve 2: Wilo diverter valve 3: Grundfos diverter valve	--	--
6C:100 NOT USED	Set speed, internal circulation pump with DHW heating 100%	6C:0 to 6C:100	Set speed adjustable from 0 to 100%.
6F:...	Maximum output for DHW heating in %, specified by the boiler coding card	6F:0 to 6F:100	Maximum output for DHW heating adjustable from minimum output to 100%.
71:0	DHW circulation pump: "ON" in accordance with the time program	71:1	"OFF" during DHW heating to first set value.
		71:2	"ON" during DHW heating to first set value.
72:0	DHW circulation pump: "ON" in accordance with the time program	72:1	"OFF" during DHW heating to second set value.
		72:2	"ON" during DHW heating to second set value.
73:0	DHW circulation pump: "ON" in accordance with the time program	73:1 to 73:6	"ON" from once per hour for 5 minutes up to 6 times per hour for 5 minutes during the time program.
		73:7	Constantly "ON".

Heating Circuit 1, 2 and 3

Select "Heating circuit ..."

Coding

Coding in the factory setting		Possible change	
A0:0	Without remote control	A0:1	With Vitotrol 200A (automatic recognition).
		A0:2	With Vitotrol 300A or Vitohome 300 (automatic recognition).
A1:0	All possible settings at the remote control can be accessed	A1:1	Only party mode can be set at the remote control (only for Vitotrol 200A).
A3:2	Outside temperature below 34° F (1° C): Heating circuit pump "ON" Outside temperature above 37° F (3° C): Heating circuit pump "OFF"	A3:9 to A3:15	Heating circuit pump "ON/OFF" (see following table).

Note: When selecting a value below 33.8° F (1° C), there is a risk of pipes outside the thermal envelope of the building freezing up. The standby mode in particular should be taken into consideration, e.g. during holidays.

Parameter address A3:...	Heating circuit pump	
	"ON"	"OFF"
-9	14° F (-10° C)	17.6° F (-8° C)
-8	15.8° F (-9° C)	19.4° F (-7° C)
-7	17.6° F (-8° C)	21.2° F (-6° C)
-6	19.4° F (-7° C)	23° F (-5° C)
-5	21.2° F (-6° C)	24.8° F (-4° C)
-4	23° F (-5° C)	26.6° F (-3° C)
-3	24.8° F (-4° C)	28.4° F (-2° C)
-2	26.6° F (-3° C)	32.2° F (-1° C)
-1	28.4° F (-2° C)	32° F (0° C)
0	32.2° F (-1° C)	33.8° F (1° C)
1	32° F (0° C)	35.6° F (2° C)
2 to 15	33.8 to 57.2° F (1 to 14° C)	37.4 to 60.8° F (3 to 16° C)

Heating Circuit 1, 2 and 3 *(continued)*

Coding in the factory setting		Possible change	
A4:0	With frost protection	A4:1	No frost protection; this setting is only possible if code "A3:9" has been selected. Note: "Important" observe for code "A3".
A5:5	With heating circuit pump logic function (economy mode): Heating circuit pump "OFF" when the outside temperature (AT) is 1 K higher than the set room temperature (RTset) $AT > RTset + 1 K$	A5:0	Without heating circuit pump logic function.
		A5:1 to A5:15	With heating circuit pump logic function: Heating circuit pump "OFF"; see following table.

Parameter address A5:...	With heating circuit pump logic function: Heating circuit pump "OFF"
1	$AT > RTset + 5 K$
2	$AT > RTset + 4 K$
3	$AT > RTset + 3 K$
4	$AT > RTset + 2 K$
5	$AT > RTset + 1 K$
6	$AT > RTset$
7	$AT > RTset - 1 K$
to 15	$AT > RTset - 9 K$

Coding in the factory setting		Possible change	
A6:36	Extended economy function disabled	A6:5 to A6:35	Extended economy function enabled, i.e. the burner and heating circuit pump will stop and the mixing valve close at a variable value, adjustable between 41 and 95° F (5 and 35° C) plus 1.8° F (1° C). The base value is the adjusted outside temperature. This value is based on the actual outside temperature and a time constant, which takes the cooling down of an average building into consideration.
A7:0	Without mixing valve economy function	A7:1	With mixing valve economy function (extended heating circuit pump logic): Heating circuit pump also "OFF": - If the mixing valve has been attempting to close for longer than 20 minutes. - Heating circuit pump "ON": If the mixing valve changes to control function. - If there is a risk of frost.

Heating Circuit 1, 2 and 3 *(continued)*

Coding in the factory setting		Possible change	
A8:1	Heating circuit with mixing valve creates a demand for the boiler circuit pump	A8:0	Heating circuit with mixing valve creates no demand for the boiler circuit pump.
A9:7	With pump idle time: Heating circuit pump "OFF" if the set value is altered through a change in operating mode or through a change in the set room temperature	A9:0	Without pump idle time.
		A9:1 to A9:15	With pump idle time, adjustable from 1 to 15.
B0:0	With remote control: Heating mode/reduced mode: (only change the code for the heating circuit with mixing valve)	B0:1	Heating mode: weather compensated. Reduced mode: with room temperature hook-up.
		B0:2	Heating mode: with room temperature hook-up. Reduced mode: weather-compensated.
		B0:3	Heating mode/reduced mode: with room temperature hook-up.
B2:8	With remote control unit and for the heating circuit, operation with room temperature hook-up must be programmed: Room influence factor 8 (change the code only for the heating circuit with mixing valve)	B2:0	Without room influence.
		B2:1 to B2:64	Room influence factor adjustable from 1 to 64.
B5:0	With remote control: No room temperature-dependent heating circuit pump logic function (only change the code for the heating circuit with mixing valve)	B5:1 to B5:8	Heating circuit pump logic function, see the following table:

Parameter address B5:...	With heating circuit pump logic function:	
	Heating circuit pump "OFF"	Heating circuit pump "ON"
1	$RT_{actual} > RT_{set} + 5\text{ K}$	$RT_{actual} < RT_{set} + 4\text{ K}$
2	$RT_{actual} > RT_{set} + 4\text{ K}$	$RT_{actual} < RT_{set} + 3\text{ K}$
3	$RT_{actual} > RT_{set} + 3\text{ K}$	$RT_{actual} < RT_{set} + 2\text{ K}$
4	$RT_{actual} > RT_{set} + 2\text{ K}$	$RT_{actual} < RT_{set} + 1\text{ K}$
5	$RT_{actual} > RT_{set} + 1\text{ K}$	$RT_{actual} < RT_{set}$
6	$RT_{actual} > RT_{set}$	$RT_{actual} < RT_{set} - 1\text{ K}$
7	$RT_{actual} > RT_{set} - 1\text{ K}$	$RT_{actual} < RT_{set} - 2\text{ K}$
8	$RT_{actual} > RT_{set} - 2\text{ K}$	$RT_{actual} < RT_{set} - 3\text{ K}$

Heating Circuit 1, 2 and 3 *(continued)*

Coding in the factory setting		Possible change	
C5:20	Electronic minimum flow temperature limit 68° F (20° C)	C5:1 to C5:127	Minimum limit adjustable from 1 to 260° F (127° C) (limited by boiler-specific parameters).
C6:74	Electronic maximum flow temperature limit 165° F (74° C)	C6:10 to C6:127	Maximum limit adjustable from 50 to 260° F (10 to 127° C) (limited by boiler-specific parameters).
D3:14	Heating curve slope = 1.4	D3:2 to D3:35	Heating curve slope adjustable from 0.2 to 3.5 (see page 38).
D4:0	Heating curve shift = 0	D4:-13 to D4:40	Heating curve shift adjustable from -13 to 40 (see page 38).
D5:0	The external heating program changeover changes the heating program to "Constant operation with reduced room temperature" or "Standby mode"	D5:1	The external heating program changeover changes to "Constant operation with standard room temperature" (subject to coding address 3A, 3B and 3C).
D6:0	Heating circuit pump stays in control mode at signal "External blocking"	D6:1	Heating circuit pump stops at signal "External blocking" (subject to coding addresses 3A, 3B and 3C).
		D6:2	Heating circuit pump starts at signal "External blocking" (subject to coding addresses 3A, 3B and 3C).
D7:0	Heating circuit pump stays in control mode at signal "External demand"	D7:1	Heating circuit pump stops at signal "External demand" (subject to coding addresses 3A, 3B and 3C).
		D7:2	Heating circuit pump starts at signal "External demand" (subject to coding addresses 3A, 3B and 3C).
D8:0	No heating program changeover via extension EA1	D8:1	Heating program changeover via input DE1 at extension EA1.
		D8:2	Heating program changeover via input DE2 at extension EA1.
		D8:3	Heating program changeover via input DE3 at extension EA1.
E1:1 DO NOT ADJUST	--	--	--
E2:50	With remote control: No display correction for the actual room temperature	E2:0 to E2:49	Display correction -5 K to Display correction -0.1 K.
		E2:51 to E2:99	Display correction +0.1 K to Display correction +4.9 K.

Heating Circuit 1, 2 and 3 (continued)

Coding in the factory setting		Possible change	
E5:0	Without external variable speed heating circuit pump	E5:1	With external variable speed heating circuit pump (automatic recognition).
E6:... DO NOT ADJUST	Maximum speed of the variable speed heating circuit pump in % of the maximum speed in standard mode. Value is specified by boiler-specific parameters.	E6:0 to E6:100	Maximum speed adjustable from 0 to 100%.
E7:30 DO NOT ADJUST	Minimum speed of the variable speed heating circuit pump: 30% of the maximum speed.	E7:0 to E7:100	Minimum speed adjustable from 0 to 100% of the maximum speed.
E8:1	Minimum speed in operation with reduced room temperature subject to the setting in coding address "E9"	E8:0	Speed subject to the setting in coding address "E7".
E9:45	Speed of the variable speed heating circuit pump: 45% of the maximum speed during operation with reduced room temperature	E9:0 to E9:100	Speed adjustable from 0 to 100% of the maximum speed during operation with reduced room temperature.
F1:0 NOT USED	Slab curing function disabled	F1:1 to F1:6 F1:15	-- --
F2:8	Time limit for party mode or external heating program changeover via pushbutton: 8 h*1	F2:0 F2:1 to F2:12	No time limit for party mode*1. Time limit adjustable from 1 to 12 h *1.
F5:12	Run-on time of the boiler circuit pump in heating mode: 12 minutes.	F5:0 F5:1 to F5:20	No run-on time for the circulation pump in the heating circuit connection set. Run-on time of the circulation pump in the heating circuit connection set adjustable from 1 to 20 minutes.

*1 Party mode ends automatically in the "Heating and DHW" program, when the system changes over to operation with standard room temperature.

Heating Circuit 1, 2 and 3 *(continued)*

Coding in the factory setting		Possible change	
F6:25	In the "Only DHW" operating mode, the circulation pump in the heating circuit connection set is permanently ON	F6:0	In the "Only DHW" operating mode, the circulation pump in the heating circuit connection set is permanently off.
		F6:1 to F6:24	In the "Only DHW" operating mode, the circulation pump in the heating circuit connection set will be started 1 to 24 times per day for 10 minutes each time.
F7:25	In the "Standby" operating mode, the internal circulation pump is permanently ON	F7:0	In the "Standby" operating mode, the internal circulation pump is permanently off.
		F7:1 to F7:24	In the "Standby" operating mode, the internal circulation pump will be started 1 to 24 times per day for 10 minutes each time.
F8:-5	Temperature limit for terminating the reduced mode 23° F (-5° C); See operating instructions. Observe the setting of coding address "A3".	F8: + 10 to F8:-60	Temperature limit adjustable from 50 to -76° F (10 to -60° C).
		F8:-61	Function disabled.
F9:-14	Temperature limit for raising the reduced set room temperature 6.8° F (-14° C); See operating instructions.	F9: + 10 to F9:-60	Temperature limit for raising the set room temperature to the value selected for standard mode adjustable from 50 to -76° F (10 to -60° C).
FA:20	Raising the set boiler water temperature or the set flow temperature when changing from operation with reduced room temperature to operation with standard room temperature, by 20%. See operating instructions.	FA:0 to FA:50	Temperature rise adjustable from 0 to 50%.
FB:60	Duration for raising the set boiler water temperature or the set flow temperature (see coding address "FA") 60 minutes. See operating instructions.	FB:0 to FB:300	Duration adjustable from 0 to 300 minutes; 1 step Δ 2 minutes.

Calling up the Service Level

Press OK and  simultaneously for approximately 4 seconds

Note: Do not adjust menu item "Multi-boiler system". The menu item turns a weather-compensated control unit into a constant temperature control unit.

Service menu overview

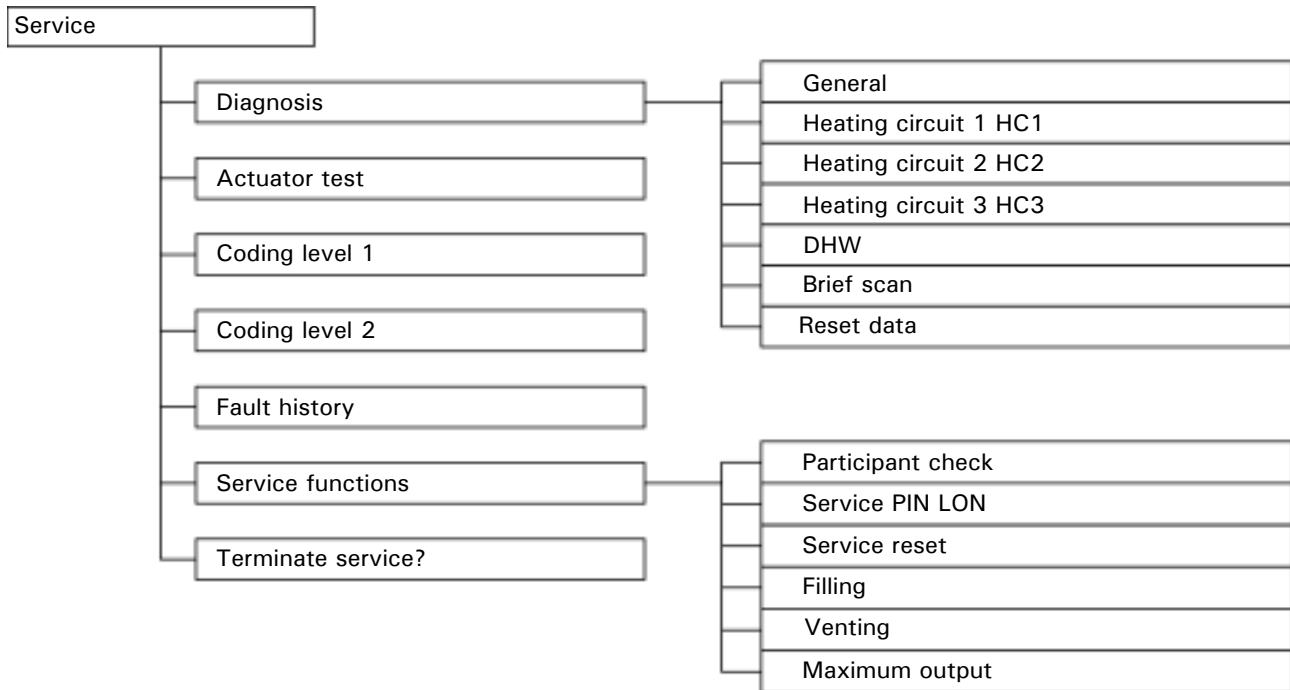

Exiting the service level

1. Select "Terminate service?".
2. Select "Yes".
3. Confirm with OK.

Note: The service level is automatically exited after 30 minutes.

Diagnosis

Scanning operating data

- Operating data can be scanned in six areas.
See "Diagnosis" in the service menu overview.
Operating data on heating circuits with mixing valves and solar can only be scanned if the components are installed in the system. For further information on operating data, see chapter "Brief scan".

Note: "- -" appears on the display if a sensor that has been scanned is faulty.

Calling up operating data

1. Press OK and  simultaneously for approximately 4 seconds.
2. "Diagnosis"
3. Select required group, e.g. "General"



Refer to Operating instructions

Brief scan

In the brief scan, you can call up temperatures, software versions and connected components, for example:

1. Press OK and  simultaneously for approximately 4 seconds
2. "Diagnosis"
3. "Brief scan".
4. Press OK. The display shows 9 lines with 6 fields each.

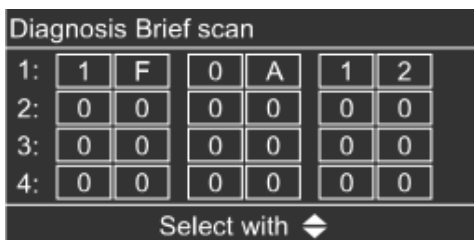

Resetting operating data

Saved operating data (e.g. hours run) can be reset to 0. The value "Adjusted outside temp" is reset to the actual value.

1. Press OK and  simultaneously for approximately 4 seconds
2. "Diagnosis"
3. "Reset data"
4. Select required value (e.g. "Burner starts") or "All details".

The following values can be scanned, depending on the system installed:

Display screen	Explanation
Slope A1*1 - shift A1	
Slope M2*2 - shift M2	
Outdoor temperature adjustment	The adjusted outdoor temperature can be reset to the actual outdoor temperature with "⌘".
Outdoor temperature actual	
Boiler temperature setpoint	
Boiler temperature actual	
DHW temperature setpoint	
DHW temperature actual	Heating circuit with mixing valve.
Supply temperature	Heating circuit with mixing valve.
Supply temperature actual	Low-loss header.
Common supply temperature setpoint	Low-loss header.
Common supply temperature actual	
Boiler coding card	
Brief scan 1 to 8	

Diagnosis *(continued)*



For an explanation of the relevant values in the individual lines and fields, see the following table:

Line (brief scan)	Field					
	1	2	3	4	5	6
1:	Software version Control unit		Equipment version		Burner control unit version	
2:	System scheme 01 to 10		Number of KM BUS participants	Maximum demand temperature		
3:	0	Software version Programming unit	Software version, Mixer extension 0: No mixing valve extension	0	Software version, LON module	0
4:	Software version Burner control unit		Type Burner control unit		Appliance type	
5:	0	0		0	0	0
6:	Number of LON participants		Check digit	Max. output Details in %		
7:	Heating circuit A1 (without mixer) Remote control 0: without 1: Vitotrol 200A 2: Vitotrol 300A or Vitohome		Heating circuit M2 (with mixer) Remote control 0: without 1: Vitotrol 200A 2: Vitotrol 300A or Vitohome		Heating circuit M3 (with mixer) Remote control 0: without 1: Vitotrol 200A 2: Vitotrol 300A or Vitohome	
8:	Internal circulation pump Variable speed pump 0: without 1: Wilo 2: Grundfos		Heating circuit pump, heating circuit M2 Variable speed pump 0: without 1: Wilo 2: Grundfos		Heating circuit pump, heating circuit M3 Variable speed pump 0: without 1: Wilo 2: Grundfos	
9:	Internal details for calibration				Software version Extension AM1	Software version, Extension EA1

Checking Outputs (relay tests)

1. Press OK and  simultaneously for approximately 4 seconds
2. "Actuator test"

The following relay outputs can be controlled subject to system design:

Display		Explanation
All actuators off		All actuators are off
Base load	On	Burner operated at minimum output; internal circulation pump is started.
Full load	On	Burner operated at maximum output; internal circulation pump is started.
Output, internal	On	Output  active (boiler internal pump).
Valve	Heating	Diverter valve set to heating mode.
Valve	Center	Diverter valve in central position (filling/draining).
Valve	DHW	Diverter valve set to DHW mode.
Htg circ pump HC2	On	Heating circuit pump output enabled (extension to heating circuit with mixing valve).
Mixing valve HC2	Open	"Mixing valve open" output enabled (extension to heating circuit with mixing valve).
Mixing valve HC2	Close	"Mixing valve close" output enabled (extension to heating circuit with mixing valve).
Htg circ pump HC3	On	Heating circuit pump output enabled (extension to heating circuit with mixing valve).
Mixing valve HC3	Open	"Mixing valve open" output enabled (extension to heating circuit with mixing valve).
Mixing valve HC3	Close	"Mixing valve close" output enabled (extension to heating circuit with mixing valve).
Outp. int. exten. H1	On	Output at internal extension enabled.
AM1 output 1	On	Output A1 at extension AM1 enabled.
AM1 output 2	On	Output A2 at extension AM1 enabled.
EA1 output 1	On	Contact P - S at plug  of extension EA1 closed.
Output 21	On	DHW circulation pump (internal pump)
EA1 output 1	On	Heating circuit A1 (programmable pump output)

Fault Codes

In the event of a fault, red fault indicator (A) flashes. "▲" flashes on the display and "Fault" is shown.

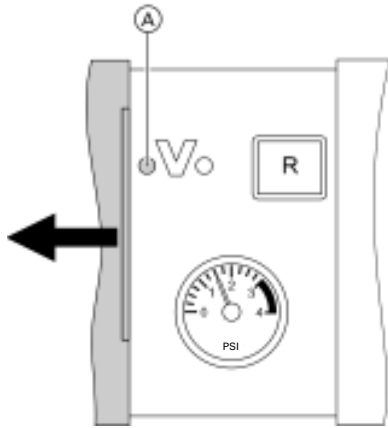

The fault code is displayed with OK. For an explanation of the fault code, see the following pages. For some faults, the type of fault is also displayed in plain text.

Acknowledging a fault

Follow the instructions on the display.

Note: The fault message is transferred to the standard menu. A fault message facility, if connected, will be switched OFF. If an acknowledged fault is not remedied, the fault message will be re-displayed the following day and the fault message facility restarted.

Calling up acknowledged faults

Select "Fault" in the standard menu.

The current faults will be displayed in a list.

Calling up fault codes from the fault memory (fault history)

The 10 most recent faults (including resolved ones) are saved and can be called up.

Faults are sorted by date.

1. Press OK and simultaneously for approximately 4 seconds
2. "Fault history"
3. "Display?"

Fault code on display	System behavior *1	Cause	Corrective action
OF	Control mode	Code "OF" is only displayed in the fault history	Service required Note: After servicing select code "24:0"
10	Boiler operates based on outdoor temperature of 32° F (0° C)	Short circuit on outdoor temperature sensor	Check the outdoor temperature sensor (see page 78).
18	Boiler operates based on outdoor temperature of 32° F (0° C)	Outdoor temperature sensor cable broken	Check the outdoor temperature sensor (see page 78).
20	Regulates without supply temperature sensor (low-loss header)	Short circuit on system supply temperature sensor	Check the low-loss header sensor (see page 79).
28	Regulates without supply temperature sensor (low-loss header)	System supply temperature sensor cable broken	Check the low-loss header sensor (see page 79). If no low loss header sensor is connected, set code 52:0.
30	Burner blocked	Short circuit on boiler water temperature sensor	Check the boiler water temperature sensor (see page 79).
38	Burner blocked	Boiler water temperature sensor cable broken	Check the boiler water temperature sensor (see page 79).

*1 Control mode: Boiler/burner fully operational (fault code must be verified and reset).
 Burner in fault mode: Boiler control requires manual reset before burner can resume operation.
 Burner blocked: If fault cause is corrected, burner resumes operation.

Fault Codes *(continued)*

Fault code on display	System behavior *1	Cause	Corrective action
40	Mixing valve closes	Heating circuit 2 with mixing valve supply short circuit on temperature sensor	Check the supply temperature sensor (see page 79).
44	Mixing valve closes	Short circuit, supply temperature sensor, heating circuit 3 (with mixing valve)	Check supply temperature sensor (see page 79).
48	Mixing valve closes	Heating circuit 2 with mixing valve supply temperature sensor cable broken	Check the supply temperature sensor (see page 79).
4C	Mixing valve closes	Supply temperature sensor cable broken circuit 3 (with mixing valve)	Check supply temperature sensor (see page 79).
50	No DHW heating	Short circuit on DHW tank temperature sensor	Check the DHW sensor (see page 78).
51	No DHW heating	Short circuit on outlet temperature sensor	Check the sensor (see page 78)
58	No DHW heating	Tank temperature sensor cable broken	Check the sensor (see page 78).
59	No DHW heating	Outlet temperature sensor cable broken	Check the sensor (see page 78)
A3	Burner blocked	Flue gas temperature sensor not properly positioned	Properly install flue gas temperature sensor.
A7	Control mode (stays in factory default setting)	Faulty programming unit	Replace the programming unit.
A8	Burner blocked. The venting program is started automatically (see page 14)	Air lock in the internal circulation pump or minimum flow rate not achieved	Vent the system if the fault message continues to be displayed
A9	The burner operates at its lower output if a heating circuit with mixing valve is connected. The burner is blocked if only one heating circuit without mixing valve is connected.	Internal circulation pump blocked	Check the circulation pump

*1 Control mode: Boiler/burner fully operational (fault code must be verified and reset).
 Burner in fault mode: Boiler control requires manual reset before burner can resume operation.
 Burner blocked: If fault cause is corrected, burner resumes operation.

Fault Codes *(continued)*

Fault code on display	System behavior *1	Cause	Corrective action
B0	Burner blocked	Flue gas temperature sensor shorted out	Check flue gas temperature sensor (see page 80).
B1	Control mode (stays in factory default setting)	Communication fault; programming unit (internal)	Check connections and replace programming unit if required.
B5	Control mode (factory default setting)	Internal fault	Replace the control unit.
B7	Burner blocked	Boiler coding card missing, faulty or incorrect boiler coding card	Plug in boiler coding card or replace if faulty.
B8	Burner blocked	Flue gas temperature sensor cable broken	Check flue gas temperature sensor (see page 80).
BA	Mixing valve regulates to a supply temperature of 68° F (20° C)	Communication fault - accessory kit for heating circuit 2 with mixing valve	Check extension kit connections and code.
BB	Mixing valve regulates to a supply temperature of 68° F (20° C)	Communication error, extension kit for heating circuit 3 (with mixing valve)	Check extension kit connections and code.
BC	Control mode without remote control	Communication error, remote control Vitotrol heating circuit 1 (without mixing valve)	Check connections, cable, coding address "A0" in "Heating circuit" group and remote control unit setting.
BD	Control mode without remote control	Communication error, remote control Vitotrol heating circuit 2 (with mixing valve)	Check connections, cable, coding address "A0" in "Heating circuit" group and remote control unit setting. For wireless remote control units: Check radio path connections, place remote control unit and wireless repeater close to the boiler. Check KM BUS connection to wireless base station. Replace wireless components.

*1 Control mode: Boiler/burner fully operational (fault code must be verified and reset).
 Burner in fault mode: Boiler control requires manual reset before burner can resume operation.
 Burner blocked: If fault cause is corrected, burner resumes operation.

Fault Codes *(continued)*

Fault code on display	System behavior *1	Cause	Corrective action
BE	Control mode without remote control	Communication error, remote control Vitotrol heating circuit 3 (with mixing valve)	Check connections, cable, coding address "A0" in "Heating circuit" group and remote control unit setting. For wireless remote control units: Check radio path connections, place remote control unit and wireless repeater close to the boiler. Check KM BUS connection to wireless base station. Replace wireless components.
BF	Control mode	Incorrect LON communication module	Replace LON communication module.
C1	Control mode	Communication fault extension EA1	Check connections. Without extension EA1, set code "5B:0"
C3	Control mode	Extension AM1 communication fault	Check connections. Without extension EA1, set code "32:0"
C4	Control mode	Communication fault, Open Therm extension	Check Open Therm extension.
C5	Control mode, max. pump speed	Communication error, variable speed internal pump	Check setting of coding address "30"
CD NOT USED	Control mode	Communication fault, Vitocom 100 (KM-BUS)	Check connections Vitocom 100 coding address "95"
CF	Control mode	Communication fault - LON communication module	Replace LON communication module.
D6	Control mode	Input DE1 reports a fault at extension EA1	Remove fault at appliance concerned.
D7	Control mode	Input DE2 reports a fault at extension EA1	Remove fault at appliance concerned.

*1 Control mode: Boiler/burner fully operational (fault code must be verified and reset).
 Burner in fault mode: Boiler control requires manual reset before burner can resume operation.
 Burner blocked: If fault cause is corrected, burner resumes operation.

Fault Codes *(continued)*

Fault code on display	System behavior *1	Cause	Corrective action
D8	Control mode	Input DE3 reports a fault at extension EA1	Remove fault at appliance concerned.
DA	Control mode without room influence	Short circuit on room temperature sensor, heating circuit 1 without mixing valve	Check the room temperature sensor, heating circuit 1 without mixing valve.
DB	Control mode without room influence	Room temperature sensor, shorted out heating circuit 2 with mixing valve	Check the room temperature sensor, heating circuit 2.
DC	Control mode without room influence	Short circuit, room temperature sensor, heating circuit 3 (with mixing valve)	Check room temperature sensor, heating circuit 3
DD	Control mode without room influence	Room temperature sensor cable broken, heating circuit 1 without mixing valve	Check the room temperature sensor, heating circuit 1 and the remote control setting (see page 79).
DE	Control mode without room influence	Room temperature sensor cable broken, heating circuit 2 with mixing valve	Check the room temperature sensor, heating circuit 2 and the remote control settings (see page 79).
DF	Control mode without room influence	Room temperature sensor cable broken, heating circuit 3 (with mixing valve)	Check room temperature sensor for heating circuit 3 and remote control settings (see page 79).
E0	Control mode	Fault external LON participant	Check connections and LON participants.
E1	Burner in a fault mode	Ionization current too high during calibration	Check gap between ionization electrode and burner gauze assembly (see page 21). In open flue mode, prevent very dusty conditions for the combustion air. Press reset button R .
E3	Burner in a fault mode	Heat transfer too low during calibration. Temperature limiter caused shutdown.	Ensure adequate heat transfer. Press reset button R .

- *1 Control mode: Boiler/burner fully operational (fault code must be verified and reset).
 Burner in fault mode: Boiler control requires manual reset before burner can resume operation.
 Burner blocked: If fault cause is corrected, burner resumes operation.

Fault Codes *(continued)*

Fault code on display	System behavior *1	Cause	Corrective action
E4	Burner blocked	Fault, supply voltage 24 V	Replace the control unit.
E5	Burner blocked	Fault flame amplifier	Replace control unit.
E7	Burner in a fault mode	Ionization current too low during calibration	Check ionization electrode: - Distance to burner gauze assembly (see page 21). - Contamination of electrode. - Connecting lead and plug-in connections. Check flue system; remedy flue gas recirculation if required. Press reset button R .
E8	Burner in a fault mode	The ionization current lies outside the permissible range	Check gas supply (gas pressure and gas flow limiter), gas train and connecting lead. Check allocation of gas type (see page 15). Check ionization electrode: - Distance to burner gauze assembly (see page 21). - Contamination of electrode Press reset button R .
EA	Burner in a fault mode	The ionization current lies outside the permissible range during calibration (deviation from previous level too great)	Check flue system; remedy flue gas recirculation if required In open flue mode, prevent very dusty conditions for the combustion air. Press reset button R . Following several unsuccessful reset attempts, replace boiler coding card and press reset button R .
EB	Burner in a fault mode	Repeated flame loss during calibration	Check gap between ionization electrode and burner gauze assembly (see page 21). Check allocation of gas type (see page 15). Check flue system; remedy flue gas recirculation if required. Press reset button R .
EC	Burner in a fault mode	Parameter fault during calibration	Press reset button R or Replace boiler coding card and press reset button R .
ED	Burner in a fault mode	Internal fault	Replace control unit.

*1 Control mode: Boiler/burner fully operational (fault code must be verified and reset).
 Burner in fault mode: Boiler control requires manual reset before burner can resume operation.
 Burner blocked: If fault cause is corrected, burner resumes operation.

Fault Codes *(continued)*

Fault code on display	System behavior *1	Cause	Corrective action
EE	Burner in a fault mode	At burner start, flame signal is missing or too weak	Check gas supply (gas pressure and gas regulator). Check gas train. Check ionization electrode and connecting cable. Check ignition: - Connecting leads to ignition module and ignition electrode. - Ignition electrode gap and contamination (see page 21). Check condensate drain. Press reset button R .
EF	Burner in a fault mode	Flame is lost immediately after it has built (during the safety time)	Check gas supply (gas pressure and gas regulator). Check flue gas/ventilation air system for flue gas recirculation. Check ionization electrode (replace if required): - Distance to burner gauze assembly (see page 21). - Contamination of electrode Press reset button R .
F0	Burner blocked	Internal fault	Replace the control unit.
F1	Burner in a fault mode	Maximum flue gas temperature exceeded 230° F (110° C) limit.	Check heating system fill level. Bleed air from system. Check circulation pump. Check boiler water temperature sensor and cable. Press reset button R after vent system has cooled down.
F2	Burner in fault mode	Fixed high limit switch open (activated)	Check heating system fill level. Check the circulation pump. Bleed air from the system. Check fixed high limit switch and connecting cables. Press reset button R .
F3	Burner in fault mode	Flame signal already present at burner start	Check the ionization electrode and connecting cable. Press reset button R .
F8	Burner in fault mode	Gas valve closes too late	Check the gas valve. Check both control wiring/connections. Press reset button R .
F9	Burner in fault mode	Fan speed too low during burner start	Check the fan, the fan cables and power supply. Check the fan control. Press reset button R .

- *1 Control mode: Boiler/burner fully operational (fault code must be verified and reset).
 Burner in fault mode: Boiler control requires manual reset before burner can resume operation.
 Burner blocked: If fault cause is corrected, burner resumes operation.

Fault Codes *(continued)*

Fault code on display	System behavior *1	Cause	Corrective action
FA	Burner in fault mode	Fan not at standstill	Check the fan, the fan connecting cables and fan control. Check the fan control. Press reset button R .
FC	Burner in fault mode	Gas valve faulty or faulty modulation valve control; or vent system blocked	Check the gas valve. Check the vent system. Press reset button R .
FD	Burner in a fault state and additional fault B7 is displayed	Boiler coding card is missing	Insert the boiler coding card. Press reset button R . Replace control unit if fault persists.
	Burner in a fault state	Fault, burner control unit	Check ignition electrodes and connecting cables. Check whether a strong interference (EMC) field exists near the appliance. Press reset button R . Replace control unit if fault persists.
FE	Burner in fault mode	Damaged or incorrect boiler coding card or main PCB	Press reset button R . If the fault persists, check the boiler coding card or replace it or the control unit.
FF	Burner in fault mode	Internal fault or reset button R blocked	Restart the equipment. Replace the control unit if the equipment will not restart.

*1 Control mode: Boiler/burner fully operational (fault code must be verified and reset).
 Burner in fault mode: Boiler control requires manual reset before burner can resume operation.
 Burner blocked: If fault cause is corrected, burner resumes operation.

Corrective Action

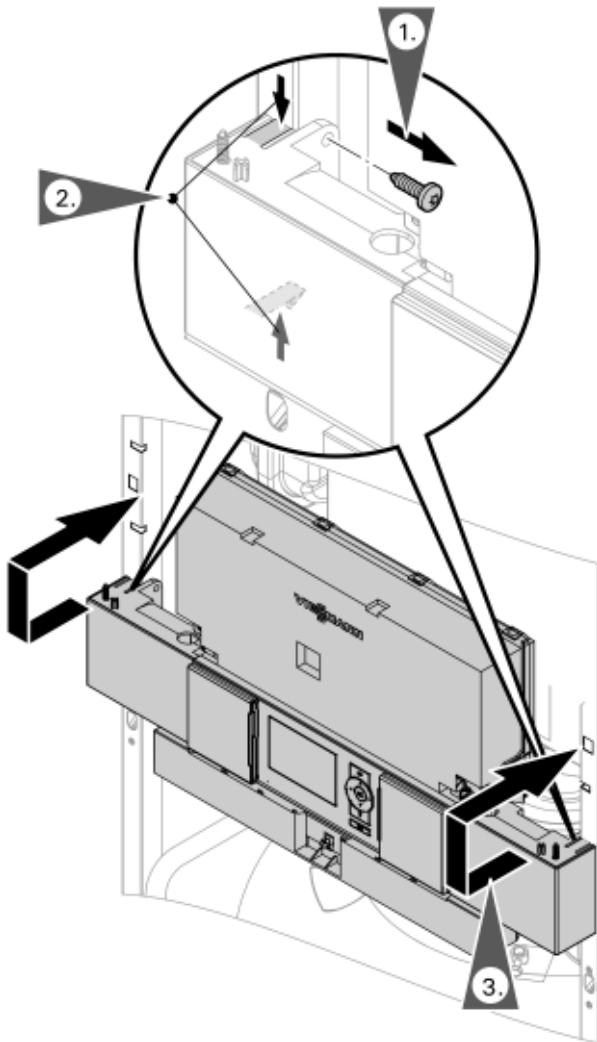

Putting control unit in maintenance position

If required for commissioning and servicing, the control unit can be put in a different position.

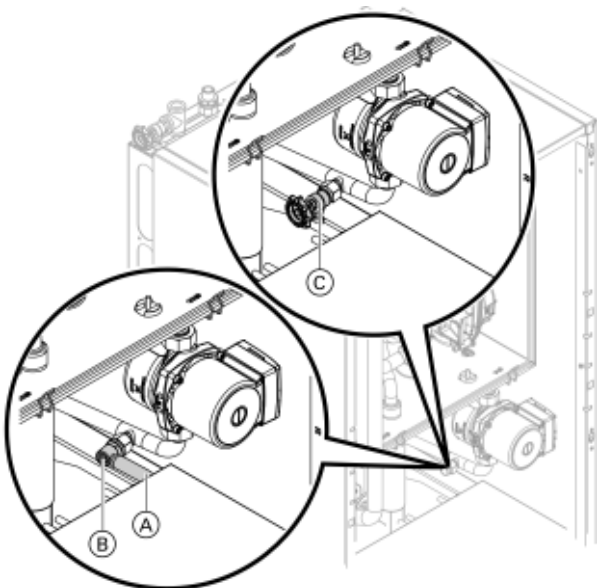

Draining the boiler on the heating water side

1. Close the shut-off valves on the heating water side.
2. Connect the drain hose (A) on valve (B) into a suitable container or drain outlet.

Note: The drain hose is located loosely inside the heat exchanger compartment. On later models there will be a factory installed sediment valve (C) and the drain hose will be field supplied.

3. Open drain valve (B) with a key and drain the boiler as much as required.

Note: The key is supplied with the installation fittings. On later models there will be a factory installed sediment valve (C) and the key will be required for air bleed (see page 14).

Corrective Action *(continued)*

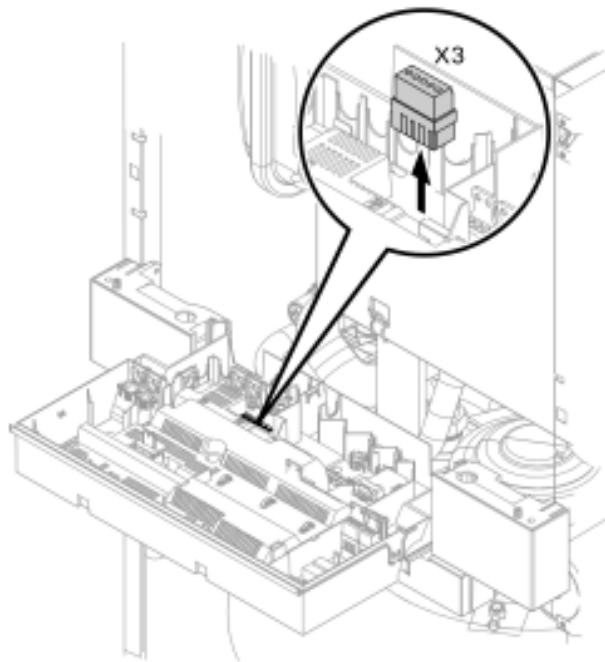

Checking the outside temperature sensor

1. Pull plug "X3" from the control unit.
2. Test the resistance of the outside temperature sensor across terminals "X3.1" and "X3.2" on the disconnected plug and compare it with the curve.
3. Where actual values deviate severely from the curve values, disconnect the wires at the sensor and repeat test on the sensor itself.
4. Depending on the result, replace the lead or the outside temperature sensor. Sensor type: NTC 10 kΩ

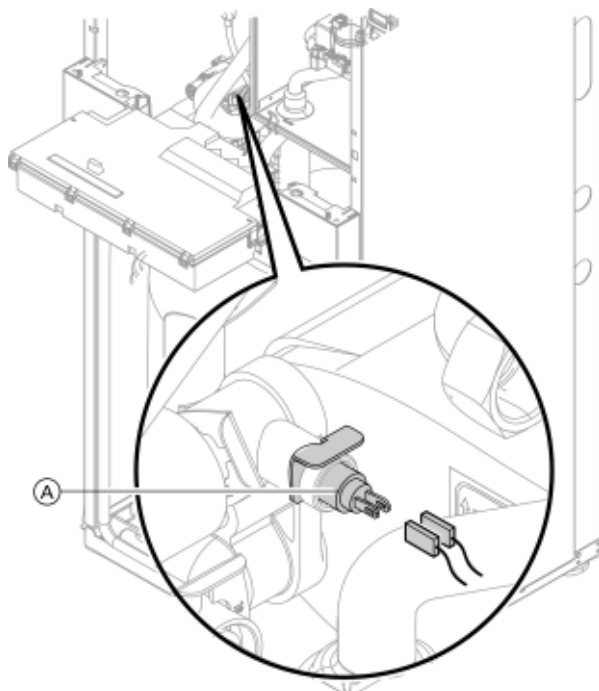
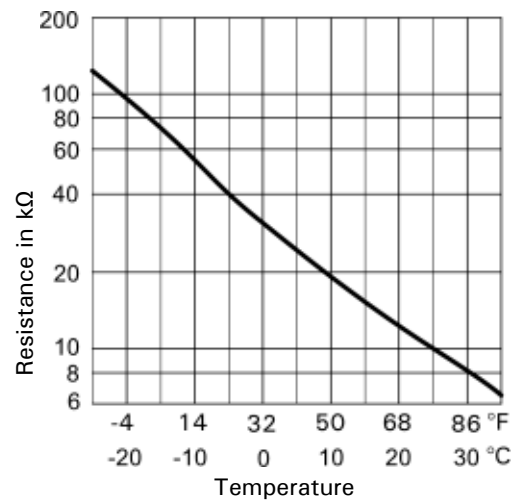

Checking the outlet temperature sensor

1. Pull the leads from outlet temperature sensor (A).
2. Check the sensor resistance and compare it with the curve.
3. Replace the sensor in the case of severe deviation.

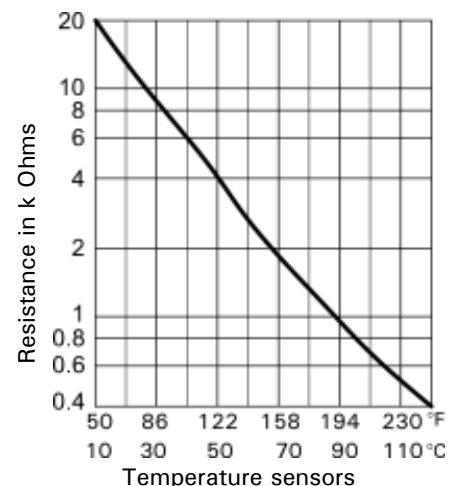

Corrective Action *(continued)*

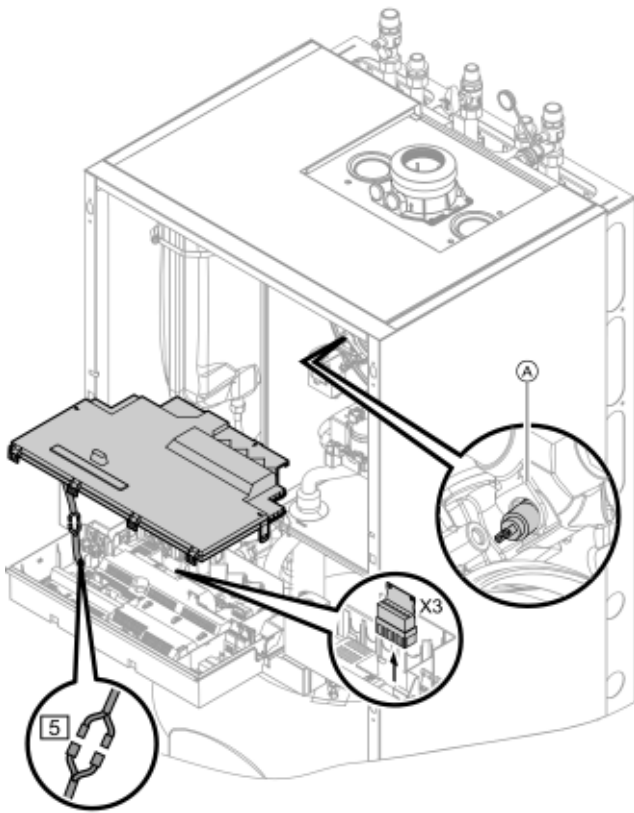

Check boiler temperature sensor, tank temperature sensor, supply temperature sensor of the low-loss header or room temperature sensor

1. Boiler temperature sensor:
Remove lead to boiler water temperature sensor (A) and check the resistance.

- DHW Tank temperature sensor:
Pull plug (5) from the cable harness at the control unit and check the resistance.

- Supply temperature sensor or Low-loss header temperature sensor (2):
Pull plug "X3" from the control unit and check the resistance across terminals "X3.4" and "X3.5".
Note: Only one temperature sensor (2) may be used.
2. Check the sensor resistance and compare the actual values with the curve.
3. Replace the sensor in the case of severe deviation.
Sensor type: NTC 10 kΩ

! WARNING
 The boiler temperature sensor is immersed in the heating water (risk of scalding). Drain the boiler before replacing the sensor.

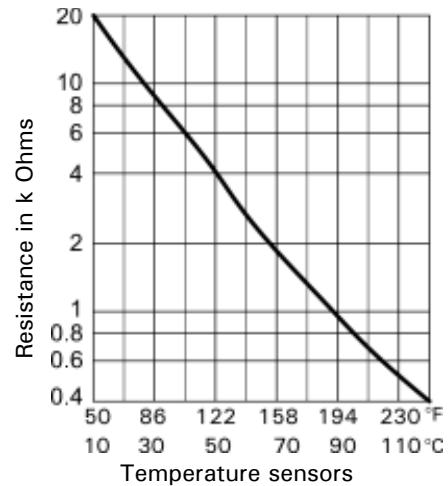

Corrective Action *(continued)*

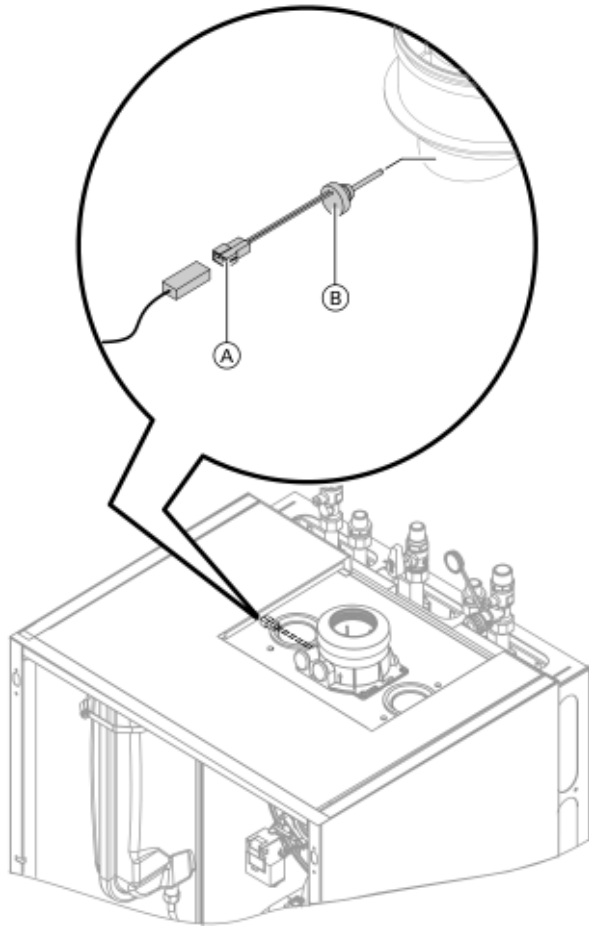

Check flue gas temperature sensor

When exceeding the maximum permissible flue gas temperature value, the flue gas temperature sensor locks the appliance. Unlock the appliance by pressing reset button **R**, after the vent system has cooled down.

1. Disconnect plug **A** from flue gas temperature sensor **B**.
2. Check the sensor resistance and compare the actual values with the curve in the chart.
3. Replace sensor in case of severe deviation.

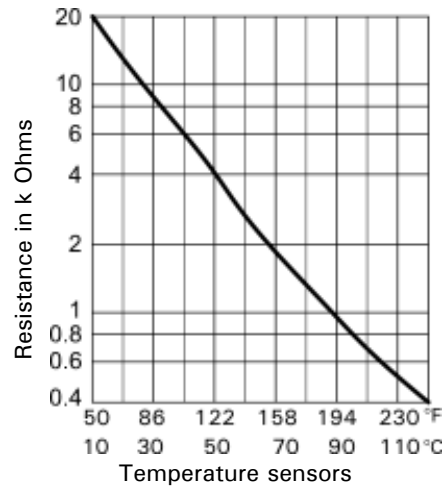

Corrective Action *(continued)*

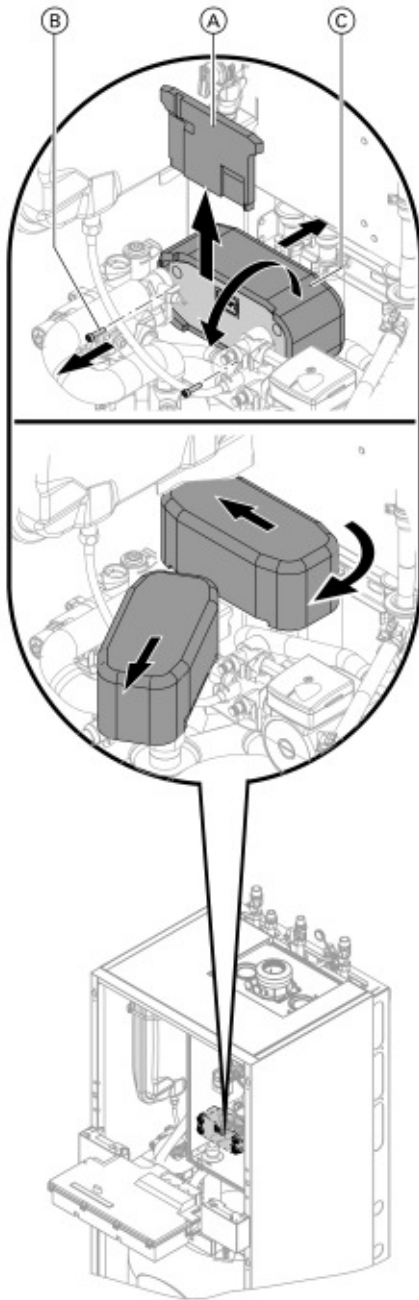

Checking the plate heat exchanger

Note: Drain the boiler on its heating water and DHW side. During removal, small amounts of water may trickle out and escape from the plate heat exchanger.

1. Shut off and drain the boiler on the heating water and DHW sides.
2. Release the side closures and pivot the control unit forward.
3. Remove the siphon (see page 23).
4. Push insulating mat (A) upwards and remove.
5. Undo two screws (B) and pull out plate heat exchanger (C) to the front.
6. Check the connections on the heating water and DHW side for contamination and scaling; if required, replace the plate heat exchanger.
7. Install in reverse order with new gaskets.

Corrective Action *(continued)*

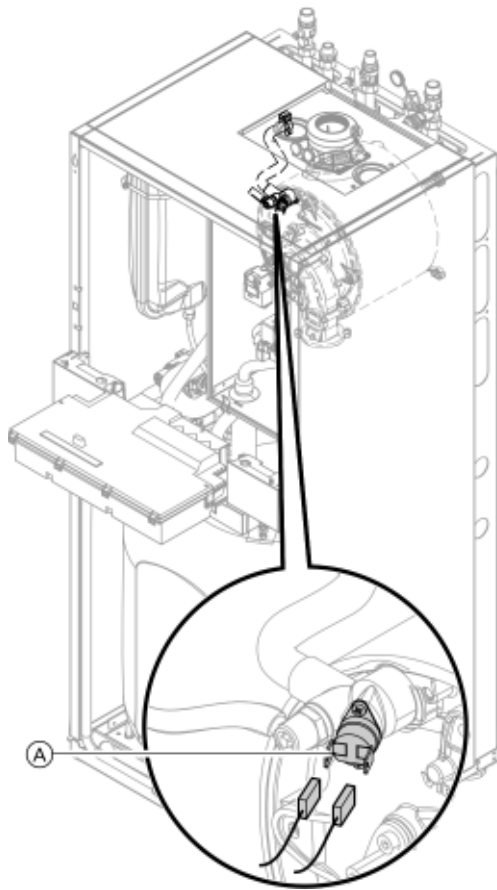

Check fixed high limit

Check the fixed high limit, if the burner control cannot be reset after a fault shutdown, although the boiler water temperature is below approximately 167° F (75° C):

1. Remove cables from the fixed high limit (A).
2. Check the continuity of the fixed high limit with a multimeter.
3. Remove and replace a defective fixed high limit.
4. After starting up the boiler, press reset button **R** on the boiler control.

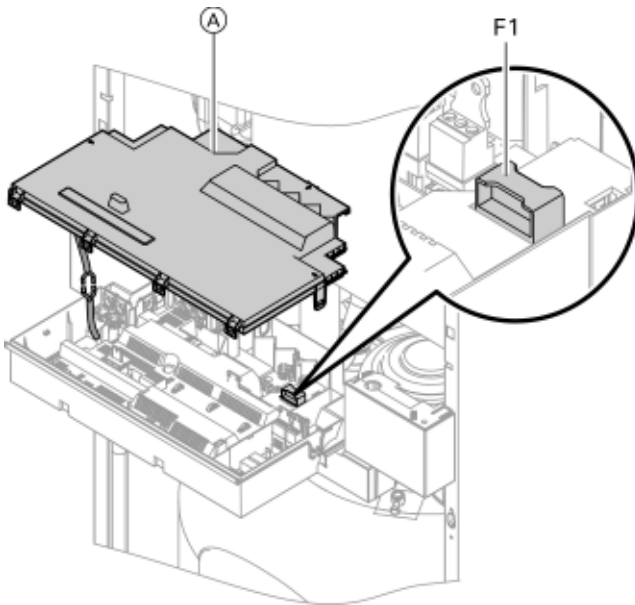



Check fuse

1. Switch OFF the power.
2. Release side latches and pivot the control unit down.
3. Remove cover (A).
4. Check fuse F1 (see wiring diagram).

Check fuses in the External Accessories Connection Box

1. Switch OFF the power.
2. Open external accessories connection box and check fuses F1 and F2 (see wiring diagram).

Corrective Action *(continued)*

Heating circuit	Rotary selector S1 setting
Heating circuit with mixing valve M2 (heating circuit 2)	2 
Heating circuit with mixing valve M3 (heating circuit 3)	4 

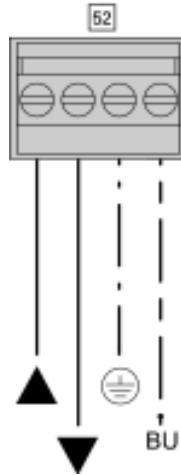

Extension kit for heating circuit with mixing valve

Checking the setting of rotary selector S1:

The rotary selector on the PCB of the extension kit defines the assignment to the relevant heating circuit.

Note: The rotational direction of the mixing valve motor during its self-test. Then set the mixing valve manually to "Open".

Note: The supply temperature sensor must now capture a higher temperature. If the temperature drops, either the motor is turning in the wrong direction or the mixing valve set is incorrectly fitted.

Checking the rotational direction of the mixing valve motor:

After being switched on, the boiler implements a self-test. During this, the mixing valve is opened and closed again.

Changing the rotational direction of the mixing valve motor (if required):

1. Remove the upper casing cover of the extension kit.

WARNING



Electric shock hazard indicates an imminently hazardous situation which, if not avoided, may result in loss of life, serious injury or substantial product / property damage. Before opening the boiler, disconnect main power.

2. At plug 52, swap the cores at terminals "▲" and "▼".
3. Refit the casing cover.

Checking the Vitotronic 200-H (accessories)

The Vitotronic 200-H is connected to the control unit via the LON cable. To test the connection, carry out a participant check at the boiler control unit (see page 40).

Corrective Action *(continued)*

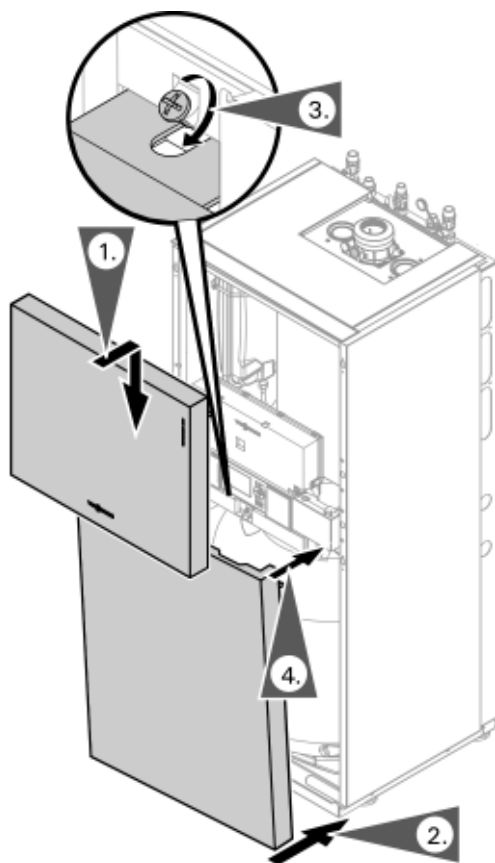

Fitting the front panels

1. Install upper front panel.
2. Set in lower front panel.
3. Insert and tighten the retaining screw.
4. Install lower front panel.

External Extensions AM1

Functions

One of the following circulation pumps can be connected to each of the connections A1 and A2:

- Heating circuit pump for the heating circuit without mixing valve
- Circulation pump for DHW tank heating
- DHW circulation pump

Select the output functions by means of the codes on the boiler control unit.

Function assignment

Function	Code ("General" group)	
	Output A1	Output A2
DHW circulation pump 28	33:0	34:0 (delivered condition)
Heating circuit pump 20	33:1 (delivered condition)	34:1
Circulation pump for cylinder heating 21	33:2	34:2

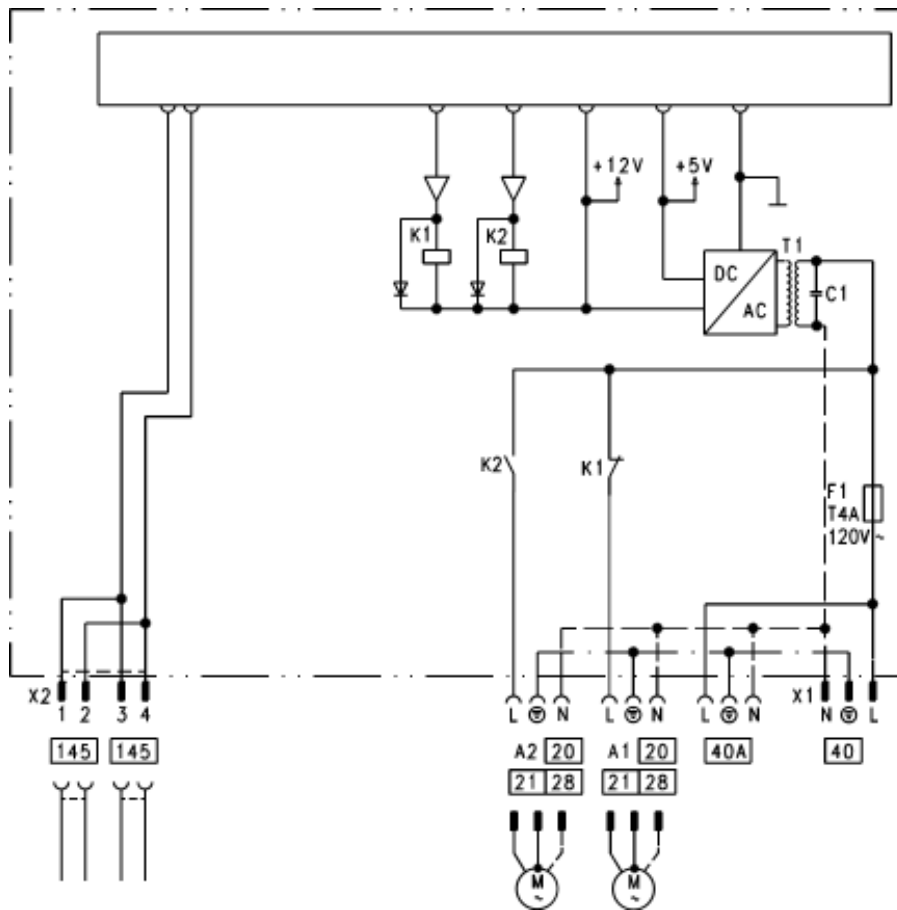

Legend

- A1 Circulation pump
- A2 Circulation pump
- 40 Power supply
- 40A Power supply for additional accessories
- 145 pump (potential-free)
- KM BUS

Refer to main wiring diagram on page 40.

Internal Extensions EA1

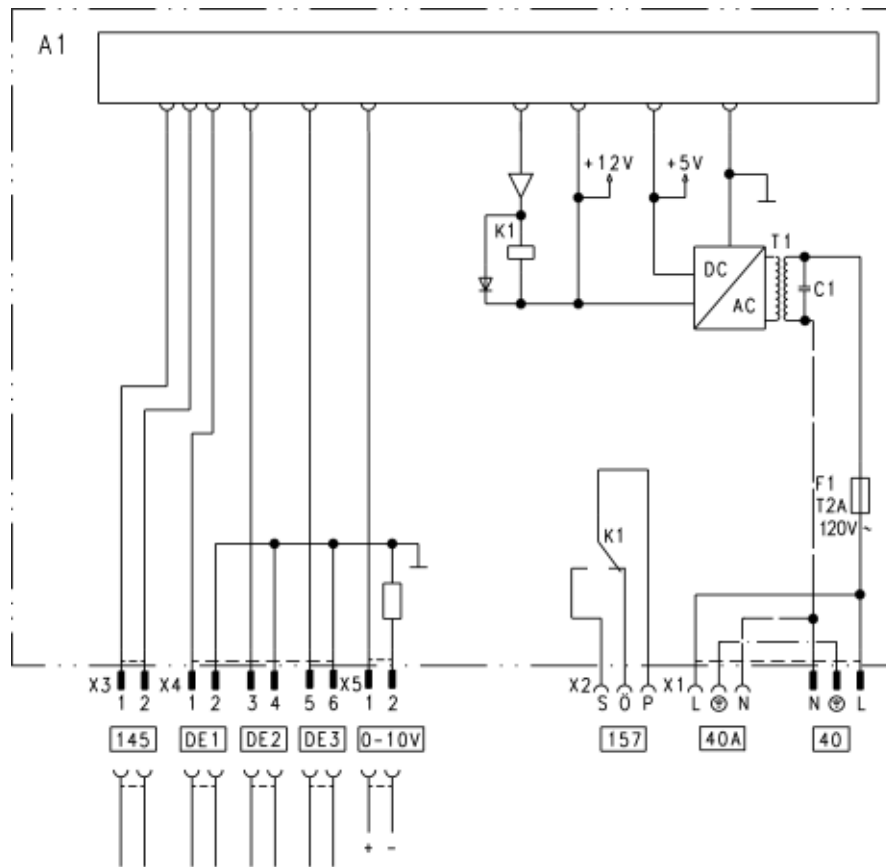

Legend

- A1 PCB
- F1 Fuse
- DE1 Digital input 1
- DE2 Digital input 2
- DE3 Digital input 3
- 0 – 10 V 0 - 10 V input
- 40 Power supply
- 40 A Power supply for additional accessories
- 157 Central fault message/ feed pump/DHW circulation pump (potential-free)
- 145 KM BUS

Refer to main wiring diagram on page 90.

Internal Extensions (Accessories)

Digital data inputs DE1 to DE3

The following functions can be connected alternatively:

- External heating program changeover for each heating circuit
- External blocking
- External blocking with fault message input
- External demand with minimum boiler water temperature
- Fault message input
- Brief operation of the DHW circulation pump

External contacts must be floating.

When connecting external contacts, observe the requirements of safety category

II, i.e. 8.0 mm air and creep path or 2.0 mm insulation thickness to 'live' parts.

Input function assignment

Select the input functions by means of codes in the "General" group at the boiler control unit:

- DE1: Coding address 3A
- DE2: Coding address 3B
- DE3: Coding address 3C

Assigning the heating program changeover function to the heating circuits

Select the heating program changeover function for the respective heating circuit via coding address D8 in the "Heating circuit" group at the boiler control unit:

- Changeover via input DE1: Code D8:1
- Changeover via input DE2: Code D8:2
- Changeover via input DE3: Code D8:3

The effect of the heating program changeover is selected via coding address D5 in the "Heating circuit" group. The duration of the changeover is set via coding address F2 in the "Heating circuit" group.

Effect of the external blocking function on the pumps

The effect on the internal circulation pump is selected in coding address 3E in the "General" group.

The effect on the respective heating circuit pump is selected in coding address D6 in the "Heating circuit" group.

The effect on a circulation pump for DHW tank heating is selected in coding address 5E in the "DHW" group.

Effect of the external demand function on the pumps

The effect on the internal circulation pump is selected in coding address 3F in the "General" group.

The effect on the respective heating circuit pump is selected in coding address D7 in the "Heating circuit" group.

The effect on a circulation pump for DHW tank heating is selected in coding address 5F in the "DHW" group.

DHW circulation pump runtime for brief operation

The DHW circulation pump is started by closing the contact at DE1, DE2 or DE3 by means of a pushbutton. The runtime is adjusted via coding address "3D" in the "General" group.

Analogue input 0 - 10 V

The 0 - 10 V hook-up provides an additional set boiler water temperature:

0 - 1 V taken as "no default for set boiler water temperature"

1 V \triangleq set value 50° F (10° C)

10 V \triangleq set value 212° F (100° C)

Ensure DC separation between the ground conductor and the negative pole of the on-site voltage source.

Output 157

The following functions can be connected to output 157:

- DHW recirculation pump
- or
- Fault message facility

Function assignment

Select the function of output 157 via coding address "36" in the "General" group at the boiler control unit.

Control Functions

External heating program changeover

The “External heating program changeover” function is connected via input “143” in the EACB.

You can select which direction the heating program changeover takes in coding address “D5”:

The “External heating program changeover” function is connected via extension EA1. There are 3 inputs available at extension EA1 (DE1 to DE3).

The function is selected via the following codes:

Heating program changeover	Coding
Input DE1	3A:1
Input DE2	3B:1
Input DE3	3C:1

Assign the heating program changeover function for the respective heating circuit with code D8 at the boiler control unit:

Heating program changeover	Coding
Changeover via input DE1	D8:1
Changeover via input DE2	D8:2
Changeover via input DE3	D8:3

You can select which direction the heating program changeover takes in coding address “D5”:

Heating program changeover	Coding
Changeover towards “Permanently reduced” or “Permanent standby” mode (based on the selected setpoint)	D5:0
Changeover towards “Constant heating mode”	D5:1

The duration of the heating program changeover can be adjusted in coding address “F2”:

Heating program changeover	Coding
No changeover	F2:0
Duration of the heating program changeover 1 to 12 hours	F2:1 to F2:12

The heating program changeover stays enabled for as long as the contact remains closed, but at least as long as the duration selected in coding address “F2”.

External blocking

The “External blocking” and “External blocking and fault message input” functions are connected via extension EA1. There are 3 inputs available at extension EA1 (DE1 to DE3).

The function is selected via the following codes:

External blocking	Coding
Input DE1	3A:3
Input DE2	3B:3
Input DE3	3C:3

External blocking and fault message input	Coding
Input DE1	3A:4
Input DE2	3B:4
Input DE3	3C:4

The effect on the internal circulation pump is selected with code 3E. Select the effect on the respective heating circuit pump with code D6.

External demand

The “External demand” function is connected via extension EA1. There are 3 inputs available at extension EA1 (DE1 to DE3). The function is selected via the following codes:

External demand	Coding
Input DE1	3A:2
Input DE2	3B:2
Input DE3	3C:2

The effect on the internal circulation pump is selected with code 3F. The effect on the respective heating circuit pump is selected with code D7.

The minimum set boiler water temperature in case of external demand is selected in coding address “9B”.

Control Functions *(continued)*

Fill program

If the system is to be filled with the control unit switched ON, code "2F:2" starts the pump. The burner shuts down if this function is enabled via coding address "2F". The program is automatically disabled after 20 minutes, and coding address "2F" is reset to "0".

Reducing the heat-up time

During the transition from operation with reduced room temperature to operation with standard room temperature, the boiler water or supply temperature will be raised in accordance with the selected heating curve. The boiler water or supply temperature can be automatically increased. The value and duration of the additional increase of the set boiler water temperature or supply temperature can be adjusted in coding addresses "FA" and "FB".

Example using the setting in the delivered condition.

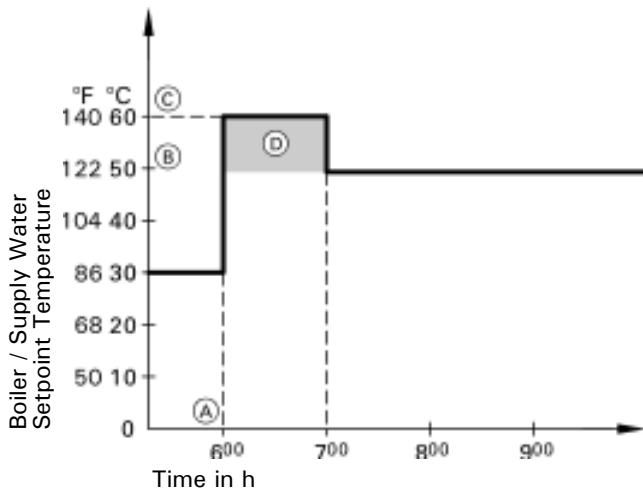

- (A) Start of operation with standard room temperature
- (B) Boiler water / supply temperature based on selected heating curve
- (C) Boiler water / supply temperature based on coding address "FA": $50^{\circ}\text{C} + 20\% = 60^{\circ}\text{C}$
- (D) Duration of operation with raised boiler water / supply temperature based on coding address "FB": 60 minutes

Raising the reduced room temperature

During operation with reduced room temperature, the reduced room setpoint temperature can be automatically raised based on the outdoor temperature. The temperature is raised in accordance with the selected heating curve, but no higher than the standard room temperature setpoint. The outdoor temperature limits for the start and end of the temperature raising can be adjusted via coding addresses "F8" and "F9".

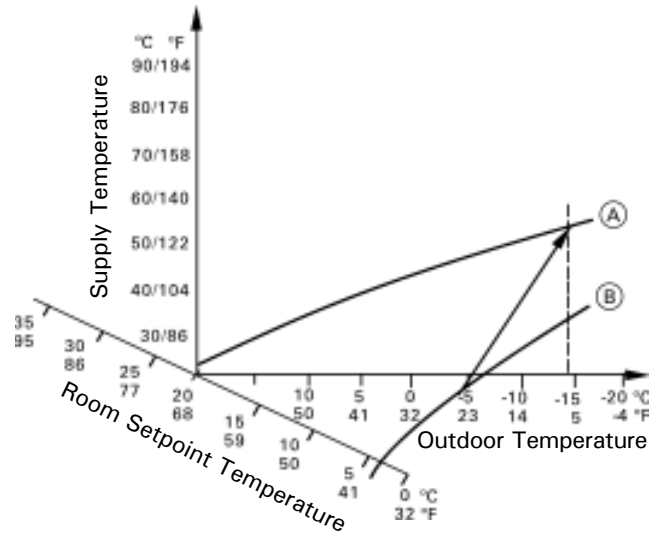

- (A) Heating curve for operation with standard room temperature
- (B) Heating curve for operation with reduced room temperature

Allocating heating circuits to the remote control

The heating circuit allocation must be configured when commissioning the Vitotrol 200A or Vitotrol 300A.

Heating circuit	Configuration	
	Vitotrol 200A	Vitotrol 300A
The remote control affects the heating circuit without mixing valve A1	H 1	HC 1
The remote control affects the heating circuit with mixing valve M2	H 2	HC 2
The remote control affects the heating circuit with mixing valve M3	H 3	HC 3

Note: One heating circuit can be allocated to the Vitotrol 200A. Up to three heating circuits can be allocated to the Vitotrol 300A. Up to 2 remote controls may be connected to the control unit. If the heating circuit allocation is later cancelled, reset coding address A0 for this heating circuit to 0 (fault message BC, BD, BE).

Wiring Diagram

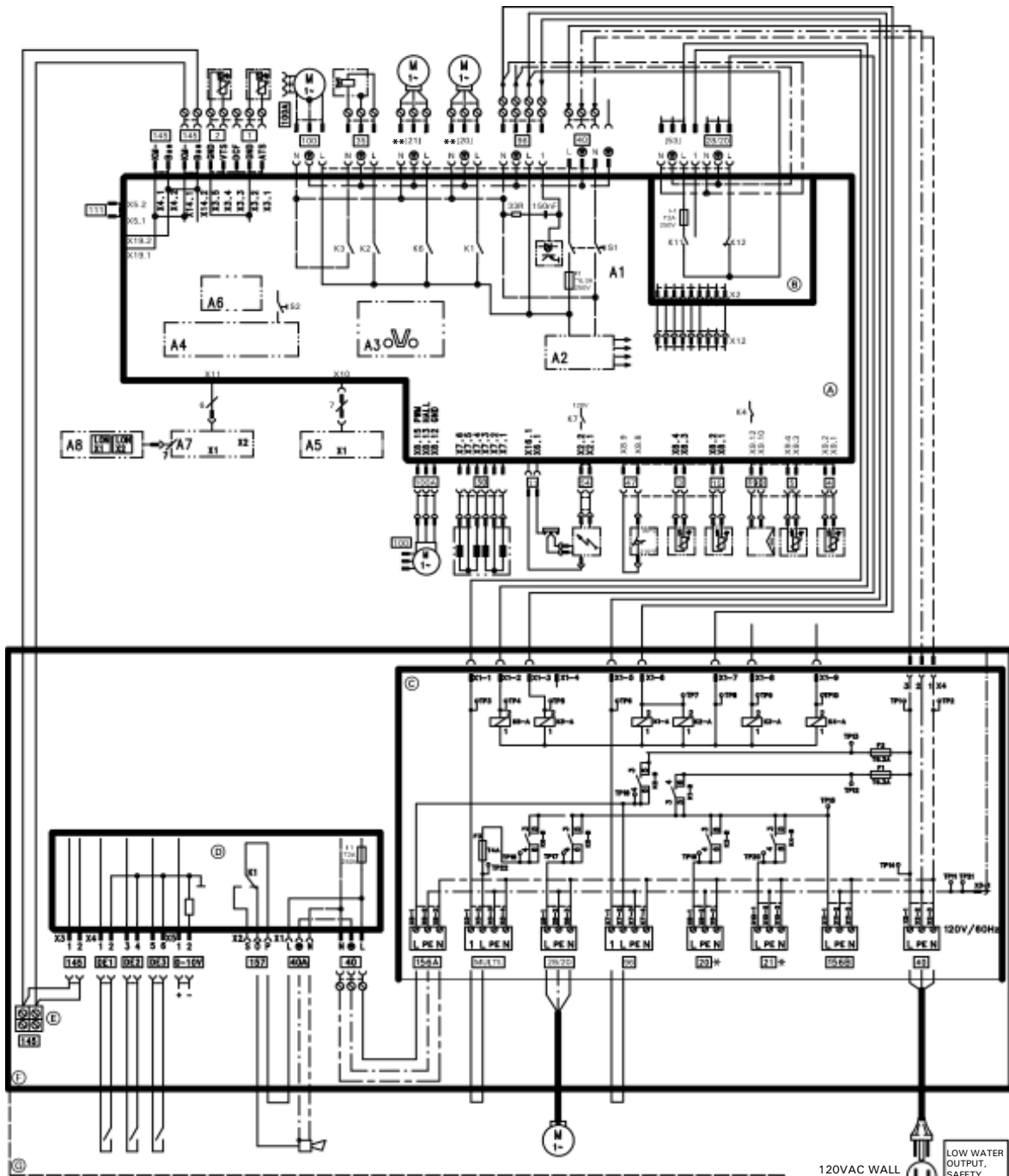

⚠ WARNING
DISCONNECT POWER BEFORE SERVICING BOILER.

If any of the original wires as supplied with the appliance must be replaced. It must be replaced with the exact equivalent.

⚠ CAUTION
 Label all wires prior to disconnection when servicing controls. Wiring errors can cause improper and dangerous operation. Verify proper operation after servicing.

- ** Only one function/connection may be assigned to each connection.
- * No Function

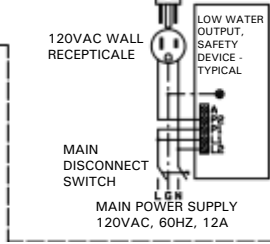

Wiring Diagram *(continued)*

Legend

1	Outdoor Temperature Sensor
2	Supply Temperature Sensor/Low Loss Header
3	Boiler Temperature Sensor
4	DHW Supply Temperature Sensor
5	DHW tank temperature sensor
11	Ionization Electrode
15	Flue Gas Temperature Sensor
20	No Function*
[20]	Boiler Pump Connection (Internal) **
21	No Function*
[21]	DHW Pump Connection (Internal) **
28/20	Heat Circuit A1 Pump Connection
30	Diverting Valve Stepper Motor
35	Gas Valve
40	Power Supply
40A	Accessory Power Output
47	Fixed High Limit
[53]	Powered Accessory Connection
54	Ignition Transformer
96	Powered Accessory Connection
100	Fan Motor
100A	Fan Motor Control
111	Not Used
145	KM BUS
Multi	Powered Accessory Connection
156A	Switched Output F2
156B	Switched Output F1
DE1	Digital Input 1 (Dry Contact)
DE2	Digital Input 2 (Dry Contact)
DE3	Digital Input 3 (Dry Contact)
0-10V	0-10VDC Input
157	Fault Alarm
190	Gas Modulation Coil

** Only one function/connection may be assigned to each connection.

- Ⓐ Boiler Control
- Ⓑ External Accessory Connection Board
- Ⓒ Pump Connection Interface
- Ⓓ Extention Module EA1
- Ⓔ KM-BUS for External Devices
- Ⓕ Electrical Junction Box
- Ⓖ Field Wiring Connections
- A1 Main Board
- A2 Internal Power Supply Unit
- A3 Optolink
- A4 Burner Control Unit
- A5 Programming Unit
- A6 Coding Card
- A7 Connection Adaptor
- A8 LON Communication Module
- S1 ON/OFF Switch
- S2 Reset Button
- X.. Electrical Interface

Burner Program Sequence of Operation

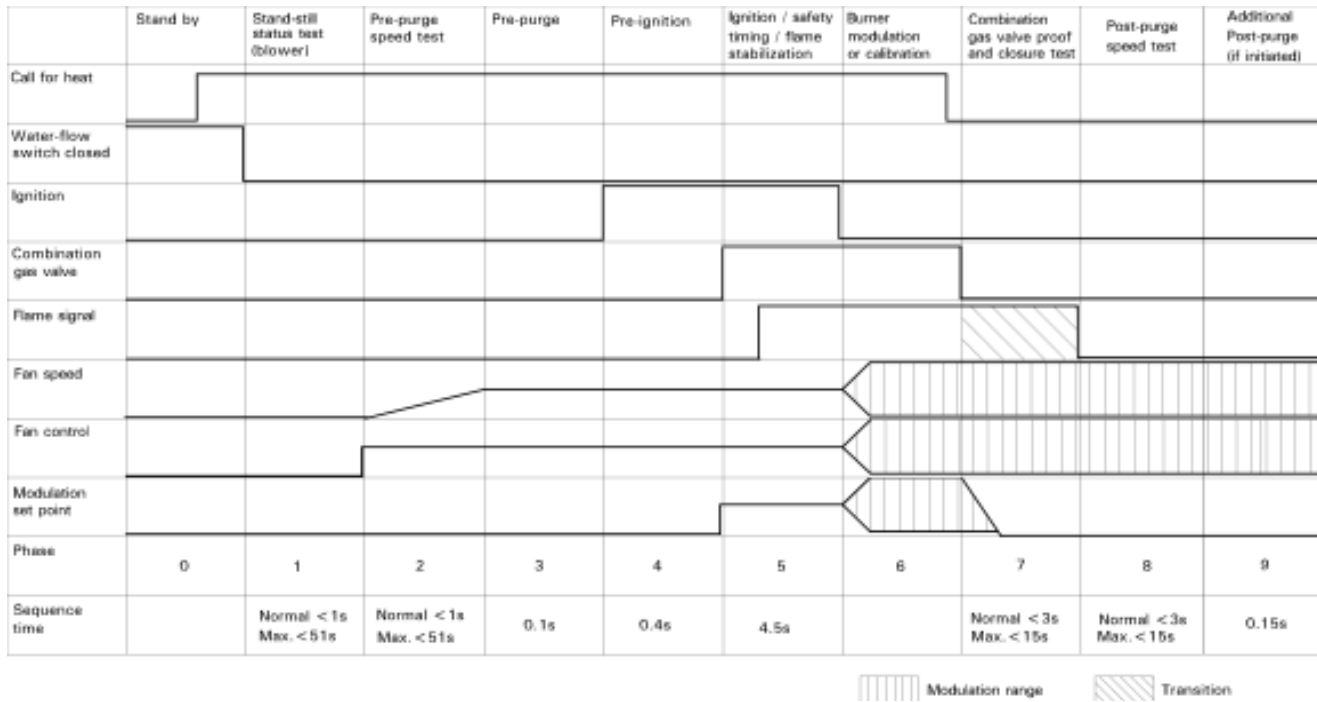

Phase 0: Stand-by

Complete shutdown until the next call for heat. In this phase both the combination gas valve and the blower are not energized.

Phase 1: Stand-still status test (blower)

A call for heat initiates internal blower sensory communications to confirm that the blower is truly in stand-still position. Blower speed measured must be < 300 rpm within a 51 second period.

Phase 2: Pre-purge speed test

Controller sends and receives signal to/from fan speed controller to verify maximum rpm of the blower.

Phase 3: Pre-purge

Pre-purge cycle starts within the pre-programmed timing. Pre-purge timing is in addition to previous phase (2). The fan speed must be greater than and within the range of rpm requested by the controller.

Phase 4: Pre-ignition

The ignition spark is initiated and controlled.

Phase 5: Ignition / safety timing / flame stabilization

The gas valve opens during the safety timing period (4.5 seconds). If a flame is detected, this phase ends immediately in < 1.5 seconds. If the flame is not established after 3 trials, the burner will lock out and will require a manual reset. Controller required time for flame stabilization.

Phase 6: Burner modulation operation or calibration

At the end of the flame stabilization period (4.5 seconds.), a release for modulation occurs and the burner temperature controller will take over from the flame safeguard. Forced shutdown after 24 hours continuous operation. Automatic calibration may be initiated by the controller.

Phase 7: Combination gas valve proof of closure test

If during the normal operation of the burner a controlled (or uncontrolled) shut-down occurs, a complete mechanical and electrical gas valve proof of closure test will be performed by the flame safeguard. After a successful mechanical and electrical proof of closure test, the flame safeguard will expect that the flame is not present. If, however, the flame existed for a period of > 15 seconds, the flame safeguard will go into permanent lock-out.

Phase 8: Post-purge speed test

Both gas valves are closed during this phase. End call for heat. Post-purge occurs during the programmed period.

Phase 9: Additional post-purge

If the fixed high limit trips during normal operation, the blower will purge for 15 minutes to cool the heat exchanger.

Parts Lists

Model No. **Serial No.**
 B2TA 19 Boiler 7510826□□□□□□□□□□
 B2TA 35 Boiler 7510827□□□□□□□□□□

Ordering Replacement Parts:

Please provide Model and Serial Number from (A) when ordering replacement parts. Order replacement components from your Viessmann distributor.

Parts for Main Enclosure Assembly

- 0001 Cover panel, top front
- 0002 Nameplate "Viessmann"
- 0003 Retaining clip (Set of 4)
- 0004 Interior cover panel with gaskets
- 0005 Gasket L=520 mm
- 0006 Leveling bolt
- 0007 Control bracket
- 0008 Side panel, right
- 0009 Side panel, left
- 0010 Mounting bracket for DHW tank
- 0011 Sealing grommet, DN60
- 0012 Top panel
- 0013 Cover panel, bottom front
- 0014 Mounting stud
- 0015 Mounting rail, left
- 0016 Mounting rail, right
- 0017 Electrical box
- 0018 Electrical box

Other Parts (not illustrated)

- 0301 Touch-up spray paint "Vitowhite"
- 0302 Touch-up paint stick "Vitowhite"
- 0303 Lubricant 6g
- 0320 Technical Literature Set
- 0321 Installation Instructions
- 0322 Service Instructions
- 0323 Operating Instructions
- 0324 Parts List for Vitodens 222
- 0325 Parts List for Installation Set (left/right)
- 0326 Parts List for Installation Set (top)
- 0330 Installation Instructions, Coaxial Venting
- 0331 Installation Instructions, Flex Venting
- 0340 Warranty Sheet, Condensing Boilers

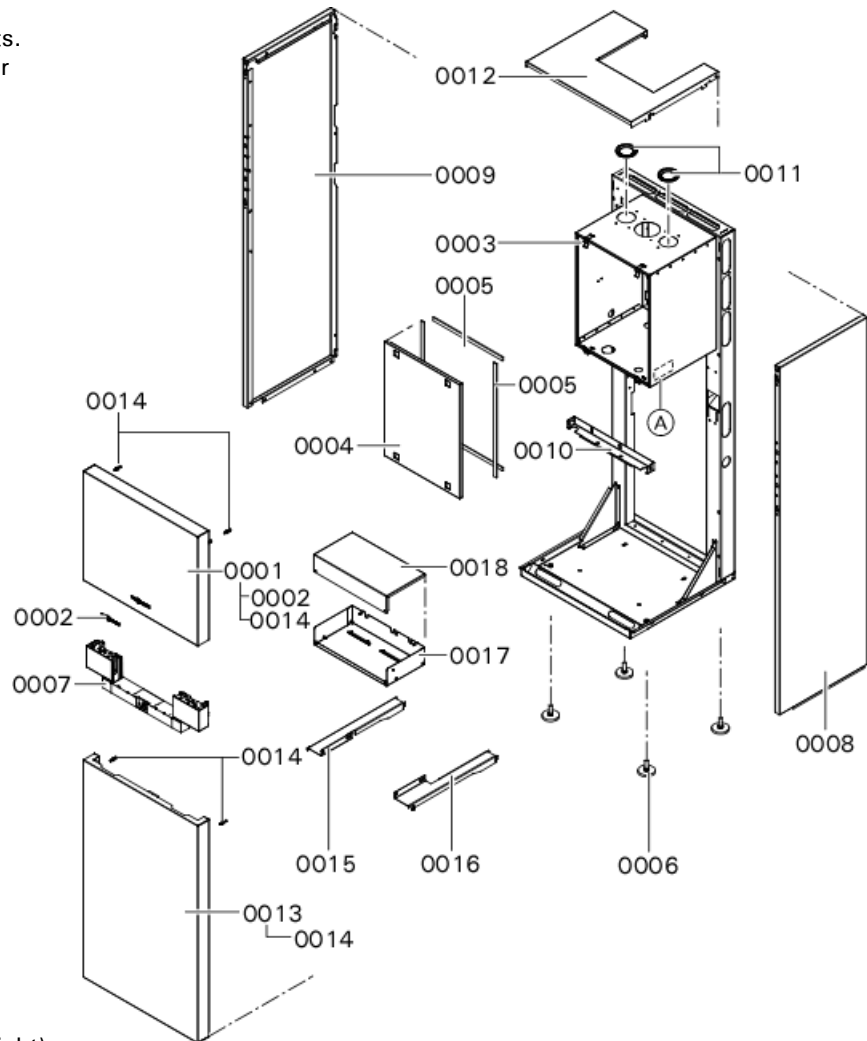

Parts Lists *(continued)*

Model No. **Serial No.**
 B2TA 19 Boiler 7510826□□□□□□□□□□
 B2TA 35 Boiler 7510827□□□□□□□□□□

Ordering Replacement Parts:

Please provide Model and Serial Number when ordering replacement parts. Order replacement components from your Viessmann distributor.

- 0001 Air intake cover
- 0002 Gasket for air intake DN60
- 0003 Vent pipe adaptor 60/100
- 0004 Test port cap (Set of 2)
- 0005 Gasket for flue gas, DN60
- 0006 Sensor for flue gas
- 0007 ASME Heat exchanger assembly
- 0008 Combustion chamber refractory
- 0009 Condensate pipe, top section
- 0010 Condensate trap
- 0011 O-Ring 35x4mm (Set of 5)
- 0012 Mounting clip for condensate drain
- 0013 Condensate flex hose
- 0014 Gas valve flex pipe
- 0015 Gasket Set A17x24x2mm (Set of 5)
- 0016 Sealing grommet for gas pipe
- 0017 Support bracket set for heat exchanger
- 0018 Pipe clip dia. = 18x1.5mm

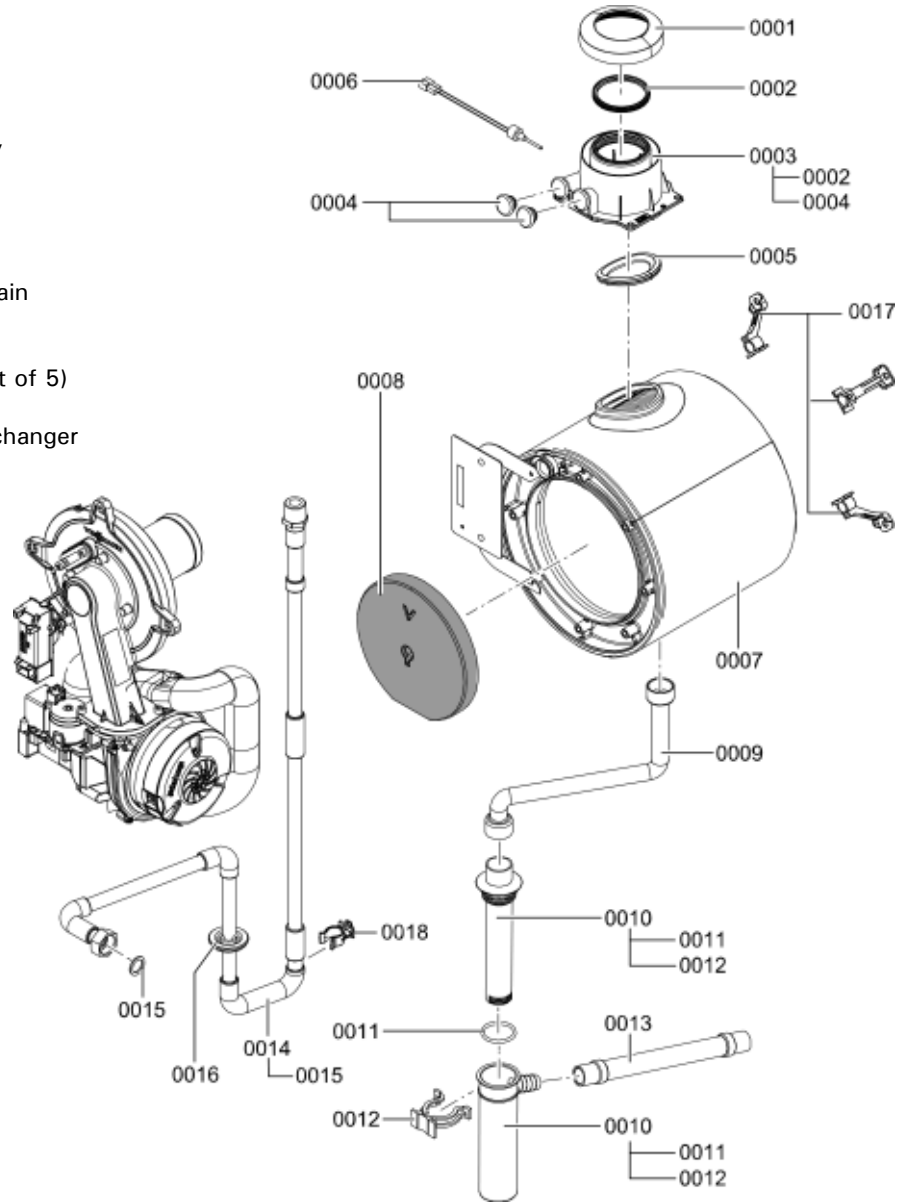

Parts Lists *(continued)*

Model No.	Serial No.
B2TA 19 Boiler	7510826□□□□□□□□□□
B2TA 35 Boiler	7510827□□□□□□□□□□

Ordering Replacement Parts:

Please provide Model and Serial Number when ordering replacement parts. Order replacement components from your Viessmann distributor.

- 0001 Burner gasket, 187x5.5 mm
- 0002 Combustion chamber door refractoy
- 0003 Burner tube, NG/LP
- 0004 Gasket for burner tube
- 0005 Ignition electrode
- 0006 Ionization electrode
- 0007 Flapper membrane
- 0008 Radial fan NRG118 with flapper
- 0009 Gas valve CES10, 120/1/60
- 0010 Burner mounting flange assembly
- 0011 Ignition adaptor
- 0012 Gasket for electrode block
- 0013 Gasket for ignition electrode
- 0014 Clip for ground (Set of 10)
- 0015 Turbulator disc
- 0016 Orifice, NG/LPG
- 0017 Venturi extension w gasket
- 0018 Bracket (Set of 2)
- 0019 Gasket, DN65 (Set of 2)
- 0020 Stabilization plate for ignition adaptor

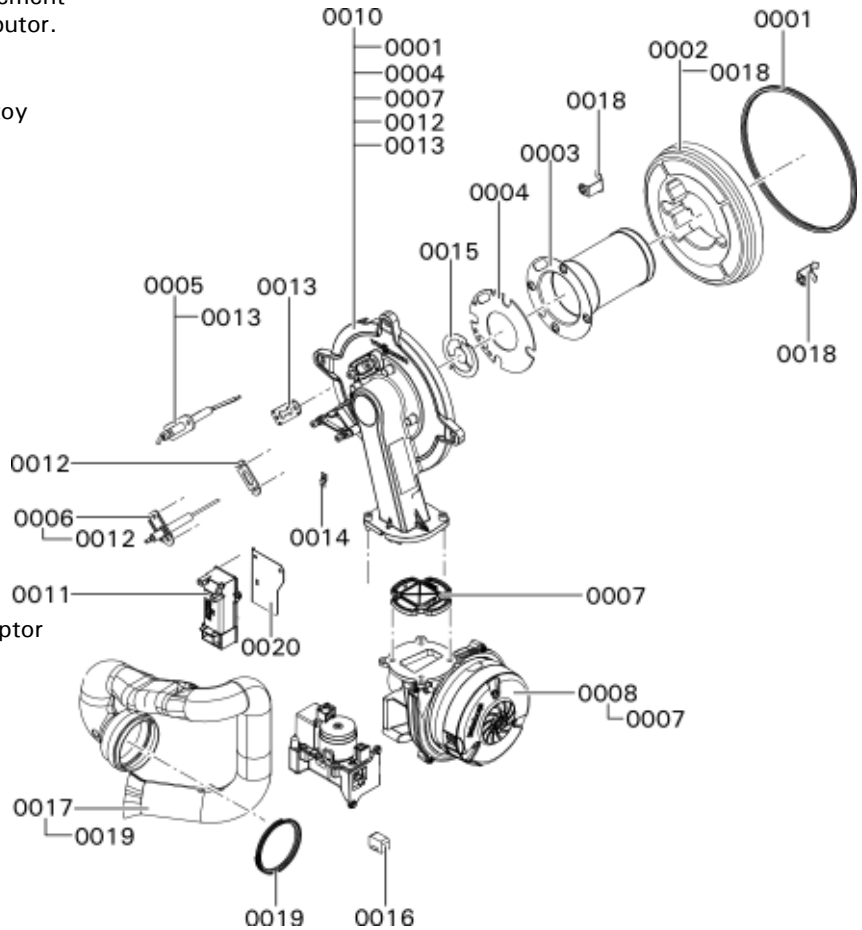

Parts Lists *(continued)*

Model No.	Serial No.
B2TA 19 Boiler	7510826□□□□□□□□□□
B2TA 35 Boiler	7510827□□□□□□□□□□

Ordering Replacement Parts:

Please provide Model and Serial Number when ordering replacement parts. Order replacement components from your Viessmann distributor.

Parts for Control Assembly

- 0001 Control console
- 0002 Control housing, rear
- 0003 Coding plug
- 0004 Fuse, 6.3A/250V (Pkg of 10)
- 0005 Fuse holder
- 0007 Vitotronic 200 HO1B
- 0008 LON Communication module H01
- 0009 Circuit board (LON module adaptor)
- 0010 Cable harness X8/X9/Ioniz.
- 0011 Cable harness 100/35/54/PE
- 0013 Counter plug, Neptune
- 0014 Strain relief (Set of 10)
- 0015 Locking assembly (left/right)
- 0016 Outdoor temperature sensor, NTC
- 0017 Circuit board for expanded functions
- 0020 Power/pump control module
- 0021 Extension module EA1, 120/1/60
- 0022 Fuse, 2.0A/250V (Pkg of 10)
- 0023 Harness set for power/pump control module

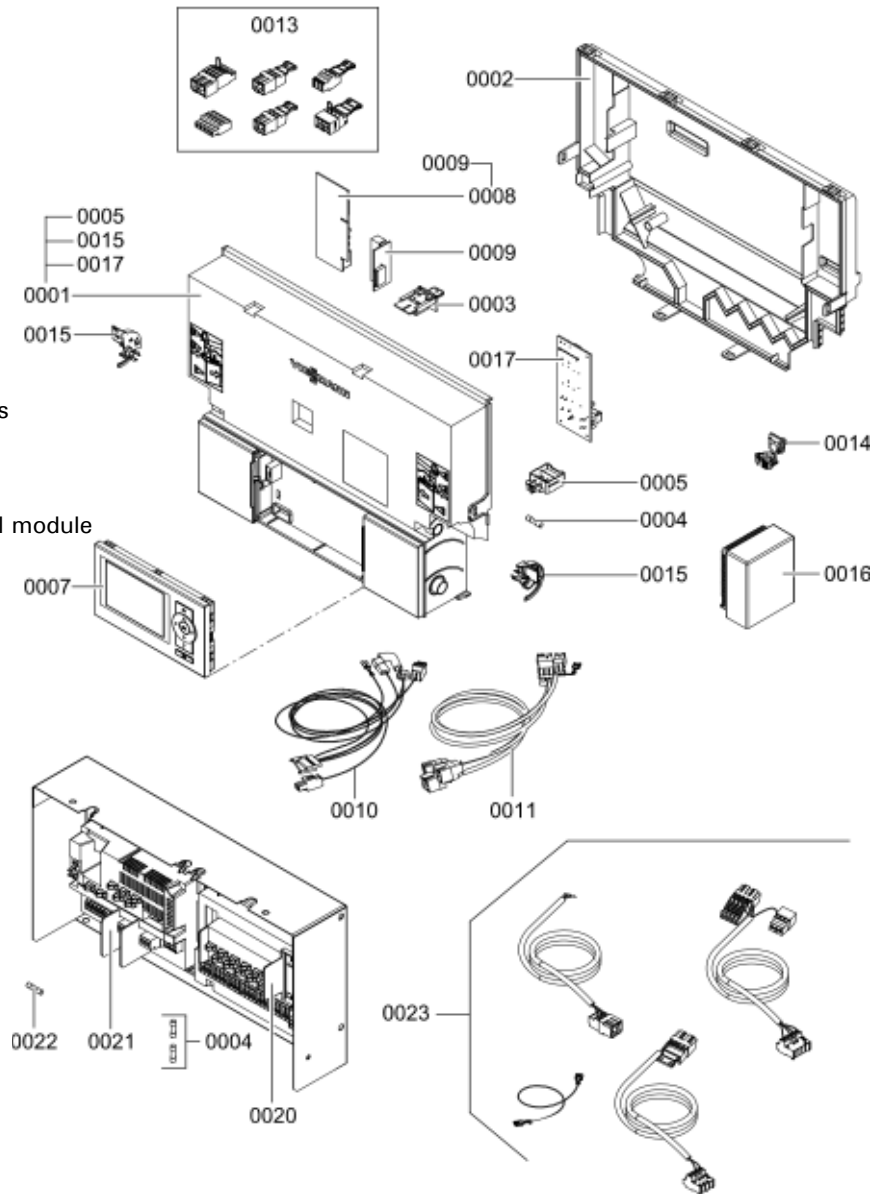

Parts Lists *(continued)*

Model No.	Serial No.
B2TA 19 Boiler	7510826□□□□□□□□
B2TA 35 Boiler	7510827□□□□□□□□

Ordering Replacement Parts:

Please provide Model and Serial Number when ordering replacement parts. Order replacement components from your Viessmann distributor.

- 0001 Hydraulic block
- 0002 Connector retaining clip (Set of 2)
- 0003 Sealing grommet (Set of 5)
- 0004 Cable tie (Each)
- 0005 Clip dia. = 8 mm (Set of 5)
- 0006 Clip for pressure gage (Set of 5)
- 0007 Locking clip dia. = 18 mm (Set of 5)
- 0008 Locking clip dia. = 18 mm (Set of 5)
- 0009 Air bleed valve, G3/8"
- 0010 Fastening clip (Set of 5)
- 0011 Connecting pipe #2 for return
- 0012 Pipe clip dia. = 18x1.5 mm
- 0013 Plug
- 0014 Pipe clip dia. = 18 mm
- 0015 Union nut G1"
- 0016 O-Ring set for heat exchanger, 21x3 mm
- 0017 Connecting pipe for heating system supply
- 0018 Connecting pipe for DHW system supply
- 0019 O-Ring for DHW, 14.3x2.4 (Set of 5)
- 0020 Flex pipe for expansion tank, MAG G3/8"
- 0021 Connecting pipe for DCW hydraulic
- 0022 Circulation pump UPS15-48 for DHW
- 0023 Impeller CIL2 PPS
- 0024 Cartridge OV20/DN20
- 0025 Pipe clip dia. = 22x42 mm (Set of 2)
- 0026 Gasket 8x2 mm (Set of 5)
- 0027 Nipple, 3/4" x G 3/4"
- 0028 Nipple, 3/4" x quick-connect
- 0029 Connecting pipe for common supply #1
- 0030 Expansion tank, 12L
- 0031 Connector retaining clip
- 0032 Connecting pipe for return #3
- 0033 Fixed high limit, 210° F (99° C)
- 0034 Drain hose 10x1.5x1500 mm
- 0035 Pressure gage with clip and gasket
- 0036 Pressure relief valve * 1
- 0037 Connecting pipe for common supply #2
- 0038 Air vent
- 0039 Circulation pump UPS15-78 for space heating
- 0040 Impeller CIA02
- 0041 Gasket set for gas connection pipe, 17x24x2 mm
- 0042 Gasket 23x30x2 mm (Set of 5)
- 0043 Boiler temperature sensor
- 0044 Heating return connection pipe for heat exchanger
- 0045 Flex pipe for boiler discharge
- 0046 Gasket, A10x15x1.5 mm, (Set of 5)
- 0047 O-Ring set for supply/return, 18x3 mm

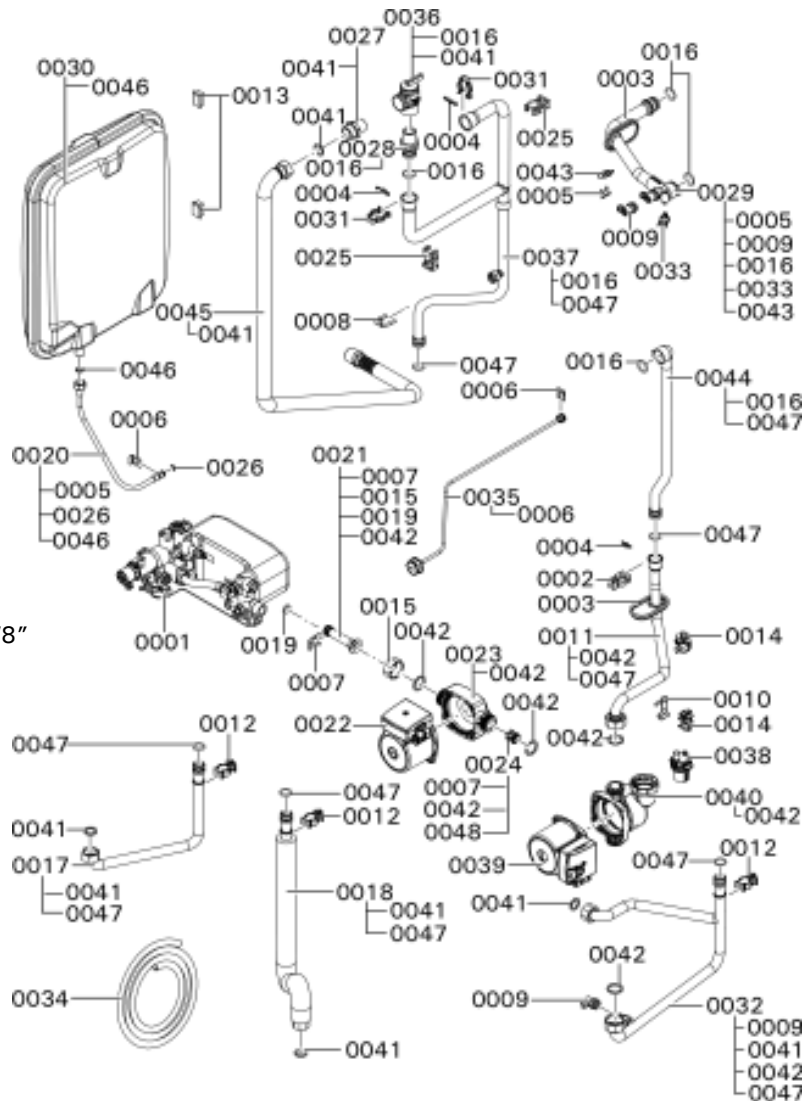

5883 714 - 01

Parts Lists *(continued)*

Model No.	Serial No.
B2TA 19 Boiler	7510826□□□□□□□□
B2TA 35 Boiler	7510827□□□□□□□□

Ordering Replacement Parts:

Please provide Model and Serial Number when ordering replacement parts. Order replacement components from your Viessmann distributor.

- 0001 Return connecting pipe
- 0002 Profile gasket
- 0003 Plug, dia. = 8mm / dia. = 10mm
- 0004 Clip dia. = 8 mm (Set of 5)
- 0005 Clip for pressure gage (Set of 5)
- 0006 Locking clip dia. = 18 mm
- 0007 Support bracket
- 0008 Insulation plate
- 0009 Insulation shell
- 0010 Pressure bypass pipe
- 0011 Supply connecting pipe
- 0012 Valve insert
- 0013 Pressure bypass valve
- 0014 O-Ring set for supply/return 18x3 mm
- 0015 Gasket set, 17x24x2 mm
- 0016 Gasket set, 10x2 mm
- 0017 Temperature sensor
- 0018 DHW Heat exchanger

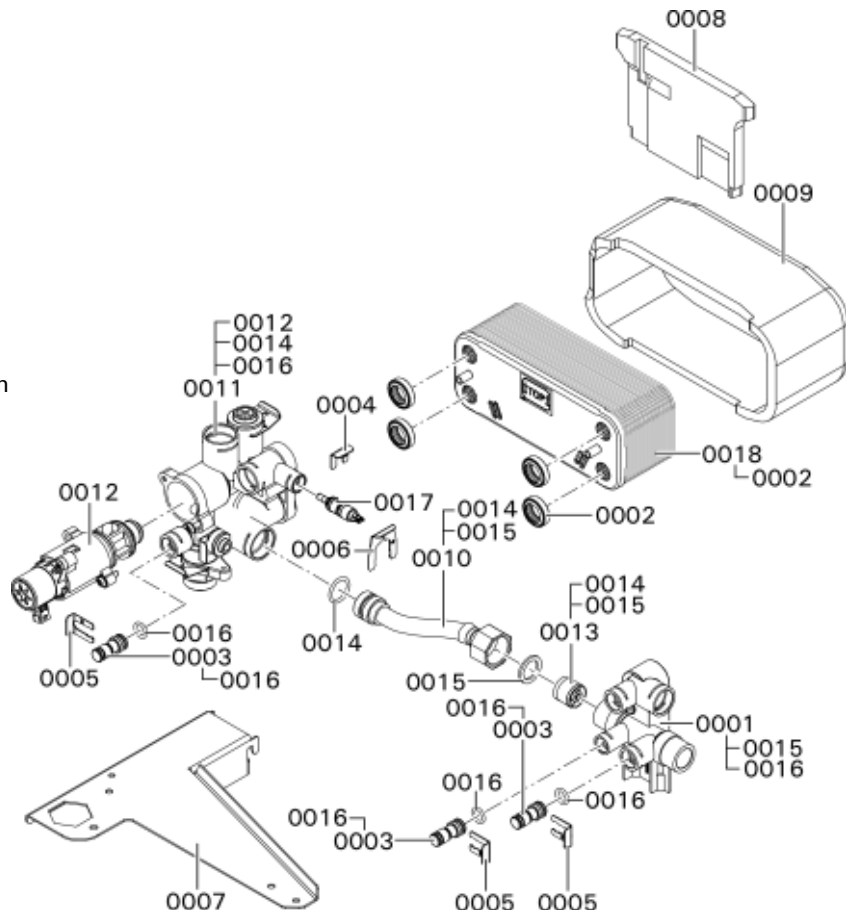

Parts Lists *(continued)*

Model No.	Serial No.
B2TA 19 Boiler	7510826□□□□□□□□□□
B2TA 35 Boiler	7510827□□□□□□□□□□

Ordering Replacement Parts:

Please provide Model and Serial Number when ordering replacement parts. Order replacement components from your Viessmann distributor.

- 0001 Flex pipe for tank discharge
- 0002 Gasket set for gas connection pipe, 17x24x2
- 0003 Nipple, 3/4" x G 3/4"
- 0004 DHW tank with T&P valve, 26 USG/100 L
- 0005 Isolation valve (elbow) for DHW inlet
- 0006 DCW Connecting pipe #2 for tank
- 0007 Connector retaining clip (Set of 2)
- 0008 Cable tie (each)
- 0009 O-Ring set for supply/return, 18x3 mm
- 0010 DCW Connecting pipe #1 for tank
- 0011 Pipe clip dia. = 18x1.5 mm
- 0012 Gasket, 23x30x2 mm (Set of 5)
- 0013 O-Ring for DHW, 14.3x2.4 mm (Set of 5)
- 0014 Locking clip dia. = 15 mm (Set of 5)
- 0015 Connecting pipe for tank recirculation
- 0016 Flow regulator
- 0017 Isolation valve (elbow) for DHW outlet
- 0018 Cap, G3/4" SW30

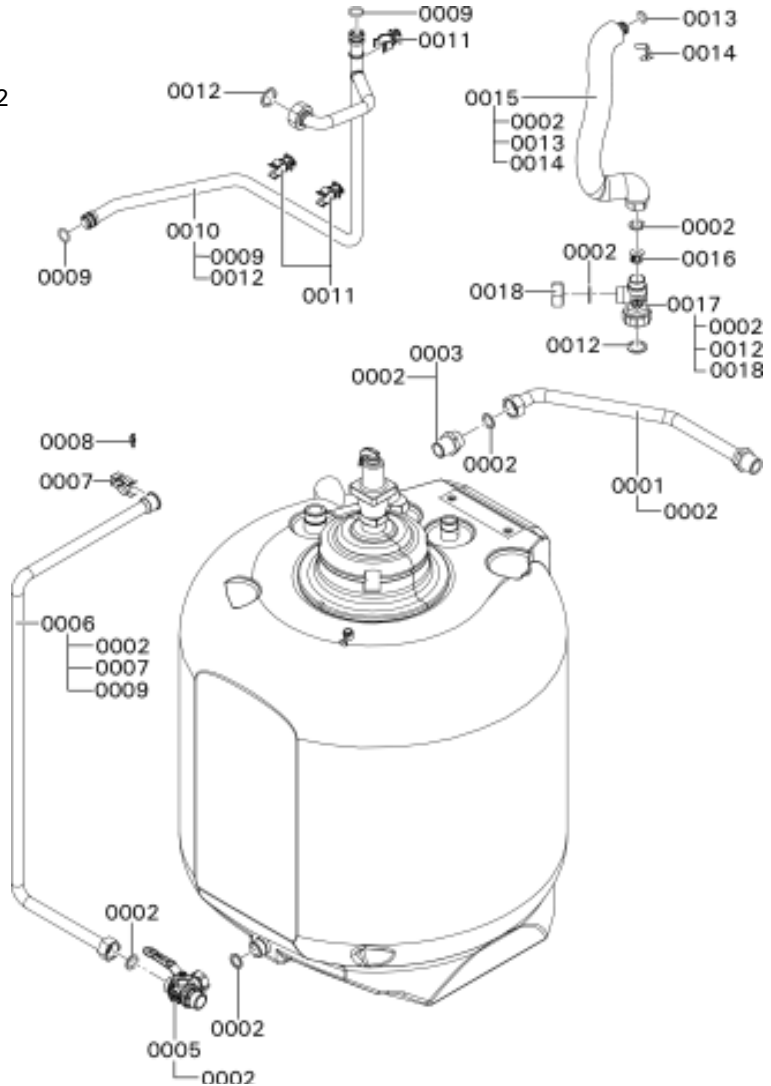

Parts Lists *(continued)*

Model No. **Serial No.**
 B2TA 19 Boiler 7510826□□□□□□□□□□
 B2TA 35 Boiler 7510827□□□□□□□□□□

Ordering Replacement Parts:

Please provide Model and Serial Number when ordering replacement parts. Order replacement components from your Viessmann distributor.

- 0001 Insulation
- 0002 T&P valve, 150 psi
- 0003 Tank clean out cover G4 with gasket
- 0004 Nipple 3/4" NPT
- 0005 Gasket
- 0006 Flat gasket
- 0007 Cap G 3/4 with gasket
- 0008 DHW sensor NTC 10k
- 0009 Strain relief
- 0010 DHW tank 26.5 USG (100 L) assembly

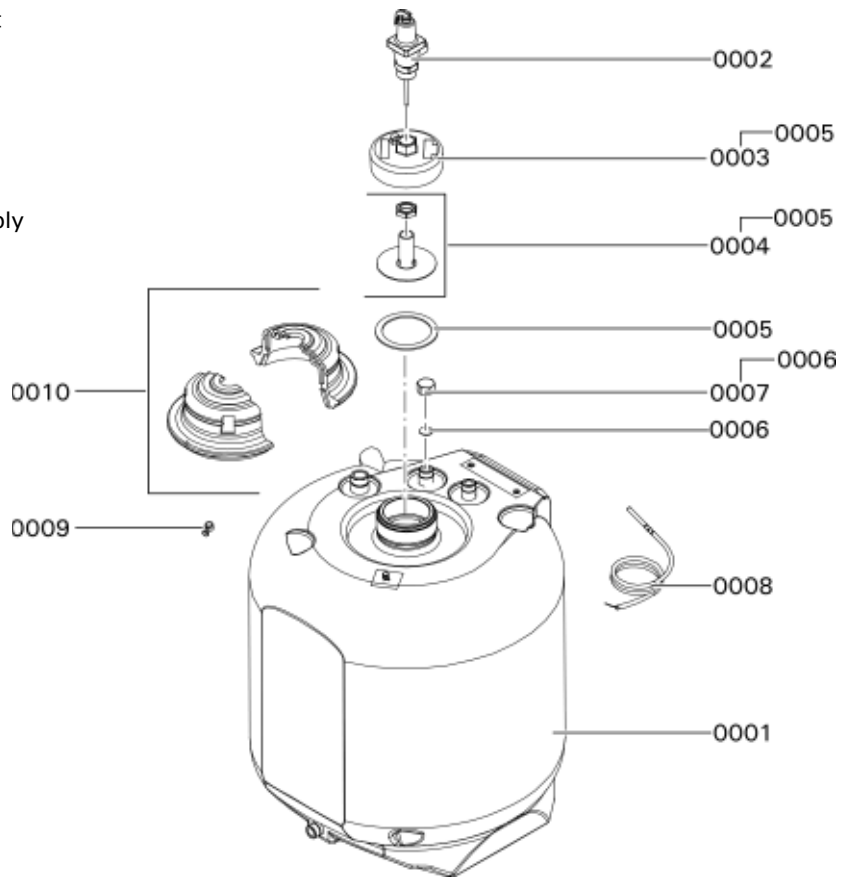

Installation Fittings

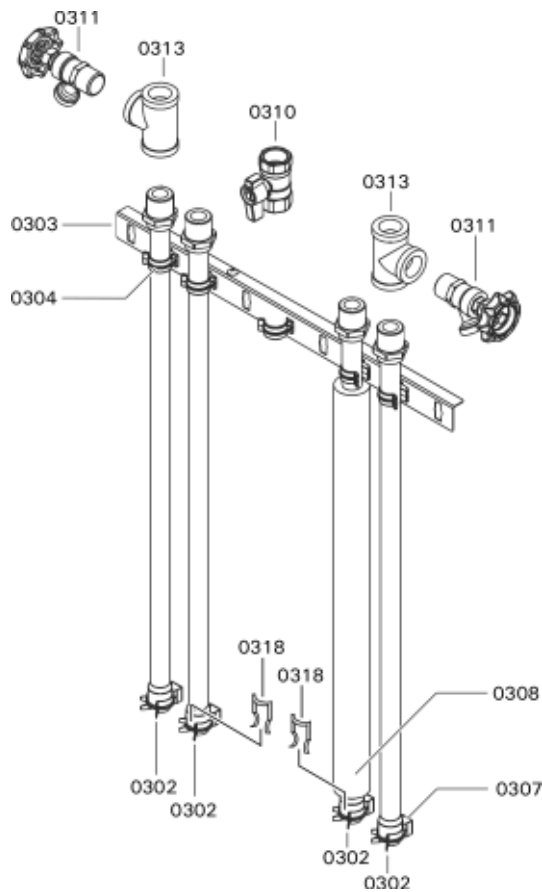

Parts for Top Connection

- 0301 Flex pipe (NG/LP), full-length
- 0302 Connecting pipe, DHW/heating
- 0303 Support bracket with pipe clips
- 0304 Pipe clip (each)
- 0307 Connector retaining clip (Set of 2)
- 0308 Pipe insulation, 19x9x740mm
- 0310 Gas ball valve, 3/4" brass
- 0311 Sediment faucet, 3/4" NPT
- 0313 Tee, 3/4" brass
- 0318 Security clips (set of 5)

Other Parts (not illustrated)

- 0305 O-Ring, 18x3mm for supply/return
- 0306 Gasket, 17x24x2mm for gas connection pipe
- 0309 Accessory pack for coaxial venting fasteners
- 0312 Outdoor temperature sensor, NTC
- 0314 Air bleed key
- 0320 Technical Literature Set, Vitodens 222-F
- 0326 Parts List for Installation Set, top

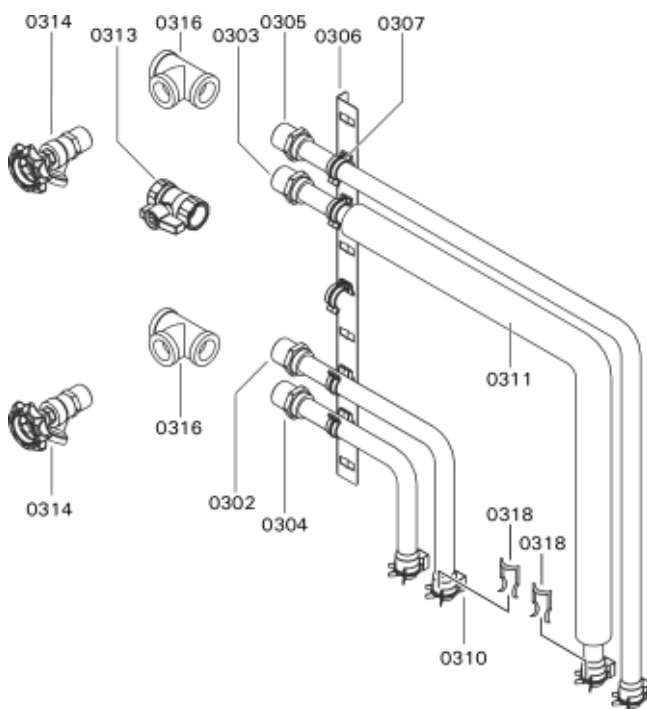

Parts for Left/Right Side Connection

- 0301 Flex pipe (NG/LP), full-length
- 0302 Connecting pipe 90°, DHW short
- 0303 Connecting pipe 90°, DHW long
- 0304 Connecting pipe 90°, heating short
- 0305 Connecting pipe 90°, heating long
- 0306 Support bracket with pipe clips
- 0307 Pipe clip (each)
- 0310 Connector retaining clip (Set of 2)
- 0311 Pipe insulation, 19x9x740mm
- 0313 Gas ball valve, 3/4" brass
- 0314 Sediment faucet, 3/4" NPT
- 0316 Tee, 3/4" brass
- 0318 Security clips (set of 5)

Other Parts (not illustrated)

- 0308 O-Ring, 18x3mm for supply/return
- 0309 Gasket, 17x24x2mm for gas connection pipe
- 0312 Accessory pack for coaxial venting fasteners
- 0315 Outdoor temperature sensor, NTC
- 0317 Air bleed key
- 0320 Technical Literature Set, Vitodens 222-F
- 0325 Parts List for Installation Set, left/right

Technical Data

Boiler Model No. 222-F B2TA		19	35
Natural Gas / Liquid Propane Gas CSA input	MBH (kW)	12-67 (3.5-20)	19-125 (5.5-37)
CSA output/DOE *1 heating capacity	MBH (kW)	10.9-61 (3.2-18)	17.4-114 (5.1-33)
Net AHRI rating *2	MBH	53	99
Heat exchanger surface area	ft. ² (m ²)	10.89 (1.01)	10.89 (1.01)
Min. gas supply pressure			
Natural gas	"w.c.	4	4
Liquid propane gas	"w.c.	10	10
Max. gas supply pressure *3			
Natural gas	"w.c.	14	14
Liquid propane gas	"w.c.	14	14
A.F.U.E.	%	93.3	93.3
Weight	lbs (kg)	282 (128)	282 (128)
Boiler water content	USG (L)	0.87 3.27	0.87 3.27
Boiler max. flow rate *4	GPM (L/h)	6.2 (1400)	6.2 (1400)
Expansion tank *5 (for heating system side)			
Precharge pressure	psig	12	12
Capacity	USG L	3.2 12	3.2 12
Max. operating pressure at 210° F (99° C)	psig (bar)	45 (3)	45 (3)
Boiler water temperature			
- Adjustable high limit (AHL) range space heating (steady state)	°F (°C)	68 to 165 (20 to 74)	68 to 165 (20 to 74)
- Fixed high limit (FHL)	°F (°C)	210 (99)	210 (99)
Boiler connections			
Boiler heating supply and return	NPTM"	3/4"	3/4"
Pressure relief valve	NPTF"	3/4"	3/4"
Drain valve	(male thread)	3/4"	3/4"
Boiler supply/return for indirect-fired DHW storage tank (field supplied)	NPT"	3/4"	3/4"
Gas valve connection	NPTF"	3/4"	3/4"

*1 Output based on 140° F (60° C), 120° F (49° C) system supply/return temperature.

*2 Net AHRI rating based on piping and pick-up allowance of 1.15.

*3 If the gas supply pressure exceeds the maximum gas supply pressure value, a separate gas pressure regulator must be installed upstream of the heating system.

*4 See "Typical System Flow Rates" starting on page 8 in this manual.

*5 Determine the required size of the expansion tank to be installed in the heating system. If the integral expansion tank is insufficient, install a suitably sized expansion tank on site.

Technical Data *(continued)*

Boiler Model No. 222-F B2TA		19	35
Dimensions			
Overall depth	inches (mm)	23½ (595)	23½ (595)
Overall width	inches (mm)	23⅝ (600)	23⅝ (600)
Overall height	inches (mm)	64 (1625)	64 (1625)
Flue gas *5			
Temperature (at boiler return temperature of 86° F (30° C))			
- at rated full load	°F (°C)	113 (45)	113 (45)
- at rated partial load	°F (°C)	95 (35)	95 (35)
Temperature (at boiler return temperature of 140° F (60° C))		154 (68)	154 (68)
Average condensate flow rate *6			
with natural gas and T _S /T _R = 122/86° F (50/30° C)		USG/h (L/h)	4-4.5 (15 - 17)
2.6-3.4 (10 - 12)			
Condensate connection *7			
hose nozzle Ø in.		¾-1"	¾-1"
Boiler flue gas connection *8			
Ø in. (mm)		2⅜" (60)	2⅜" (60)
Combustion air supply connection (coaxial)			
outer Ø in. (mm)		4" (100)	4" (100)
DHW storage tank			
DHW storage tank capacity	USG (L)	26.5 (100)	26.5 (100)
Temperature and pressure relief valve (factory installed)	psig/temp	150/210° F (99° C)	150/210° F (99° C)
Max. allowable operating pressure (DHW)	psig	150	150
Storage tank test pressure	psig	300	300
Continuous DHW output	MBH (kW)	61 (17.8)	114 (33.4)
Continuous DHW output draw rate *9	GPM (L/min.)	1.8 (6.6)	3.3 (12.3)
Max. DHW draw rate (over 10 min. period) *9	USG (L)	44 (166)	60 (227)

*5 Measured flue gas temperature with a combustion air temperature of 68° F (20° C).

*6 Based on typical boiler cycles, including partial load conditions.

*7 Requires 1 inch (25 mm) tubing. See the Installation Instructions of the Vitodens 222-F, B2TA for details.

*8 For side wall vent installations (coaxial system):

Do not exceed max. equivalent length specified in the Installation Instructions of the Vitodens 222-F, B2TA Venting System.

Do not attempt to common-vent Vitodens 222-F, B2TA with any other appliance.

Side wall coaxial vent installation must include Viessmann protective screen!

For details refer to the Installation Instructions for the Vitodens 222-F, B2TA Venting System.

*9 Based on a temperature rise of 70° F (21° C), 50° F to 120° F (10° C to 49° C).

For information regarding other Viessmann System Technology componentry, please reference documentation of respective product.

Note: For high altitude installation at 10,000 ft. (3050 m) the input for 222-F, B2TA 19 and 35 will have an altitude de-rating of 21%.

Maintenance Record

Measurements		Service date: by:	Service date: by:	Service date: by:	Service date: by:	Service date: by:	Service date: by:	Setpoint value
Static pressure	*w.c.							max. 14 *w.c.
Running pressure (supply pressure)								
<input type="checkbox"/> Natural gas	*w.c.							4-14 *w.c.
<input type="checkbox"/> LPG	*w.c.							10-14 *w.c.
<i>Check gas type</i>								
Carbon dioxide content CO₂								
■ at lower end of rated input range	vol.-%							
■ at upper end of rated input range	vol.-%							
Oxygen content O₂								
■ at lower end of rated input range	vol.-%							
■ at upper end of rated input range	vol.-%							
Carbon monoxide content CO								
■ at lower end of rated input range	ppm							50 ppm air-free*
■ at upper end of rated input range	ppm							
Ionization current	µA							

*Fuel type, altitude, venting and other site parameters may change

Lighting and Operating Instructions

FOR YOUR SAFETY READ BEFORE OPERATING

W A R N I N G: If you do not follow these instructions exactly, a fire or explosion may result causing property damage, personal injury or loss of life.

- A. This appliance does not have a pilot. It is equipped with an ignition device which automatically lights the burner. Do not try to light the burner by hand.
- B. **BEFORE OPERATING** smell all around the appliance area for gas. Be sure to smell next to the floor because some gas is heavier than air and will settle on the floor.
WHAT TO DO IF YOU SMELL GAS
 - Do not try to light any appliance.
 - Do not touch any electric switch; do not use any phone in your building.
 - Immediately call your gas supplier from a neighbor's phone. Follow the gas supplier's instructions.
 - If you cannot reach your gas supplier, call the fire department.
- C. Use only your hand to push in or turn the gas control knob. Never use tools. If the knob will not push in or turn by hand, don't try to repair it, call a qualified service technician. Force or attempted repair may result in a fire or explosion.
- D. Do not use this appliance if any part has been under water. Immediately call a qualified service technician to inspect the appliance and to replace any part of the control system and any gas control which has been under water.

OPERATING INSTRUCTIONS

1. **STOP!** Read the safety information above on this label.
2. Set thermostat or other operating control to lowest setting.
3. Turn off all electric power to the appliance.
4. This appliance is equipped with an ignition device which automatically lights the burner. Do not try to light the burner by hand.
5. Close main gas shut-off valve.
6. Wait five (5) minutes to clear out any gas. Then smell for gas, including near the floor. If you smell gas, **STOP!** Follow "B" in the safety information above on this label. If you don't smell gas, go to the next step.
7. Open main gas shut-off valve.
8. Turn on all electric power to the appliance.
9. Set thermostat or other operating control to desired setting.
10. If the appliance will not operate, follow the instructions "To Turn Off Gas To Appliance" and call your service technician or gas supplier.

Manual gas shutoff

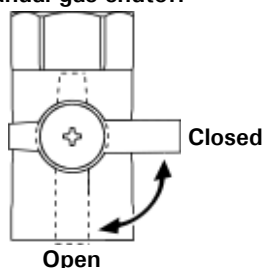

TO TURN OFF GAS TO APPLIANCE

1. Set thermostat or other operating control to lowest setting.
2. Turn off all electric power to the appliance if service is to be performed.
3. Close main gas shut-off valve.

Quick Reference

°C	°F
-40	-40
-35	-31
-25	-13
-20	-4
-18	0
-16	+3
-14	+7
-12	+10
-10	+14
-9	+16
-8	+18
-7	+19
-6	+21
-5	+23
-4	+25
-3	+27
-2	+28
-1	+30
0	+32
+1	+34
+2	+36
+3	+37
+4	+39
+5	+41
+6	+43
+7	+45
+8	+46
+9	+48
+10	+50
+12	+54
+14	+57
+16	+61
+18	+64
+20	+68
+25	+77
+30	+86
+35	+95
+40	+104
+50	+122
+60	+140
+70	+158
+80	+176
+90	+194
+100	+212
+110	+230

Viessmann Manufacturing Company Inc.

750 McMurray Road

Waterloo, Ontario • N2V 2G5 • Canada

Technifo Line 1-888-484-8643

1-800-387-7373 • Fax (519) 885-0887

www.viessmann.ca • info@viessmann.ca

Viessmann Manufacturing Company (U.S.) Inc.

45 Access Road

Warwick, Rhode Island • 02886 • USA

Technifo Line 1-888-484-8643

1-800-288-0667 • Fax (401) 732-0590

www.viessmann-us.com • info@viessmann-us.com

