

# VITOSOL

Solar hot water heating systems  
Flat plate and vacuum tube solar collectors

**VIESSMANN**

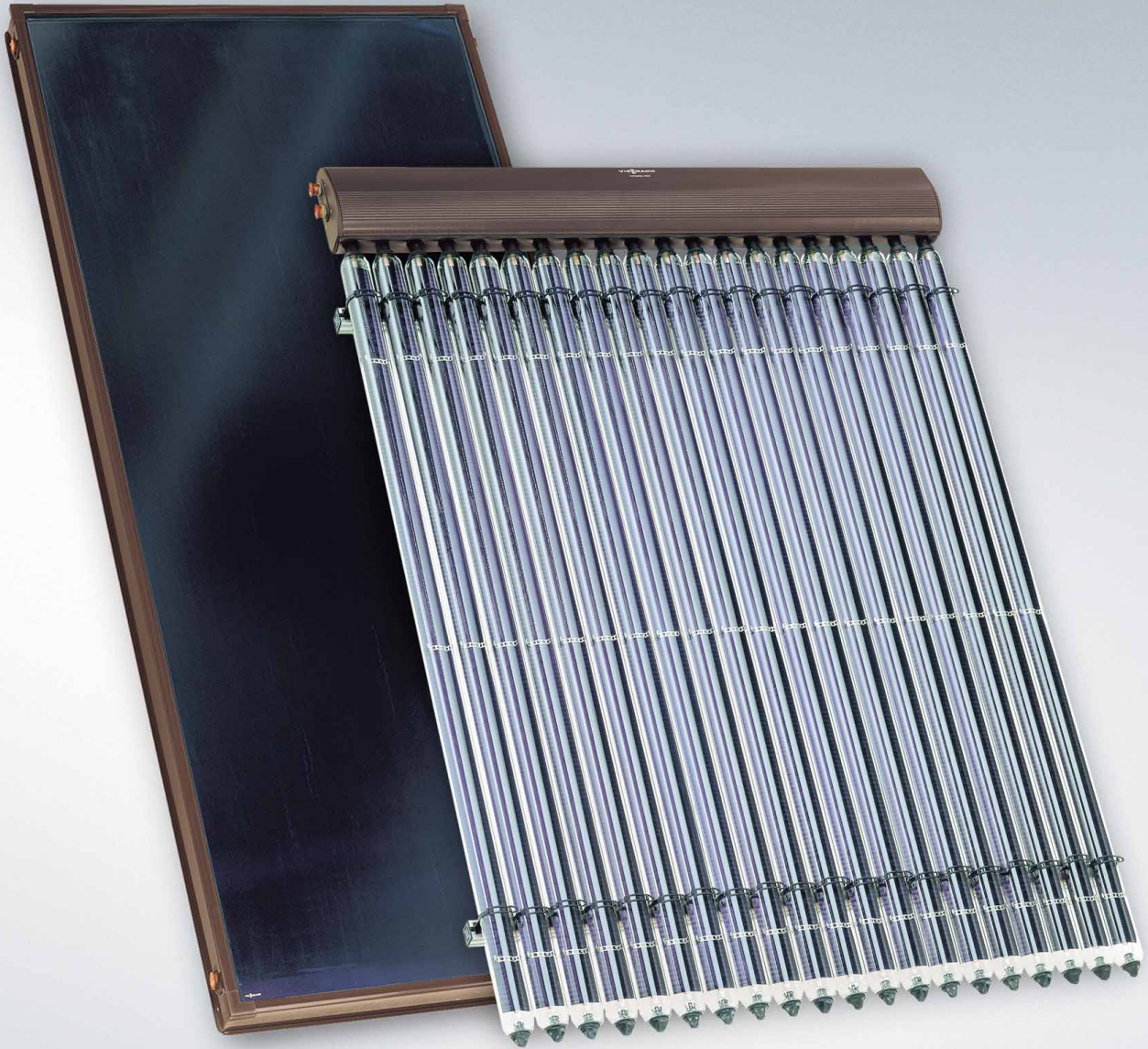



Solar energy can account for up to 70% or more of the energy required to heat the domestic hot water of an average family household.

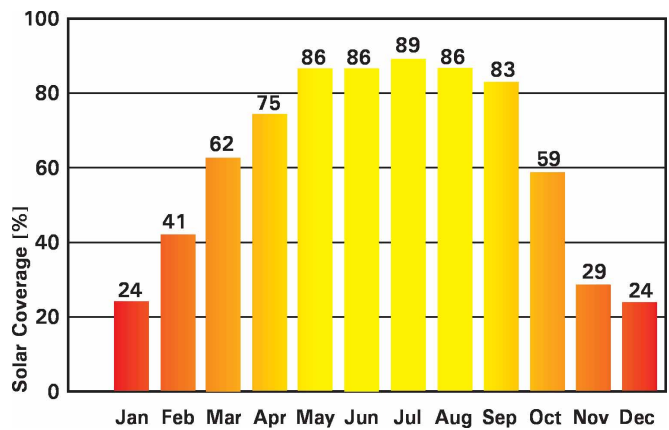

Based on typical northeastern location.  
Solar coverage can be significantly higher in many locations.

# Solar Energy: Energy on the House

Solar energy is free and can be harvested effectively in climates like ours. With a solar system from Viessmann, with highly-efficient collectors and matching system components, even the smallest amount of solar radiation can be used effectively. Viessmann solar collectors are specifically designed for northern climates, and can produce enough solar energy to heat as much as 70% of the annual hot water requirements of an average family household.\*

During the summer months a high-performance solar system covers almost all the energy required to heat your domestic hot water, reducing your oil, gas or electricity consumption and making you less dependent on fossil fuels. In the transitional months, solar energy is generally best used to preheat domestic hot water.

Viessmann solar collectors can also be used to supplement space heating or pool heating applications.

## Good for the environment

A solar system can make a real difference. Not just by reducing the energy bill, but by reducing harmful greenhouse gas emissions as well. A solar system can lower the average carbon dioxide (CO<sub>2</sub>) production of a standard North American household by  $\frac{3}{4}$  of a tonne a year.\*

## Built for the future

Viessmann solar collectors are built on more than 30 years of experience. And like other Viessmann products, all Viessmann solar products are constructed using the highest-quality, corrosion- and UV-resistant materials, such as powder-coated aluminum, copper and stainless steel. Viessmann Vitosol collectors are performance tested in Europe, and in North America by the Solar Rating and Certification Corporation (SRCC) and are designed to produce a consistently high thermal output for a period of more than 20 years.

## A smart choice

An investment in a renewable energy system, like solar, not only reduces the day-to-day operating cost, but is also frequently subsidized by different levels of government. Both in the U.S. and Canada, an increasing number of incentive programs are offered by federal, state or provincial governments.

Viessmann solar collectors are OG100 certified and are eligible for many of these incentive programs. For more information on current incentive programs in your area, please contact your local Viessmann Sales Representative.

## Viessmann Solar

At Viessmann we are committed to environmentally-friendly manufacturing processes and green heating solutions. Our solar heating products are the result of more than 30 years of experience. More than 2 million Viessmann solar collectors have been installed in Germany alone. With a Viessmann solar system you are making an investment for the future. Not only because you are preserving valuable fossil fuels and reducing emissions, but also because Viessmann solar collectors, like all of our products, are highly efficient, long-lasting and of quality construction.

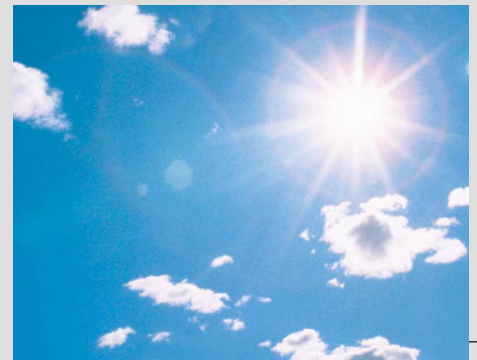

\* Based on a 2-collector system package in a northeastern location.



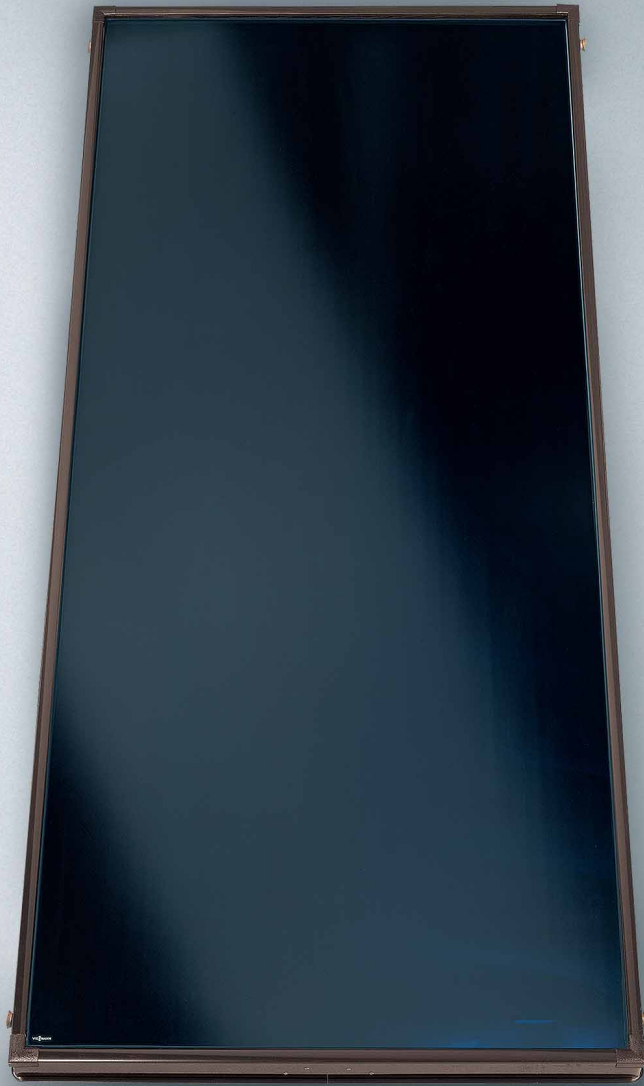

Vitosol 100 –  
flat plate solar  
collectors

# High Performance, Attractive Price

The low investment cost, combined with the high-efficiency operation of the Vitosol 100 flat plate solar collector, speaks for itself.

Constructed by Viessmann with highest-quality materials, the Vitosol 100 provides consistently high performance over a long service life. And the new and improved design and lightweight construction make this collector even more installation-friendly.

## Lasting performance

A highly-selective Sol-Titanium coated copper absorber and extremely effective insulation ensure solar energy is harvested efficiently. Corrosion-resistant materials, such as aluminum, copper and stainless steel, as well as 3.2 mm special hail-proof solar glass, guarantee reliable operation for more than 20 years.

## Easy installation

The Vitosol 100 is extremely easy to install. Its lightweight design (only 45 kg / 99 lbs) makes for easy transportation onto the roof, and flexible connection pipes allow for fast assembly and installation. Up to 12 collectors can be installed in series. Durable mounting hardware ensures solid connection to flat or sloped roofs.



Faster installation with flexible connection pipes

## Universal application

With an absorber surface area of 2.3 m<sup>2</sup>/25 ft.<sup>2</sup> Vitosol 100 flat plate collectors can be adapted to fit virtually any requirement. Two different models allow for horizontal (model SH1) or vertical (model SV1) installation on flat and sloped roofs, or as a free-standing installation. Vitosol 100 flat plate collectors are great for domestic hot water heating, pool heating or as a space heating supplement.

## Attractive design

The clean and aesthetic design of the Vitosol 100 collectors make them an unobtrusive, attractive addition to any roof.

- High performance at an **attractive price**.
- **Optimized collection of solar energy** thanks to the highly-efficient Sol-Titanium coated copper absorber and extremely effective insulation.
- **Durable, corrosion-resistant** construction using quality materials such as powder-coated aluminum, copper and stainless steel, as well as 3.2 mm special low-iron solar glass and non-degrading thermal insulation.
- **Universal application:** on flat or sloped roofs, or as free-standing installation. Compatible with any type of DHW heating system.
- Flexible connection pipes facilitate **short installation times**. Up to 12 collectors can be installed in series using a **convenient plug-in system**.
- Part of a **fully integrated system package** available from Viessmann.
- **Certified** by the Solar Rating and Certification Corporation (SRCC).

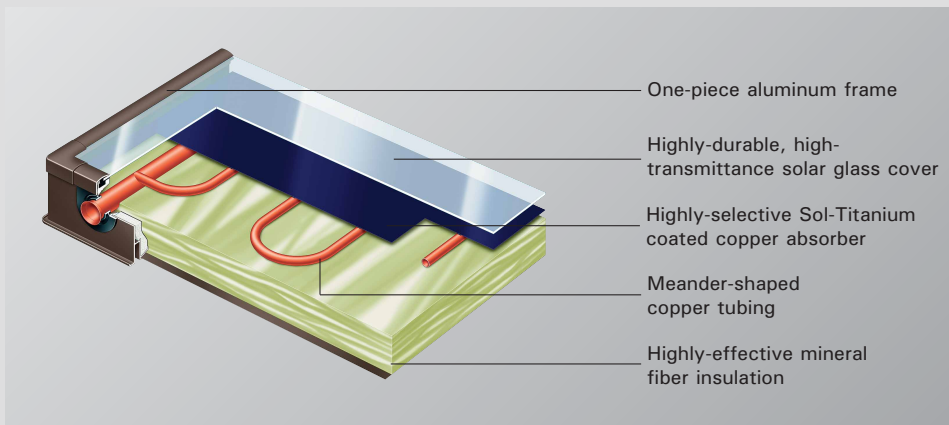



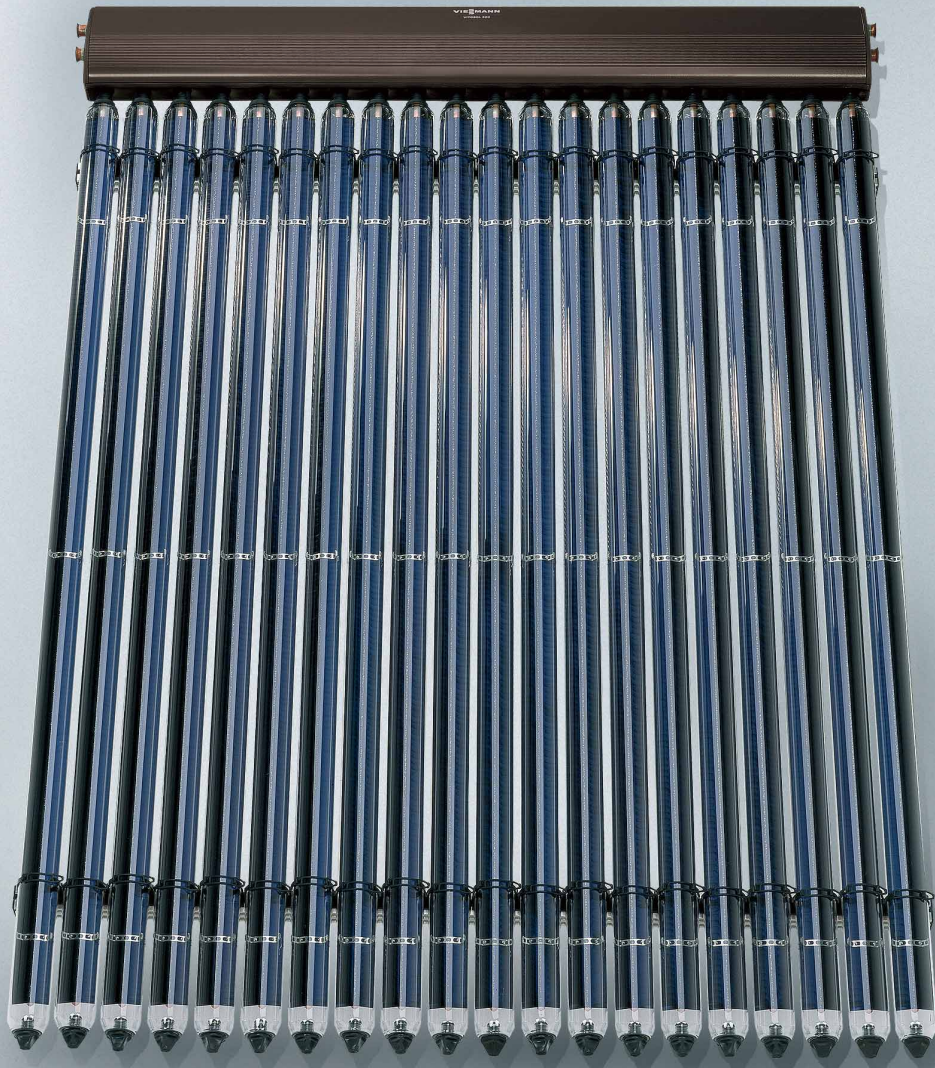

Vitosol 300 –  
vacuum tube solar  
collectors

# Exceptional Performance, Advanced Design

The Vitosol 300 is a vacuum tube solar collector with exceptional year-round performance. Due to the insulating qualities of the vacuum tubes, this collector provides excellent results especially in cold weather and windy conditions. The integrated stagnation protection also makes it your best choice for a space heating supplement system.

## Principle of operation

The Vitosol 300 operates based on the heat pipe principle. Solar energy is captured by the Sol-Titanium coated copper absorber in the vacuum tubes of the collector. The energy is then transported via the heat pipe to the double-pipe heat exchanger where it is transferred to the solar fluid. The fluid then circulates the solar energy to your domestic hot water storage tank.

## Patented Duotec heat exchanger

The unique Duotec double-pipe heat exchanger of the collector almost completely surrounds the heat pipe condenser tip, ensuring the best possible heat transfer. A "dry" connection (i.e. without direct contact to the solar fluid) transfers the solar energy from the heat pipe to the solar fluid. This of course not only simplifies the installation process, but makes for easy replacement of individual tubes - even when the system is filled and under pressure.

## Easy installation and maintenance

During installation, collectors are easily connected in series with flexible connection pipes and quick-connect fittings. And thanks to the "dry" connection between heat pipe and solar fluid, individual vacuum tubes are easy to replace. Each vacuum tube can also be rotated for optimal alignment to the sun.

## No overheating

A challenge for any solar system is periods of sunshine with no heat consumption - so-called stagnation periods. The Vitosol 300 collector comes with an integrated temperature limiting thermal valve in the condenser tip that prevents the system fluid from overheating during stagnation periods.

## High-quality construction

High-quality, corrosion-resistant materials, such as special hail-proof solar glass, powder-coated aluminum, copper and stainless steel, guarantee reliable and efficient operation on a consistently high level for as long as 20 years or more.

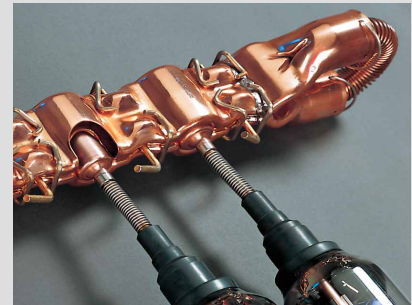

The Duotec double-pipe heat exchanger

- **High-efficiency collection of solar energy** thanks to the heat pipe design, Sol-Titanium coated copper absorber and vacuum sealed glass tubes.
- **Intensive heat transfer** from the condenser to the solar fluid is provided by the Duotec wrap-around pipe heat exchanger.
- A temperature limiting thermal valve in the condenser tip **prevents the system fluid from overheating** during stagnation periods.
- **Long service life and reliability** thanks to the use of durable, corrosion-resistant materials such as copper, impact-resistant solar glass and flexible stainless steel.
- **Short installation times** with flexible connection pipes, dry connection of the collector tubes to the heat exchanger, and quick-connect fittings and mounting hardware.
- **Universal application** for flat and sloped roofs, or as a free-standing installation.
- Part of a **fully integrated system package** available from Viessmann.
- **Certified** by the Solar Rating and Certification Corporation (SRCC).

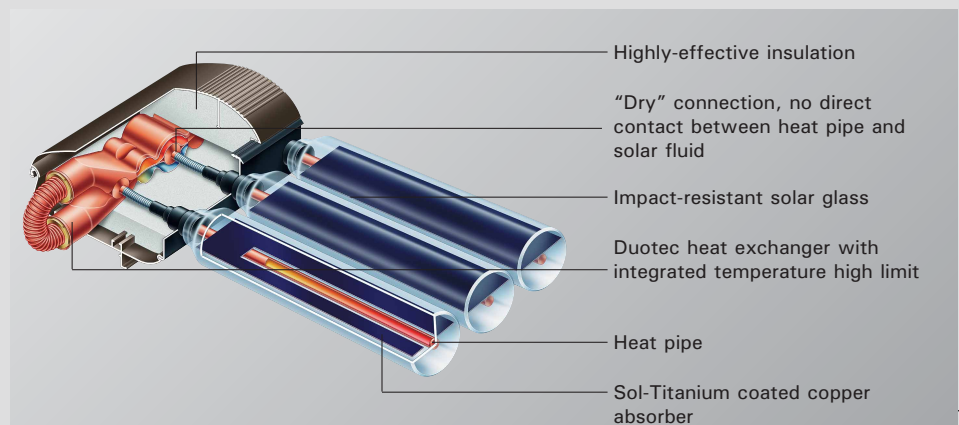



# Comfort and Savings All in One System

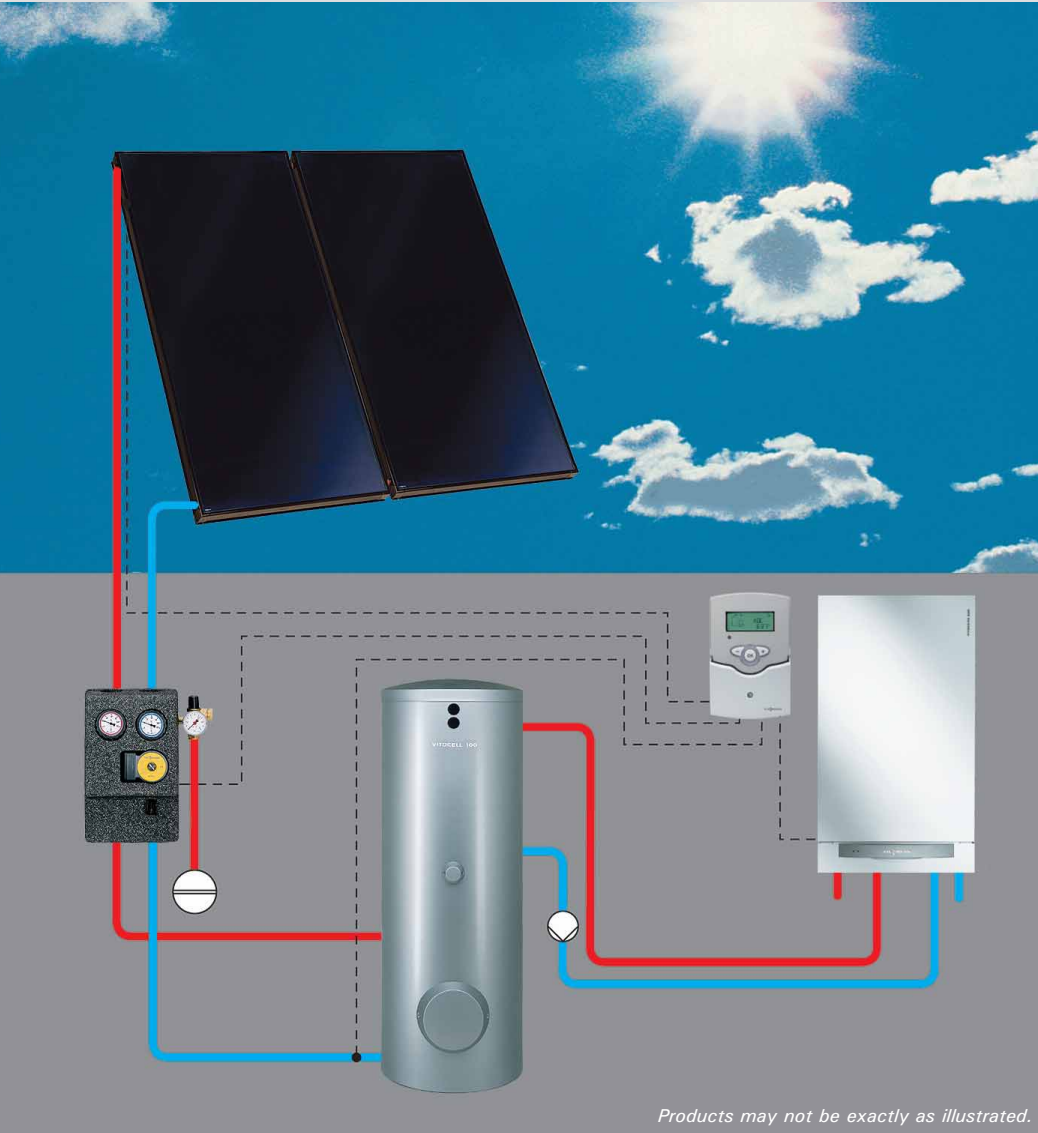

Products may not be exactly as illustrated.

## One source. One system.

Viessmann offers a complete line of high-quality flat plate and vacuum tube solar collectors, as well as system components, such as stainless steel storage tanks, system controls, innovative mounting hardware and pre-assembled pumping stations - all designed and manufactured by Viessmann to integrate seamlessly.

This complete system approach - with all components conveniently from one manufacturer, designed to match perfectly - not only saves time in the planning and installation phase, but provides maximum system reliability and performance.

For additional energy savings, Viessmann solar systems also integrate easily with our boiler technology or any domestic hot water heating system.

## Integrating a solar system

There are two primary ways of integrating a solar system, depending on the configuration of your domestic hot water heating system:

### 1. Solar retrofit preheat systems

With a solar retrofit preheat system, solar is easily integrated into virtually any existing domestic hot water heating system. This system uses a single-coil solar tank connected to the collectors. The collectors preheat the water in the solar tank, which is then fed into the existing hot water tank or instantaneous hot water heater.



Vitocell 100 and 300 domestic hot water storage tanks



Single-coil DHW storage tank  
Vitocell-V 300 (53-120 USG / 200-450 ltr)



## 2. Single-tank systems

When integrating solar into a new home, for example, a single-tank system is typically used. This system employs a dual-coil tank where heat from the solar collector(s) is transferred to the domestic hot water via the lower coil, and backup heat is supplied as required by a boiler via the upper coil.

### Domestic hot water (DHW) tanks

For both system configurations, Viessmann offers high-quality domestic hot water storage tanks:

#### *Vitocell 300 series tanks*

High-performance stainless steel tanks with lifetime warranty.\*  
42-120 USG / 160-450 ltr.

#### *Vitocell 100 series tanks*

A cost-efficient alternative, steel construction, two-coat enamel finish and magnesium anode for additional corrosion protection.  
42-120 USG / 160-450 ltr.

### Intelligent energy management

Two types of solar controls are available to satisfy the needs of any solar hot water heating system. The powerful Vitosolic 200 solar control offers complete energy management for maximum system performance. With 4 temperature differentials, 4 pump outputs, digital temperature displays and more, the Vitosolic 200 can be used for all common solar heating systems. For basic solar hot water heating systems, Viessmann offers the cost-effective GL30 solar control unit.

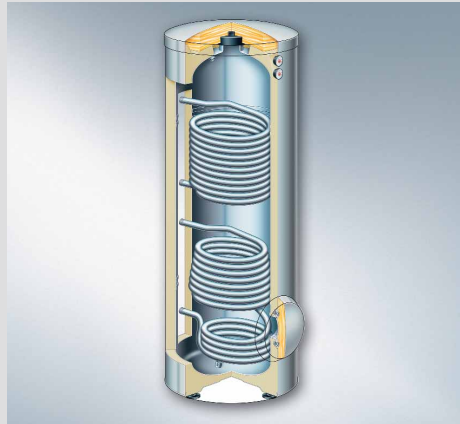

Dual-coil DHW storage tank  
Vitocell-B 300



Solar-Divicon pre-assembled  
pumping station

### Vitosolic 200

- **Universal** electronic differential temperature control for multi-function (up to 4 consumers) solar hot water heating systems.
- **Powerful** control capability with up to 6 sensor inputs and 4 pump outputs.
- **Easy-to-use** interface technology based on Vitotronic control principles.
- **Convenient** four-line plain text display for current temperature information and pump operating status.
- **Ideal** for demanding solar applications: multi-tank installations, pool heating, space heating backup.

### Solar-Divicon pumping station

The Solar-Divicon pumping station comes pre-assembled and handles all hydraulic functions and thermal protection of your solar system. All necessary safety and functional modules - such as system pump, flow check valve, flow meter, pressure gage, air separator and fill valves - are combined in this compact and reliable assembly.



Intelligent solar energy management with  
Vitosolic 200

\* In residential applications.

# The Vitosol Line at a Glance

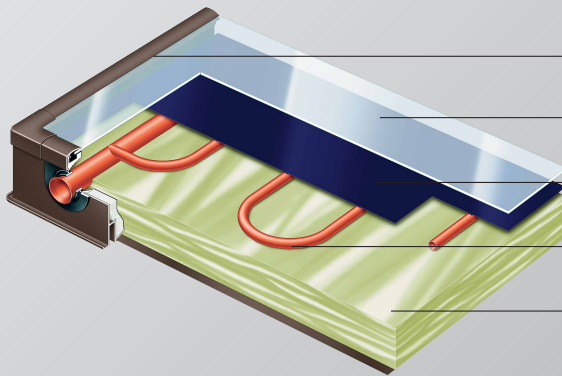

- One-piece aluminum frame
- Highly-durable, high-transmittance solar glass cover
- Highly-selective Sol-Titanium coated copper absorber
- Meander-shaped copper tubing
- Highly-effective mineral fiber insulation

## VITOSOL 100

Flat plate solar collector with Sol-Titanium coated copper absorber

Model		SV1*	SH1**
<b>Total surface area</b>	ft. <sup>2</sup> / m <sup>2</sup>	27.2 / 2.53	27.2 / 2.53
<b>Absorber surface area</b>	ft. <sup>2</sup> / m <sup>2</sup>	24.8 / 2.30	24.8 / 2.30
<b>Aperture area***</b>	ft. <sup>2</sup> / m <sup>2</sup>	25.0 / 2.32	25.0 / 2.32
<b>Total dimensions</b>	Width in / mm	41 3/4 / 1061	94 / 2385
	Height in / mm	94 / 2385	41 3/4 / 1061
	Depth in / mm	3 1/2 / 90	3 1/2 / 90
<b>Weight (incl. insulation)</b>	lbs / kg	99 / 45	99 / 45

\* vertical installation

\*\* horizontal installation

\*\*\* for sizing purposes

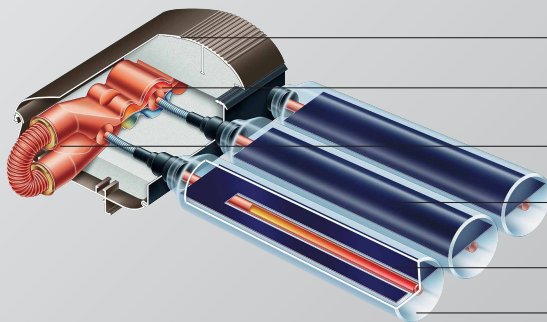

- Highly-effective insulation
- "Dry" connection, no direct contact between heat pipe and solar fluid
- Duotec heat exchanger with integrated temperature high limit
- Sol-Titanium coated copper absorber
- Heat pipe
- Impact-resistant solar glass

## VITOSOL 300

Vacuum tube solar collector with Sol-Titanium coated copper absorber using the heat pipe principle

Model		SP3	SP3
<b>No. of tubes</b>		20	30
<b>Gross area</b>	ft. <sup>2</sup> / m <sup>2</sup>	30.5 / 2.83	45.6 / 4.24
<b>Absorber surface area</b>	ft. <sup>2</sup> / m <sup>2</sup>	22 / 2.05	33 / 3.07
<b>Aperture area*</b>	ft. <sup>2</sup> / m <sup>2</sup>	22.7 / 2.11	34.1 / 3.17
<b>Total dimensions</b>	Width in / mm	55 3/4 / 1419	83 3/4 / 2126
	Height in / mm	78 1/2 / 1996	78 1/2 / 1996
	Depth in / mm	4 3/4 / 122	4 3/4 / 122
<b>Weight (incl. insulation)</b>	lbs / kg	99 / 45	150 / 68

\* for sizing purposes









# Choosing Your Collector

## Which collector is right for me?

When choosing a solar collector, considering the following factors can help you choose the collector system best suited to your needs:

- Type of application
- Solar coverage rate\*
- Available roof space
- Available budget

All Viessmann collectors can be used in any application. To ensure maximum performance, Viessmann recommends the use of specific collectors for certain applications based on the fluid temperature requirement of the application and the heat loss characteristics of the collector.

Type of Application	VITOSOL 100	VITOSOL 300
Domestic hot water system with low solar coverage*		
Domestic hot water system with high solar coverage*		
Pool heating system		
Combination DHW and space heating system		
Process heating and solar air conditioning system		



Best choice



Recommended if roof space is limited.



Budget-friendly, lower-performance option.

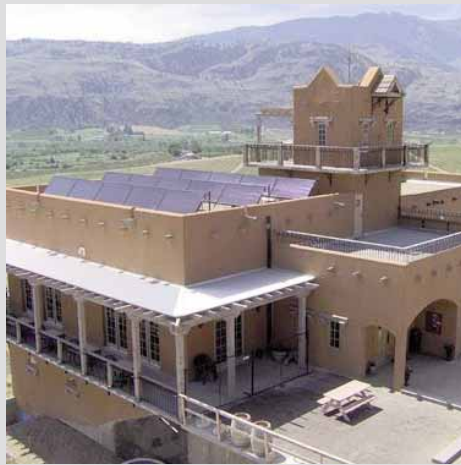

\* Percentage of energy covered by solar system. Low: 40 - 60%, typical commercial application. High: 60 - 80%, typical residential application.





## Viessmann

With more than 7,000 employees around the world, the Viessmann Group is one of the leading manufacturers of heating technology worldwide. Viessmann represents competence and innovation and offers you a wide variety of high-tech heating products, each a design-matched component in the progressive Viessmann system technology. Despite their diversity, Viessmann products have one thing in common: a high standard of quality throughout the entire product line that translates into operational reliability, energy savings, environmental friendliness and operational comfort.

Viessmann innovations lead the industry not only in conventional heating technology, but also in the area of renewable energy sources such as solar and heat pump technology.

All of our products are developed in accordance with our philosophy to achieve the greatest value at all times – for our customers and our business partners.

Contact the Viessmann office in Canada or U.S.A. for the name of the Viessmann Sales Representative closest to you.

**North American and Canadian Head Office**  
 Viessmann Manufacturing Company Inc.  
 Waterloo, ON Canada  
 Tel. (519) 885-6300  
 Fax (519) 885-0887  
[www.viessmann.ca](http://www.viessmann.ca)

**U.S. Head Office**  
 Viessmann Manufacturing Company (U.S.) Inc.  
 Warwick, RI U.S.A.  
 Tel. (401) 732-0667  
 Fax (401) 732-0590  
[www.viessmann-us.com](http://www.viessmann-us.com)

**Viessmann Sales Center**  
 Langley, BC Canada (604) 533-9445

**Viessmann Sales Offices**  
 Waterloo, ON Canada (226) 338-7038  
 Toronto, ON Canada (416) 657-4333  
 Stoney Creek, ON Canada (905) 664-4426  
 Reno, NV U.S.A. (775) 849-0725



Viessmann meets all your heating needs with a diverse, yet completely harmonized product range.

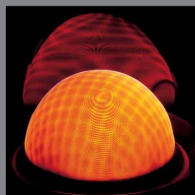

Certified Climate Protection