

LANCASTER®
WATER TREATMENT

INSTALLATION, OPERATING
AND SERVICE MANUAL

ELECTRONIC WATER SOFTENER
WITH THE 2000S
SUPER VALVE

7-LECS-75

7-LES-75

7-LES-100

7-LES-150

7-LES-200

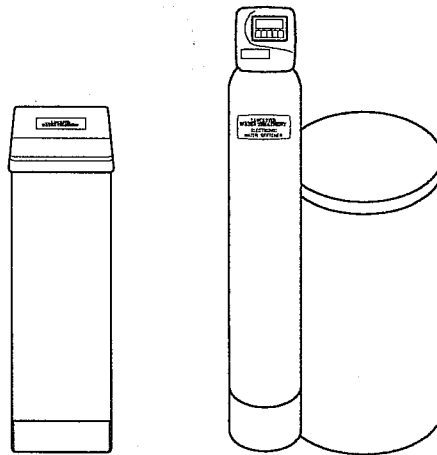

Congratulations on purchasing your new Lancaster Water Softener. This unit is designed to give you many years of trouble free service. When installed in accordance with the following instructions and if given reasonable care, clear-soft water will be the result. For servicing and future inspection purposes, please file this booklet with your important documents.

OPERATING PARAMETERS

Minimum / Maximum Operating Pressures	20 psi (138 kPa) - 125 psi (862 kPa)
Minimum / Maximum Operating Temperatures	40°F (4°C) - 110°F (38°C)
Supply Voltage/ Frequency	120V AC/ 60 Hz Other Options Available
Power Consumption	9.5 W
Output Voltage	12V AC
Output Current	500 mA

GENERAL WARNINGS

The control valve, fittings and/or bypass are designed to accommodate minor plumbing misalignments but are not designed to support the weight of a system or the plumbing.

Do not use Vaseline, oils, other hydrocarbon lubrications or spray silicone anywhere. A silicone lubricant may be used on black o-rings but is not necessary. **Avoid any type of lubricants, including silicone, on red or clear lip seals.**

The nuts and caps are designed to be unscrewed or tightened by hand or with the special plastic wrench (P/N V3193). If necessary, pliers can be used to unscrew the nut or cap. Do not use a pipe wrench to tighten or loosen nuts or caps. Do not place screwdriver in slots on caps and/or tap with hammer.

Do not use pipe dope or any other sealant on threads. Teflon tape **must** be used on the threads of the 1" NPT elbow or the 1/4" NPT connection and on the threads for the drain line connection. Teflon tape is not necessary on the nut connection or caps because of o-ring seals.

After completing any valve maintenance involving the drive assembly and pistons, press and hold **NEXT** and **REGEN** button for three seconds or unplug power source jack from printed circuit board (black wire) and plug back in. This resets the electronics and establishes the service piston position. The display should flash all wording, then flash software version (e.g. 154) and then reset the valve to the service position.

All plumbing should be done in accordance with local plumbing codes. The pipe size of the drain line should be a minimum of 1/2". Backwash flow rates in excess of 7 gpm or length in excess of 20' require 3/4" drain line.

Solder joints near the drain must be done prior to connecting the drain line flow control fitting. Leave at least 6" between the drain line control fitting and solder joints when soldering pipes that are connected on the drain line control fitting. **Failure to do this could cause interior damage to the drain line flow control fitting.**

When assembling the installation fitting package(P/N V3007) to the inlet and outlet (see Page 7), connect the fitting to the plumbing system first and then attach the nut, split ring and o-ring. Heat from soldering or solvent cements may damage the nut, split ring or o-ring. Solder joints should be cool and solvent cements should be set before installing the nut, split ring and o-ring. **Avoid getting primer and solvent cement on any part of the o-rings, split rings, bypass valve or control valve.**

Plug into an electrical outlet. **NOTE:** All electrical connections must be connected according to local codes. (Be certain the outlet is uninterrupted.) Install grounding strap on metal pipes.

INSTALLATION

Place softener in desired location close to water supply inlet, after pressure tank, and near a source for waste water, (utility sink, floor drain or sewer line). A 115/120V, 60 Hz uninterrupted outlet is required. Keep softener far enough away from walls and other obstructions to allow enough room for servicing the unit. All sillcocks and similar fixtures that will use untreated water must have their pipes connected to the hard water side of the softener. A bypass valve (optional accessory) should be installed so that water will be available if it should be necessary to shut off the pressure in order to service the softener.

The cabinet tank or mineral tank must be reasonably level and solidly in place. Prior to beginning work to the system, make sure that water pressure is shut off at the incoming water supply and that several water spigots are open to provide sufficient venting for drainage of that system.

Arrows are molded into the control valve to show the direction of the flow.

OPTIONAL BYPASS VALVE: The bypass valve easily connects to the control valve body using nuts that only require hand tightening. Install with red knobs in the upward position. Press end of bypass valve with o-rings into valve. Hand tighten nuts. Place into **BYPASS OPERATION (figure 1 page 3)**.

Avoid getting primer and solvent cement on any part of the o-rings or split rings, bypass valve or control valve. **DO NOT** use pipe dope or any other sealant on threads. Teflon tape is not necessary on the caps because of o-ring seals. Do not use Vaseline or other unacceptable lubricants on o-rings. A silicone lubricant may be used on black o-rings.

DRAIN LINE: The 3/4" drain line elbow accommodates 5/8" poly tube or 3/4" NPT drain line connections. The nut and poly tube insert for the 3/4" drain line elbow is designed for use with flexible poly tube only. The drain line elbow can be rotated so the outlet can be oriented toward the nearest drain.

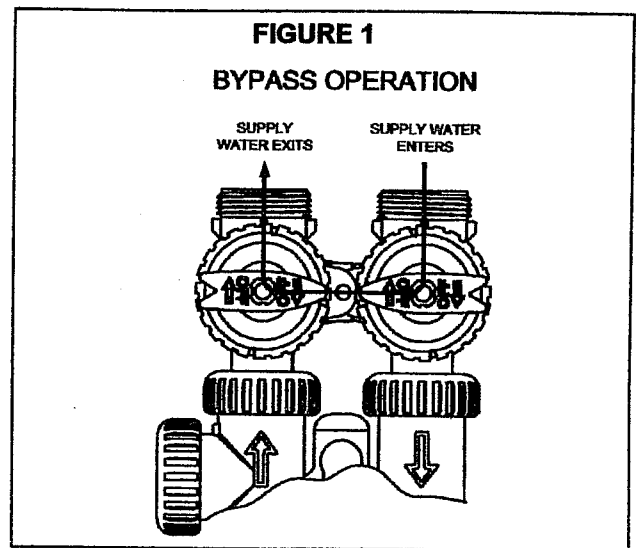
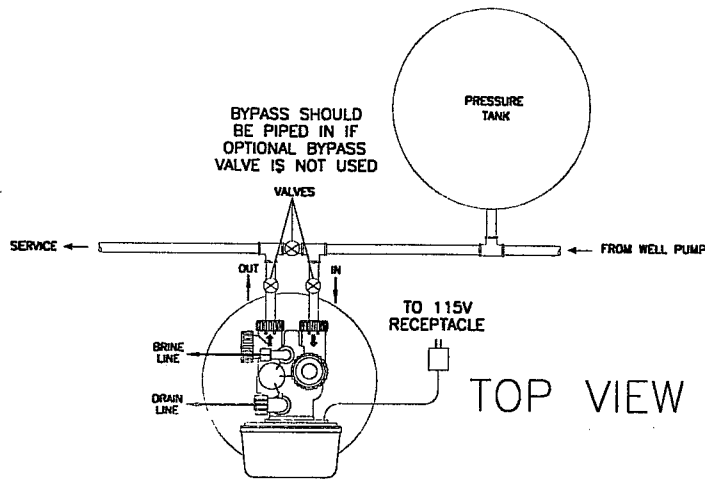

TO INSTALL 5/8" POLY TUBE DRAIN LINE: The poly tube insert is shipped attached to the drain line elbow's locking clip. Press the insert into the drain line (5/8" poly tube not included). Loosen nut of the drain line elbow. Press 5/8" poly tube with insert into the drain line elbow until it seats on the back of the fitting. Tighten nut.

It is simplest to run the drain line into a sump pump pit or washing machine drain if possible. If this is not practical, a fitting with a trap must be installed in a sewer line. Place the trap as close to the vent as possible to prevent siphoning of the trap when large amounts of waste water go through the sewer line. **DO NOT** pipe the drain line solidly into the waste line, as this is prohibited by most plumbing codes. The drain line should enter the trap from above so the water will not back up in the drain line if sewer should become plugged up and the trap overflow. The trap should have a short pipe extending from it to prevent splashing when water runs into the trap from drain line.

BRINE LINE CONNECTIONS: 3/8" poly tube is shipped within the instruction/warranty card packet affixed to the control valve. The poly tube inserts are shipped on the brine line elbow's locking clip. Remove the locking clip by pulling straight out. Remove the white poly tube insert from the locking clip, and replace the locking clip on the brine line elbow of the control valve.

Press the poly tube insert into the provided 3/8" poly tube. Press the poly tube and insert into the nut until it is fully seated into the fitting. Do not use pipe dope or any other sealant on threads. Teflon tape is not needed on the threads. Tighten nut securely to create a pressure tight connection. Pliers or crescent wrench may be used. The nut, gripper and retainer sleeve is a three piece assembly that can come apart if removed from the elbow body. Parts must be reassembled exactly as shown to function properly. If the nut is completely removed from the body, slip the nut, plastic gripper and retainer sleeve on to the tube then tighten on to the fitting.

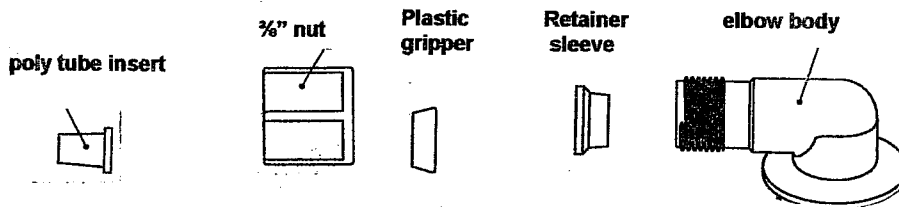

Install poly tube insert into the end of the 3/8" poly tube and repeat instructions above to install into the brine tank's brine line fitting.

BRINE TANK OVERFLOW PRECAUTION: Attach a 1/2" poly tube (not provided) to the barbed fitting on the outside of the tank. This poly tube should be piped to drain to allow brine to discharge to drain in the event of an overflow condition.

PROGRAMMING THE CONTROL VALVE: Note: A quick-reference card is stored inside the front cover of the control valve. To access this card, slightly pull tabs on side of cover outward and pull cover forward. Plug the electrical cord into a 115 Volt receptacle. **DO NOT** plug into an outlet controlled by a wall switch or pull chain that could inadvertently be turned off. Wait a couple of seconds for control valve to "home" itself. Panel should display "TIME" and the time of day will be flashing.

SET TIME OF DAY

STEP 1: Press SET CLOCK.

STEP 2: Set current hour of the day by pressing ▲ or ▼ buttons. AM/ PM toggles after 12.

STEP 3: Press NEXT. Set current minutes by pressing ▲ or ▼ buttons.

STEP 4: Press NEXT to exit SET CLOCK.

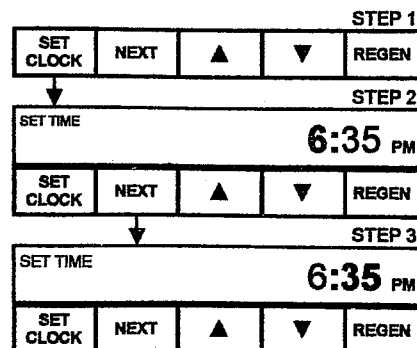

**ADDITIONAL PROGRAMMING INFORMATION AVAILABLE FROM
LANCASTER WATER TREATMENT UPON REQUEST.**

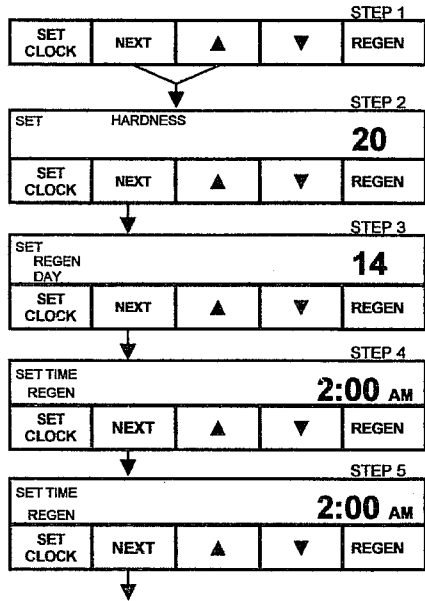

SET HARDNESS, DAYS OVERRIDE & REGENERATION TIME

- STEP 1: Press **NEXT** and **▲** simultaneously for 3 seconds.
- STEP 2: **Hardness**: Set the amount of hardness in grains of hardness as calcium carbonate per gallon using the **▲** or **▼** buttons. The default is 20. The available range is 1 to 150 in 1 grain increments.
- STEP 3: Press **NEXT**. **Regen day**: This sets the maximum number of days between regenerations. This days override feature can be shut off by pressing the **▼** button until "OFF" appears. Set the maximum number of days between by pressing **▲** or **▼**. Range is 1– 28 days. If the OFF position is selected, the softener will regenerate based solely on the gallons capacity.
- STEP 4: Press **NEXT**. **Regeneration time (hour)**: Set the hour of the day for regeneration to occur by using **▲** or **▼** buttons. AM/ PM toggles after 12. The default time is 2:00 am.
- STEP 5: Press **NEXT**. **Regeneration time (minutes)**: Set the minutes of the day for regeneration by using **▲** or **▼** buttons. Press **NEXT** to exit Displays/Settings. Current time of day will be displayed.

PLACING UNIT INTO SERVICE: Make sure inlet and outlet valves are to their closed positions. If using optional bypass, place in bypass position. Turn on main water supply. Open a cold water faucet. This will clear the lines of any debris (solder, pipe dope, etc.) that may be in the line. Let water run at tap for a couple of minutes, or until clear. Turn off faucet. Manually add 1½ gallons of water to the brine tank.

- Press and hold the **REGEN** button for approximately 5 seconds until the motor starts.
- Wait until display reads **BACKWASH** and numbers start counting down.
- Momentarily press **REGEN** again. Wait until display reads **BRINE** and numbers start counting down.
- Momentarily press **REGEN** again. Valve is now in the second **BACKWASH** position.

If using optional bypass **SLOWLY** turn bypass valve to **DIAGNOSTIC** position (figure 2) or slowly open inlet valve to allow water to slowly enter the softener.

When water is flowing steadily to drain without the presence of air, momentarily press **REGEN** again. Display will read **RINSE**.

Open the outlet valve of the softener, or if using optional bypass place to **NORMAL OPERATION MODE** (figure 3).

Allow control to finish the **RINSE** cycle. It will then advance to the **FILL** position. The brine tank will now automatically fill with the proper volume of water for the first regeneration.

Allow the control to automatically advance to the **SOFTENING** position.

Load the brine tank with salt. Solar Salt is recommended.

SANITIZING: Use 2 oz. of 5¼% household chlorine bleach for each cubic foot of resin. Pour bleach directly into the brine well of the softener. Press and hold the **REGEN** button for 5 – 6 seconds until the motor starts running. Allow system to complete the regeneration automatically. Check for other local and state codes which may also specify sanitation methods.

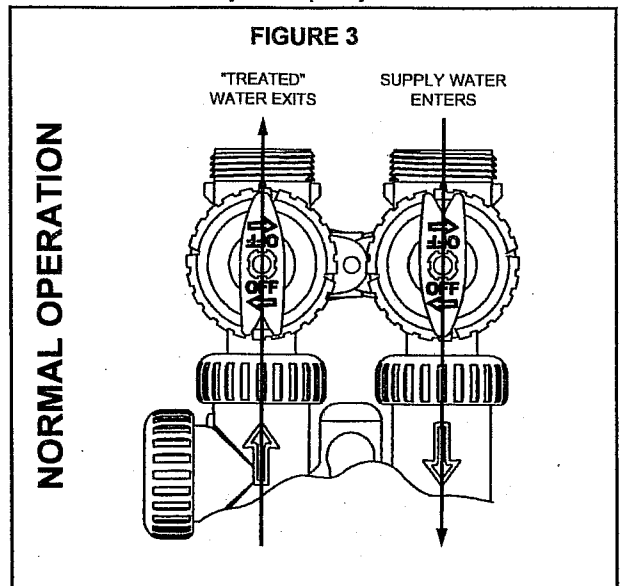
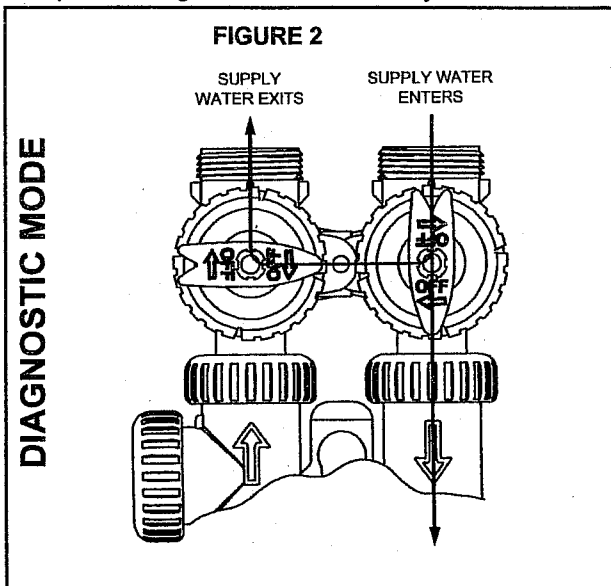

OPTIONAL MAINTENANCE WRENCH Part Number V3193

Although no tools are necessary to assemble the valve, the optional maintenance wrench (shown in various positions on the valve) may be purchased to aid in assembly or disassembly.

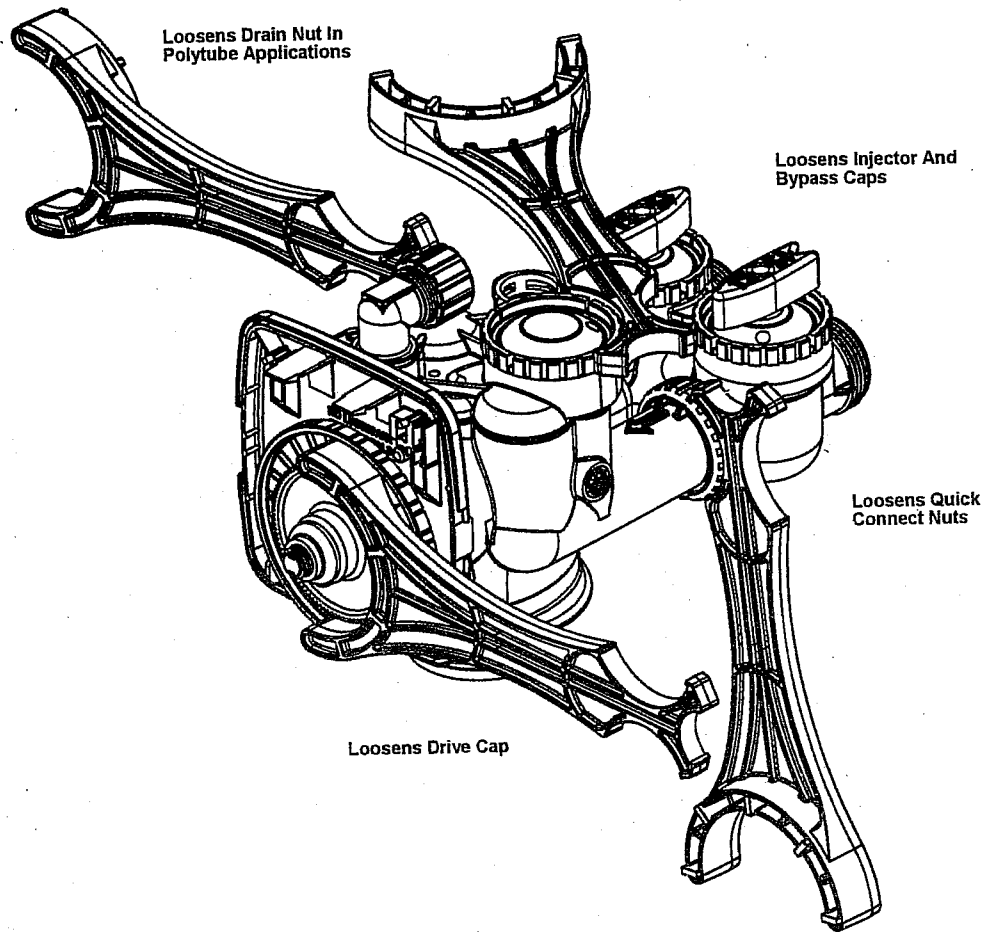

BYPASS VALVE:

The working parts of the bypass valve are the rotor assemblies that are contained under the bypass valve caps. Before working on the rotor, make sure the system is depressurized. Turn the red arrow shaped handles toward the center of the bypass valve and back to the arrow direction several times to ensure rotor is turning freely.

The nuts and caps are designed to be unscrewed or tightened by hand. If necessary a pliers can be used to unscrew the nut or cap. **DO NOT** use a pipe wrench to tighten or loosen nuts or caps. **DO NOT** place screwdriver in slots on caps and/or tap with a hammer. To access the rotor, unscrew the cap and lift the cap, rotor and handle out as one unit. Twisting the unit as you pull it out will help to remove it more easily. There are three o-rings: one under the rotor cap, one on the rotor stem and the rotor seal. Replace worn o-rings. Clean rotor. Reinstall rotor.

When reinstalling the red arrow handles be sure that:

1. O-rings on both rotors face to the right when being viewed from the front of the control valve when the handle pointers are lined up with the control valve body arrows; or
2. Arrows point toward each other in the bypass position.

Since the handles can be pulled off, they could be accidentally reinstalled 180° from their correct orientation. To install the red handles correctly, keep the handles pointed in the same direction as the arrows engraved on the control valve body while tightening the bypass valve caps.

After completing any valve maintenance, press and hold **NEXT** and **REGEN** buttons for 5 seconds or unplug power source jack (black wire) from the circuit board and plug back in. This resets the electronics and establishes the home position for softening. Reset the time of day.

SERVICE INSTRUCTIONS

DRIVE ASSEMBLY:

Remove the valve cover to access the drive assembly.

Disconnect the power source plug (black wire) from the PC board prior to disconnecting the motor plug from the PC board. The motor plug connects to the two-pin jack on the left-hand side of the PC board. The power source plug connects to the four-pin jack. The water meter plug (gray wire) connects to the three-pin jack on the far right-hand side of the PC board.

The PC board can be removed separately from the drive bracket but it is not recommended. Do not attempt to remove the display panel from the PC board. Handle the board by the edges. To remove the PC board from the drive bracket, unplug the power and motor plugs from the PC board. Lift the middle latch along the top of the drive bracket while pulling outward on the top of the PC board. The drive bracket has one plastic pin that fits into the hole in the lower edge of the PC board. Once the PC board is tilted about 45° from the drive bracket it can be lifted off the pin. To reinstall the PC board, position the lower edge of the PC board so that the hole in the PC board lines up with the plastic pin. Push the top of the PC board towards the valve. Align the upper hole on the left hand side of the PC board with the pin and push in until the PC board snaps under the middle latch, weave the power wire into the holders and reconnect the motor and power plugs.

The drive bracket must be removed to access the drive cap assembly and pistons or the drive gear cover. It is not necessary to remove the PC board from the drive bracket to remove the drive bracket. To remove the drive bracket start by removing the plug for the power source. Unweave the wire from the side holders. Two tabs on the top of the drive back plate hold the drive bracket in place. Simultaneously lift the two tabs and gently ease the top of the drive bracket toward your body. The lower edge of the drive bracket has two notches that rest on the drive back plate. Lift up and outward on the drive bracket to disengage the notches.

To reassemble seat the bottom of the drive bracket so the notches are engaged at the bottom of the drive back plate. Push the top of the drive bracket towards the two latches. The drive bracket may have to be lifted slightly to let the threaded piston rod pass through the hole in the drive bracket. Maintain a slight engaging force on the top of the drive bracket while deflecting the bracket slightly to the left by pressing on the side of the upper right corner. This helps the drive gears mesh with the drive cap assembly. The drive bracket is properly seated when it snaps under the latches on the drive back plate. If resistance is felt before latching, then the notches are not fully engaged, the piston rod is not in the hole, the power wire is jammed between the drive bracket and the drive plate, or the gear is not engaging the drive cap assembly.

To inspect drive gears, the drive gear cover needs to be removed. The drive gear is held in place on the drive bracket by three clips. The largest of the three clips is always oriented to the bottom of the drive bracket. Before trying to remove the drive gear cover, the drive bracket must be removed from the drive back plate. The drive gear cover can be removed from the drive bracket without removing the PC board. Simultaneously, push in and down on the large clip at the bottom and the clip on the left-hand side of the drive bracket behind the PC board. Keep your other fingers behind the drive gear cover so the drive gears do not drop on the ground.

Replace broken or damaged drive gears. Do not lubricate any of the gears. Avoid getting any foreign matter on the reflective coating because dirt or oils may interfere with pulse counting.

The drive gear cover only fits on one way, with the large clip oriented towards the bottom. If all three clips are outside of the gear shroud on the drive bracket the drive gear cover slips easily into place.

The drive bracket does not need to be removed from the drive plate if the motor needs to be removed. To remove the motor, disconnect the power and motor plugs from the jacks on the PC board. Move the spring clip loop to the right and hold. Rotate the motor at least a ¼ turn in either direction before gently pulling on the wire connectors to remove the motor. Pulling directly on the wire without rotating the motor may break the wires off the motor.

Replace the motor if necessary. Do not lubricate the motor or the gears. When reinstalling the motor gently turn the motor while inserting so that the gear on the motor meshes with the gears under the drive gear cover and the small plastic plug engages one of the slots on the motor housing. Reconnect the motor plug to the two pronged jack on the lower left-hand side of the PC board. If the motor will not easily engage with the drive gear when reinstalling, lift and slightly rotate motor before reinserting.

Replace the valve cover. After completing any valve maintenance, press and hold **NEXT** and **REGEN** buttons for 5 seconds or unplug power source jack (black wire) from the circuit board and plug back in. This resets the electronics and establishes the home position for softening. Reset the time of day.

DRIVE CAP ASSEMBLY, MAIN PISTON AND REGENERANT PISTON:

The drive assembly must be removed to access the drive cap assembly. The drive cap assembly must be removed to access the piston(s). The drive cap assembly is threaded into the control valve body and seals the o-ring. To remove the drive cap assembly use the optional maintenance wrench or insert a ¼" to ½" flat bladed screwdriver into one the slots around the top 2" of the drive cap assembly so it engages the notches molded into the drive back plate around the top 2" of the piston cavity (see figure 4). The notches are visible through the holes. Lever the screwdriver so the drive cap assembly turns counter-clockwise. Once loosened unscrew the drive cap assembly by hand and pull straight out.

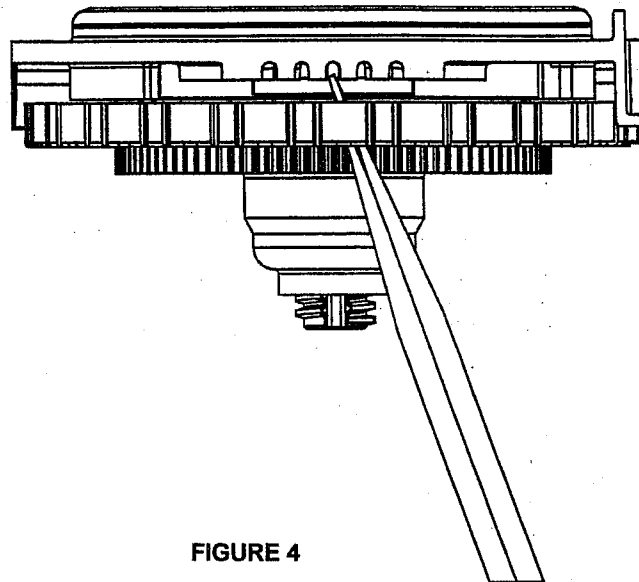

FIGURE 4

The drive cap assembly contains the drive cap, the main drive gear, drive cap spline, piston rod and various other parts that should not be disassembled in the field. The only replaceable part on the drive cap assembly is the o-ring. Attached to the drive cap assembly is the main piston and, a regenerant piston.

The regenerant piston (the small diameter one behind the main piston) is removed from the main piston by unsnapping it from its latch. Chemically clean in dilute sodium bisulfite or vinegar or replace the regenerant piston if needed. To remove the main piston fully extend the piston rod and then unsnap the main piston from its latch by pressing on the side with the number. Chemically clean in diluted sodium bisulfite or vinegar or replace the main piston.

Reattach the main piston to the drive cap assembly. Reattach the regenerant piston (if needed) to the main piston. Do not lubricate the piston rod, main piston or regenerant piston. Lubricant will adversely affect the red or clear lip seals. Reinsert the drive cap assembly and piston into the spacer stack assembly and hand tighten the drive cap assembly. Continue to tighten the drive cap assembly using the maintenance wrench or screwdriver as a ratchet until the black o-ring on the spacer stack assembly is no longer visible through the drain port. Excessive force can break the notches molded into the drive back plate. Make certain the main drive gear still turns freely. The exact position of the piston is not important as long as the main drive gear turns freely.

Reattach the drive assembly to the control valve and connect all plugs. After completing any valve maintenance, press and hold **NEXT** and **REGEN** buttons for 5 seconds or unplug power source jack (black wire) from the circuit board and plug back in. This resets the electronics and establishes the home position for softening. Reset the time of day.

SPACER STACK ASSEMBLY:

To access the spacer stack assembly remove the drive assembly, drive cap assembly and piston. The spacer stack assembly can be removed easily without tools by using your thumb and forefinger. Inspect the black o-rings and red or clear lip seals for wear or damage. Replace the entire stack if necessary. The spacer stack assembly has been 100% tested at the factory to insure proper orientation of one way seals. Do not disassemble stack.

The spacer stack assembly may be chemically cleaned (dilute sodium bisulfite or vinegar) or wipe with a soft cloth.

The spacer stack assembly can be pushed into the control valve body bore by hand. Since the spacer stack assembly can be compressed it is easier to use a blunt object (5/8" to 1 1/8" in diameter) to push the center of the assembly into the control valve body. The assembly is properly seated when at least four threads are exposed (approximately 5/8") Do not force the spacer stack assembly in. The control valve body bore interior can be lubricated with silicone to allow for easy insertion of the entire stack. Do not use silicone or any other type of lubricant on the red or clear lips seals or the piston.

Reattach the drive cap assembly and piston(s) and the drive assembly.

After completing any valve maintenance, press and hold **NEXT** and **REGEN** buttons for 5 seconds or unplug power source jack (black wire) from the circuit board and plug back in. This resets the electronics and establishes the home position for softening. Reset the time of day.

INJECTOR CAP, SCREEN, INJECTOR PLUG AND INJECTOR:

Unscrew the injector cap and lift off. Loosen cap with optional maintenance wrench or pliers if necessary. A screen is attached to the injector cap. Remove the screen and clean if fouled.

The plug and/or injector can be pried out with a small screwdriver. The plug can be wiped clean. If the plug leaks replace the entire plug. The injector consist of a throat and a nozzle. Chemically clean the injector with vinegar or dilute sodium bisulfite. The holes can be blown out with air. Both pieces have small diameter holes that control the flow rates of the water to insure that the proper concentration of the regenerant is used. Sharp objects, which can score the plastic, should not be used to clean the injector. Scoring the injector or increasing the diameter of the hole could change the operating parameters of the injector.

Two holes are labeled DN and UP. For down flow systems, the appropriate injector is located in the "DN" hole, a plug is in the "UP" hole. Push the plug and injector firmly in place, replace the screen and hand tighten the injector cap.

REFILL FLOW CONTROL ASSEMBLY OR REFILL PORT PLUG:

To clean or replace the refill flow control, pull out the elbow-locking clip and then pull straight up on the elbow. Replace the elbow locking clip in the slot so that it is not misplaced. Twist to remove the white flow control retainer. The flow control can be removed by prying upward through the side slots of the retainer with a small blade flat screwdriver.

Chemically clean the flow control or the white flow control retainer using dilute sodium bisulfite or vinegar. **DO NOT** use a wire brush. If necessary, replace the flow control, o-ring on the flow control retainer, or the o-ring on the elbow.

Reseat the flow control so the rounded end is visible in the flow control. Reseat the white flow control retainer by pushing the retainer into the elbow until the o-ring seats. Remove locking clip, push down on elbow to reseat and insert locking clip.

DO NOT use Vaseline, oils, or other unacceptable lubricants on o-rings. A silicone lubricant may be used on the o-ring on the elbow or white retainer.

WATER METER OR METER PLUG:

The water meter assembly is connected to the PC board by a wire. If the entire water meter assembly is to be replaced, remove the control valve cover and remove the power source and water meter plugs from the PC board. Unlatch the drive assembly and lean it forward. Unthread the water meter wire from the side of the drive assembly and through the drive plate. To reinstall, rethread the water meter wire through the drive back plate and the side if the drive assembly. Reattach the drive assembly and the water meter and power plugs.

The water meter wire does not need to be removed from the PC board if the water meter is only being inspected and cleaned. To remove the water meter assembly, unscrew the meter cap on the left side of the control valve. Pliers may be used to unscrew the nut if necessary.

With the nut removed, a slot at the top of the water meter is visible. Twist a flat blade screwdriver in the slot between the control valve body and the meter. When the meter is part way out it is easy to remove the water meter from the housing. Once the water meter is removed from the control valve body, use your fingers to gently pull forward on the turbine to remove it from the shaft.

Do not use a wire brush to clean. Wipe with a clean cloth or chemically clean in dilute sodium bisulfite or vinegar. The turbine can be immersed in the chemical. Do not immerse electronics. If the turbine is scored or damaged or the bearings on the turbine are worn replace the turbine.

Do not lubricate the turbine shaft. The turbine shaft bearings are pre-lubricated. Do not use Vaseline, oils or other unacceptable lubricants on the o-ring. A silicone may be used on the black o-ring.

Snap the turbine on the shaft and reinsert the water meter into the side slot. Hand tighten the nut. Do not use a pipe wrench to tighten nut.

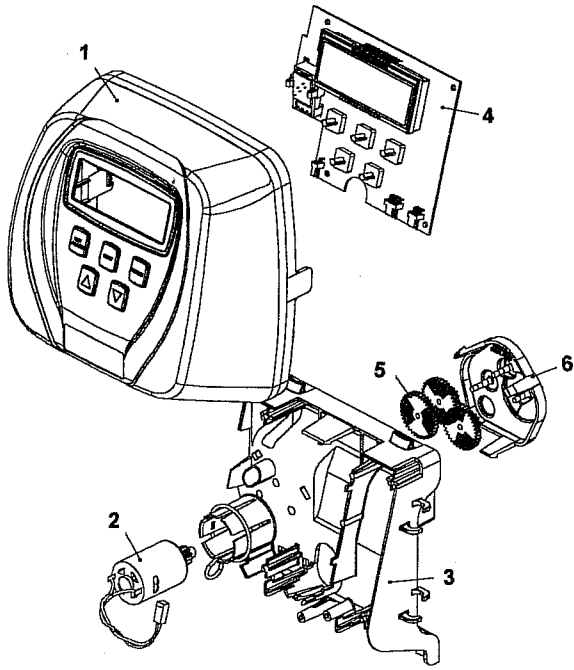

FRONT COVER AND DRIVE ASSEMBLY

Item No.	Quantity	Part No.	Description
1	1	V3175CC	Front Cover Assembly
2	1	V3107	Motor
3	1	V3106	Drive Bracket & Spring Clip
4	1	V3108CC	PC Board
5	3	V3110	Drive Gear 12 x 36
6	1	V3109	Drive Gear Cover
2 thru 6		V3002CC	Drive Assembly - (parts 2-6)
Not Shown	1	V3186	Transformer 110V-12V

DRIVE CAP ASSEMBLY, DOWNFLOW PISTON, REGENERANT PISTON AND SPACER STACK ASSEMBLY

Item No.	Quantity	Part No.	Description
1	1	V3005	Spacer Stack Assembly
2	1	V3004	Drive Cap Assembly
3	1	V3135	O-Ring 228
4	1	V3011	Piston Assembly
5	1	V3174	Regenerant Piston
6	1	V3180	O-Ring 337

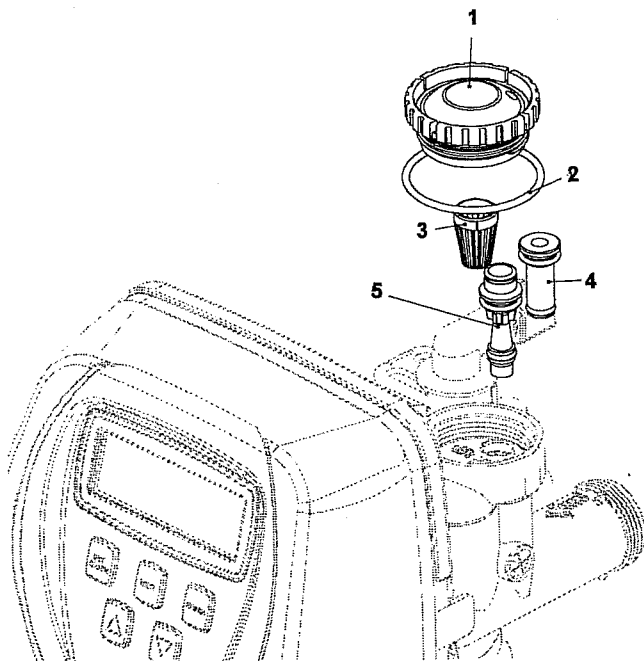
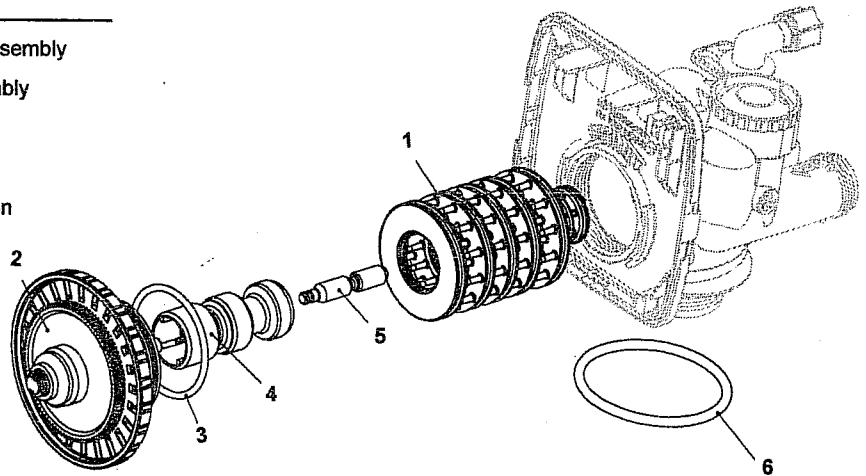

INJECTOR, INJECTOR CAP, SCREEN AND O-RING

Item No.	Quantity	Part No.	Description
1	1	V3176	Injector Cap
2	1	V3152	O-Ring 135
3	1	V3177	Injector Screen
4	1	V3010-1Z	Injector Assy Z Plug
5	1	V3010-1C	Injector Assy C Violet - 8" Tank
5	1	V3010-1E	Injector Assy E White - 10" Tank
5	1	V3010-1F	Injector Assy F Blue - 12" Tank
Not Shown	*	V3170	O-Ring 011
Not Shown	*	V3171	O-Ring 013

* Injector plug and injector each contain one 011 and one 013 O-Ring

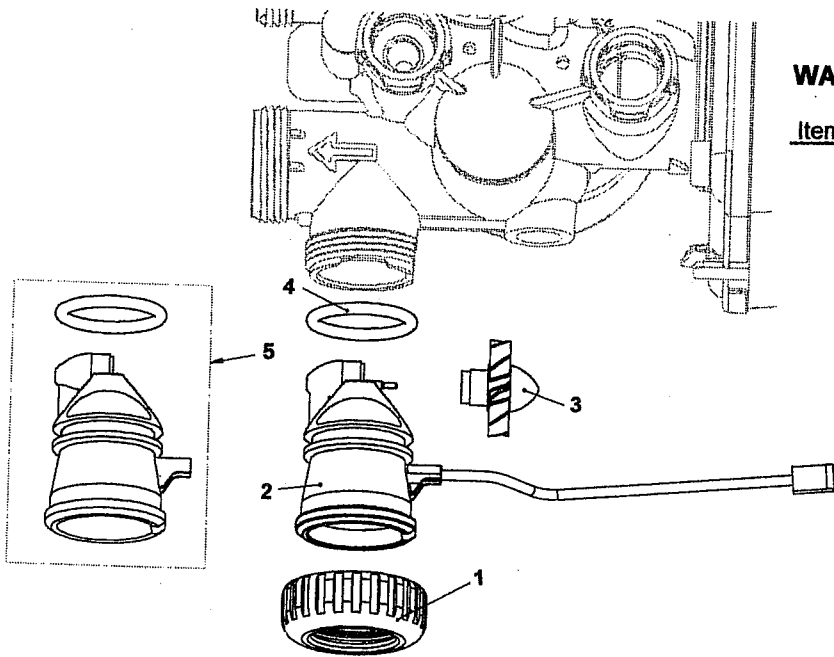

WATER METER AND METER PLUG

Item No.	Quantity	Part No.	Description
1	1	V3151	Nut 1" QC
2	1	V3003*	Meter Assy
3	1	V3118-01	Turbine Assy
4	1	V3105	O-Ring 215
5	1	V3003-01	Meter Plug Assy

*Part No. V3003 includes Items 2, 3 and 4

DRAIN LINE - 3/4"

Item No.	Quantity	Part No.	Description
1	1	H4615	Elbow Locking Clip
2	1	V3194	Polytube Insert 5/8
3	1	V3192	Nut for 3/4 Drain Elbow
4	1	V3158	3/4 Drain Elbow
5	1	V3163	O-Ring 019
6	1	V3159	DLFC Retainer
7	1	V3162-017	DLFC 1.7 for 8" Tank
7	1	V3162-022	DLFC 2.2 For 10" Tank
7	1	V3162-027	DLFC 2.7 for 10" Tank
7	1	V3162-032	DLFC 3.2 for 12" Tank

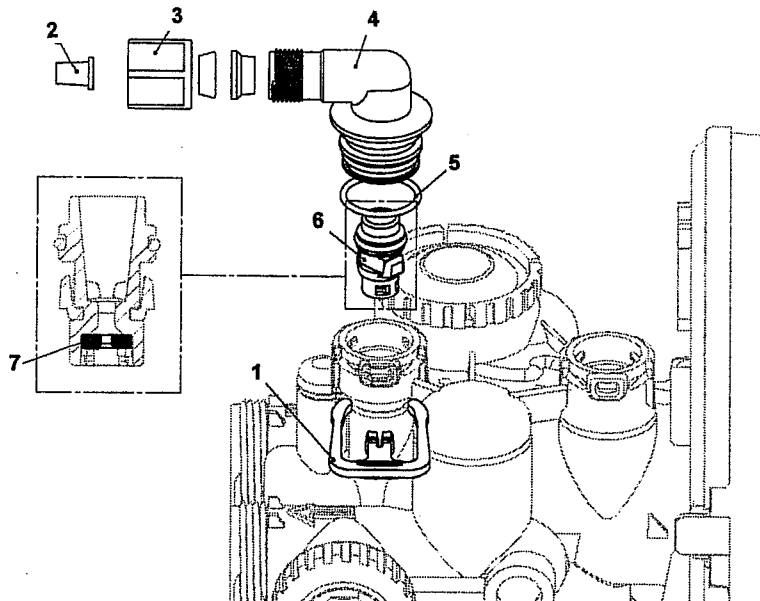
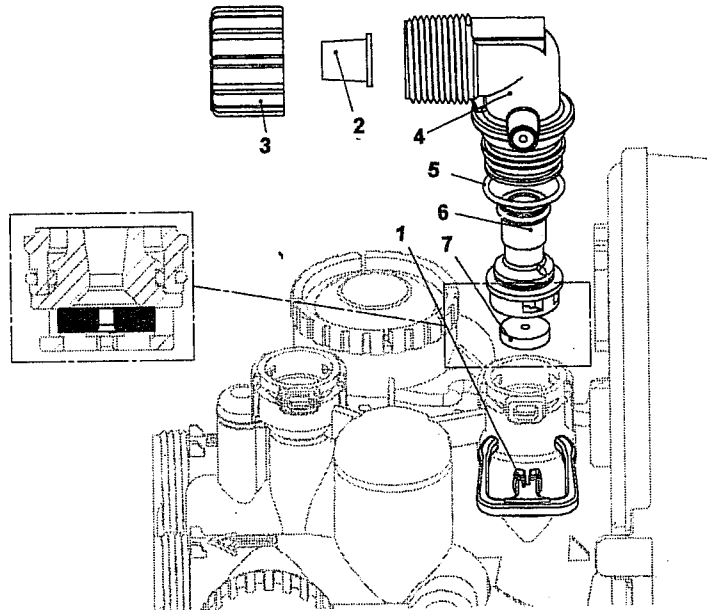

BRINE REFILL

Item No.	Quantity	Part No.	Description
1	1	H4615	Elbow Locking Clip
2	1	H4614	Polytube Insert 3/8"
3	1	H4612	Nut 3/8"
4	1	H4613	Elbow Cap 3/8"
5	1	V3163	O-Ring 019
6	1	V3165	RFC Retainer Assy
7	1	V3182	RFC

*Part No. V3165 Includes Items 6 and 7

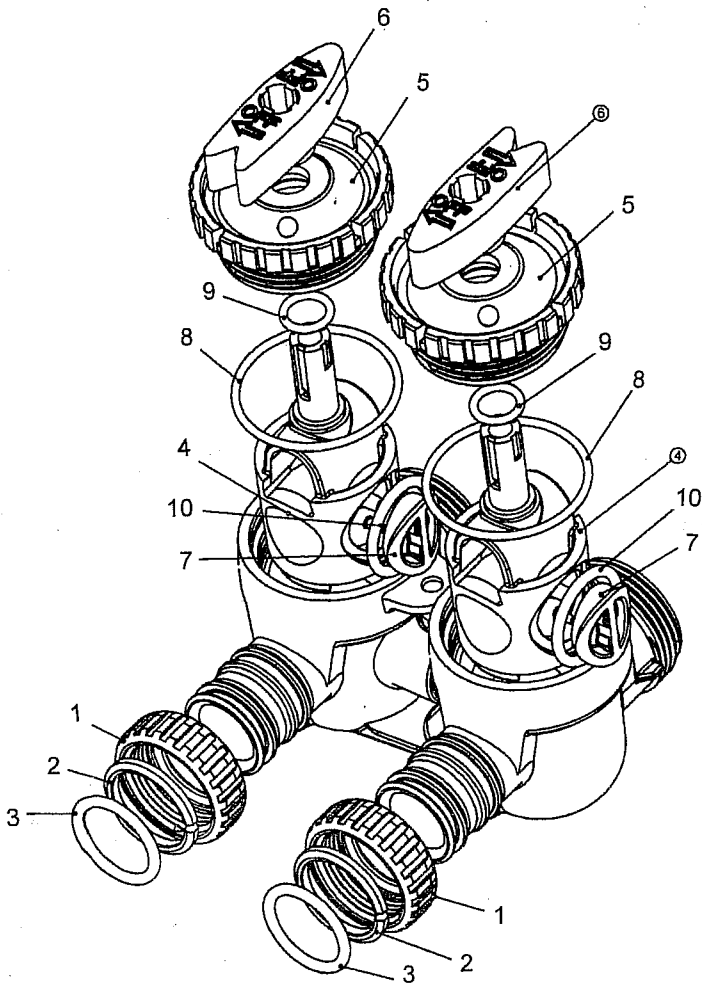

BP2000 Bypass Valve

Item No.	Quantity	Part No.	Description
1	2	V3151	Nut 1" Quick Connect
2	2	V3150	Split Ring
3	2	V3105	O-Ring 215
4	2	V3145	Bypass 1" Rotor
5	2	V3146	Bypass Cap
6	2	V3147	Bypass Handle
7	2	V3148	Bypass Rotor Seal Retainer
8	2	V3152	O-Ring 135
9	2	V3155	O-Ring 112
10	2	V3156	O-Ring 214

V3007 1" PVC Male NPT Elbow Assembly Standard

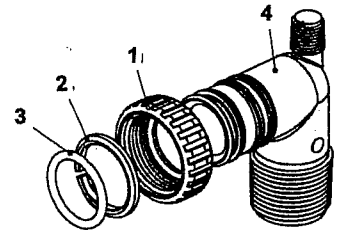

Item No.	Quantity	Part No.	Description
1	2	V3151	Nut 1" Quick Connect
2	2	V3150	Split Ring
3	2	V3105	O-Ring 215
4	2	V3149	1" PVC Male NPT Elbow

V3007-02 1" Brass Sweat Assembly Optional

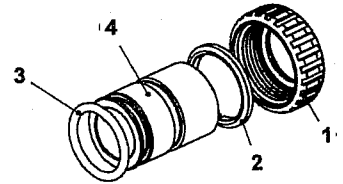

Item No.	Quantity	Part No.	Description
1	2	V3151	Nut 1" Quick Connect
2	2	V3150	Split Ring
3	2	V3105	O-Ring 215
4	2	V3188	Fitting—1" Brass Sweat

V3007-03 3/4" Brass Sweat Assembly Optional

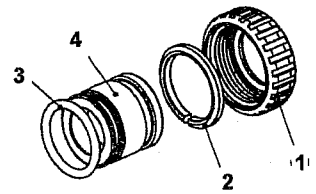

Item No.	Quantity	Part No.	Description
1	2	V3151	Nut 1" Quick Connect
2	2	V3150	Split Ring
3	2	V3105	O-Ring 215
4	2	V3188-01	Fitting—3/4" Brass Sweat

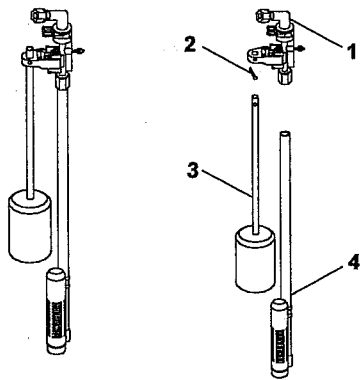

4740 Brine Valve Assembly

Item No.	Quantity	Part No.	Description
1	1	H4600	3/8" Safety Brine Valve
2	2	10151	Pin
3	1	H4640-32	Float Assembly
4	1	H4500-30.50	Air Check Assembly

V3191-01 Vertical Adapter Assembly Optional

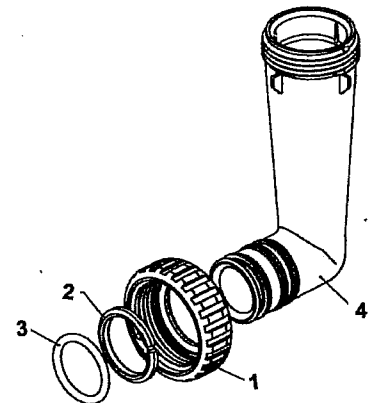

Item No.	Quantity	Part No.	Description
1	2	V3151	Nut 1" Quick Connect
2	2	V3150	Split Ring
3	2	V3105	O-Ring 215
4	2	V3191	Vertical Adapter

TROUBLESHOOTING PROCEDURES

<u>PROBLEM</u>	<u>POSSIBLE CAUSE</u>	<u>SOLUTION</u>
1. Timer does not display time of day.	<ul style="list-style-type: none"> a. Transformer unplugged b. No electric power at outlet c. Defective transformer d. Defective PC board 	<ul style="list-style-type: none"> a. Connect power b. Repair outlet or use working outlet c. Replace transformer d. Replace PC board
2. Timer does not display correct time of day.	<ul style="list-style-type: none"> a. Switched outlet b. Power outage c. Defective PC board 	<ul style="list-style-type: none"> a. Use uninterrupted outlet b. Reset time of day c. Replace PC board
3. No Softening/filtering display when water is flowing.	<ul style="list-style-type: none"> a. Bypass valve in bypass position. b. Meter connection disconnected. c. Restricted/stalled meter turbine. d. Defective meter. e. Defective PC board. 	<ul style="list-style-type: none"> a. Put bypass valve in service position b. Connect meter to PC board c. Remove meter and check for rotation or foreign material d. Replace meter e. Replace PC board
4. Control valve regenerates at wrong time of day.	<ul style="list-style-type: none"> a. Power outages b. Time of day not set correctly c. Time of regeneration incorrect d. Control valve set at "on O" (immediate regeneration) e. Control valve set at NORMAL + O 	<ul style="list-style-type: none"> a. Reset control valve to correct time of day b. Reset to correct time of day c. Reset regeneration time d. Check control valve set-up procedure regeneration time option e. Check control valve set-up procedure regeneration time option
<p>5. ERROR followed by Code number:</p> <p>Error Code 1001– Unable to recognize start of regeneration.</p> <p>Error Code 1002– Unexpected stall.</p> <p>Error Code 1003 – Motor ran to long, timed out trying to reach next cycle position.</p> <p>Error Code 1004 – Motor ran to long, timed out trying to reach home position.</p> <p>If other Error Codes display contact the factory.</p>	<ul style="list-style-type: none"> a. Control valve has just been serviced b. Foreign matter is lodged in control valve c. High drive forces on piston d. Control valve piston not in home position e. Motor not inserted fully to engage pinion, motor wires broken or disconnected, motor failure f. Drive gear label dirty or damaged, missing or broken gear g. Drive bracket incorrectly aligned to back plate h. PC board is damaged or defective i. PC board incorrectly aligned to drive bracket 	<ul style="list-style-type: none"> a. Press NEXT and REGEN for 3 seconds or unplug power source jack (black wire) and plug back in to reset control valve. b. Check piston and spacer stack assembly for foreign matter. c. Replace piston (s) and spacer stack assembly. d. Press NEXT and REGEN for 3 seconds or unplug power source jack (black wire) and plug back in to reset control valve. e. Check motor and wiring. Replace motor if necessary. f. Replace or clean drive gear. g. Reset drive bracket properly. h. Replace PC board. i. Ensure PC board is correctly snapped onto drive bracket.
6. Control valve stalled in regeneration.	<ul style="list-style-type: none"> a. Motor not operating b. No electric power at outlet c. Defective transformer d. Defective PC board e. Broken drive gear or drive cap assembly f. Broken piston retainer g. Broken main or regenerant piston 	<ul style="list-style-type: none"> a. Replace motor b. Repair outlet or use working outlet c. Replace transformer d. Replace PC board e. Replace drive gear or drive cap assembly f. Replace drive cap assembly g. Replace main or regenerant piston
7. Control valve does not regenerate automatically when REGEN button is depressed and held.	<ul style="list-style-type: none"> a. Transformer unplugged b. No electric power at outlet c. Broken drive gear or drive cap assembly d. Defective PC board 	<ul style="list-style-type: none"> a. Connect transformer b. Repair outlet or use working outlet c. Replace drive gear or drive cap assembly d. Replace PC board
8. Control valve does not regenerate automatically but does when REGEN button is depressed.	<ul style="list-style-type: none"> a. Bypass valve in bypass position b. Meter connection disconnected c. Restricted/stalled meter turbine d. Defective meter e. Defective PC board f. Set-up error 	<ul style="list-style-type: none"> a. Put control valve in service piston b. Connect meter to PC board c. Remove meter and check for rotation or foreign matter d. Replace meter e. Replace PC board f. Check control valve set-up procedure
9. Time of day flashes on and off.	<ul style="list-style-type: none"> a. Power has been out more than two hours, the transformer was unplugged and then plugged back into the wall outlet, the transformer plug was unplugged and then plugged back into the board or the NEXT and REGEN buttons were pressed to reset the valve. 	<ul style="list-style-type: none"> a. Reset the time of day

LANCASTER WATER TREATMENT A DIVISION OF C-B TOOL CO.

1340 Manheim Pike ♦ Lancaster, PA 17601-3196 ♦ Tel 717-397-3521 ♦ Fax 717-392-0266

www.lancasterpump.com ♦ E-mail: info@lancasterpump.com