



OIL FIRED UPFLOW FURNACE SPECIFICATIONS

MODEL NO.	OH6FA072D48B			OH6FA072D48R		
	High Fire	Med Fire	Low Fire	High Fire	Med Fire	Low Fire
HEATING CAPACITY						
HEAT INPUT RATE (BTUH)	106,250	85,000	70,000	106,250	85,000	70,000
OUTPUT BTUH ¹	90,000	73,000	60,000	91,000	74,000	61,500
SEASONAL EFFICIENCY ²	83.3%	83.3%	84.0%	85.2%	86.1%	85.4%
LARGEST REC A/C ³	4 Tons			4 Tons		
NOMINAL TEMP RISE	60°	60°	60°	60°	60°	60°
HEAT EXCHANGE AREA						
CASING HEIGHT (IN.):	45"			45"		
CASING WIDTH (IN.):	20"			20"		
CASING DEPTH (IN.):	30"			30"		
NOMINAL FLUE OUTLET DIA.	5"			5"		
APPROX SHIPPING WEIGHT	250			250		
APPROVAL AGENCY	U.L.			U.L.		
QTY AND SIZE OF PERMANENT FILTERS	(1) 24 3/4" X 15 3/4"			(1) 24 3/4" X 15 3/4"		
ELECTRICAL REQUIREMENTS	120/60/1			120/60/1		
MAX FUSE SIZE PSC/ECM	15 / 15			15 / 15		
TOTAL CURRENT (AMPS) PSC/ECM	8.7 / 12.1			8.7 / 12.1		
HEIGHT FROM FLOOR TO CENTER OF FLUE	40 3/4"			40 3/4"		
SUPPLY AIR OUTLET SIZE (W-IN. X D-IN.)	18" X 19"			18" X 19"		
RETURN AIR DUCTWORK CONNECTION FLANGE SIZE ON FILTER RACK (D-IN. X H-IN.)	24 1/2" X 15"			24 1/2" X 15"		
RETURN AIR INLET OPENING SIZE IN SIDE CASING (TO BE CUT-OUT BY DEALER) (D-IN. X H-IN.)	23" X 14"			23" X 14"		
	ACCESSORY ITEMS					
PROGRAMMABLE T-STAT	350866			350866		
COMBUSTION AIR INTAKE HOOD KIT	AOPS7402			AOPS7402		
FIELD VENT TERMINATION KIT	AOPS8393			AOPS8393		
SIDEWALL VENT ACCESSORIES KIT	AOPS8394			AOPS8395		
COMBUSTION AIR KIT FOR BECKETT	AOPS8397					

- SEE NEXT PAGE FOR MORE DATA -

¹ OUTPUT BTUH BASED ON ANNUAL FUEL UTILIZATION EFFICIENCY RATED BY MANUFACTURER.

² SEASONAL EFFICIENCY (ALSO CALLED AFUE - ANNUAL FUEL UTILIZATION EFFICIENCY) RATINGS ARE BASED ON TESTS FOLLOWING U.S. DEPARTMENT OF ENERGY TEST PROCEDURES.

³ TO PERMIT LARGEST RECOMMENDED AIR CONDITIONING (AT .5 STATIC PRESSURE), SELECTION OF THE HIGHEST MOTOR SPEED IS REQUIRED.

Model Number Digit	1	2	3	4	5	6	7	8	9	10	11	12
	Fuel	Configuration	Heat Exchanger Identifier	Flue	Design Change	Capacity	Capacity	Capacity	Blower Type	Clg Airflow Cap.	Clg Airflow Cap.	Burner
Oil Furnace Model Nomenclature Example Model Numbers	O	H	6	F	A	0	7	2	D	4	8	B
	O	H	6	F	A	0	7	2	D	V	4	R
O = Oil	O											
H = Highboy		H										
6 = Heat Exchanger Size Identifier			6									
F = Front				F								
Design Change					A							
Heating Capacity MBTUH (000's) with factory installed nozzle						0	7	2				
D = Direct Drive									D			
Clg. Airflow: Example = 48MBTUH = 4 tons @ 400cfm/ton										4	8	
Clg. Airflow Variable Speed (ECM) V4= 4tons										V	4	
B = Beckett, R = Riello												B

- SEE NEXT PAGE FOR MORE DATA -

OIL FIRED UPFLOW FURNACE SPECIFICATIONS

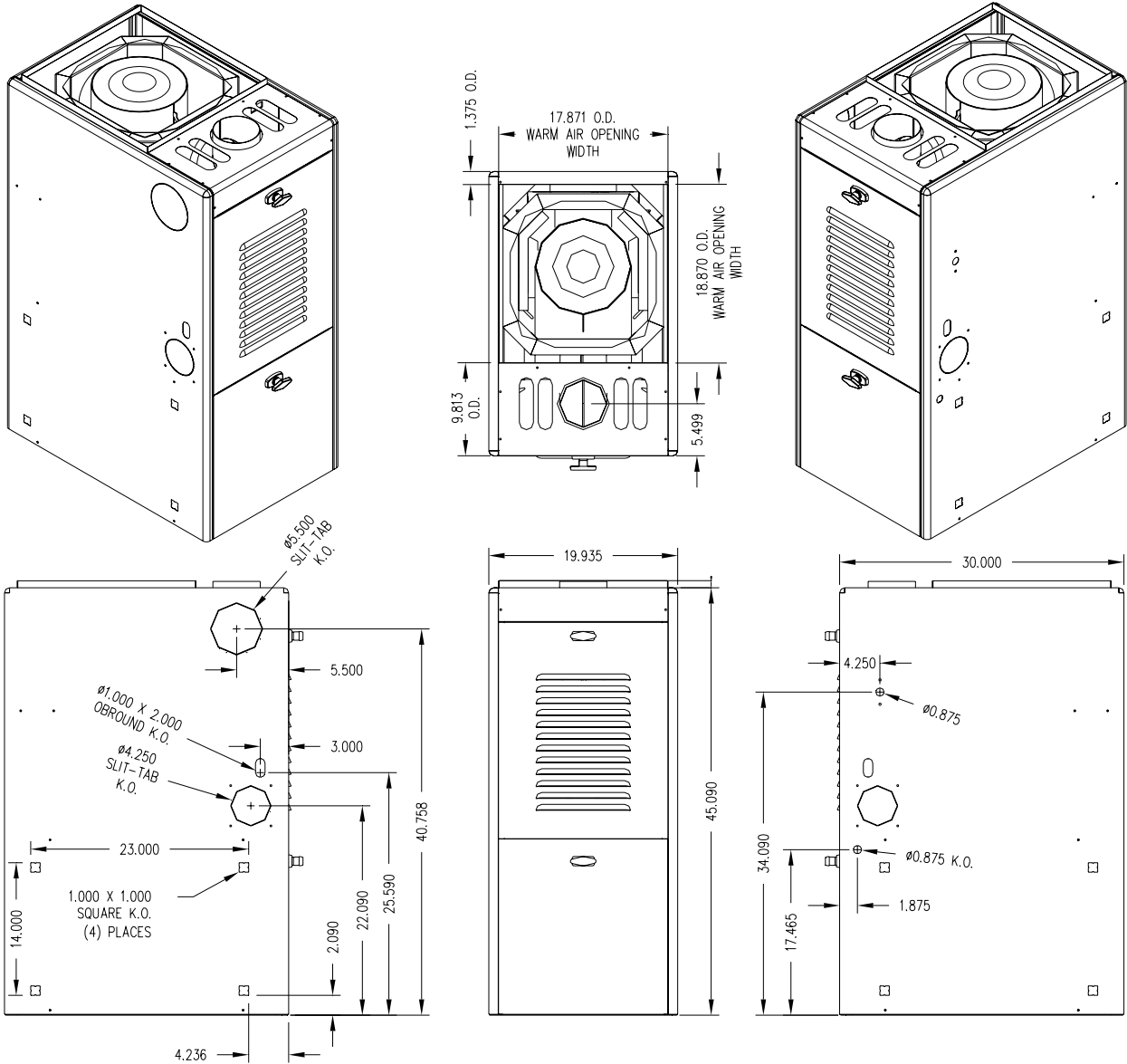

FILTER RACK SPECIFICATIONS

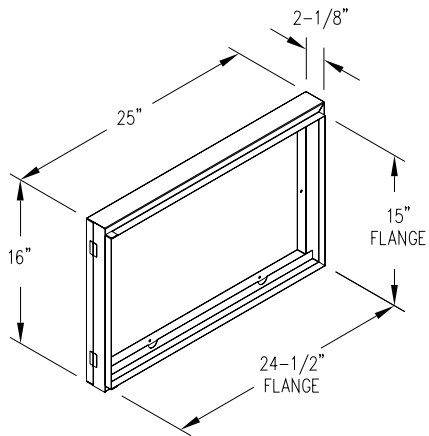

- SEE NEXT PAGE FOR MORE DATA -

OIL FIRED UPFLOW FURNACE SPECIFICATIONS

BLOWER DATA:	OH6FA072D48	OH6FA072DV4
BLOWER MODEL⁴	DD 100-9R	DD 100-9R
MOTOR H.P.	½ HP	¾ HP Variable Speed
MOTOR TYPE & NUMBER OF SPEEDS	PSC - 4	ECM -
HIGH SPEED AIRFLOW (SCFM) @ 0.5 IN. W.G. EXTERNAL STATIC PRESSURE:	1569	1600
Diameter x Width	10 x 9	10 x 9

BURNER DATA	RIELLO "BF3" WITH CERA-FELT SLEEVE		
AIR TUBE LENGTH (IN.)	4 ½"		
BURNER HEAD TYPE:	Fixed		
FUEL TYPE:	#2		
NOZZLE RATING (GPH):	70-80° A	60-80° A	50-80° A
SPRAY ANGLE (DEG.):	80°	80°	80°
SPRAY PATTERN:	HOLLOW	HOLLOW	HOLLOW
OIL PUMP PRESSURE (PSIG):	140 PSI		
COMBUSTION CHAMBER TYPE:	REFRACTORY (HARD CERAMIC)		

BURNER DATA	BECKETT "AFG" S - PLATE 3384 (3 3/8") 31517 CERAMIC		
AIR TUBE LENGTH (IN.)	4 ½"		
BURNER HEAD TYPE:	F-3		
FUEL TYPE:	#2		
NOZZLE RATING (GPH):	75-80° A	60-80° A	50-80° A
SPRAY ANGLE (DEG.):	80°	80°	80°
SPRAY PATTERN:	HOLLOW	HOLLOW	HOLLOW
OIL PUMP PRESSURE (PSIG):	120 PSI		
COMBUSTION CHAMBER TYPE:	REFRACTORY (HARD CERAMIC)		

CLEARANCES	
	MINIMUM CLEARANCES TO COMUSTIBLE MATERIALS:
SIDES	0"
FRONT (SERVICE ACCESS)	(Clearance to Combustibles) 6" / 24" (Service)
REAR	0"
FLUE	7"
TOP PLENUM	1"
SIDES PLENUM	1"

⁴ DD = DIRECT DRIVE

- SEE NEXT PAGE FOR MORE DATA -

OIL FIRED UPFLOW FURNACE SPECIFICATIONS

OH6FA072D48

ALTERATIONS REQ'D FOR A/C @ DESIGN EXTERNAL STATIC PRESSURE				
COOLING UNIT	HTG Speed by Input			Recommended CLG Speed
	Low Fire	Mid Fire	High Fire	
24,000	Low	ML	MH	Low
30,000	Low	ML	MH	Med Low
36,000	Low	ML	MH	Med High
42,000	Low	ML	MH	Med High
48,000	Low	ML	MH	High

Speed Tap\ Static Pressure	Furnace Airflow (CFM) vs. External Static pressure (in. WC.)						
	0.1	0.2	0.3	0.4	0.5	0.6	0.7
Low	930	915	912	910	822	774	730
ML	1155	1152	1130	1126	1085	1042	920
MH	1442	1432	1418	1382	1334	1293	1230
High	1802	1762	1705	1635	1569	1493	1428

Speed Tap\ Static Pressure	Furnace Motor Current Draw (Amps) vs. External Static pressure (in. WC.)						
	0.1	0.2	0.3	0.4	0.5	0.6	0.7
Low	3.28	3.1	3.02	2.91	2.64	2.49	2.36
ML	4.18	4.02	3.91	3.74	3.59	3.34	2.95
MH	5.44	5.17	4.95	4.72	4.43	4.21	3.95
High	6.61	6.36	6.04	5.73	5.46	5.17	4.9

Speed Tap\ Static Pressure	High Fire Temperature Rise vs. External Static pressure (in. WC.)						
	0.1	0.2	0.3	0.4	0.5	0.6	0.7
Low	90	91	91	92	101	108	114
ML	72	72	74	74	77	80	91
MH	58	58	59	60	62	64	68
High	46	47	49	51	53	56	58

Speed Tap\ Static Pressure	Mid Fire Temperature Rise vs. External Static pressure (in. WC.)						
	0.1	0.2	0.3	0.4	0.5	0.6	0.7
Low	72	73	73	73	81	86	91
ML	58	58	59	59	61	64	72
MH	46	47	47	48	50	52	54
High	37	38	39	41	42	45	47

Speed Tap\ Static Pressure	Low Fire Temperature Rise vs. External Static pressure (in. WC.)						
	0.1	0.2	0.3	0.4	0.5	0.6	0.7
Low	60	61	61	61	68	72	76
ML	48	48	49	49	51	53	60
MH	39	39	39	40	42	43	45
High	31	32	33	34	35	37	39

- SEE NEXT PAGE FOR MORE DATA -

OIL FIRED UPFLOW FURNACE SPECIFICATIONS

OH6FA072DV4

Heating Speed Set-ups

			Low Fire	Med Fire	High Fire
		BTUH	60,000	72,000	90,000
Fan Control SW 1 Switch Settings	Heating CFM		Aprox. Rise (F°)	Aprox. Rise (F°)	Aprox. Rise (F°)
3-OFF 2-OFF 1-OFF	740		75°	80°	
3-OFF 2-OFF 1-ON	812		68°	82°	
3-OFF 2-ON 1-OFF	883		63°	76°	84°
Factory SW1 Switch Settings					
3-OFF 2-ON 1-ON	968		57°	69°	86°
3-ON 2-OFF 1-OFF	1054			63°	79°
3-ON 2-OFF 1-ON	1153			58°	72°
3-ON 2-ON 1-OFF	1267				66°
3-ON 2-ON 1-ON	1424				58°

= Recommended Heating Speed Setting

- SEE NEXT PAGE FOR MORE DATA -

OIL FIRED UPFLOW FURNACE SPECIFICATIONS

OH6FA072DV4

Cooling Speed Set-ups

		Air Flow		
Fan Control SW 1 Switch Settings	Clg. Tonnage	Cool	Continuous	
6-OFF 5-OFF 4-OFF	2	799	500	
6-OFF 5-OFF 4-ON	2.5	1017	508	
6-OFF 5-ON 4-OFF	3	1210	605	
6-OFF 5-ON 4-ON	3.5	1404	702	
Factory SW1 Switch Settings 6-ON 5-OFF 4-OFF	4	1622	799	

- SEE NEXT PAGE FOR MORE DATA -

OIL FIRED UPFLOW FURNACE SPECIFICATIONS A/C EVAPORATOR COIL APPLICATION

CONDENSER FURNACE	13 SEER				
	AC13241B1	AC13301B1	AC13361B1	AC13421B1	AC13481B1 AC13483B1
	UPFLOW (CASED) COIL				
OH6FA072D48	12C2436AG19	12C2436AG19	12C4848HH21 ⁵	12C3642AG19	12C4848HH21 ⁶
OH6FA072DV4	12C2436AG19	12C2436AG19	12C3642AG19 ⁷	12C3642AG19	12C4848HH21 ⁸
CONDENSER FURNACE	14 SEER				
	AC14241C1	AC14301C1	AC14361C1	AC14421C1	AC14481C1 AC14483C1
	UPFLOW (CASED) COIL				
OH6FA072D48	12C2436AG19	12C2436AG19	12C4848HH21 ⁹	12C3642AG19	
OH6FA072DV4	12C2436AG19	12C2436AG19	12C3642AG19	12C3642AG19	12C4848HH21 ¹⁰

⁶ -NEEDS PLENUM ADAPTER AOPS7695

⁷ -NEEDS PLENUM ADAPTER AOPS7694