



INSTALLATION INSTRUCTIONS

FOA(N,P) 45 THRU 125

SEPARATED COMBUSTION UNIT HEATERS

PRODUCT LITERATURE
Atlanta, GA

Table Of Contents

Unit Dimensions.....	1, 2	Leak Check.....	13
Shipping.....	3	Start-up Operation.....	14
Requirements.....	3	Heating Sequence of Operation.....	16
Unit Heater Installation.....	4	Ignition Control LED.....	16
Combustion & Ventilation Air.....	4	Adjustments.....	17
Venting.....	5	Service.....	19
Electrical Connections.....	12	Wiring Diagram.....	20
Gas Connection.....	13	Warranty.....	21

**RETAIN THESE INSTRUCTIONS
FOR FUTURE REFERENCE**



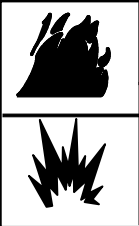



WARNING

If the information in this manual is not followed exactly, a fire or explosion may result causing property damage, personal injury or loss of life.



WHAT TO DO IF YOU SMELL GAS:

- Do not try to light any appliance.
- Extinguish any open flame.
- Do not touch any electrical switch; do not use any phone in your building.
- Immediately call your gas supplier from a neighbor's phone. Follow the gas supplier's instructions.
- If you cannot reach your gas supplier; call the fire department.

Do not store or use gasoline or other flammable vapors and liquids in the vicinity of this or any other appliance.

Installation and service must be performed by a qualified installer, service agency or the gas supplier.

START-UP AND PERFORMANCE CHECK LIST

Job Name: _____	Job No.: _____	Date: _____
Job Location: _____	City: _____	State/Province: _____
Installer: _____	City: _____	State/Province: _____
Unit Model No.: _____	Serial No.: _____	Service Technician: _____
Electrical Connections Tight? _____	Flue Connections Tight? _____	
Supply Voltage _____	Unit Operation Checked? _____	
Gas Piping Connections Tight & Leak Tested? _____	THERMOSTAT _____	
Motor Amps _____	Calibrated? _____	
Unit BTU Input _____	Heat Anticipator Properly Set? _____	
Line Pressure _____	Level? _____	
Manifold Pressure _____ in w. c.		

45, 60, and 75 UNIT DIMENSIONS

DIMENSION	45	60/75
A	12 (305)	17 (432)
B	5-1/2 (140)	6-1/2 (165)
C	7-3/4 (197)	10-1/4 (260)
D	1-3/4 (44)	3-1/4 (83)
E	5-1/4 (133)	5-3/4 (146)

MOUNTING SLOTS (Typical)
5/16 x 3"es (8 x 76 mm)

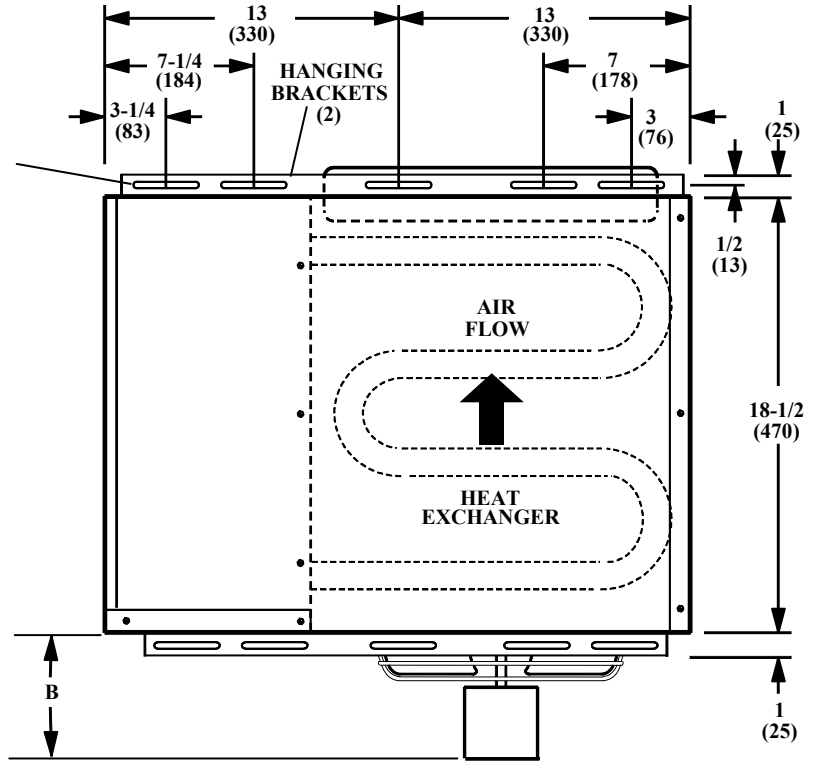

TOP VIEW

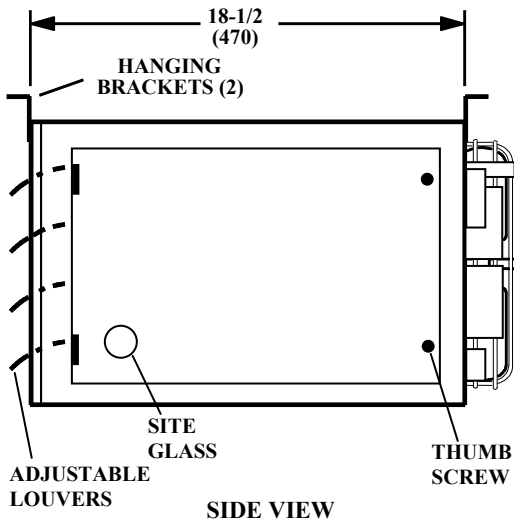

SIDE VIEW

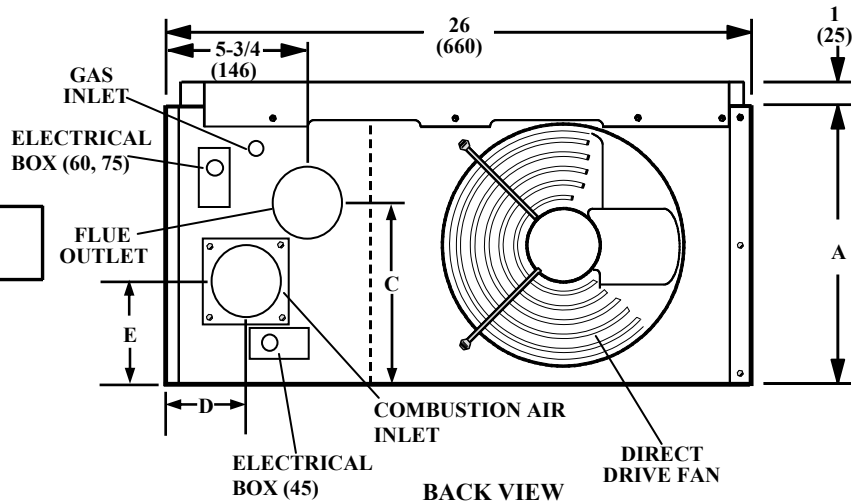

BACK VIEW

100 and 125 UNIT DIMENSIONS

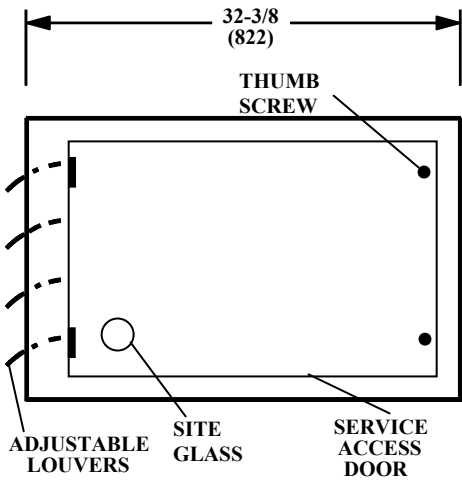
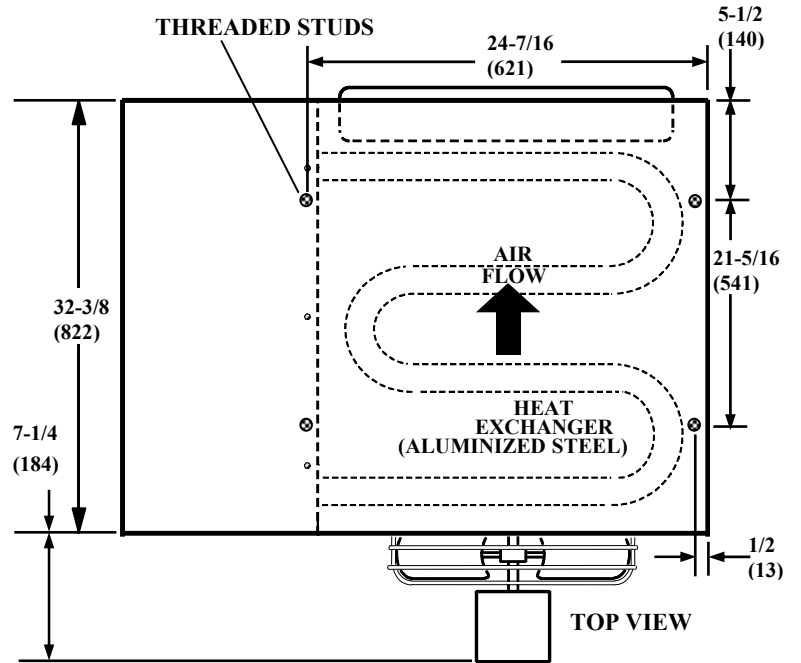

SIDE VIEW

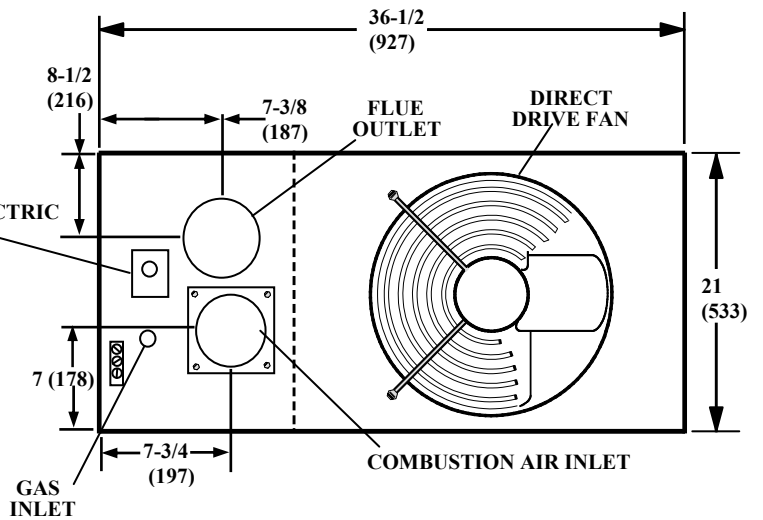

BACK VIEW

**TABLE 1
UNIT CLEARANCES**

Top		Sides		Access Panel		Bottom		Rear		Single Wall Vent*	
in	mm	in	mm	in	mm	in	mm	in	mm	in	mm
1	25	1	25	18	457	0	0	18	457	6	152

*Except for listed clearance thimbles

Shipping

The heater is completely assembled. Two mounting brackets are included with the 45, 60, and 75 size units. Check the unit for shipping damage. The receiving party should contact the last carrier immediately if any shipping damage is found.

Requirements – CSA in the USA

Installation of gas unit heaters must conform with local building codes or, in the absence of local codes, with the current National Fuel Gas Code ANSI Z223.1.

Installation in aircraft ft hangers must be in accordance with the current Standard for Aircraft ft Hangers ANSI/NFPA No. 409.

Installation in parking structures must be in accordance with the current Standard for Parking Structures ANSI/NFPA No. 88A.

Installation in repair garages must be in accordance with the current Standard for Repair Garages ANSI/NFPA No. 88B.

These units are approved for residential applications. Residential applications are defined as installations for heating non-living spaces that are attached to, adjacent to or part of a structure that contains space for family living quarters. For installation in a residential garage these units must be installed so that burners and ignition source are located no less than 18" (457 mm) above floor. Heater must be located or protected to avoid physical damage by vehicles. Refer to the National Fuel Gas Code, ANSI Z223.1, current edition.

Authorities having jurisdiction should be consulted before installation.

The National Fuel Gas Code is available from:

American National Standard Institute Inc.
11 West 42nd Street
New York, NY 10036

These units are CSA International design certified. These unit heaters are certified for installation clearances to combustible material as listed in Table 1 and on unit rating plate. Accessibility and service clearances must be observed in addition to fire protection clearances.

All electrical wiring and ground for unit must be in accordance with the regulations of the current National Electric Code ANSI/NFPA No. 70.

The National Electric Code is available from:

National Fire Protection Association
1 Batterymarch Park
PO Box 9101
Quincy, MA 02269-9101

Requirements – CSA in Canada

The instructions are intended only as a general guide and do not supersede local codes in any way. Authorities having jurisdiction should be consulted before installation. The installation must conform with local building codes or in the absence of local codes, with the current code CSA-B149.1 "Installation Code for Natural Gas Burning Appliances and Equipment." All electrical wiring and grounding for the unit must also comply with the Canadian Electrical Code CSA C22.1, current edition.

These unit heaters are CSA International certified for the clearances to combustible material listed on the rating plate and Table 1. Adequate clearance shall be provided around the appliance and around air inlet terminals. Provision shall be made for service accessibility to the heater. Note that fire protection clearances may be exceeded to provide additional space for service and accessibility.

GARAGE INSTALLATIONS:

- 1- In a storage area, clearance from heaters to combustible materials must be such that the material shall not attain a temperature above 160°F by continuous operation of the unit.
- 2- Eight foot minimum clearance from the floor to the bottom of the heater must be maintained. Refer to the CSA-B149 Codes.

AIRCRAFT HANGER:

- 1- In an area where aircraft ft are housed or serviced, 10' minimum clearance from highest surface of aircraft ft to bottom of the heater must be maintained.
- 2- In other areas, 8' minimum clearance from the floor to bottom of heater must be maintained.
- 3- Heaters should be located so as to be protected from damage from aircraft ft or other appliances needed for servicing of aircraft. Refer to requirements of the enforcing authorities.

RESIDENTIAL INSTALLATIONS:

These units are approved for residential applications. Residential applications are defined as installations for heating non-living spaces that are attached to, adjacent to or part of a structure that contains space for family living quarters. For installation in a residential garage, these units must be installed so that burners and ignition source are located no less than 18" (457 mm) above floor. Heater must be located or protected to avoid physical damage by vehicles. Refer to CSA-B149.1, current edition.

Be sure to check with local codes and ordinances for additional requirements.

Unit Heater Installation

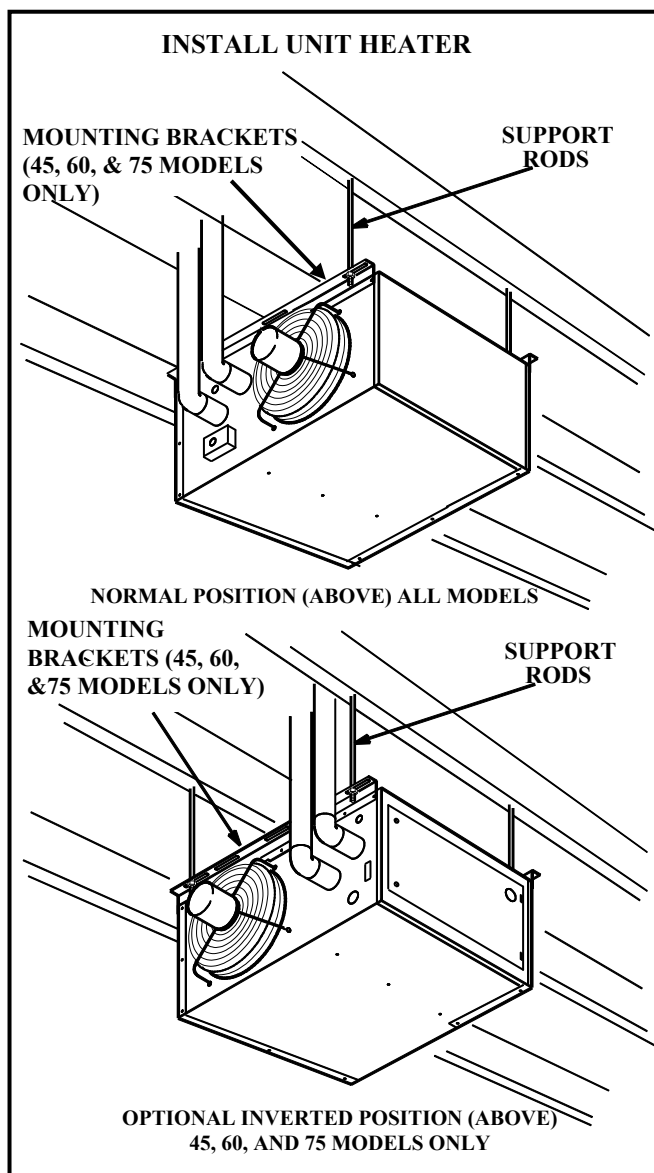

FIGURE 1

45, 60, and 75 size units may be installed in the normal position or inverted 180° as shown in Figure 1 depending on desired location as governed by clearances, vent connection, air direction, gas supply, electrical supply and service accessibility.

- 1- Rotate louvers directing airflow as desired.
- 2- Choose location for mounting brackets.
- 3- Remove the mounting brackets from their shipping location (attached to the top of the unit) and replace the screws that held the brackets in their shipping location.
- 4- Remove and retain screws along top edge (bottom edge when inverted) of front of unit.
- 5- Align screw holes on mounting bracket with holes along top edge (either upright or inverted) of unit.

Secure mounting brackets to unit with retained screws.

- 6- To support unit, secure mounting bracket to ceiling joist or truss. Unit may also hang on rods as shown in Figure 1.

100 and 125 size units may not be inverted, 3/8" X 16 threaded inserts are provided in the top the cabinet. Two threaded inserts are along one edge of the cabinet, two inserts are in the panel that divides the heat exchanger section from the control compartment.

- 1- Cut threaded rods to desired length and thread a 3/8" nut onto the rod.
- 2- Slide a flat washer onto the threaded rod AFTER the nut (7/16" I.D. X 1" O.D. X 1/16" THK washer).
- 3- Screw the rods (four) into the threaded inserts on the unit.
- 4- Tighten nuts to secure unit to rods.

Combustion and Ventilation Air

Adequate facilities for supplying air for combustion and ventilation must be provided. All gas fired appliances require air to be used for the combustion process. If sufficient quantities of combustion air are not available, the heater or another appliance will operate in an inefficient manner, resulting in incomplete combustion which can result in the production of excessive carbon monoxide.

CAUTION - *Insufficient combustion air can cause headaches, nausea, dizziness, asphyxiation or death.*

This unit must be provided with a combustion air pipe that is connected to the outside atmosphere. Outdoor air used for combustion must be free of the following substances or the life of the heat exchanger will be adversely affected: chlorine, carbon tetrachloride, cleaning solvent, halogen refrigerants, acids, cements and glues, printing inks, fluorides, paint removers, varnishes, or any other corrosives.

TABLE 2

MAXIMUM HORIZONTAL VENT LENGTHS

Model	45, 60, 75	100, 125
No. of Elbows	ft (M)	ft (M)
1	25 (7.6)	40 (12.2)
2	20 (6.1)	30 (9.1)
3	15 (4.6)	20(6.1)
4	10 (3.0)	10 (3.0)
5	5 (1.5)	15 (1.5)

Venting and Combustion Air Inlet

A-General Recommendations and Requirements

NOTE - The vent is a passageway, vertical or nearly so, used to convey flue gases from an appliance, or its vent connector, to the outside atmosphere. The vent connector is the pipe or duct that connects a fuel-gas burning appliance to a vent or chimney. The combustion air inlet is a pipe that connects the appliance to the outside atmosphere to convey oxygen from the air to the appliance burner.

Unit heaters must be vented in compliance with all local codes or requirements of the local utility, the current standards of the (American) National Fuel Gas Code, ANSI Z223.1 or (Canada) CSA-B149 Installation Codes, and the following instructions.

A vent connection flange and a combustion air pipe connection flange are attached to the back of the unit.

Single wall vent material shall have all seams and joints sealed with pressure sensitive aluminum tape or silicone rubber sealant. Aluminum tape must meet the provisions of SMACNA A FTS-100-73 Standards. The aluminum tape has a temperature rating of 400°F (204°C). Silicone rubber sealant must have a temperature rating of 482°F (250°C), i.e., Dow Corning RTV-736 or equivalent. All joints shall be secured with at least two corrosion resistant screws. All joints must be checked for gas tightness after installation.

Single wall vent shall not pass through any attic, interior wall, concealed space, or floor.

B-Vertical Vents Using Metal Vent Pipe- Commercial and Residential Installations

These separated combustion unit heaters are listed as Category I appliances for vertical vent installations.

- 1- These unit heaters are to be vented with NFPA- or ANSI- approved chimneys, U.L. listed type B-1 gas vents, single wall metal pipe, or listed chimney-lining system for gas venting where applicable, as well as the modifications and limitations listed in Figure 2. Seal single wall vent material according to the section **A-General Recommendations and Requirements**. Air inlet pipe may be single wall metal pipe or U.L. listed single wall metal flex connector. A concentric vent/adapter/cap kit as specified in these instructions may be used for vertical termination. Refer to Table 3.
- 2- The vent connector shall be 3" (76 mm) diameter on 45 units, 4" (100 mm) diameter on 60/75 units, and 5" (127 mm) on 100/125 units. The air inlet pipe

shall be 3" (76 mm) diameter on 45 units and 4" (100 mm) diameter on 60/75/100/125 units.

- 3- Keep the vent and air inlet runs as short as possible with a minimum number of elbows. Refer to the (American) National Fuel Gas Code ANSI Z223.1 or (Canada) CSA-B149 Installation Code for maximum vent and vent connector lengths. Horizontal run of the vent connector from the induced draft blower to the chimney/vent cannot exceed the values in Table 2. Single wall vent connector shall not be insulated.
- 4- If a single wall vent is used in an unheated area it shall be insulated with a minimum of 1/2" thick foil faced fiberglass 1-1/2 pound density insulation. Failure to do so will result in condensation of flue gases.
- 5- The unit may be vented vertically as a single appliance or as a common vent with other gas-fired appliances. In common venting situations, vent connectors for other appliances must maintain a 4" (100 mm) vertical separation between the vent connectors. Refer to common venting Tables in the (American) National Fuel Gas Code ANSI Z223.1 or (Canada) CSA-B149 Installation Code for proper vent size.
- 6- Clearance to combustible material is 6" (152 mm) for single wall vent material except where a listed clearance thimble is used. Clearance to combustible material for type B-1 vent or factory-built chimney is per manufacturer's instructions. Clearance to combustible material is 1" on vertical sections of the concentric vent/adapter/cap kit.
- 7- The vent connector shall be supported without any dips or sags. Vertical vents shall be supported in accordance with their listing and manufacturers' instructions. All horizontal vent connector runs shall have a slope up to the vertical vent of at least 1/4" per foot (1 mm per 50 mm).
- 8- All vertical type B-1 vents, single wall vents, or listed chimney lining system must be terminated with a listed vent cap or listed roof assembly.
- 9- The vent must extend at least 3' (1 m) above the highest point where it passes through a roof of a building and at least 2' (0.6 m) higher than any part of a building within a horizontal distance of 10' (3.05 m) unless otherwise specified by the (American) National Fuel Gas Code, ANSI Z223.1 or (Canada) CSA-B149 Installation Codes. The vent must extend at least 5' (1.6 m) above the highest connected equipment flue collar.

VENT AND AIR INTAKE TERMINATION ON SINGLE WALL VENT

SINGLE WALL TERMINATION

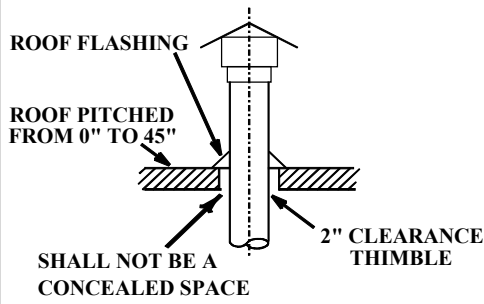

DOUBLE WALL (TYPE B-1) TERMINATION

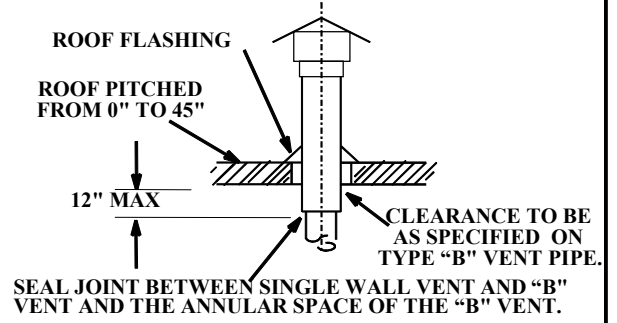

FIGURE 2

C-Horizontal Venting - General

Common venting is not allowed with horizontal vent.

The minimum horizontal vent length is three feet (914 mm).

- 1- If possible, do not terminate the horizontal vent through a wall that is exposed to prevailing wind. Exposure to excessive winds can affect unit performance. If such a termination is necessary, use a wind block to protect the vent termination from direct winds.
- 2- Vent termination must be free from obstructions and at least 12" (306 mm) above grade level and maximum snow height.
- 3- Do not terminate vent directly below roof eaves or above a walkway, or any other area where condensate dripping may be troublesome and may cause some staining. Avoid windows where steam may cause fogging or ice buildup.
- 4- When horizontally vented, minimum clearance for termination from any door, window, gravity air inlet, gas or electric meter, regulators, and relief equipment is 4 ft (1.2m) for U.S. installations. Refer to NFPA 54/ANSI Z223.1 in the U.S.A. and CSA B149.1 and .2 in Canada or with authorities having local jurisdiction. In Canada, vent termination must have a minimum 6 ft (1.8 mm) horizontal clearance from gas and electric meters and relief devices as specified in the Canadian B149.1, Natural Gas Installation Code.
- 5- Vent termination must be a minimum of 4' (1.2 m) below or 4' (1.2 m) horizontally from any soffit vent or under-eave vent.
- 6- Vent must be a minimum of 6' from an inside corner formed by two exterior walls. If possible, leave a 10' clearance.
- 7- Vent termination must be a minimum of 10' (3 m) from any forced air inlet (includes fresh air inlet for other appliances, such as a dryer).
- 8- When termination is routed through an exterior combustible wall the vent must be supported using a listed clearance thimble. Where local authorities permit, a single section of type B-1 vent pipe may be used as an alternative to the thimble. When using a type B-1 vent termination use the clearances specified by the vent manufacturer. Seal the connection between the single wall and double wall pipes and the annular space of the double wall pipe as shown in Figure 2. Inside edge of vent termination tee or Belmont cap must be at least 12" from outside wall as shown in Figure 3.
- 9- All horizontal vents must terminate with a tee or with a cap as specified in Table 4. Opening end of tee used

for termination must face downward. Addition of ¼" (6 mm) mesh corrosion resistant material as a bird screen in the tee or cap openings may be used.

- 9- For horizontal venting, the vent pipe shall be supported with hangers no more than 3 ft (1 m) apart to prevent movement after installation.
- 10- Clearance to combustible material is 6" (152 mm) for single wall vent material except where a listed clearance thimble is used. Clearance to combustible material for type B-1 vent or factory-built chimney is per manufacturer's instructions. Clearance to combustible material is 1" at the sides, 1" below, and 3" above on horizontal installations of the concentric vent/adapter/cap kit.

D-Horizontal Venting-Commercial

- 1- Horizontal commercial installations are for buildings that are not attached to living spaces. The vent may be single wall vent material installed according to the sections **Venting A-General Recommendations and Requirements** and **C-Horizontal Venting - General** and **D-Horizontal Venting - Commercial**. Refer to Figures 3, 4, and 5. The air inlet may be single wall vent material or U.L. listed single wall flex connector.
- 2- Refer to Table 2 for maximum vent lengths. The vent pipe diameter for horizontal commercial installations shall be 3" (76 mm) on 45 units, 4" (100 mm) on 60/75 units, 5" (127 mm) on 100/125 units. The air inlet diameter shall be 3" (76 mm) on 45/60/75 units and 4" (100 mm) on 100/125 units. Refer to Table 4 for diameter and termination requirements.
- 3- Select a wall termination point that will maintain ¼" rise per foot slope of horizontal run of vent pipe. The vent may be single wall material minimum 26 GSG (0.46 mm) galvanized steel or equivalent grade stainless steel. Seal single wall vent material according to the section **A-General Recommendations and Requirements**. In areas where local authorities having jurisdiction permit, a downward slope of maximum ¼" per foot is also acceptable. In such cases, the vent must be listed special vent for Category III appliances or single wall vent pipe constructed of number 26 GSG (0.46 mm) galvanized steel or equivalent grade stainless steel. Seal single wall vent material according to the section **A-General Recommendations and Requirements**. Condensate drainage can be collected in a tee pipe section (Figure 4) or allowed

to drip through the vent termination, if permitted by local authorities (Figure 5).

- 4- For upward sloped vent a condensate tee and drain must be installed within the first 5' (1.5 m) from the unit heater to protect the appliance. If a flexible condensate drain line is used, the drain line must

include a loop filled with water to prevent combustion products from entering the structure. If the unit is shut down for an extended period of time and will be exposed to sub-freezing temperatures, the condensate may freeze.

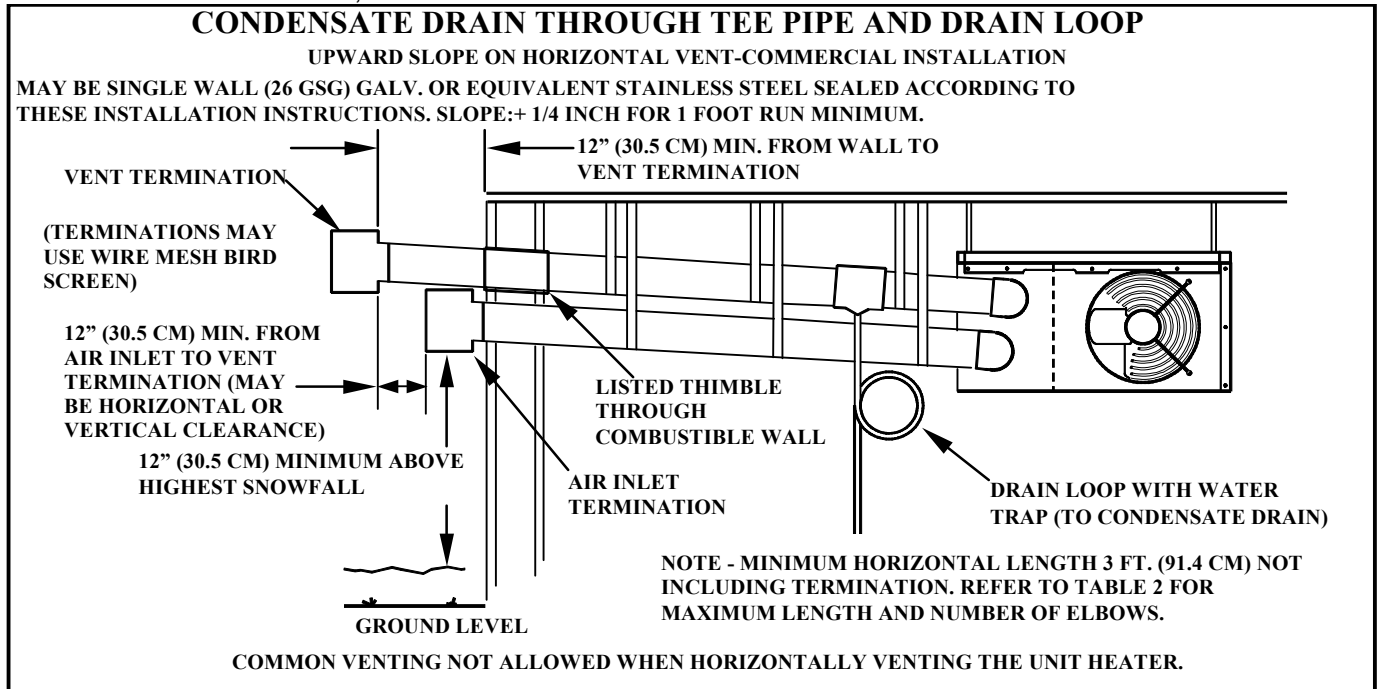

FIGURE 3

E-Horizontal Venting Concentric Kit - Commercial

1-Horizontal commercial installations are for buildings that are not attached to living spaces. The only concentric vent/adaptor/cap kit that may be used is the kit supplied by Advanced Distributor Products. The kit may be used with 45/60/75 units. The vent used to connect from the concentric adapter to the unit may be single wall material minimum 25 GSG (0.46 mm) galvanized steel or equivalent grade stainless steel installed according to the sections **Venting A-General Recommendations and Requirements** and **C-Horizontal Venting General** and **D-Horizontal Venting-Commercial** and **E-Horizontal Venting Concentric Kit - Commercial**.

The air inlet may be single wall material or U.L. listed single wall flex vent connector.

- 2-The vent pipe diameter for horizontal commercial installations shall be 3" (76 mm) on 45 units and 4" (100 mm) on 60/75 units. Refer to Table 4.
- 3-Refer to Table 2 for maximum vent lengths.
- 4-Refer to Figure 7 for kit termination, Figure 3 for upward slope with condensate trap, Figure 4 for downward slope with trap, and Figure 5 for downward slope with condensate drain through cap where permitted by local authorities.

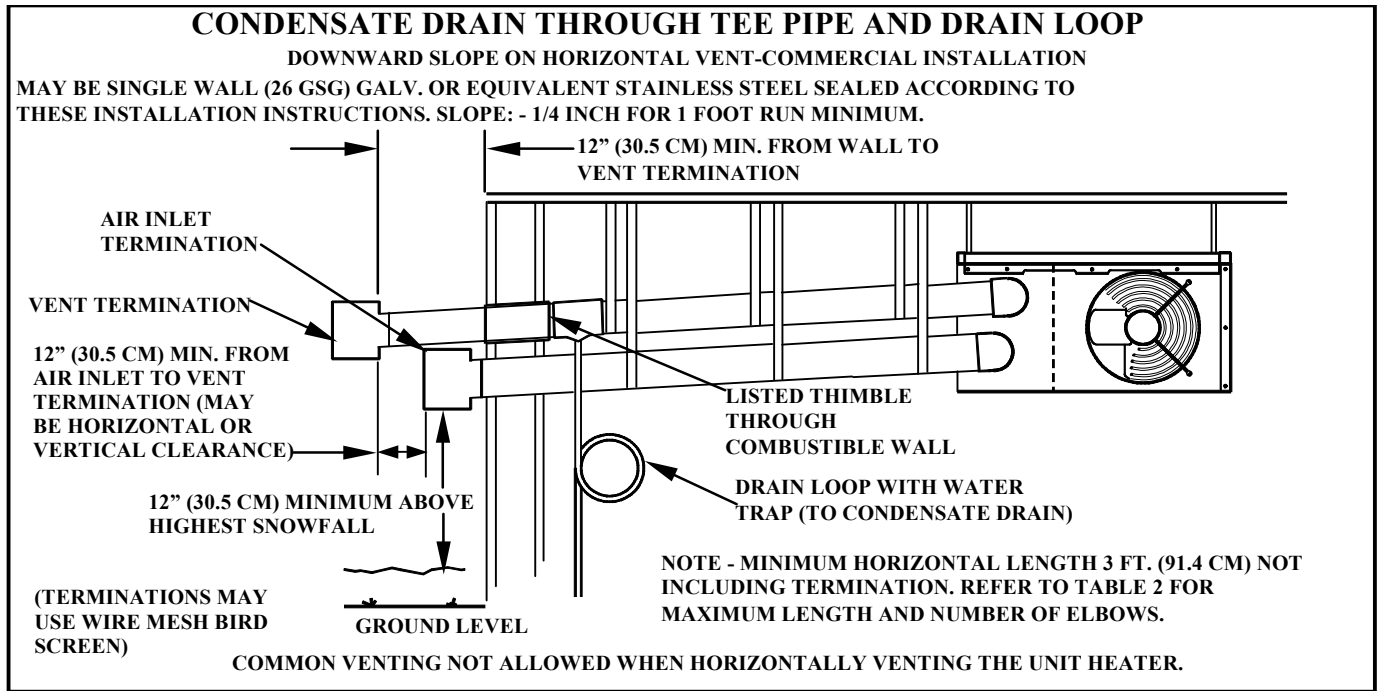

FIGURE 4

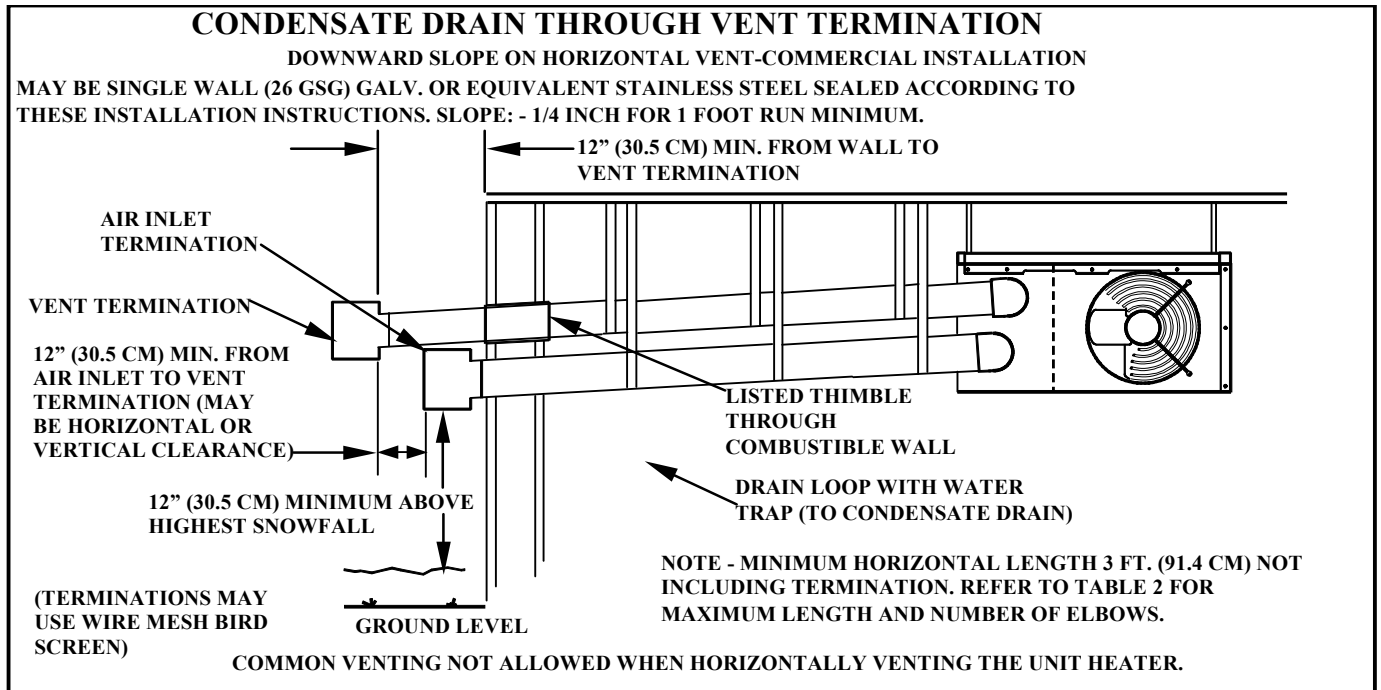

FIGURE 5

**TABLE 3
VERTICAL VENT REQUIREMENTS**

MODEL	INSTALLATION	FLUE TYPE	FLUE DIA.	AIR INLET DIA.	VENT CAP	OTHER
		AIR INLET TYPE				
45	COMMERCIAL or RESIDENTIAL	SINGLE WALL SINGLE WALL or METAL FLEX VENT	3"	3"	U.L. APPROVED	MAY USE ONE SECTION OF B-VENT
45	COMMERCIAL or RESIDENTIAL	TYPE B VENT SINGLE WALL or METAL FLEX VENT	3"	3"	U.L. APPROVED	
45	COMMERCIAL or RESIDENTIAL	CONCENTRIC SINGLE WALL or METAL FLEX VENT	3"	3"	4" CONCENTRIC VENT/ ADAPTER/CAP KIT REQUIRED	
60, 75	COMMERCIAL or RESIDENTIAL	SINGLE WALL SINGLE WALL or METAL FLEX VENT	4"	4"	U.L. APPROVED	MAY USE ONE SECTION OF B-VENT
60, 75	COMMERCIAL or RESIDENTIAL	TYPE B VENT SINGLE WALL or METAL FLEX VENT	4"	4"	U.L. APPROVED	
60, 75	COMMERCIAL or RESIDENTIAL	CONCENTRIC SINGLE WALL or METAL FLEX VENT	4"	4"	4" CONCENTRIC VENT/ ADAPTER/CAP KIT REQUIRED	
100, 125	COMMERCIAL or RESIDENTIAL	SINGLE WALL SINGLE WALL or METAL FLEX VENT	5"	4"	U.L. APPROVED	MAY USE ONE SECTION OF B-VENT
100, 125	COMMERCIAL or RESIDENTIAL	TYPE B VENT SINGLE WALL or METAL FLEX VENT	5"	4"	U.L. APPROVED	
100, 125	COMMERCIAL or RESIDENTIAL	CONCENTRIC SINGLE WALL or METAL FLEX VENT	5"	4"	5" CONCENTRIC VENT/ ADAPTER/CAP KIT REQUIRED	

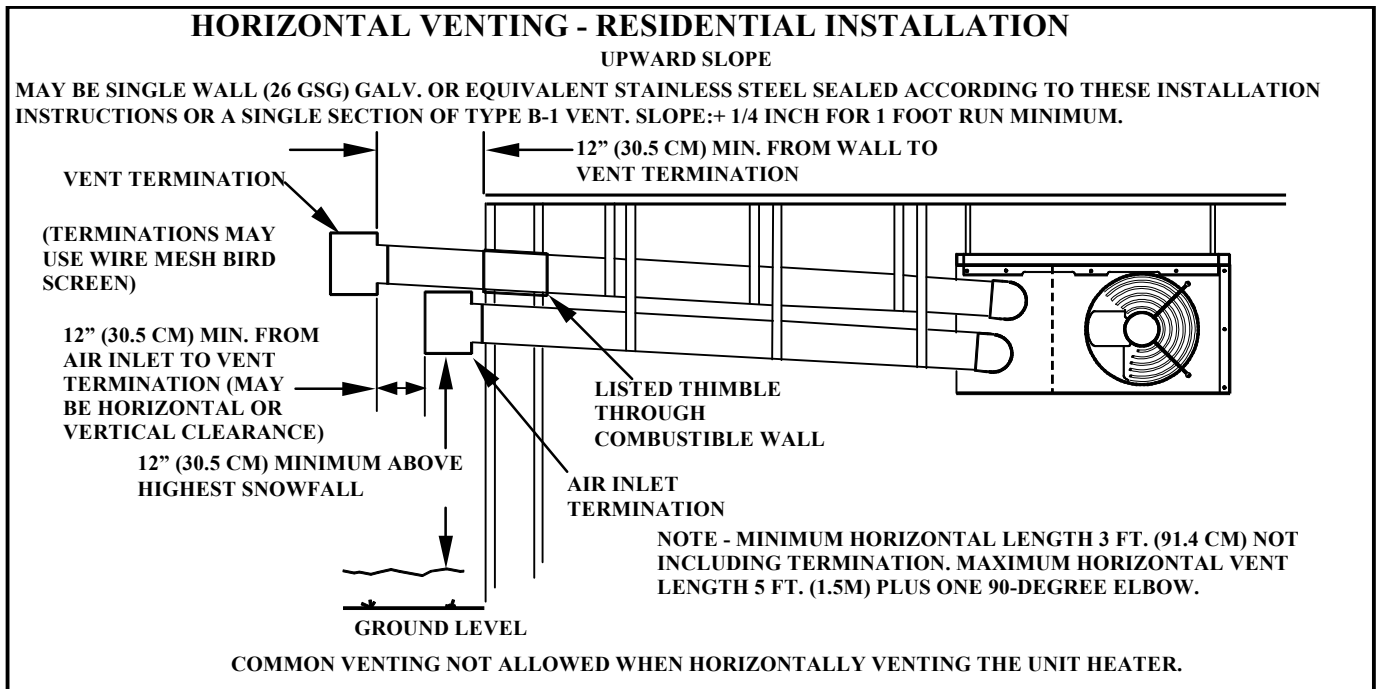

FIGURE 6

F-Horizontal Venting-Residential Two Pipes

1-For horizontal residential installations these units are certified as Category I appliances. The vent may be single wall material minimum 25 GSG (0.46 mm) galvanized steel or equivalent grade stainless steel or a single section of type B-1 vent installed according to the sections **Venting A-General Recommendations and Requirements** and **C-Horizontal Venting General** and **F-Horizontal Venting-Residential Two Pipes**. Refer to Figure 6.

2-The vent pipe diameter for horizontal residential installations shall be 4" (100 mm) on 45 units and 5" (127 mm) on 60/75/100/125 units. Refer to Table 4 for vent diameter and termination requirements.

3-The maximum vent length is 5' (1.5m) plus one 90-degree elbow.

4-The vent must maintain a ¼" rise per foot of slope upwards toward the termination

**TABLE 4
HORIZONTAL VENT REQUIREMENTS**

MODEL	INSTALLATION	FLUE TYPE	FLUE DIA.	VENT CAP	MAX. VENT LENGTH (MIN VENT LENGTH 3')
		AIR INLET TYPE	INLET AIR DIA.	INLET AIR CAP	
45	RESIDENTIAL	SINGLE WALL	4"	TEE or 065340602 BELMONT	5' MAY USE ONE SECTION OF B-VENT
		SINGLE WALL PIPE or METAL FLEX VENT	3"	TEE or 065340601 BELMONT	
45	RESIDENTIAL	CONCENTRIC	4"	4" CONCENTRIC VENT/ ADAPTER/CAP KIT REQUIRED	5'
		SINGLE WALL PIPE or METAL FLEX VENT	3"		
45	CO MMERCIAL	SINGLE WALL	3"	TEE or 065340601 BELMONT	25' MAY USE ONE SECTION OF B-VENT
		SINGLE WALL PIPE or METAL FLEX VENT	3"	TEE or 065340601 BELMONT	
45	CO MMERCIAL	CONCENTRIC	3"	4" CONCENTRIC VENT/ ADAPTER/CAP KIT REQUIRED	25'
		SINGLE WALL PIPE or METAL FLEX VENT	3"		
60, 75	RESIDENTIAL	SINGLE WALL	5"	TEE or 065340603 BELMONT	5' MAY USE ONE SECTION OF B-VENT
		SINGLE WALL PIPE or METAL FLEX VENT	4"	TEE or 065340602 BELMONT	
60, 75	RESIDENTIAL	CONCENTRIC	4"	4" CONCENTRIC VENT/ ADAPTER/CAP KIT REQUIRED	5'
		SINGLE WALL PIPE or METAL FLEX VENT	4"		
60, 75	CO MMERCIAL	SINGLE WALL	4"	TEE or 065340602 BELMONT	25' MAY USE ONE SECTION OF B-VENT
		SINGLE WALL PIPE or METAL FLEX VENT	4"	TEE or 065340602 BELMONT	
60, 75	CO MMERCIAL	CONCENTRIC	4"	4" CONCENTRIC VENT/ ADAPTER/CAP KIT REQUIRED	25'
		SINGLE WALL PIPE or METAL FLEX VENT	4"		
100, 125	RESIDENTIAL	SINGLE WALL	5"	TEE or 065340603 BELMONT	5' MAY USE ONE SECTION OF B-VENT
		SINGLE WALL PIPE or METAL FLEX VENT	4"	TEE or 065340602 BELMONT	
100, 125	CO MMERCIAL	SINGLE WALL	5"	TEE or 065340603 BELMONT	5' MAY USE ONE SECTION OF B-VENT
		SINGLE WALL PIPE or METAL FLEX VENT	4"	TEE or 065340602 BELMONT	

G-Horizontal Venting Concentric Kit - Residential

1-For horizontal residential installations the 45/60/75 units are certified as Category I appliances with a concentric vent/adapter/cap kit. The only concentric vent/adapter/cap kits that may be used are the kits supplied by Advanced Distributor Products. The vent used to connect from the concentric adapter to the unit may be single wall material minimum 25 GSG (0.46 mm) galvanized steel or equivalent grade stainless steel installed according to the sections **Venting A - General Recommendations and Requirements** and **C - Horizontal Venting General**

and **G - Horizontal Venting Concentric Kit - Residential**. Refer to Figure 7. The air inlet may be single wall material or U.L. listed single wall flex vent connector.

- 2-The vent pipe diameter for horizontal residential installations shall be 4" (100 mm) on 45/60/75 units. Refer to Table 4.
- 3-The maximum vent length is 5' (1.5m) plus one 90-degree elbow.
- 4-The vent must maintain a ¼" rise per foot of slope upwards toward the termination.

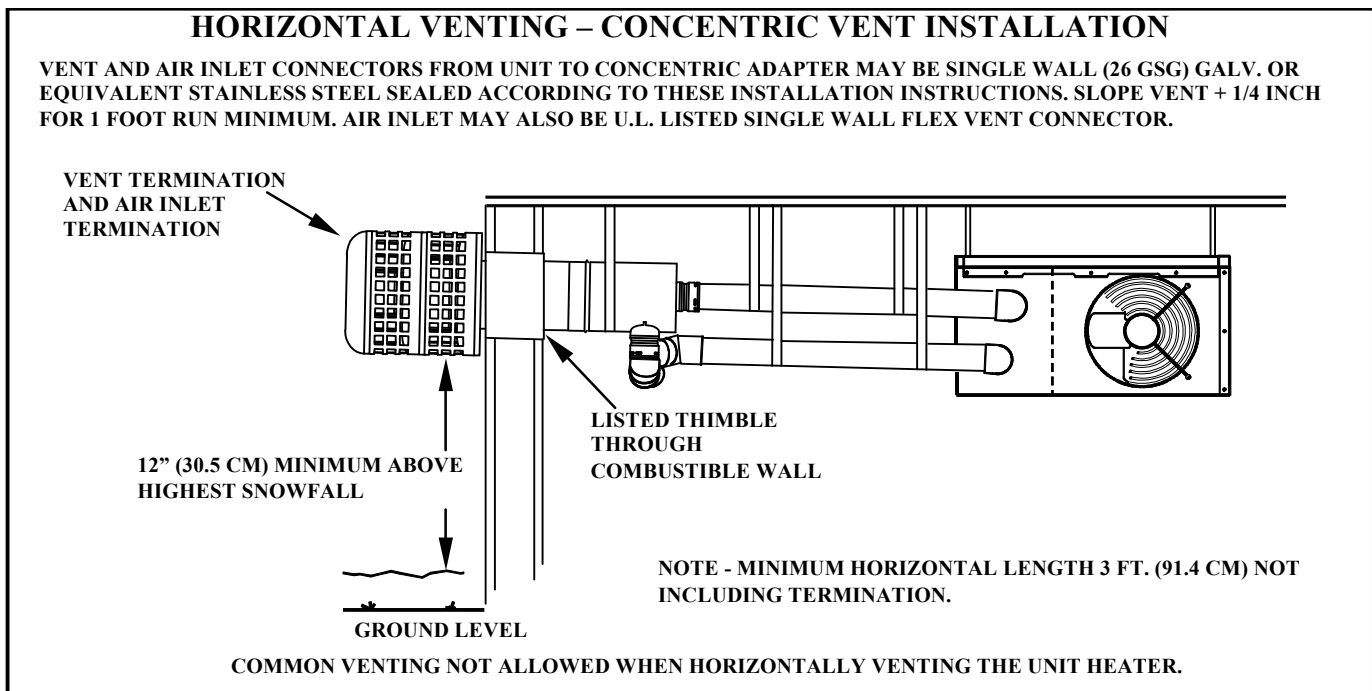

FIGURE 7

Electrical Connections

NOTE - These unit heaters use a direct spark ignition system. There is no pilot necessary as the spark lights the main burner as the gas valve is turned on. The direct spark ignition control board emits radio noise as the sparking process is underway. The level of energy may be sufficient to disturb a logic circuit in a microprocessor controlled thermostat. It is recommended that an isolation relay be used when connecting the unit heaters to a microprocessor-controlled thermostat. Install the thermostat according to instructions provided. Select circuit protection and wire size according to the unit rating plate. Install a separate disconnect switch (protected by either fuse or circuit breaker) near the unit so that power can be turned off for servicing. Connect wiring through knockout on the junction box located on the side of the unit heater. Refer to heater wiring

diagram for connection information. Use 18 gauge wire or larger for thermostat connections.

Electrically ground unit in accordance with local codes or, in the absence of local codes, in accordance with the current National Electrical Code (ANSI/NFPA No. 70) in the U.S.A., and in Canada with the current Canadian Electrical Code, Part 1 (CSA C22.1).

Make line voltage connections as shown in Figure 8. Connect field wiring as shown on wiring diagram on unit. Also refer to typical diagram in this manual. An additional thermostat wire must be run to terminal "G" on heater when continuous blower is desired.

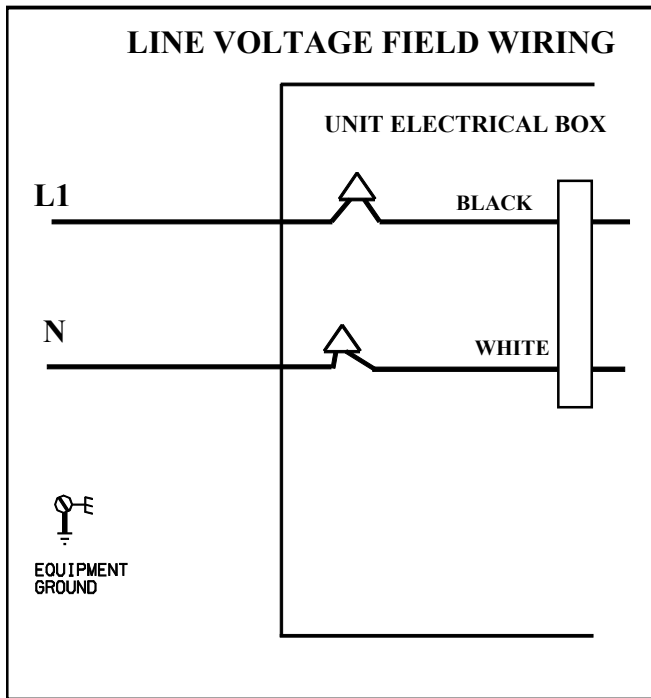

FIGURE 8

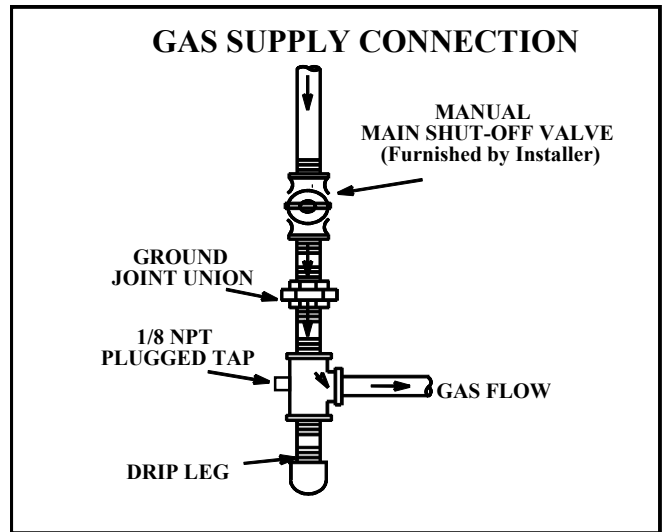

FIGURE 9

Leak Check

After gas piping is completed, carefully check all piping connections, (field and factory), for gas leaks. Use a soap solution or other preferred means.

CAUTION - DO NOT use matches, candles, flame or other sources of ignition to check for gas leaks.

IMPORTANT - The heater and its individual shut off valve must be disconnected from the gas supply piping system during any pressure testing of that system at test pressures in excess of 1/2 psig (3.45 kPa).

The appliance must be isolated from the gas supply piping system by closing its individual manual gas shutoff valve during any pressure testing of the gas supply system at test pressures equal to or less than 1/2 psig (3.45 kPa). See Figure 10.

NOTE - In case emergency shutdown is required, shut down main gas valve and disconnect main power to unit. These devices should be properly labeled by the installer.

Gas Connection

When connecting gas supply, the length of the run from the meter must be considered in determining the pipe size to avoid excessive pressure drop. A line pressure of 7" w.c. (1.74 kPa) for natural gas should be maintained when sizing piping. A line pressure of 13" w.c. (3.23 kPa) should be maintained for liquefied petroleum (LP) gas. For correct sizing of piping, refer to the (American) National Fuel Gas Code ANSI Z223.1 or (Canada) CSA-B149 Installation Code or consult the utility having jurisdiction.

A drip leg should be installed in the vertical pipe run to the unit. In some localities, codes may require that a manual main shutoff valve and union (furnished by installer) be installed external to the unit. Union must be of the ground joint type. A drip leg should be readily accessible to permit cleaning and emptying. See Figure 9. Leave a minimum of 4" (102 mm) clearance between electric box and drip leg.

A 1/8" NPT plugged tap shall be installed immediately upstream of the gas supply connection to the heater.

NOTE - Compounds used on threaded joints of gas piping must be resistant to the actions of liquefied petroleum gases.

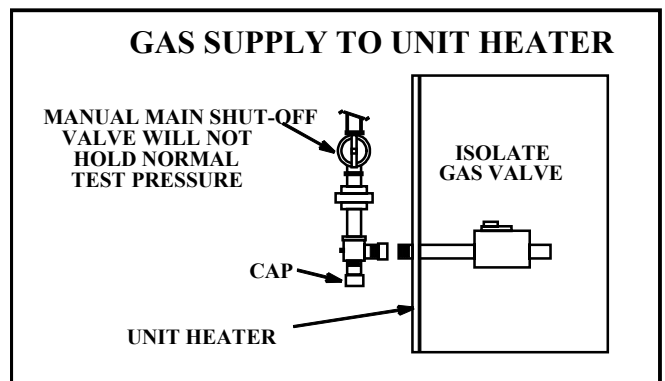

FIGURE 10

START-UP AND OPERATION

Unit Start-Up

FOR YOUR SAFETY READ BEFORE LIGHTING

! WARNING



Electric shock hazard. Can cause injury or death. Do not use this heater if any part has been under water. Immediately call a qualified service technician to inspect the furnace and to replace any part of the control system and any gas control which has been under water.

! WARNING



Danger of explosion. Can cause injury or product or property damage. If overheating occurs or if gas supply fails to shut off, shut off the manual gas valve to the appliance before shutting off electrical supply.

! WARNING



Electric shock hazard. Can cause injury or death. Before attempting to perform any service or maintenance, turn the electrical power to unit OFF at disconnect switch(es). Unit may have multiple power supplies.

! WARNING



Danger of explosion and fire. Can cause injury or product or property damage. You must follow these instructions exactly.

BEFORE LIGHTING smell all around the appliance area for gas. Be sure to smell next to the floor because some gas is heavier than air and will settle on the floor.

Use only your hand to push in or turn the gas control knob. Never use tools. If the knob will not push in or turn by hand, do not try to repair it, call a qualified service technician. Force or attempted repair may result in a fire or explosion.

These unit heaters are equipped with an automatic spark ignition system. There is no pilot. In case of a safety shutdown, move thermostat switch to **OFF**, then return the thermostat switch to **HEAT** position.

Operation for Honeywell VR8205 Series Gas Valve (Figure 11)

- 1- **STOP!** Read the safety information at the beginning of this section.
- 2- Set thermostat to lowest setting.

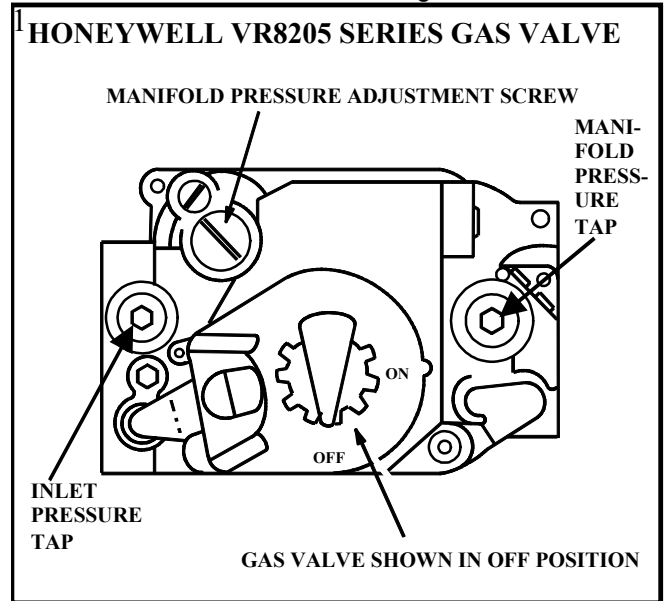

FIGURE 11

- 3-Turn off all electrical power to appliance.
- 4-This appliance is equipped with an ignition device which automatically lights burners. **DO NOT attempt to light the burners manually.**
- 5-Turn the manual knob on gas valve clockwise to **OFF**. Do not force.
- 6-Wait five (5) minutes to clear out any gas. If you then smell gas, **STOP!** Immediately call your gas supplier from a neighbor's phone. Follow the gas supplier's instructions. If you do not smell gas, go to next step.
- 7-Turn manual knob on gas valve counterclockwise to **ON**.
- 8-Close the unit door.
- 9-Turn on all electric power to unit.
- 10- Set thermostat to desired setting.
- 11- The combustion air blower will start. The burners will light within 40 seconds.
- 12- If unit does not light first time (gas line not fully purged) it will attempt up to two more ignitions before locking out.
- 13- If lockout occurs, repeat steps 1 through 10.
- 14- If appliance still will not operate, follow the instructions "**To Turn Off Gas to Unit**" and call your service technician or gas supplier.

Gas Valve Operation for White Rodgers 36E Series Valve (Figure 12)

- 1- **STOP!** Read the safety information at the beginning of this section.
- 2- Set thermostat to lowest setting.
- 3- Turn off all electrical power to appliance.
- 4- This appliance is equipped with an ignition device which automatically lights burner. **DO NOT attempt to light the burners manually.**

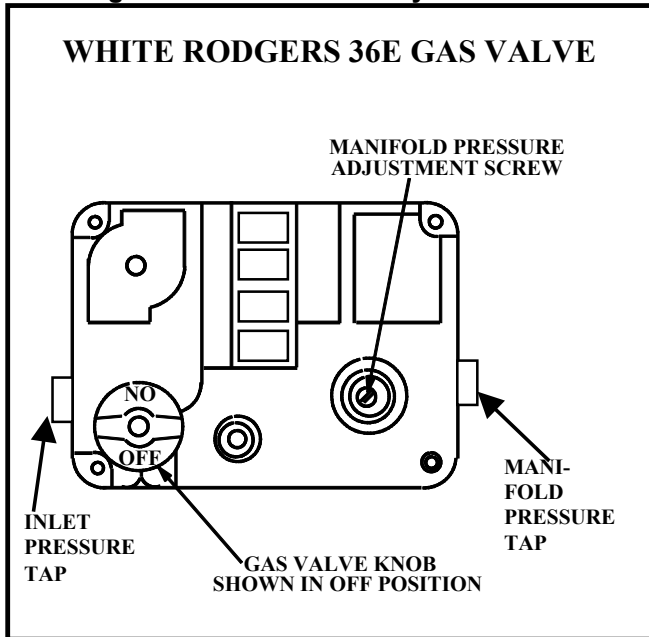

FIGURE 12

- 5- Turn knob on gas valve 180° either way to **OFF**.
- 6- Wait five minutes to clear out any gas. If you then smell gas, **STOP!** Immediately call your gas supplier from a neighbor's phone. Follow the gas supplier's instructions. If you do not smell gas go to next step.
- 7- Turn knob on gas valve 180° either way to **ON**.
- 8- Close unit door.
- 9- Turn on electrical power to unit.
- 10-Set thermostat to desired setting.
- 11- The combustion air blower will start. The burners will light within 40 seconds.
- 12-If unit does not light first time (gas line not fully purged) it will attempt up to two more ignitions before locking out.
- 13-If lockout occurs, repeat steps 1 through 10.
- 14-If appliance still will not operate, follow the instructions "**To Turn Off Gas to Unit**" and call your service technician or gas supplier.

Gas Valve Operation for Robert Shaw 2000DER Series Valve (Figure 13)

- 1- **STOP!** Read the safety information at the beginning of this section.
- 2- Set the thermostat to lowest setting.
- 3- Turn off all electrical power to appliance.
- 4- This appliance is equipped with an ignition device which automatically lights burner. **DO NOT attempt to light the burners manually.**

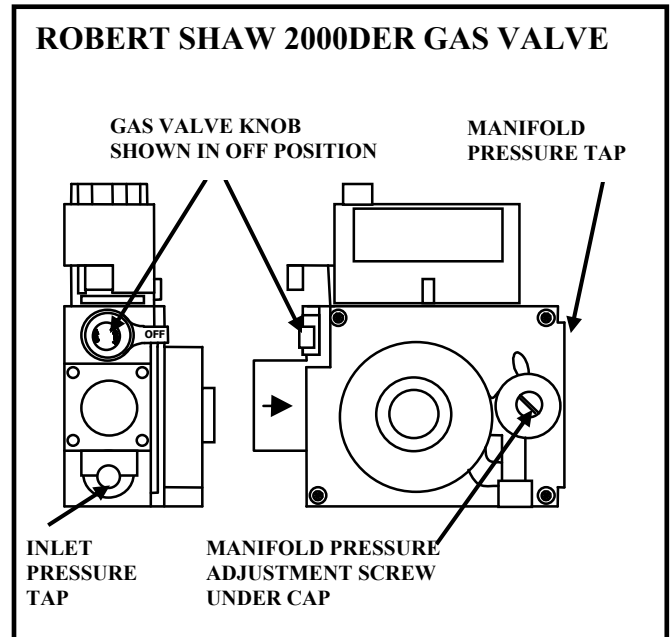

FIGURE 13

- 5- Depress knob on gas valve; knob will snap to **OFF**.
- 6- Wait five minutes to clear out any gas. If you then smell gas, **STOP!** Immediately call your gas supplier from a neighbor's phone. Follow the gas supplier's instructions. If you do not smell gas go to next step.
- 7- Turn knob on gas valve 90° counterclockwise to **ON**.
- 8- Close unit door.
- 9- Turn on electrical power to unit.
- 10-Set the thermostat to desired setting.
- 11-The combustion air blower will start. The burners will light within 40 seconds.
- 12-If unit does not light first time (gas line not fully purged) it will attempt up to two more ignitions before locking out.
- 13-If lockout occurs, repeat steps 1 through 10.
- 14-If appliance still will not operate, follow the instructions "**To Turn Off Gas to Unit**" and call your service technician or gas supplier.

To Turn Off Gas To Unit

- 1- Set thermostat to lowest level.
- 2- Turn off all electrical power to unit if service is to be performed.
- 3- *Honeywell VR8205 series valve*: turn knob on gas valve 90° clockwise to **OFF**.
White Rodgers 36E series valves: turn knob on gas valve 180° either way to **OFF**.
Robert Shaw DER2000 series valves: depress knob on gas valve; knob will snap to **OFF**.

Heating Sequence of Operation

- 1- When the thermostat calls for heat, the combustion air blower starts immediately.
- 2- Combustion air pressure switch proves blower operation before allowing power to the ignition controller. This switch is factory set and no adjustment is necessary.
- 3- After prepurge of approximately 30 seconds, the spark ignition is energized and the solenoid valves open in the gas valve.
- 4- The spark then ignites the gas, the ignition sensor proves the flame and the combustion process continues.
- 5- In the event that the flame is not detected after the first 10-second trial for ignition, the controller will repeat steps 3 and 4 an additional two times before locking out the gas valve. Ignition control will then automatically repeat steps 3, 4, and 5 after 60 minutes.
To interrupt the 60-minute lockout period, move thermostat from "Heat" to "OFF" then back to "Heat." Heating sequence then restarts at step 1.
- 6- The burners shall light without noticeable crossover delay. There shall be no flame lifting from the burner heads, flashback or burning within the burner. The flames shall be predominantly blue in color and shall be approximately centered in the tubes with no apparent impingement taking place.
- 7- The ignition control will energize the fan approximately 45 seconds after ignition is established.
- 8- After the thermostat demand is satisfied the gas valve is closed; 5 seconds after the demand is satisfied the combustion air blower is shut off.
- 9- The control center shall shut off the system fan approximately 120 seconds after the gas valve is de-energized.

Ignition Control LED

The ignition control board contains a green LED which indicates the following:

TABLE 5
IGNITION CONTROL LED

LED	UNIT OPERATION
Slow Flash*	Normal Operation - No call for heat
Fast Flash	Normal Operation - Call for heat Current signal at FLAME terminal 0.6 to 1.0 microamps
2 Flashes	System lockout - failed to detect or sustain flame Current signal at FLAME terminal <0.6 microamps
3 Flashes	Pressure switch failed closed before CAB is energized or failed open after CAB is energized
4 Flashes	High limit or rollout switch open
5 Flashes	Flame sensed and gas valve not energized
Steady Off	Loss of power
Steady On	Ignition control failure

*When thermostat is placed in continuous fan mode LED will slowly flash.

Optional Gas Conversion Kit

A natural to LP/propane gas changeover kit is required to convert unit. Refer to the installation instructions supplied with the changeover kit for conversion procedure.

For models FOAN-45, 60, & 75 order propane conversion kit number 065336301. For models FOAN-100, & 125 order propane conversion kit number 065336302.

ADJUSTMENTS

High Altitude

Units may be fired at full input up to 2000 ft (610 m) above sea level. Above 2000 ft (610 m), manifold pressure must be reduced by 4% for each 1000 feet above sea level or as specified by local authority having jurisdiction. Adjust pressure regulator to pressure shown in Table 6 for natural gas and Table 7 for LP/propane gas. The combustion air blower proving switch is factory set. No adjustment is necessary.

Gas Pressure

Check gas line pressure with unit firing at maximum rate. A minimum of 5.0" w.c. for natural gas or 10.4" w.c. for LP/propane gas should be maintained for proper unit operation. After line pressure has been checked and adjusted, check manifold pressure. Correct manifold pressure is shown on the unit rating plate. See Figures 11, 12 and 13 for gas pressure adjustment screw location. A natural gas to LP/propane gas changeover kit is required to convert unit. Refer to installation instructions provided with changeover kit for conversion procedure.

Limit Control

The limit control switch is factory set and not field adjustable.

Louver Vane Adjustment

Rotate louver vanes to direct airflow upward, downward, straight, or any combination of these directions.

Combustion Air Pressure Switch

This pressure switch checks for proper combustion air blower operation before allowing an ignition trial. The switch is factory set and no field adjustment is necessary.

Flame Rollout Switch

The flame rollout switch(es) on 45, 60 or 75 units are located on the burner box top, behind the ignition control board. The flame rollout switch on 100 or 125 units is located on the manifold bracket above the top burner. This normally closed switch opens on a temperature rise. Check for adequate combustion air and proper venting before manually resetting switch.

**TABLE 6
NATURAL GAS MANIFOLD PRESSURES - in wg. (kPa)**

MODEL	ALTITUDE FT (M)								
	0-2000 (0-610)	2001-3000 (610-914)	3001-4000 (915-1219)	4001-5000 (1220-1524)	5001-6000 (1524-1829)	6001-7000 (1829-2134)	7001-8000 (2134-2438)	8001-9000 (2439-2743)	9001-10000 (2744-3048)
45	3.5 (0.87)*	2.7 (0.67)	2.5 (0.62)	2.2 (0.55)	2.0 (0.50)	1.8 (0.45)	1.6 (0.40)	1.4 (0.35)	1.3 (0.32)
60	3.5 (0.87)*	2.7 (0.67)	2.5 (0.62)	2.2 (0.55)	2.0 (0.50)	1.8 (0.45)	1.6 (0.40)	1.4 (0.35)	1.3 (0.32)
75	3.5 (0.87)*	2.7 (0.67)	2.5 (0.62)	2.2 (0.55)	2.0 (0.50)	1.8 (0.45)	1.6 (0.40)	1.4 (0.35)	1.3 (0.32)
100	3.5 (0.87)*	3.5 (0.87)*	3.5 (0.87)*	2.2 (0.55)	2.0 (0.50)	1.8 (0.45)	1.6 (0.40)	1.4 (0.35)	1.3 (0.32)
125	3.5 (0.87)*	2.7 (0.67)	2.5 (0.62)	2.2 (0.55)	2.0 (0.50)	1.8 (0.45)	1.6 (0.40)	1.4 (0.35)	1.3 (0.32)

*No adjustment required.

TABLE 7
LP/PROPANE GAS MANIFOLD PRESSURES - in wg. (kPa)

MODEL	ALTITUDE FT (M)								
	0-2000 (0-610)	2001-3000 (610-914)	3001-4000 (915-1219)	4001-5000 (1220-1524)	5001-6000 (1524-1829)	6001-7000 (1829-2134)	7001-8000 (2134-2438)	8001-9000 (2439-2743)	9001-10000 (2744-3048)
45	9.5 (2.37)*	9.5 (2.37)*	9.5 (2.37)*	6.1 (1.52)	5.5 (1.37)	4.9 (1.22)	4.4 (1.10)	3.9 (0.97)	3.4 (0.85)
60	9.5 (2.37)*	9.5 (2.37)*	9.5 (2.37)*	6.1 (1.52)	5.5 (1.37)	4.9 (1.22)	4.4 (1.10)	3.9 (0.97)	3.4 (0.85)
75	9.5 (2.37)*	7.0 (1.74)	6.4 (1.59)	6.1 (1.52)	5.5 (1.37)	4.9 (1.22)	4.4 (1.10)	3.9 (0.97)	3.4 (0.85)
100	9.0 (2.24)*	9.0 (2.24)*	9.0 (2.24)*	5.8 (1.44)	5.2 (1.30)	4.7 (1.17)	4.2 (1.05)	3.7 (0.92)	3.2 (0.80)
125	9.0 (2.24)*	9.0 (2.24)*	9.0 (2.24)*	5.8 (1.44)	5.2 (1.30)	4.7 (1.17)	4.2 (1.05)	3.7 (0.92)	3.2 (0.80)

*No adjustment required.

Gas Flow

Check for proper gas flow to the unit heater.

1. Operate unit at least 15 minutes before checking gas flow. Determine the time in seconds for one revolution of gas through the meter.
2. Compare the number of seconds and the gas meter size in Table 8 to determine the gas flow rate. Multiply the gas flow rate by the heating value to determine the unit input rate. If manifold pressure is correct and the unit input rate is incorrect, check gas orifices for proper size and restriction.

NOTE – To obtain accurate reading, shut off all other gas appliances connected to meter.

TABLE 8

Gas Flow Rate (ft ³ /Hr.)		
Seconds for 1 Revolution	Gas Meter Size	
	½ cu ft Dial	1 cu ft Dial
10	180	360
12	150	300
14	129	257
16	113	225
18	100	200
20	90	180
22	82	164
24	75	150
26	69	138
28	64	129
30	60	120
32	56	113
34	53	106
36	50	100
38	47	95
40	45	90
42	43	86
44	41	82
46	39	78
48	38	75
50	36	72
52	35	69
54	33	67
56	32	64
58	31	62
60	30	60

SERVICE

CAUTION - Turn off gas and electrical power to unit before performing any maintenance or service operations on this unit. Remember to follow lighting instructions when putting unit back into operation after service or maintenance.

Burners

- 1- Periodically examine burner flames for proper appearance during the heating season.
- 2- Before each heating season examine the burners for any deposits or blockage that may have occurred.
- 3- Clean burners as follows:
 - a-Turn off both electrical and gas supplies to unit.
 - b-Disconnect gas supply piping, high tension and sensor leads. Remove gas manifold. Remove burner tray.
 - c-Clean burners as necessary. Make sure that burner heads line up properly to ensure flame crossover. Check spark gap on electrode and adjust if required. The gap should be between 0.110" and 0.140" (2.79 mm to 3.56 mm). The gap may be checked with appropriately sized twist drills or feeler gauges.
 - d-Reinstall burner tray, gas manifold, high tension and sensor leads. Reconnect gas supply piping.
 - e-Restore electrical power and gas supply. Follow lighting instructions to light unit. Check burner flame.

Flue Passageway and Flue Box

The flue passages and flue box should be inspected and cleaned prior to each heating season. The sequence of operation should be as follows:

- 1- Turn off both electrical and gas supply to unit.
- 2- Disconnect combustion air blower wiring.
- 3- Remove screws securing flue box to unit. Remove flue box. If necessary, remove blower assembly from flue box. Clean flue box with wire brush.
- 4- Remove turbulator retention bracket and turbulators. Clean turbulators with wire brush.
- 5- Remove burners as described in section "Burners" section.
- 6- Clean tubes with a wire brush.
- 7- Reassemble unit. The combustion air and flue box gaskets should also be replaced during reassembly.
- 8- Restore electrical power and gas supply. Follow lighting instructions to light unit. Check operation of unit.

Combustion Air Blower

Under normal operating conditions, the combustion air blower should be checked and cleaned prior to the heating season with the power supply disconnected. Use a small brush to clean blower wheel.

Electrical

- 1- Check all wiring for loose connections.
- 2- Check for correct voltage at unit (unit operating).
- 3- Check amperage draw.

Flue and Air Inlet

Check all vent and air inlet joints for tightness. Ensure that connections are sealed and that there are no blockages.

Failure to Operate

If unit fails to operate check the following:

- 1- Is thermostat calling for heat?
- 2- Is main disconnect closed?
- 3- Is there a breaker tripped or a fuse blown?
- 4- Is gas turned on at meter?
- 5- Is manual shutoff valve open?
- 6- Is unit ignition system in lock out? If unit locks out again, call service technician to inspect unit.
- 7- Is pressure switch closed? Obstructed flue will cause unit to shut off at pressure switch. Check flue passage and outlet.

Repair Parts

When ordering repair parts include the complete unit model number listed on the unit rating plate. For example: FOAN-45-1-1-1.

△ MAXIMUM LOAD NOT TO EXCEED
20 VA AT 24 V CLASS 2.

△ (2) S47 USED ON 60 & 75 MODELS
ONLY.

DISCONNECT ALL POWER
BEFORE SERVICING.

FOR PROPER GROUNDING REFER
TO LOCAL CODES.

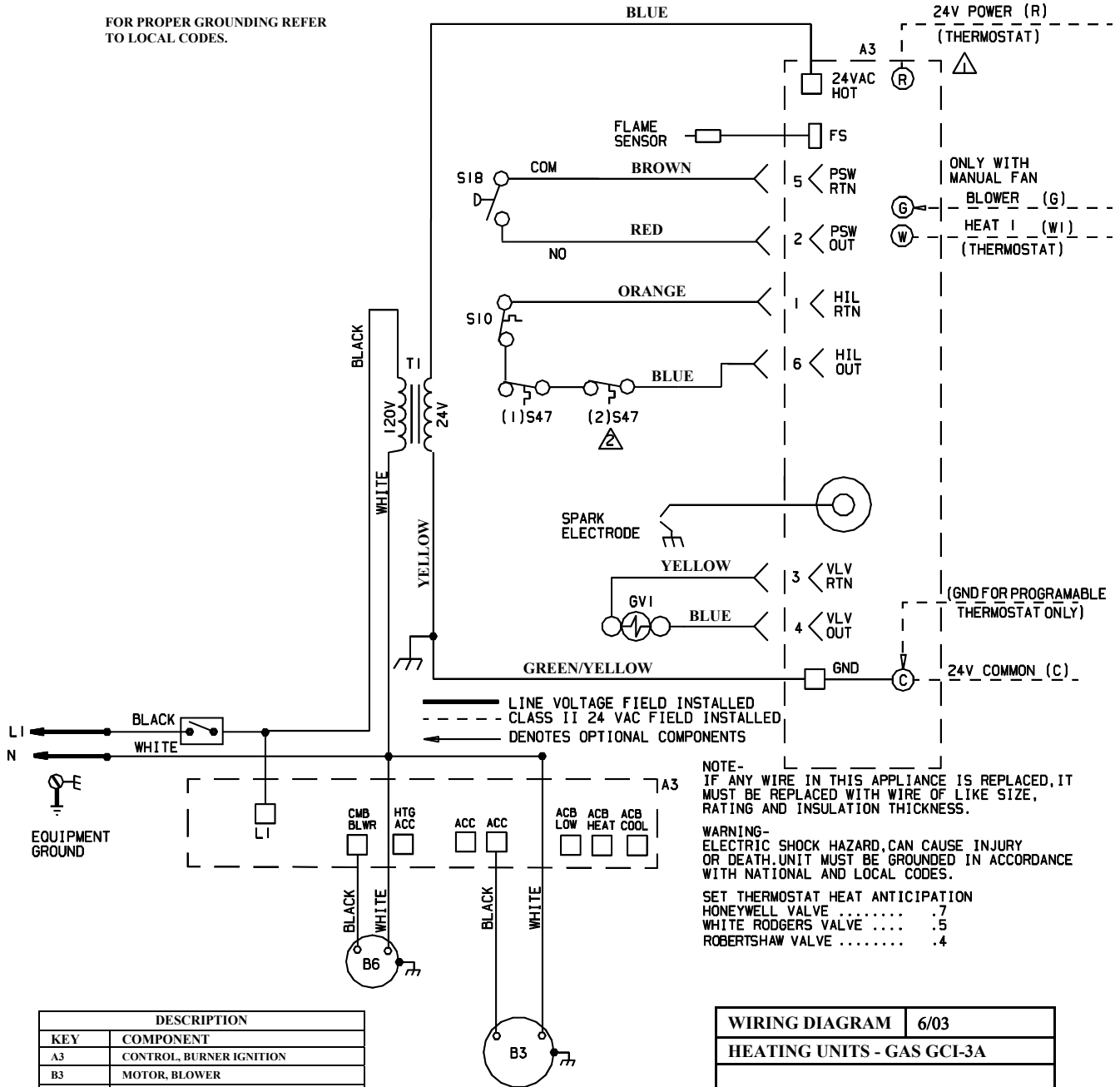

WIRING DIAGRAM	6/03
HEATING UNITS - GAS GCI-3A	
FO(A,S)(N,P)-45/60/75/100/125	
Supersedes Form No.	New Form No. 065329500



Unit Heater Limited Warranty – Standard 2 Year

(Applies only to product installed within the United States or Canada)

Term of Standard Warranty: Advanced Distributor Products (ADP) warrants that products sold shall be of merchantable quality, free of defects in material and workmanship, under normal use and service, for a period of two (2) years from the date of installation, **not** to exceed three (3) years from the date of manufacture.

Extended Components: This warranty provides extended coverage on Aluminized Heat Exchangers for **ten (10) years** and Stainless Steel Heat Exchangers for **fifteen (15) years**. The extended warranty coverage begins with the installation date and represents the total warranty period for the specific component. ADP, at its option, will furnish a replacement heat exchanger or allow a credit (in the amount of the heat exchanger original selling price) toward the purchase of a new ADP unit heater. **No extended coverage** granted for **HED series** heat exchangers.

Warranty Procedure: Warranty parts should be replaced by a qualified local contractor or dealer and will require the following information: model number, serial number, date of installation and an accurate description of the problem. Contractor or dealer will contact a local ADP distributor for replacement parts.

Replacement Parts: If, during the term of this warranty, a warranted part fails, ADP will either provide a replacement part free of charge, or may at its option, grant a credit for the original purchase price of the defective article to a distributor of ADP products. ADP may require the return of a defective article for factory inspection to verify and/or determine the root cause of the failure. Covered components include all parts of this unit except for the following **excluded components**, which are not covered by this warranty: cabinet, cabinet pieces, wiring and wiring harnesses.

Care of Equipment: For this warranty to apply, ADP product must be properly installed, operated, and maintained in accordance with the installation, operation and maintenance instructions provided with each unit. Unauthorized alteration of ADP product may void this warranty.

Conditions of Warranty: Replacement parts furnished under this warranty will be warranted for the balance of the original warranty term of the unit (including any extended warranty) and will not serve to extend the original term. This warranty is void if the ADP product is removed from the original installation site. This warranty does not apply to damage caused by shipping, misuse, mishandling or damage caused by floods, winds, fires, lightning, or exposure to corrosive elements/environments (such as salt, chlorine, fluorine or other damaging chemicals).

Limitations of Warranty: The costs of miscellaneous material and labor charges for diagnostics, servicing or replacing parts are not covered. ADP shall have no liability for expenses incurred for repairs without prior, written authorization from ADP. No purchaser, distributor, dealer, representative, agent, person, firm or corporation has authority to alter, add to or modify this warranty, either orally or in writing.

No Other Warranties: ADP makes no warranty, express or implied, of fitness for any particular purpose, or of any other nature whatsoever, with respect to products manufactured or sold by ADP hereunder, except as specifically set forth above and on the face hereof. Any implied warranty of merchantability or fitness for a particular purpose on this product is limited in duration to the duration of this warranty. Some states and provinces do not allow limitations on how an implied warranty lasts, so the above limitation may not apply to you. It is expressly understood and agreed that ADP shall not be liable to buyer, or any customer of buyer, for direct or indirect, special, incidental, consequential or penal damages, or for any expenses incurred by reason of the use or misuse by buyer or third parties of said products. To the extent said products may be considered "consumer products", as defined in Sec. 101 of the Magnuson-Moss Warranty-Federal Trade Commission Improvement Act, ADP makes no warranty of any kind, express or implied, to "consumers," except as specifically set forth above on the face hereof. The foregoing is in lieu of all other warranties, express or implied, notwithstanding the provisions of the Uniform Commercial Code, the Magnuson-Moss Warranty-Federal Trade Commission Improvement Act, or any other statutory or common law, federal or state.

2175 West Park Place Boulevard
Stone Mountain, Georgia 30087

REV 090908



Advanced Distributor Products[®]

Solutions for Your needs

2175 West Park place blvd.
Stone Mountain, GA. 30087
www.adpnow.com
adp.feedback@adpnow.com