

INSTALLATION AND OPERATION MANUAL

EV450IN



NOTE: Disconnect Switch and 24V Transformer Standard

WARNING

RISK OF FIRE, ELECTRIC SHOCK, OR INJURY. OBSERVE ALL CODES AND THE FOLLOWING:

1. Before servicing or cleaning the unit, switch power off at disconnect switch or service panel and lock-out/tag-out to prevent power from being switched on accidentally. More than one disconnect switch may be required to de-energize the equipment for servicing.
2. This installation manual shows the suggested installation method. Additional measures may be required by local codes and standards.
3. Installation work and electrical wiring must be done by qualified professional(s) in accordance with all applicable codes, standards and licensing requirements.
4. Any structural alterations necessary for installation must comply with all applicable building, health, and safety code requirements.
5. This unit must be grounded.
6. Sufficient air is needed for proper combustion and exhausting of gases through the flue (chimney) of fuel burning equipment that might be installed in the area affected by this equipment. If this unit is exhausting air from a space in which chimney-vented fuel burning equipment is located, take steps to assure that combustion air supply is not affected. Follow the heating equipment manufacturer's requirements and the combustion air supply requirements of applicable codes and standards.
7. Use the unit only in the manner intended by the manufacturer. If you have questions, contact the manufacturer.
8. This unit is intended for general ventilating only. Do not use to exhaust hazardous or explosive materials and vapors. Do not connect this unit to range hoods, fume hoods or collection systems for toxics.
9. When cutting or drilling into wall or ceiling, do not damage electrical wiring and other hidden utilities.
10. This unit must be properly ducted to the outdoors.

CAUTION

To avoid motor bearing damage and noisy and/or unbalanced impellers, keep drywall spray, construction dust, etc., out of unit.



Placement of the EV450IN

The EV450IN is designed for installation indoors.

Select a location that is central to the inside duct runs, and close to both the exhaust duct (to the outside) and the fresh air duct (from the outside). The unit can be installed in any orientation but the contractor is responsible for safe installation of the unit.

For maximum air performance minimize the number of elbows, and do not place elbows within three feet of the EV450IN's discharges. For applications where duct noise is a critical issue, use noise attenuating techniques such as duct isolation, insulation, and proper duct design per SMACNA or ASHRAE standards.

Ducts to the Outside

The EV450IN requires four ducts:

Exhaust Air Duct (insulated duct from unit to outside);
Outside Air Duct (insulated duct from outside to unit);
Room Air Duct (from room to unit);
Fresh Air Duct (from unit to room).

Ducts from unit to the outside must be insulated with sealed vapor barrier on both inside and outside of the insulation or with closed-cell foam insulation. We recommend you use either:

8" X 12" insulated duct **OR**
10" I.D. flexible insulated duct

The **exhaust outlet and fresh air inlet on the outside** of the building should be at least **ten feet apart** to avoid cross-contamination. The exhaust outlet should not dump air into an enclosed space or any other structure. The inlets and outlets should be screened against insects and vermin and shielded from the weather to prevent the entry of rain or snow.

Using Flex Duct to connect EV450IN to outside

When connecting 10" flexible insulated duct to the Exhaust Air and Outside Air ports on the unit use the optional Duct Adapter Kit (45EVT10) (or fabricate equivalent). Duct need not be flexible, but must have continuous vapor barrier on both inner and outer face of insulation. Position the duct adapters over the openings. Install them with supplied self-drilling screws.

Keep insulated duct runs as short and direct as possible. Suspend or support duct per manufacturer's instructions.

⚠ WARNING

The fresh air inlet should be at least 10' away from chimneys, furnace and water heater exhausts, and other sources of carbon monoxide, humidity or other contamination. Do not locate the fresh air inlet where vehicles may be serviced or left idling. Never locate the fresh air inlet inside a structure.

CAUTION

Tape both inner and outer vapor barriers of insulated duct to collars on duct adapters and on wall caps. This is critical to prevent migration of moisture into insulation. Build-up of moisture can result in failure of the duct system and/or frost in the insulation. Make sure any tears in the inner and outer vapor barriers are sealed.

CAUTION

Do not vent exhaust duct up through roof. Condensate will form in cold weather and run back into unit. Instead, slope duct slightly downhill to a horizontal-discharge wall cap, which will allow any condensate to drain to the outside.

NOTE: To prevent the entry of rain through the outside air inlet duct, observe the following:

1. velocity at face of inlet hood should not exceed 500 feet per minute (fpm)
2. inlet duct must be at least 12" inside diameter
3. centerline length along duct from weather hood to unit inlet must be at least 48"
4. centerline of inlet hood must be at least 18" below the centerline of the unit inlet
5. outlet duct must pitch downward to the outside with a slope of at least ¼" to the foot

Mounting the EV450IN

The EV450IN has integral flanges for mounting to a wall (Figure 1) or hanging from a ceiling (Figure 2). An optional hanging bracket kit, 45EVHB, is available for hanging the unit from a ceiling with doors opening horizontally (Figure 3). The 45EVHB kit can also be used for floor mount legs (Figure 4). With all installations, adequate clearance for the filter access door latches must be provided.

The EV450IN unit includes a hardware kit that includes four rubber isolation mounts and eight washers. Figures 5 and 6 show how to install this mounting hardware for different installations. Please note that the threaded rod, bolts, nuts, or other fasteners are not included. If hanger bolts or threaded rod are used each must be capable of carrying the weight of the unit and must be no less than 3/8" diameter.

Figures 7 and 8 show the rubber door keepers. In order to remove doors these keepers must be removed.

CAUTION

The EV450IN weighs approximately 140 lbs. It is the installer's responsibility to make sure that the screws or bolts used for securing the units are properly selected for the loads and substrates involved. Secure the EV450IN so that it cannot fall or tip in the event of accident, structural failure or earthquake.

CAUTION

Do not stand on the unit. Do not stack or store items on the unit when installed.

CAUTION

Provide Adequate Service Access for Maintenance
The EV450IN will require regular filter and core inspections. Install the EV450IN where you can remove the doors for cleaning the core and replacing the filters, and where you can get at the wiring for installation and service.

Inside Ductwork System

Use optional 8" X12" to 10" round transitions (45EVT10) (or fabricate equivalent) to connect 10" duct to Room Air and Fresh Air Ports on unit. Position duct adapters over openings. Install with supplied self-drilling screws.

OR

Use optional 8" X 12" duct flange (45EVDF) to connect 8" X 12" duct to Room Air and Fresh Air Ports on unit. Position duct adapters over openings. Install with supplied screws.

Or fabricate equivalent, by forming a flange on the first duct section and screw it to the EV450IN. Make sure appropriate duct sealant or tape is used to provide an air tight seal.

NOTE: If the inside ducts run through un-conditioned spaces they must be insulated with a sealed vapor barrier on both inside and outside of insulation. In a heated space, uninsulated duct is acceptable, but insulated duct resists break out noise better. Duct sealing improves ventilation performance.

Most installations will not require complicated duct systems to provide good ventilation performance. If ventilating several spaces, evaluate whether the air in the spaces is regularly mixed by the heating/cooling system; if not, provide a room air pick-up and fresh air supply in each space. If air is regularly mixed by the heating/cooling system, one room air pick-up and one fresh air supply may be all that is needed.

Connecting to an existing air-circulation system

It is often convenient and effective to connect the Fresh Air duct from the EV450IN to a return duct of an existing heating/cooling system. This way, whenever the heating/cooling system is running, fresh air from the EV450IN is distributed throughout the area served by the heating/cooling system.

Connect the Fresh Air duct to a branch return duct at some distance from the heating/cooling system's air handler. This minimizes the amount of air that the air handler can pull through the EV450IN when outside air ventilation is not desired.

If the EV450IN is running when the main air handler is not, fresh air will flow into the space through the branch's return grille. Choose the return branch for your connection accordingly (see next paragraph).

Ducting Fresh Air Directly into Space

In cold or hot weather, the fresh air will be somewhat cooler or warmer than the room air (though always much closer to room temperature than the outside air!). Avoid complaints by locating the Fresh Air supplies where they will not blow directly on occupants.

See drawings below for examples of some common installation approaches:

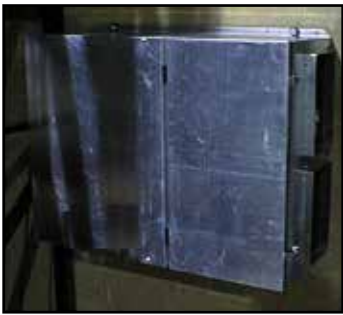
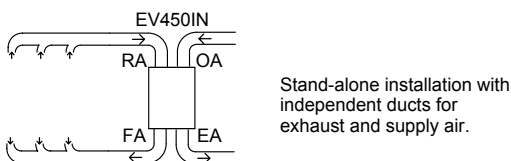
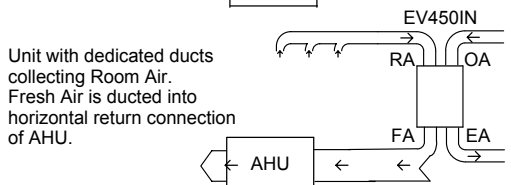
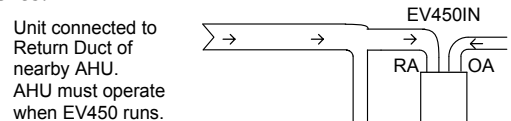

Figure 1. Unit mounted to wall using integral mounting flanges.



Figure 5. Hardware kit included with unit and installed on integral mounting flange for wall installation. Note: threaded rod, bolts, nuts, and other fasteners are not included in kit.

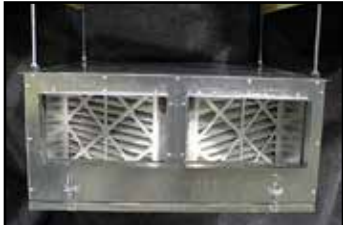

Figure 2. Unit hung from ceiling using integral mounting flanges.



Figure 6. Hardware kit shown installed on optional hanging bracket for ceiling installation.



Figure 3. Unit hung from ceiling using optional hanging bracket kit, 45EVHB. To install hanging bracket, identify the corners of unit you wish to hang it from. Remove existing screws from unit pan. Attach hanging bracket to unit using screws provided with the hanging bracket.



Figure 7. Rubber Door Keeper installed on Blower Access (large) Door.

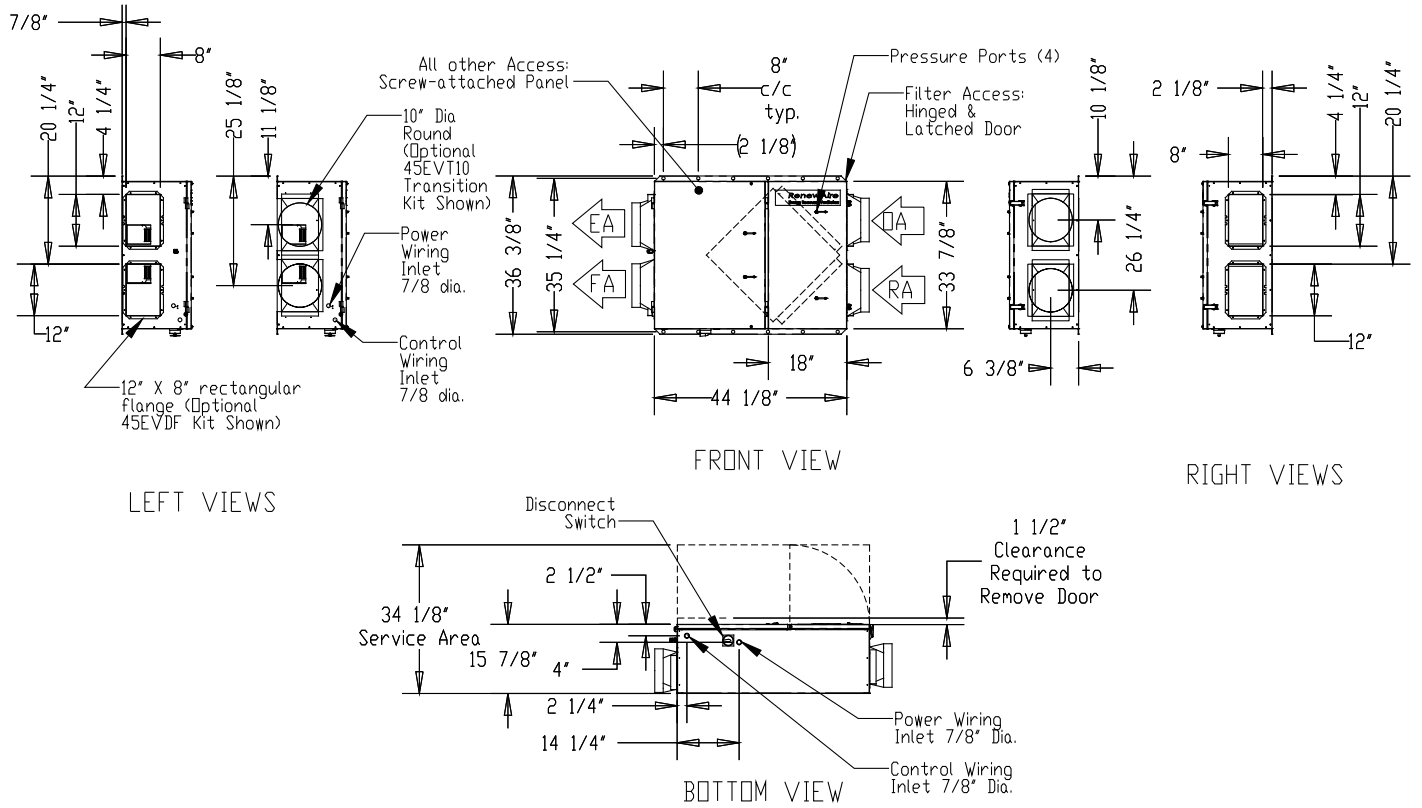

Figure 4. Unit secured to floor using optional hanging bracket kit, 45EVHB.

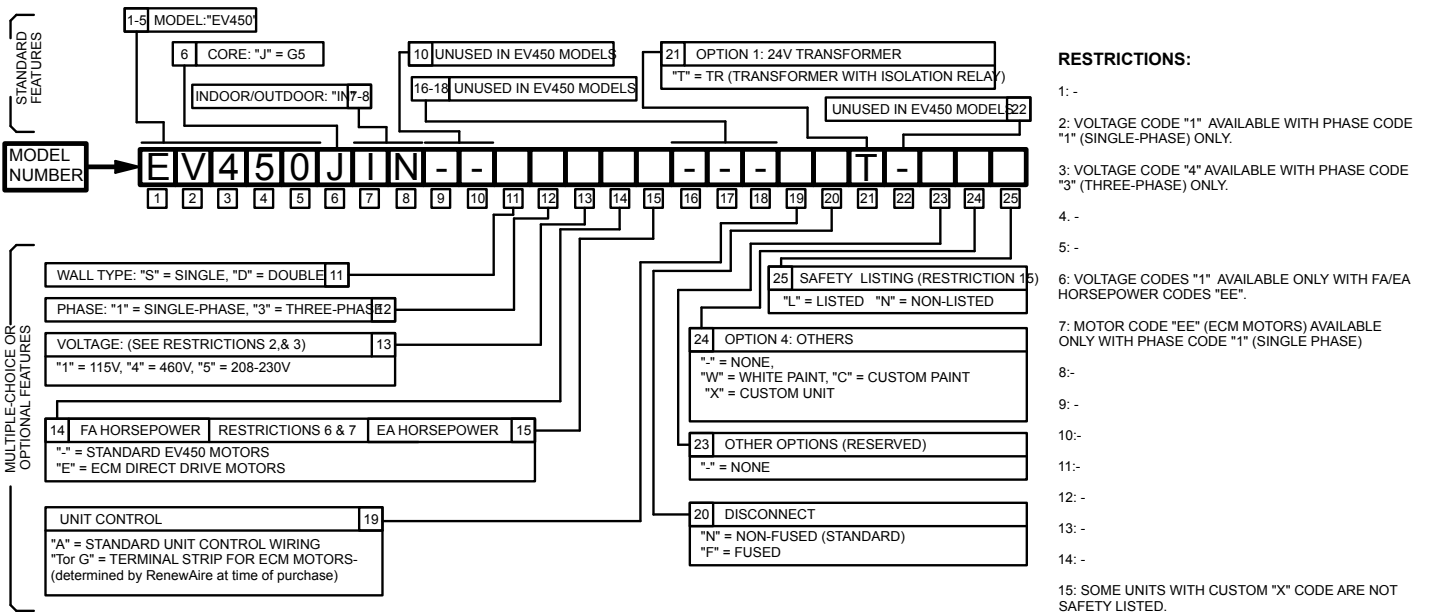

Figure 8. Rubber Door Keeper installed on Filter Access (small) Door.

EV450IN Dimensions



EV450IN Product Configuration Chart



Sound Attenuation

General Practices

Take these simple steps to attenuate noise from the unit.

Outside the building:

Exhaust velocity noise is the primary cause of unit-related noise outside the building. Size the exhaust duct and grille for less than 1000 fpm air velocity. When practical, orient the exhaust air hood to point away from houses or public areas.

Ducts:

Make sure the ductwork at the unit outlets is stiff enough to resist the flexure and resulting booming associated with system start-up and shut-off, as well as the turbulent flow conditions at the blower outlets.

In general, provide smooth transitions from the ERV's outlets to the duct. The ducts connecting to the outlets should be straight for a sufficient distance, with gradual transitions to the final duct size.

These guidelines are consistent with SMACNA recommended duct layout practices for efficient and quiet air movement. Follow SMACNA guidelines.

Radiated Noise

The EV450IN is insulated with high-density fiberglass. This provides significant attenuation of radiated sound.

The outlet ducts can be significant sources of radiated sound as well. The FA and EA ducts (outlet ducts) should be insulated for sound control. This insulation should start at the unit. At a minimum the first ten feet of duct should be insulated. All parts of the FA and EA ducts located in the mechanical space should be insulated for sound control, both to minimize sound radiation out of these ducts and also to control sound radiation into the ducts.

Aerodynamic (Velocity) Noise

When sound attenuation is a design concern, the primary consideration is velocity noise at the unit's Fresh Air blower outlet. The average velocity at the blower outlets is 1100 FPM when the unit is operating at 600 CFM.

Electrical Specifications

NOTE: If your unit is equipped with ECM Motors, please refer to "ECM Motor Manual Supplement for RenewAire Light Commercial Units" for more detail.

Use conduit, strain reliefs, etc. as required by code to secure the field wiring.

Electrical Options are identified on the Unit Label located near electrical box on the outside of the unit. Find the complete Unit Model Number in the lower left corner of the Unit Label. Use the configuration chart to the left to determine motor power and voltage installed in your EV450IN.

⚠ WARNING

Danger of Electrical Shock when servicing an installed unit.

ALWAYS DISCONNECT POWER SOURCE BEFORE SERVICING! More than one disconnect switch may be required.

Proper Wiring Size Selection and Wiring Installation are the Responsibility of the Electrical Contractor.

CAUTION

Before bringing power to the unit check unit nameplate to confirm it matches the voltage and phase of the power you are supplying.

Remember that your field connections need to be accessible for inspection.

Follow these steps:

1. Confirm the voltage of the power supply matches the unit.
2. Remove both unit access panels, i.e., the larger motor door and small filter door.
3. Remove electrical box cover by removing two or three screws. Connect the units power field wiring to the terminals of the disconnect switch.
4. Connect service ground to ground wire pigtail.
5. Connect the control system to the pigtails in the control voltage compartment of the units electrical box. Make sure you are connecting the correct voltage, 24VAC, to the control pigtails. See Control Wiring Schematics.

CAUTION

You must make sure to provide the correct voltage and phase power supply. Installing the incorrect voltage and phase will destroy the motor and possibly lead to injury!

Performance

Airflow CFM	ESP in. H2O	Watts 1P	Watts 277V	Watts 3P	Temp EFF%	Total EFF% Winter/Summer*
225	1.25	335	300	181	81	76/66
338	1.00	420	370	278	77	71/61
380	0.90	470	405	340	75	69/59
450	0.65	550	470	430	73	66/56
540	0.25	640	560	540	70	62/52
575	0.00	690	600	610	69	61/51
600	-0.25	735	635	664	68	60/50

*ERV component performance at AHRI 1060 standard conditions.

CAUTION

Make sure clean filters are installed before balancing airflow. Dirty or clogged filters reduce airflow through the unit.

Airflow Performance

Use the pressure taps in the core and filter doors to determine the airflow. Figure 1 translates the pressure drop across the energy recovery core to the actual airflow volume.

Equipment Required

- Magnehelic gauge or other device capable of measuring 0-1.5 in. water of differential pressure.
- 2 pieces of flexible tubing, 1/8" ID, 1/16" wall works best.
NOTE: Be sure to remove cap from pressure port before inserting tubing. Insure tubing is well seated in pressure ports.
NOTE: The tubing should extend in the pressure port approximately 1 inch.

Cross Core Static Pressure Measurement Instructions

- The individual differential static pressures (DP) are measured using the installed pressure ports located in the front of the units core access doors.
NOTE: These ports are carefully located on the unit to give the most accurate airflow measurement.
NOTE: Do not relocate pressure ports.
- To read SCFM of Fresh Air (FA) install the "high" pressure side (+) of your measuring device to the Outside Air (OA) port and the "low" pressure side (-) to the Fresh Air (FA) port.
- To read SCFM of Room Air (RA) install the "high" pressure side (+) of your measuring device to the Room Air (RA) port and the "low" pressure side (-) to the Exhaust Air (EA) port.
- Use the reading displayed on your measurement device to cross reference the CFM output using the conversion chart.
NOTE: Be sure to replace cap into pressure port when airflow measuring is completed.
- Adjust airflow by changing the potentiometer setting for the measured airstream.
- **NOTE:** For best performance the airflow rate for both the Fresh Air and the Exhaust Air should be roughly equal ("balanced"). In some facilities a slight positive or negative pressure in the building is desired. RenewAire energy recovery ventilators can generally operate with a flow imbalance of up to 20% without significant loss in energy recovery efficiency.

AIRFLOW PREDICTED BY PRESSURE DROP ACROSS CORE (SCFM)

DP ("H2O)	EV450IN	
	FA	RA
0.20	200	200
0.25	225	225
0.30	245	245
0.35	265	265
0.40	285	285
0.45	305	305
0.50	330	330
0.55	350	350
0.60	370	370
0.65	390	390
0.70	410	410
0.75	430	430
0.80	455	455
0.85	475	475
0.90	495	495
0.95	--	--
1.00	--	--
1.05	--	--
1.10	--	--

Figure 1.
CHART: AIRFLOW vs. PRESSURE DROPS

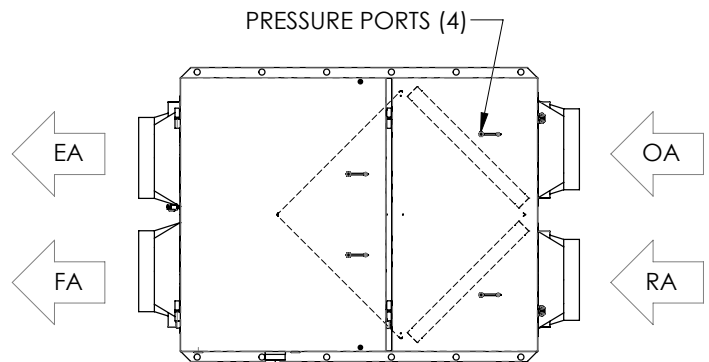

Wiring Schematics

EV450 P1 WIRING SCHEMATIC

See Installation Manual for additional Control Wiring Options.

FIELD-WIRED SINGLE PHASE POWER SUPPLY
VOLTAGE AS SHOWN ON UNIT NAMEPLATE

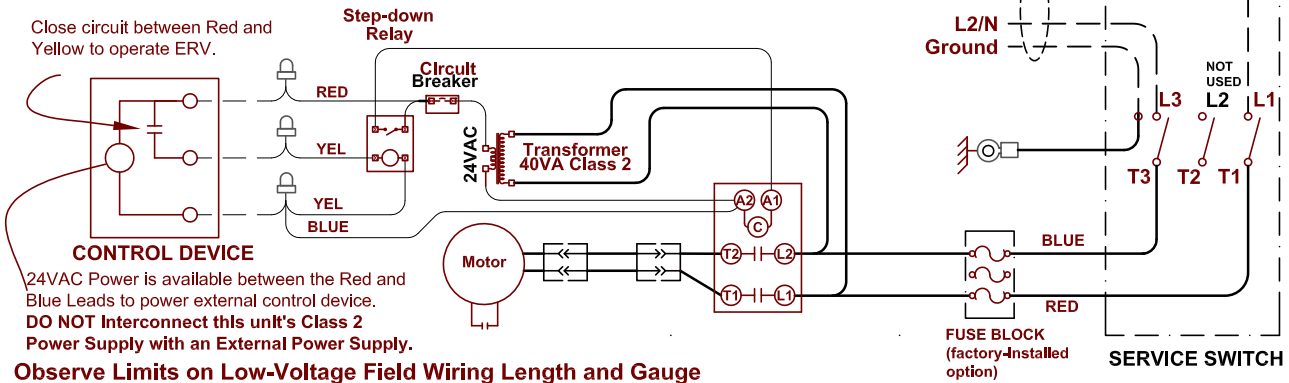

EV450 P3 WIRING SCHEMATIC

See Installation Manual for additional Control Wiring Options.

FIELD-WIRED THREE-PHASE POWER SUPPLY
VOLTAGE AS SHOWN ON UNIT NAMEPLATE

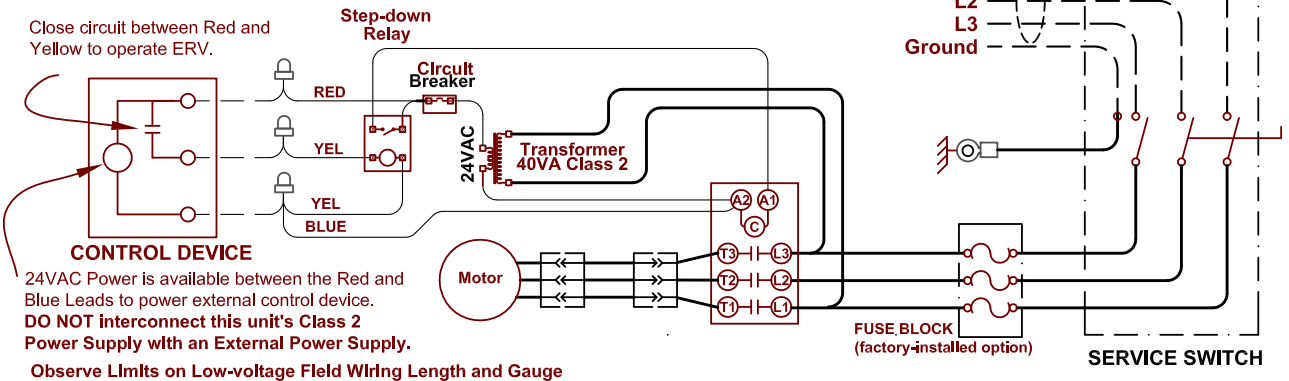

EV450IN Replacement Parts

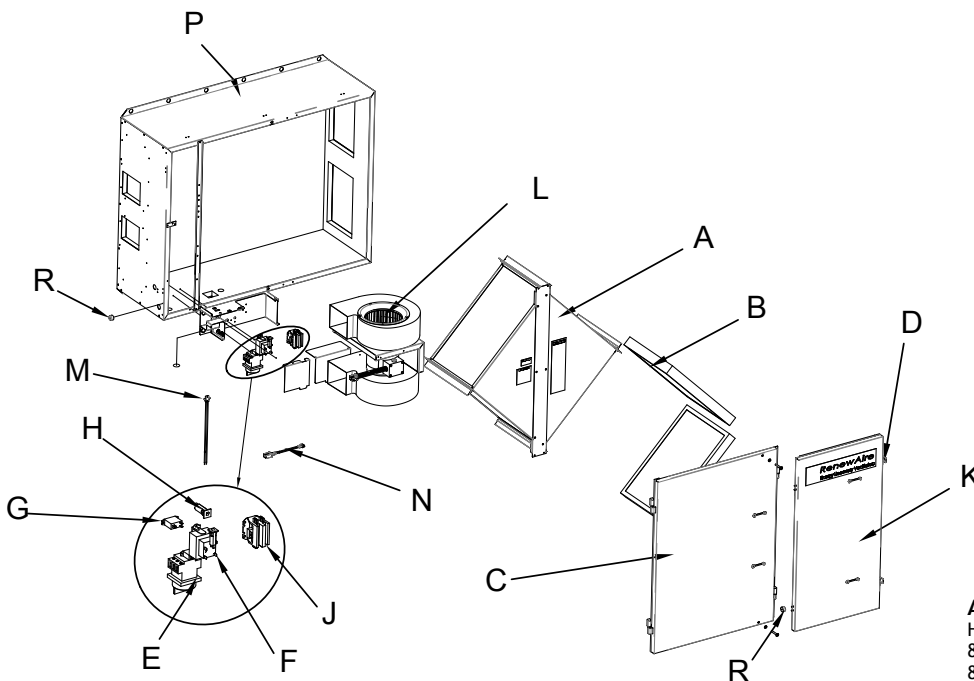

A	CORE
B	FILTERS
C	BLOWER DOOR
D	DRAW LATCH
E	DISCONNECT SWITCH
F	TRANSFORMER
G	ISOLATION RELAY
H	CIRCUIT BREAKER
J	CONTACTOR
K	FILTER ACCESS DOOR
L	MOTOR BLOWER ASSEMBLY
M	WIRE HARNESS
N	VOLTAGE ADAPTER
P	INSULATED CASE
R	DOOR BUMPER

Accessories

Hanging Bracket/Floor Mount Legs (2 pieces) 45EVHB
8" X 12" to 10" Round Transition (2 pieces) 45EVT10
8" x 12" Duct Flange (2 pieces) 45EVDf

24VAC Power Supply Provided with this ERV Unit

This ERV is provided with a Class II 24VAC power supply system that operates the unit's contactor(s) for EV450 and HE1X. The ERV's 24VAC Power Supply can also be used to power the externally-installed controls system: up to 8VA of power is available.

The unit's power supply system includes isolation relay(s) so you can use external controls whose contact ratings are as low as 50mA (1.2VA). Also, it is possible to operate the isolation relays with 24VAC power from an external source (with proper wiring connections).

A built-in circuit-breaker prevents damage to the transformer and other low-voltage components in the event of a short-circuit or overload. In extreme cases, the transformer itself is designed to fail safely.

CAUTION

1. Connect only to components intended for use with 24VAC power.
2. Do not undersize the low-voltage wires connected to this device. Observe the wire length and gauge limits indicated in this manual.
3. Do not overload this unit's 24VAC power supply system. Confirm that the power requirements of devices you connect to this power supply system do not exceed 8VA in total.
4. If an external source of 24VAC power is used to control the unit, consult the wiring schematics and connect the external power only to the specified terminals in order to avoid damaging the unit or external controls. Connect only CLASS II power to the control terminals of this unit.
5. Unit is not equipped to receive analog signals (such as 1-10vdc or 4-20mA).
6. Unit is not equipped to communicate directly with Building Management Systems (such as BACNET, LONWORKS, etc.). However, the unit can be controlled by powered or non-powered contacts operated by any kind of control system.

Specifications

- Nominal Output Voltage under load: 24VAC
- Typical Output Voltage at no load: 29-31V
- Minimum contact rating for connected control device: (50mA (1.2VA) 3A)
- Circuit Breaker Trip Point: 3A

How to Reset the 24 VAC Circuit Breaker

If the transformer is subjected to an excessive load or a short circuit, the circuit breaker will trip to prevent the failure of the transformer. When it trips the circuit breaker's button pops up. Shut off the primary-side power to the unit, and remove the excessive load or the short. The circuit breaker can be reset about fifteen seconds after it trips by pressing in the button.

NOTE: INSTALLING CONTRACTOR:

If primary-side voltage is 230VAC, move black primary-side lead from transformer's "208V" terminal to the transformer's terminal marked "240V" ("230V" in some units).

Do not move the black primary-side lead that is connected to the transformer's "COM" terminal.

Limits of Power Output

If limits on wire gauge and length are observed, you may connect control devices that draw up to 8VA to the blue and red wires. More than one device can be connected as long as total steady-state load does not exceed 8VA.

OBSERVE THESE LIMITS TO WIRE LENGTH AND GAUGE, in order to ensure reliable operation of the control system.

Wire Gauge	#22	#20	#18	#16	#14	#12
Circuit Length	100'	150'	250'	400'	700'	1000'

"Circuit Length" is distance from ERV to Control Device.

Control Wiring Schematics

NOTE: The simplified schematics below show only the relevant portions of the low-voltage control circuit in the ERV unit and representational external control approaches. See the complete unit schematics elsewhere in this manual.

CAUTION

Be careful if the external control system provides 24VAC power at its control output: make sure blue and red leads are separately capped and not connected to any other wires.

- A. **Single 2-wire Control:** Use schematic below if the control requires no power to operate and acts like a simple on/off switch. **The control must not supply any power to the ERV unit.** Install jumper (provided) between terminals 2 & 3. Connect the control's contacts to terminals 1 & 4 to operate the ERV's isolation Relay.

Control on separate Power Supply, no power present at Control Output: Wire as shown for the Single 2-wire control.

CAUTION

Make sure the control provides no voltage or current at its output terminals.

A SWITCH OR NON-POWERED CONTROL USING UNIT'S 24VAC POWER SUPPLY

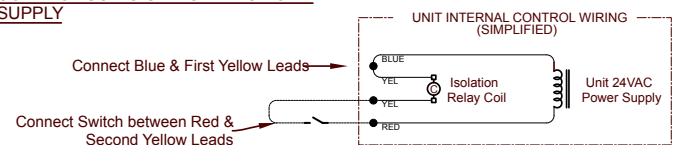

- B. **Control Sending 24VAC "On" Signal (from an external power source) to ERV:** Make sure jumper is NOT installed between Terminals 2 & 3. Now you safely can apply 24VAC to the Terminals 3 & 4 to operate the ERV's isolation relay.

CAUTION

Supply only 24VAC (not VDC) from a Class II Power Source.

24VAC FROM AN EXTERNAL SOURCE

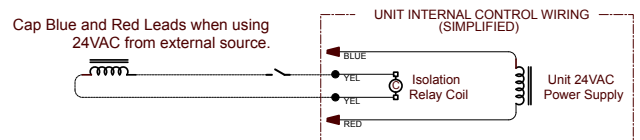

- C. **Control operating on Unit's 24VAC Power Supply:** 24VAC power is available at the Terminals 1 & 2. **CAUTION:** external control system should not draw more than 8VA. Install jumper (provided) between terminals 2 & 3. Connect the switched output of the Control to Terminal 4 to operate the ERV's isolation relay.

AN EXTERNAL CONTROL DEVICE USING UNIT'S 24VAC POWER SUPPLY

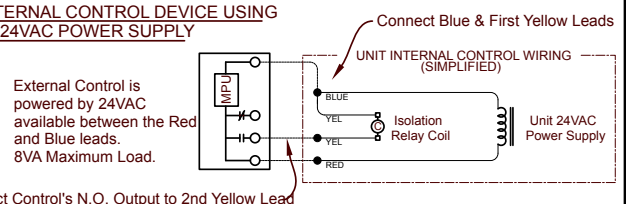

THIS PAGE LEFT INTENTIONALLY BLANK.

THIS PAGE LEFT INTENTIONALLY BLANK.

THIS PAGE LEFT INTENTIONALLY BLANK.

Maintenance

SUMMARY MAINTENANCE REQUIREMENTS

Change Filters
Inspect Blower
General Cleaning and Inspection
Clean Energy Exchange Cores
Lubrication

CHANGING THE FILTERS

Inspect and/or replace filters every two or three months when the unit is in regular use, or as needed.

- Turn off unit completely! Lock-out and tag-out the unit disconnect switch.
- Open the Door. The door is secured with turn-type latches or draw latches, plus one Phillips-head securing screw. Keep the securing screw. NOTE: Always replace securing screw when reinstalling door.
- Remove and dispose of all (2) filters. Replace all (2) filters. NOTE: See chart for information on the initial resistance of the filters originally supplied with this unit. If replacement filters have higher resistance, the airflow of the system will be lower.
- Close door; reinstall securing screw.

Blower Inspection

Inspect Blowers every time you change the filters.

- Confirm bearings are still secure to blower shaft. It should not be possible to move the blower shaft back and forth along its length.
- Confirm blower wheel is not rubbing against the blower inlet or housing.

GENERAL CLEANING AND INSPECTION

Perform general cleaning and inspection when changing filters.

- Remove dust from blower wheels periodically.
- Remove paper, leaves, etc. from inlet and outlet screens.
- Inspect for insect nests.

TO CLEAN THE ENERGY EXCHANGE CORE

Clean the core annually.

- Remove the filters.
- Vacuum the exposed faces of the energy exchange core with a soft brush.
- Vacuum out dust from the rest of the unit case.
- Install new filters.

LUBRICATION

If the motors used in this ERV are equipped with grease fittings, motors must be lubricated as part of routine maintenance. Use Exxon Polyrex or equivalent at 2500 operating hour intervals.

⚠WARNING

Danger of injury from un-guarded blower in unit. Disconnect power to unit before opening door.

Danger of injury if unit starts unexpectedly. Switch power off at service disconnect. Lock-out/tag-out the disconnect.

Initial Resistance of Filters supplied with this unit:

INITIAL PRESSURE DROP 14" x 20" MERV 8 FILTERS
RENEWAIRE SERVICE PART NUMBER 990091

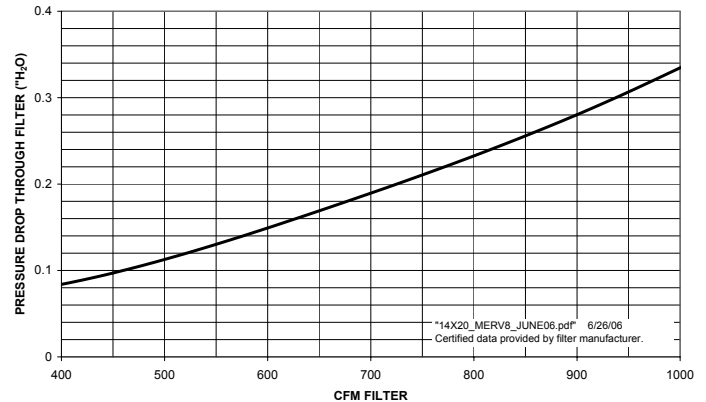

Filter Specifications:

(2) 14" x 20" x 2" (nominal) pleated filters
Actual size: 13.5" x 19.5" x 1.75"
Unit shipped with MERV-8 Filters
Minimum recommended effectiveness: MERV-6

CAUTION

Filters must be used or the energy exchange core will become blocked by dust and the unit will not do its job. In extreme cases components may be damaged.

CAUTION

DO NOT WASH THE ENERGY EXCHANGE CORE.
Keep it away from water or fire to avoid damaging it. Always handle the core carefully.

⚠WARNING

RISK OF INJURY OR DAMAGE.

Motor may have a manual reset thermal protector. Disconnect power before servicing or resetting motor thermal protector. Use caution, motor may be hot. Allow the motor to cool before resetting the thermal protector.

If the motor thermal protector tripped, correct the issue that caused the motor to overheat (e.g. over motor rated amperage or locked rotor).

If the motor has a manual reset thermal protector, the red thermal protector reset button is located on the motor body, on or near the lead end of the motor. If the button does not reset, the motor may still be too hot. Allow the motor to fully cool to reset the thermal protector, you should feel or hear a click when the thermal protector resets while pushing the reset button.