

INSTALLATION AND OPERATION MANUAL

HE4XINV



NOTE: Disconnect Switch and 24V Transformer Standard

In 2012, these ERVs may be ordered with new factory-installed features including Isolation Dampers and Variable Frequency Drives. Consult the supplemental Installation and Operation Manual(s) for these features if supplied.

⚠ WARNING

RISK OF FIRE, ELECTRIC SHOCK, OR INJURY. OBSERVE ALL CODES AND THE FOLLOWING:

1. Before servicing or cleaning the unit, switch power off at disconnect switch or service panel and lock-out/tag-out to prevent power from being switched on accidentally. More than one disconnect switch may be required to de-energize the equipment for servicing.
2. This installation manual shows the suggested installation method. Additional measures may be required by local codes and standards.
3. Installation work and electrical wiring must be done by qualified professional(s) in accordance with all applicable codes, standards and licensing requirements.
4. Any structural alterations necessary for installation must comply with all applicable building, health, and safety code requirements.
5. This unit must be grounded.
6. Sufficient air is needed for proper combustion and exhausting of gases through the flue (chimney) of fuel burning equipment that might be installed in the area affected by this equipment. If this unit is exhausting air from a space in which chimney-vented fuel burning equipment is located, take steps to assure that combustion air supply is not affected. Follow the heating equipment manufacturer's requirements and the combustion air supply requirements of applicable codes and standards.
7. Use the unit only in the manner intended by the manufacturer. If you have questions, contact the manufacturer.
8. This unit is intended for general ventilating only. Do not use to exhaust hazardous or explosive materials and vapors. Do not connect this unit to range hoods, fume hoods or collection systems for toxics.
9. When cutting or drilling into wall or ceiling, do not damage electrical wiring and other hidden utilities.
10. If installed indoors this unit must be properly ducted to the outdoors.

CAUTION

To avoid motor bearing damage and noisy and/or unbalanced impellers, keep drywall spray, construction dust, etc., out of unit.

CAUTION

Do not remove or disable the wiring interconnection between the Overload Relays and the Contactors. Without this interconnection the motor(s) will not be protected against overload.



Placement of the HE4XINV

The HE4XINV is designed for installation in a sheltered location, out of the weather.

The preferred mounting location is sitting on a concrete floor. Unit base may be bolted to floor. The concrete will isolate any blower vibration.

Select a location that is central to the inside duct runs, and close to both the exhaust duct (to the outside) and the fresh air duct (from the outside).

The exhaust outlet and outside air inlet on the outside of the building should be at least ten feet apart to avoid cross-contamination. The fresh air inlet should be at least 10' away from any exhaust, such as dryer vents, chimneys, furnace and water heater exhausts, or other sources of contamination or carbon monoxide. Never locate the outside air inlet inside a structure.

The exhaust outlet should not dump air into an enclosed space or any other structure. The inlets and outlets should be screened against insects and vermin and shielded from the weather to prevent the entry of rain or snow.

Install the ERV where you can open the door for cleaning the core and filter, and where you can get at the wiring for installation and service.

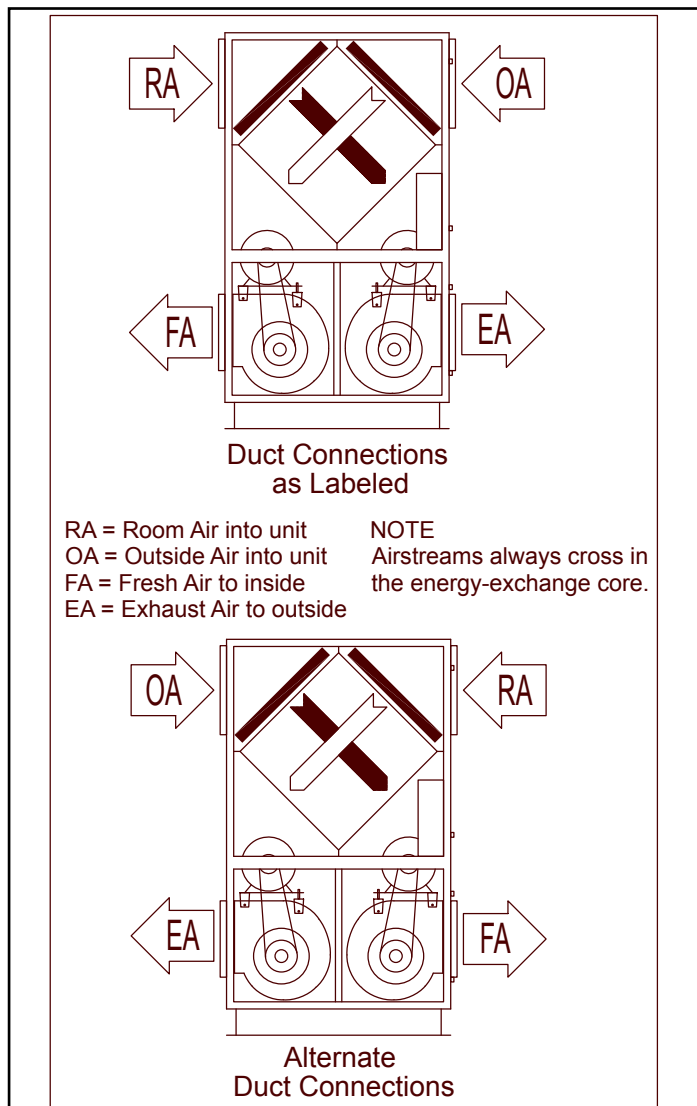

Exhaust & Fresh Air Ducts Between HE4XINV & Outside

Insulation

Ducts connecting the HE4XINV to the outside must be insulated, with sealed vapor barrier on both inside and outside of the insulation.

The exhaust outlet and fresh air inlet on the outside of the building should be at least ten feet apart to avoid cross-contamination.

⚠ WARNING

Danger of carbon monoxide poisoning!

Outside air intake should be at least 10' away from sources of carbon monoxide or other toxic gasses; chimneys, furnace and water heater exhausts, or fume hood outlets.

Do not locate outside air intake where vehicles may be serviced or left idling.

Never locate the outside air inlet inside a structure.

Outside Wall Caps

Wall caps should be designed to exclude animals and rain. Wall caps should be sized for minimum pressure loss. To keep rain from being drawn in, the outside air intake should be large enough to keep inlet velocity below 500 feet per minute, (or as dictated by local practice).

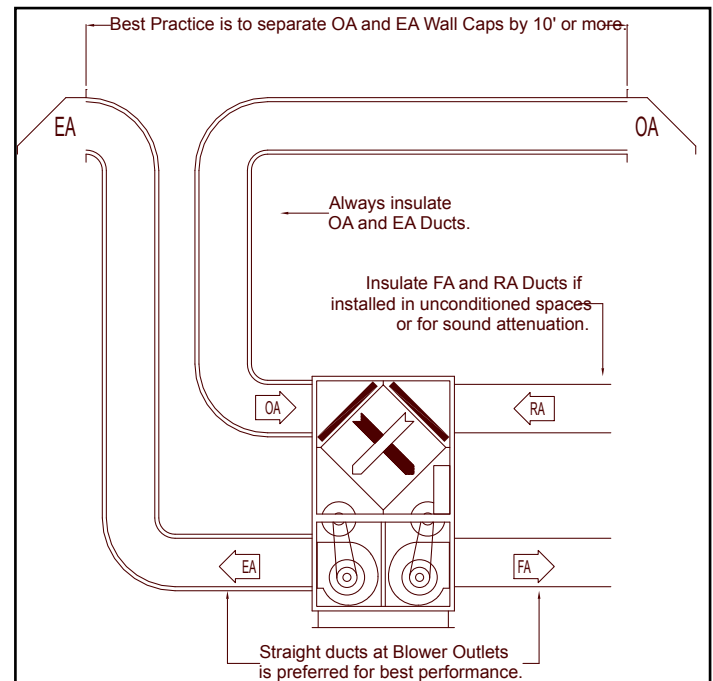

⚠ WARNING

DO NOT PLACE ANY PICK-UPS IN GARAGES, LOADING AREAS OR IN FUME HOODS!

Make the Ducts from the Stale Air Pick-ups to the HE4XINV as simple and direct as possible.

Inside Ductwork System

Follow Engineer's Ductwork Design

Ductwork should be designed by an engineer to allow the unit to provide the required airflow.

Design Tips

Air Flow Rates

Design the system to provide the lowest air exchange rate that will accomplish the ventilation goals. At lower air flow rates, energy recovery effectiveness improves. See Product Data Sheet.

Duct Transitions

Ducts should enter and exit the unit through smooth, gradual transitions.

Duct Insulation:

If the inside ducts run through un-conditioned spaces, they must be insulated, with a sealed vapor barrier on both inside and outside of insulation.

Picking up Stale Air in the Building

Locate the stale air pick-ups high in rooms where moisture, odor, or other contaminants are generated.

If some duct runs are much shorter than the others, install dampers so you can balance flows. Most rooms require only one stale air pick-up.

Duct Fresh Air from the HE4XINV into the heated space

Fresh Air from the HE4XINV often can be ducted into an existing HVAC air distribution system.

Sometimes, however, it is more practical to install a separate distribution system for the Fresh Air.

The Fresh Air supplied by the HE4XINV will be somewhat cooler or warmer than room air in very cold or hot weather. Consider this when deciding how to distribute the Fresh Air.

Connection of Fresh Air from HE4XINV to ducted heating & cooling system:

Avoid a situation in which operation of the main air-handling blower unbalances flow through the HE4XINV. (See Balance the Air Flows, below). This is a particular concern if the HE4XINV is to be operated on a different schedule from the main air-handler. Minimize the effect of the air-handler on the HE4XINV by connecting Fresh Air from unit at a point well upstream from the air handler.

Balance the Air Flows

The air flow rate for both the Fresh Air and the Exhaust Air should be roughly equal (or "balanced") for best performance of the HE4XINV. If the HE4XINV is connected to an existing air-handling system it may be necessary to check for balance with and without the main air-handling blower in operation.

In some facilities a slight positive or negative pressure in the building is desired. RenewAire heat recovery ventilators can generally operate with a flow imbalance of up to 20% without appreciable loss in heat recovery efficiency. However, very low exhaust air flow rates may result in frosting of the core during extremely cold weather.

Sound Attenuation

General Practices

Take these simple steps to attenuate noise from the unit.

Outside the building:

Exhaust velocity noise is the primary cause of unit-related noise outside the building. Size the exhaust duct and grille for less than 1000 fpm air velocity. When practical, orient the exhaust air hood to point away from houses or public areas.

Ducts:

Make sure the ductwork at the unit outlets is stiff enough to resist the flexure and resulting booming associated with system start-up and shut-off, as well as the turbulent flow conditions at the blower outlets.

In general, provide smooth transitions from the ERV's outlets to the duct. The ducts connecting to the outlets should be straight for a sufficient distance, with gradual transitions to the final duct size.

These guidelines are consistent with SMACNA recommended duct layout practices for efficient and quiet air movement. Follow SMACNA guidelines.

Radiated Noise

The HE4XINV is insulated with high-density fiberglass. This provides significant attenuation of radiated sound.

The outlet ducts can be significant sources of radiated sound as well. The FA and EA ducts (outlet ducts) should be insulated for sound control. This insulation should start at the unit. At a minimum the first ten feet of duct should be insulated. All parts of the FA and EA ducts located in the mechanical space should be insulated for sound control, both to minimize sound radiation out of these ducts and also to control sound radiation into the ducts.

Aerodynamic (Velocity) Noise

When sound attenuation is a design concern, the primary consideration is velocity noise at the unit's Fresh Air blower outlet. The average velocity at the blower outlets is 1586 FPM when the unit is operating at 4230 CFM.

CAUTION

The HE4XINV weighs approximately 815 lbs. It is the installer's responsibility to make sure that the screws or bolts used for securing the units are properly selected for the loads and substrates involved. Secure the HE4XINV so that it cannot fall or tip in the event of accident, structural failure or earthquake.

HE4XINV Dimensions

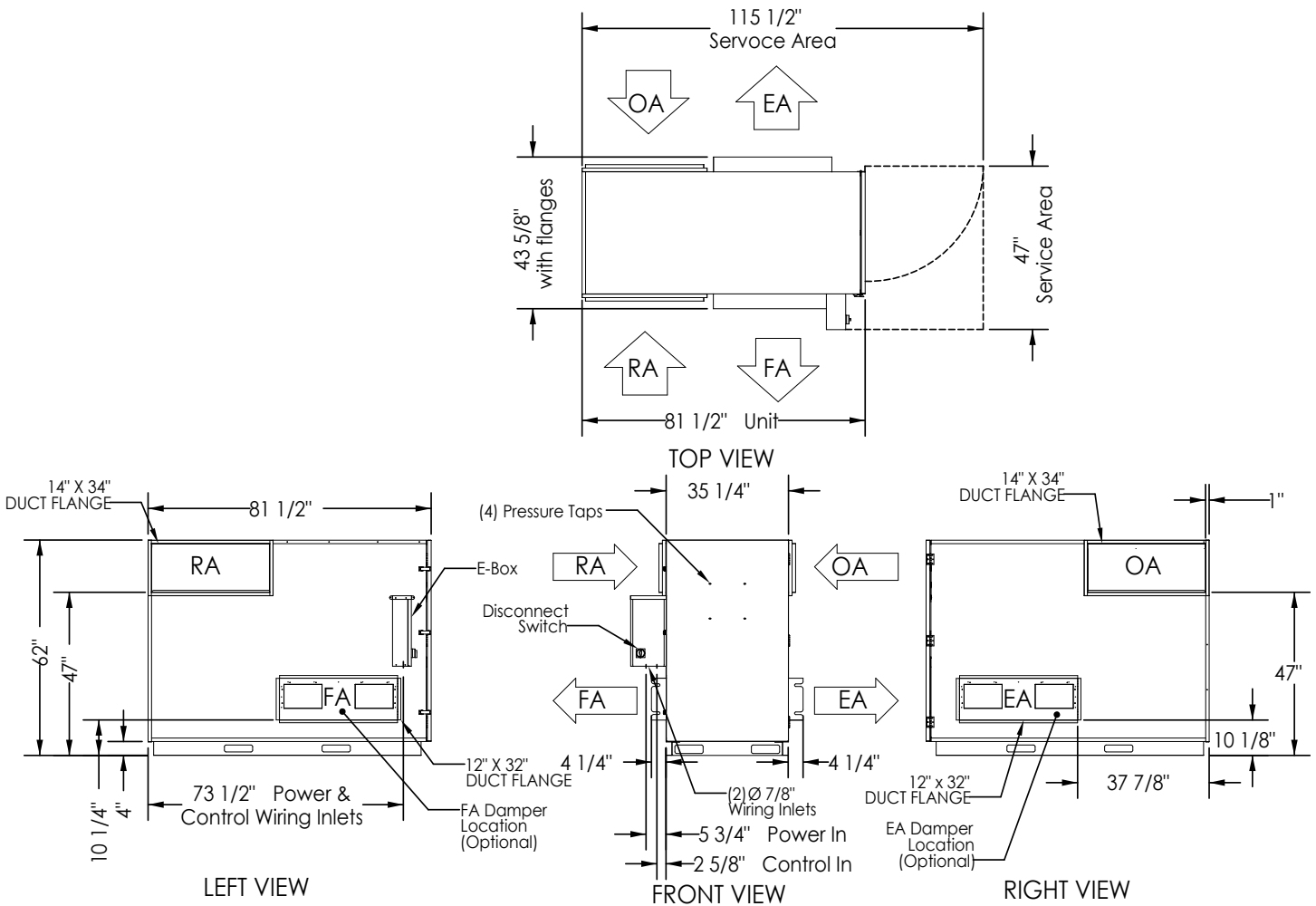

HE4XINV Product Configuration Chart

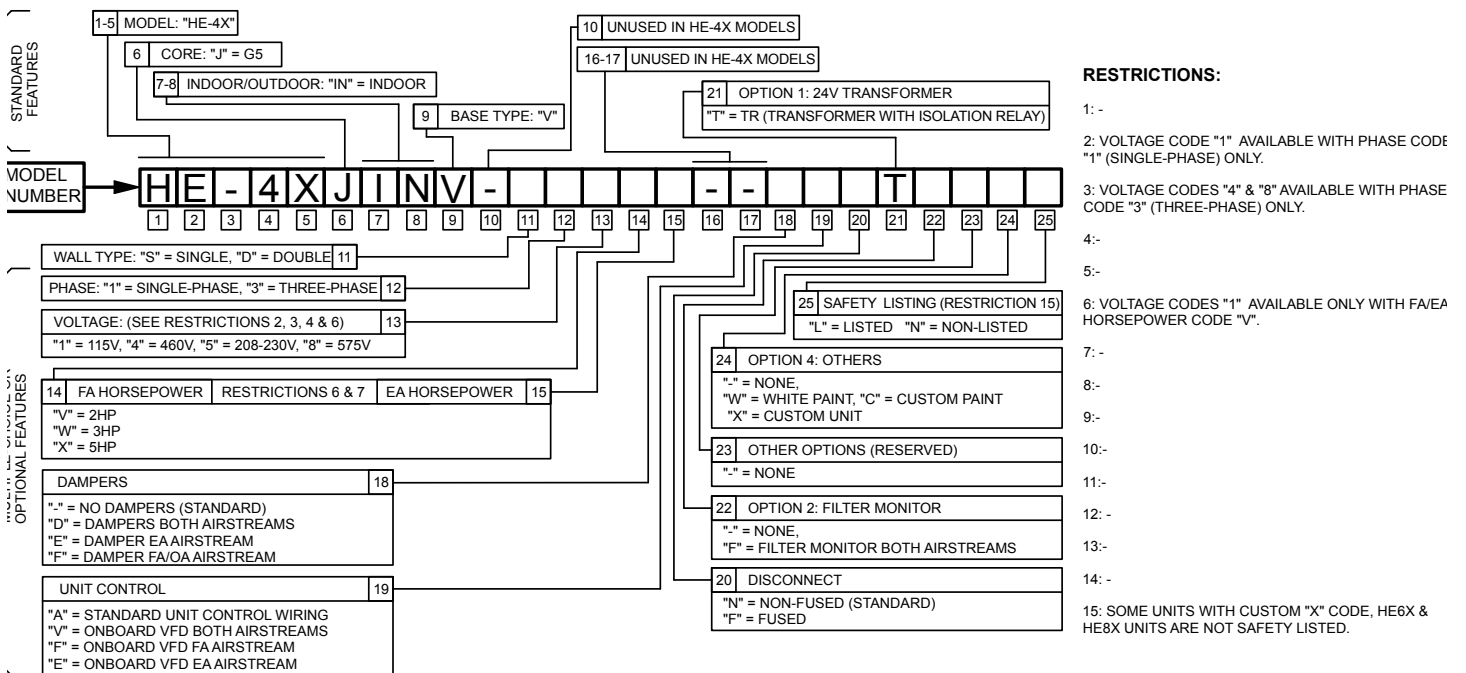

Operation

Principal of Operation

The HE4XINV has one basic purpose: to exhaust air from a structure and bring in fresh air from outside, while transferring heating or cooling energy from the exhaust air to the fresh air.

The HE4XINV is a very simple device, and will accomplish this purpose as long as the blowers for both airstreams are able to move air through the energy-exchange core.

Checking that Unit is Operating

Airflow

Airflow should be occurring in both airstreams. Sometimes the easiest place to confirm that air is moving is at the external wall caps.

If exact airflow is critical, it may be desirable to permanently install flow measuring stations and manometers. These also can be used to determine when filters should be cleaned or changed.

Use Static Taps in Doors to Measure Airflow Rates

See "Cross-Core Static Drop" in MEASURING AIRFLOW table. These may be used to directly measure airflow in the unit.

Energy Exchange

Precise determination of installed sensible energy exchange effectiveness requires careful measurement of temperatures and airflows in all four airstreams, and in practice is somewhat difficult.

It is possible to confirm that energy is being exchanged simply by feeling the ducts. If the Fresh Air duct from the unit into the room is closer to room temperature than to the outside temperature, energy is being recovered.

Operating Controls

A wide variety of control schemes may be selected by the engineer, installer, or owner to meet the ventilation needs of the facility. These may include timer clocks, occupancy sensors, dehumidistats (for cool-weather operation), carbon dioxide sensors, and others. DDC systems may also control the unit with external control by other. Most control schemes will operate the unit only when needed.

Continuous Operation

Continuous operation is acceptable in virtually all conditions. Unit will not be damaged by continuous operation as long as air flow occurs. Blower motors may overheat if filters become completely blocked due to lack of maintenance. Motors are thermally protected. With continuous operation, some external frosting may occur in very cold weather (see below).

Operation in Extreme Cold Weather

Unit is capable of operating at outside temperatures down to -10°F, with indoor humidities below 40%, without any internal frosting. Unit can operate at more severe conditions occasionally with little or no impact on its performance. At lower humidities, it can operate at lower outside temperatures without freezing the energy-exchange core.

Some condensation or even frost may form on the outside or drip off of the case during very cold conditions, particularly if the unit runs continuously. Exterior condensation during extreme conditions can be reduced or prevented by periodically cycling the unit off for several minutes to allow the case to warm up.

HE4XINV Airflow Performance

Motor HP	Blower RPM	Turns Open	External Static Pressure (in. w.g.)													
			0.00		0.25		0.50		0.75		1.00		1.25		1.50	
			SCFM	BHP	SCFM	BHP	SCFM	BHP	SCFM	BHP	SCFM	BHP	SCFM	BHP	SCFM	BHP
2 (a)	1191	4	3330	1.4	3015	1.2	2690	1.0	1915	0.8	1085	0.6				
	1329	2	3715	1.9	3440	1.7	3100	1.5	2485	1.3	2000	1.0	1200	0.8		
	1432	0.5	4000	2.4	3740	2.2	3480	2.0	3050	1.7	2490	1.5	1900	1.2	1100	0.9
	1466	0							3200	1.9	2650	1.6	2120	1.3	1385	1.1
3 (b)	1462	3	4060	2.6	3810	2.4	3550	2.1	3180	1.9	2645	1.6	2075	1.3	1345	1.0
	1503	2.5	4175	2.8	3940	2.6	3700	2.4	3340	2.1	2885	1.7	2300	1.5	1600	1.2
	1586	1.5					3950	2.8	3640	2.5	3250	2.3	2745	2.0	2170	1.7
	1668	0.5							3900	3.0	3600	2.7	3155	2.4	2640	2.1
	1710	0									3750	3.0	3350	2.7	2975	2.4
5 (c)	1627	4	4393	3.9	4210	3.7	4050	3.6	3800	3.3	3490	3.1	3020	2.7	2385	2.4
	1731	2					4350	4.3	4150	4.1	3895	3.8	3515	3.5	3055	3.2
	1836	0							4400	5.0	4250	4.7	3970	4.4	3550	4.0

(b) Sheaves for 3HP motors can be adjusted from 1710 RPMs at 0 turns to 1338 RPM at 4.5 turns. Operating range shown is best for motor efficiency.

(c) Sheaves for 5HP motors can be adjusted from 1836 RPMs at 0 turns to 1496 RPM at 6.5 turns. Operating range shown is best for motor efficiency.

Measuring Airflow

Equipment Required

- A magnehelic gauge or other device capable of measuring 0 to 1.5 in. water of differential pressure.
- 2 pieces of natural rubber latex tubing, 1/8" ID, 1/16" Wall works the best. NOTE: Be sure to remove cap from pressure port before inserting tubing. Insure tubing is well seated in pressure ports. NOTE: The tubing should extend in the pressure port approx. 1 inch.

Cross Core Static Pressure Measurement Instructions

- The individual differential static pressures (DSP) can be measured using the installed pressure ports located in the front of the units core access doors. NOTE: These ports have been carefully located on the unit as to give you the most accurate airflow measurement. NOTE: Do not relocate pressure ports.
- To read SCFM of Fresh Air (FA) install the "high" pressure side (+) of your measuring device to the Outside Air (OA) port and the "low" pressure side (-) to the Fresh Air (FA) port.
- To read SCFM of Room Air (RA) install the "high" pressure side (+) of your measuring device to the Room Air (RA) port and the "low" pressure side (-) to the Exhaust Air (EA) port.
- Use the reading displayed on your measurement device to cross reference the CFM output using the conversion chart. NOTE: Be sure to replace cap into pressure port when air flow measuring is completed.

		Differential Static Across Core DSP vs. CFM									
HE4XINV		DSP	0.20	0.30	0.40	0.50	0.60	0.70	0.80	0.90	1.00
	Fresh Air (FA)	CFM	1080	1620	2160	2700	3230	3770	4310	4850	5390
	Room Air (RA)	CFM	1100	1660	2210	2760	3310	3870	4420	4970	5520

CAUTION

The proper operating airflow range for this model is 1000 - 4400 CFM.

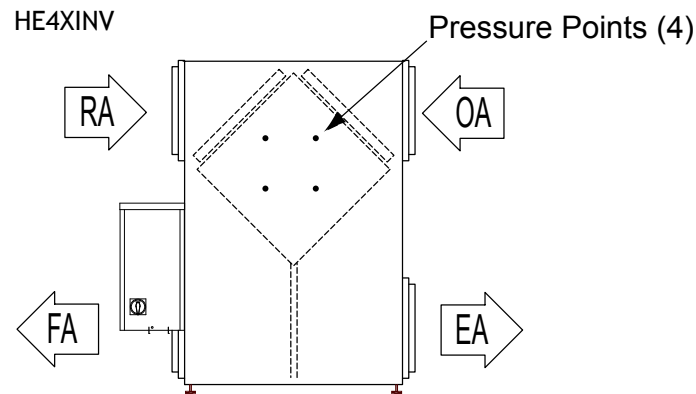

HE4XINV Electrical Specifications

NOTE: Proper Wiring Size Selection and Wiring Installation are the Responsibility of the Electrical Contractor.

Blower & contactor voltages are specified with order and set at factory.

Brake Horsepower at various Blower RPM, Motor Rating, and ESP combinations are available on Spec Sheet or from factory.

Electrical Options and Ratings are identified on the Unit Label (located near electrical box). Find the complete Unit Model Number in the lower left corner of the Unit Label.

⚠ WARNING

Danger of Electrical Shock when servicing an installed unit.

ALWAYS DISCONNECT POWER SOURCE BEFORE SERVICING! More than one disconnect switch may be required.

Proper Wiring Size Selection and Wiring Installation are the Responsibility of the Electrical Contractor.

HE4XINV P1 Wiring Schematics with Independent Blower Control

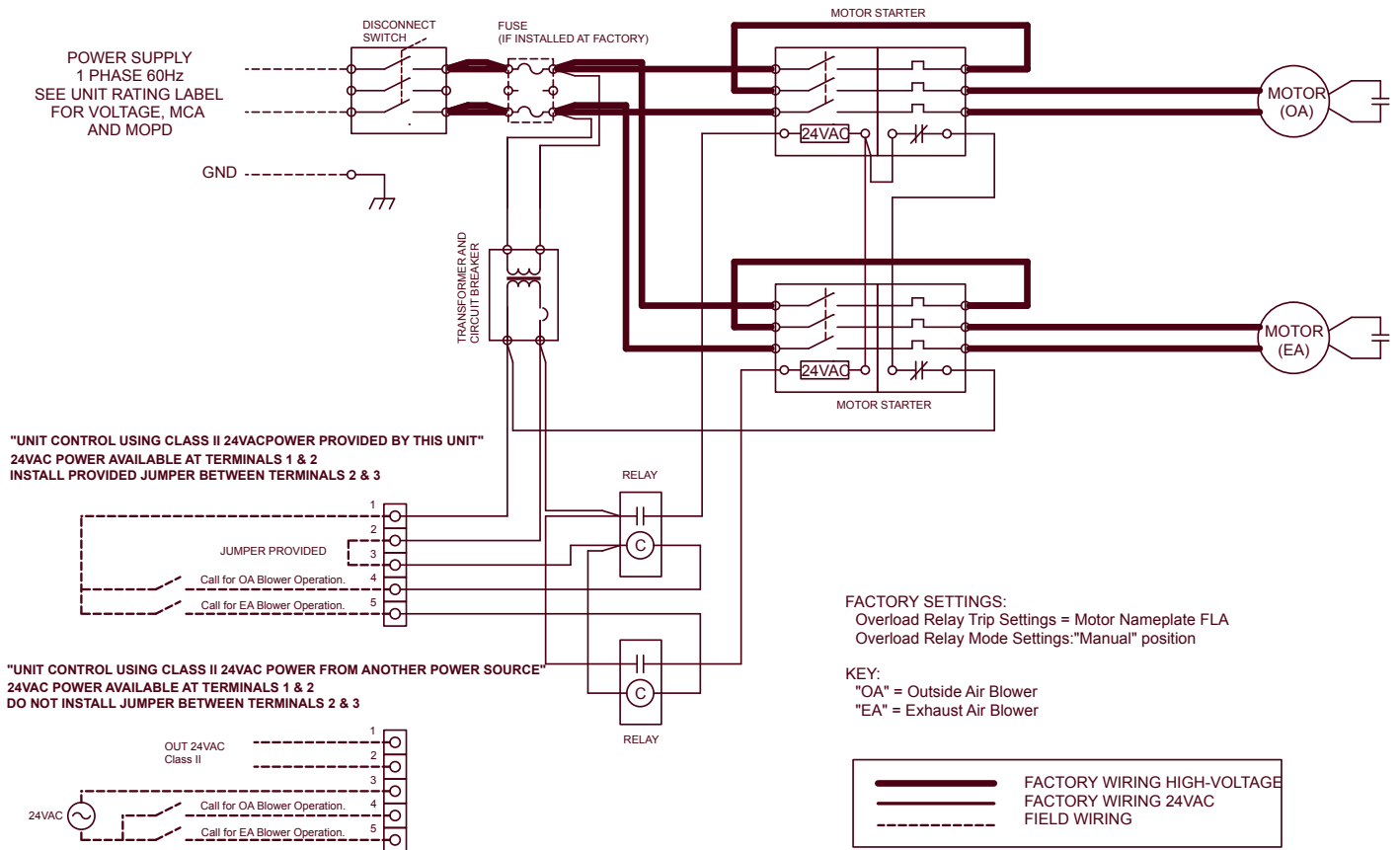

HE4XINV P3 Wiring Schematics with Independent Blower Control

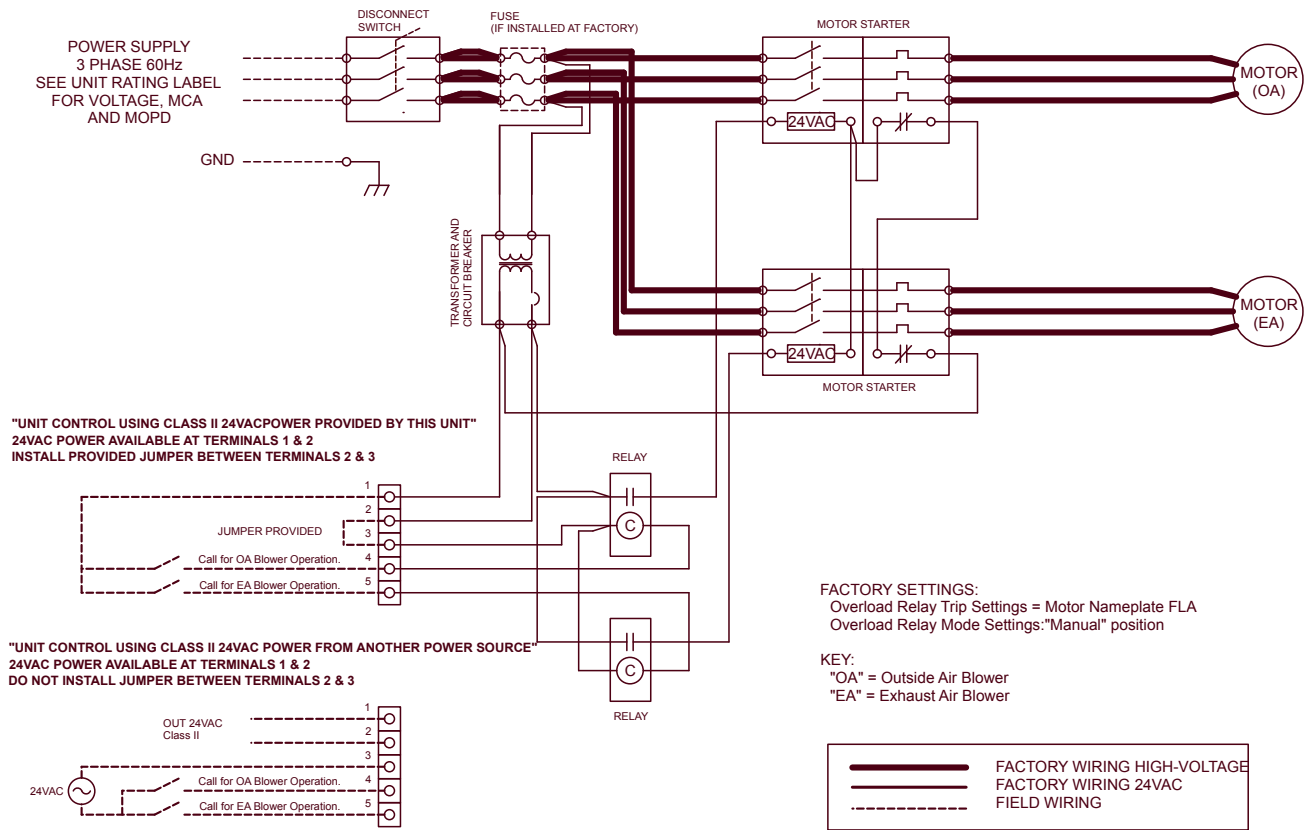

24VAC Power Supply Provided with this ERV Unit

This ERV is provided with a Class II 24VAC power supply system that operates the unit's contactor(s) for EV450 and HE1X. The ERV's 24VAC Power Supply can also be used to power the externally-installed controls system: up to 8VA of power is available.

The unit's power supply system includes isolation relay(s) so you can use external controls whose contact ratings are as low as 50mA (1.2VA). Also, it is possible to operate the isolation relays with 24VAC power from an external source (with proper wiring connections).

A built-in circuit-breaker prevents damage to the transformer and other low-voltage components in the event of a short-circuit or overload. In extreme cases, the transformer itself is designed to fail safely.

CAUTION

1. Connect only to components intended for use with 24VAC power.
2. Do not undersize the low-voltage wires connected to this device. Observe the wire length and gauge limits indicated in this manual.
3. Do not overload this unit's 24VAC power supply system. Confirm that the power requirements of devices you connect to this power supply system do not exceed 8VA in total.
4. If an external source of 24VAC power is used to control the unit, consult the wiring schematics and connect the external power only to the specified terminals in order to avoid damaging the unit or external controls. Connect only CLASS II power to the control terminals of this unit.
5. Unit is not equipped to receive analog signals (such as 1-10vdc or 4-20mA).
6. Unit is not equipped to communicate directly with Building Management Systems (such as BACNET, LONWORKS, etc.). However, the unit can be controlled by powered or non-powered contacts operated by any kind of control system.

Specifications

- Nominal Output Voltage under load: 24VAC
- Typical Output Voltage at no load: 29-31V
- Minimum contact rating for connected control device: (50mA (1.2VA)
- Circuit Breaker Trip Point: 3A

How to Reset the 24VAC Circuit Breaker

If the transformer is subjected to an excessive load or a short circuit, the circuit breaker will trip to prevent the failure of the transformer. When it trips the circuit breaker's button pops up. Shut off the primary-side power to the unit, and remove the excessive load or the short. The circuit breaker can be reset about fifteen seconds after it trips by pressing in the button.

NOTE: INSTALLING CONTRACTOR:

If primary-side voltage is 230VAC, move black primary-side lead from transformer's "208V" terminal to the transformer's terminal marked "240V" ("230V" in some units).

Do not move the black primary-side lead that is connected to the transformer's "COM" terminal.

Limits of Power Output

If limits on wire gauge and length are observed, you may connect control devices that draw up to 8VA to the blue and red wires. More than one device can be connected as long as total steady-state load does not exceed 8VA.

OBSERVE THESE LIMITS TO WIRE LENGTH AND GAUGE, in order to ensure reliable operation of the control system.

Wire Gauge	#22	#20	#18	#16	#14	#12
Circuit Length	100'	150'	250'	400'	700'	1000'

"Circuit Length" is distance from ERV to Control Device.

Motor Starters

This unit uses IEC-style motor starters to protect the motors against overload.

IEC-style motor starters use Overload Relays to detect excessive current and interrupt the control circuit that engages the motor's contactors.

⚠WARNING

The Overload Relay output contacts 95 & 96 must remain in series with the low-voltage control circuit! Altering this will create a hazardous situation in which the motor is not protected against overload!

⚠WARNING

Adhere to applicable local codes when adjusting the dial setting of the overload relays.

Overload Relays are sized to Full Load Amp (FLA) rating of the protected motor. The Overload Relays can be adjusted to trip (interrupt the control circuit) at a specific setting within a range.

Overload Relays should initially be set at the FLA rating of the motor (see Unit Rating Label). If necessary to prevent nuisance tripping at start-up, the Relays can be adjusted to trip no higher than 115% of the motor's FLA rating.

For safest operation, the overload relays should also be used in manual reset mode with trip test capability.

NOTE: As factory-wired, if one blower motor is shut down due to overload by its Motor Starter, the other motor will also be shut down.

NOTE: Terminals 96 & 97 of the Overload Relays and terminals 14 & 13 of the Contactors are normally-open dry contacts that may be used to signal that the contactors are closed and/or that the Overload Relays have tripped.

⚠WARNING

DANGER OF INJURY OR DAMAGE.

The motors in this unit must not be run at an amperage that exceeds the motor's rated full load amps and overload relays on the motor starters must be set at or below motor full load amps. For safest operation, the overload relays should also be used in hand reset mode with trip test capability.

It is the installer's responsibility to measure the operating amperage of each motor. If the full load amp rating is exceeded, the amp draw must be reduced by substituting a smaller motor pulley or by adjusting the variable sheave. Continue these adjustments until the actual amperage is no more than the motor's faceplate full load amps.

Failure to make this adjustment may result in unsafe motor winding temperatures or tripping of the supplied motor starter's overload relay motor protection devices set at full load amps.

⚠WARNING

DANGER OF INJURY OR DAMAGE.

The relay must be set for correct FLA rating depending on the motor horsepower. See Unit Rating Label on motor for HP and FLA specifications.

Control Wiring Schematics

NOTE: The simplified schematics below show only the relevant portions of the low-voltage control circuit in the ERV unit and representational external control approaches. See the complete unit schematics elsewhere in this manual.

- A. **Single 2-wire Control, unpowered:** Use schematic below if the control requires no power from the unit to operate and acts like a simple on/off switch. The control must not supply any power to the ERV unit. Install jumper (provided) between terminals 2 & 3. Connect the control's contacts to terminals 1 & 4 to operate the ERV's Isolation Relay for OA/FA Blower. Install jumper (provided) between terminals 4 & 5 to operate the ERV's Isolation Relay for the RA/EA Blower.

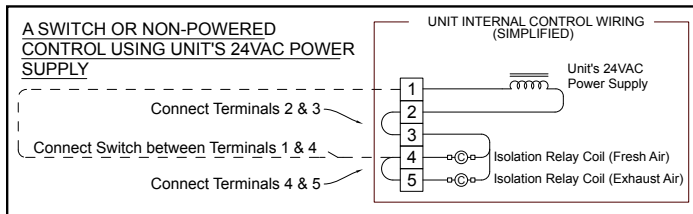

- B. **Single 2-wire Control on separate Power Supply, no power present at Control Output:** Wire as shown for the Single 2-wire control (A. above).

CAUTION

Make sure the control provides no voltage or current at its output terminals.

- C. **Control Sending 24VAC "On" Signal (from an external power source) to ERV:** Make sure jumper is NOT installed between terminals 2 & 3. Now you safely can apply 24VAC to the Terminals 3 & 4 to operate the ERV's Isolation Relay for OA/FA Blower. Install jumper (provided) between terminals 4 & 5 to operate the ERV's Isolation Relay for the RA/EA Blower.

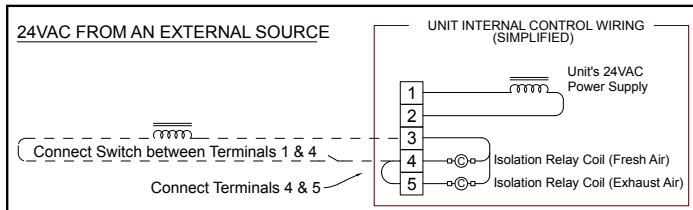

CAUTION

Supply only 24VAC (not VDC) from a Class II Power Source.

- D. **Control operating on Unit's 24VAC Power Supply:** 24VAC power is available at the Terminals 1 & 2. **CAUTION:** external control system should not draw more than 8VA. Install jumper (provided) between terminals 2 & 3.

Connect the switched output of the Control to Terminal 4 to operate the ERV's Isolation Relay for OA/FA Blower. Install jumper (provided) between terminals 4 & 5 to operate the ERV's Isolation Relay for the RA/EA Blower.

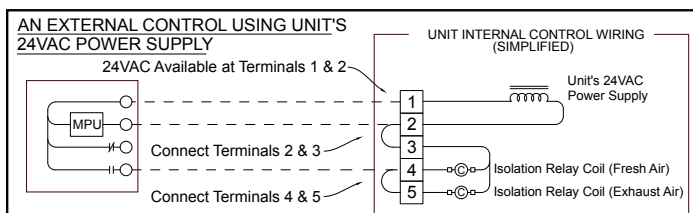

- E. **Control System with 2 Non-powered Relay Contacts:** Use this schematic if the external control system provides no voltage or current at its output contacts. Install jumper (provided) between terminals 2 & 3. Connect one side of each of the output contacts to Terminal 1. Connect the other side of the output contact to control the FA Blower to Terminal 4, and the output contacts to control the EA Blower to Terminal 5.

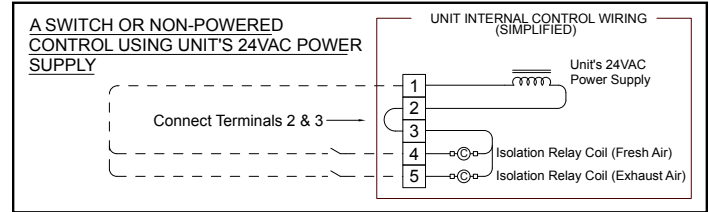

- F. **Control System Sending two 24VAC "On" Signals from an external power source:** Make sure the jumper is NOT installed between Terminals 2 & 3. Now you safely can apply one of the 24VAC signals to Terminals 3 & 4 to operate the ERV's isolation relay for the Fresh Air Blower. Apply the second 24VAC signal to Terminals 3 & 5 to operate the ERV's isolation relay for the Exhaust Blower (make sure the polarity of each wire connected to Terminal 3 is the same).

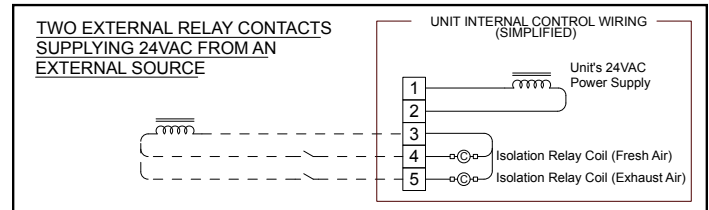

CAUTION

Supply only 24VAC (not VDC) from a Class II Power Source.

- G. **Control System Operating Isolation Dampers with End Switches:** Use Isolation Dampers with electrically separate end switches. The end switches are used to separately control the ERV unit's Isolation Relays. This ensures that each damper is open before the respective blower starts up.

NOTE: Because the ERV's Motor Starters will only be operating once the Dampers are open, the power draw of the Damper Actuators is allowed to be as much as 35VA while opening (including power draw of the external control system, if any). However, the power draw of the fully-opened (stalled) Actuators (and external control system if any) must be less than 8VA. (Most damper actuators have much lower power draws.)

HE4XINV Replacement Parts

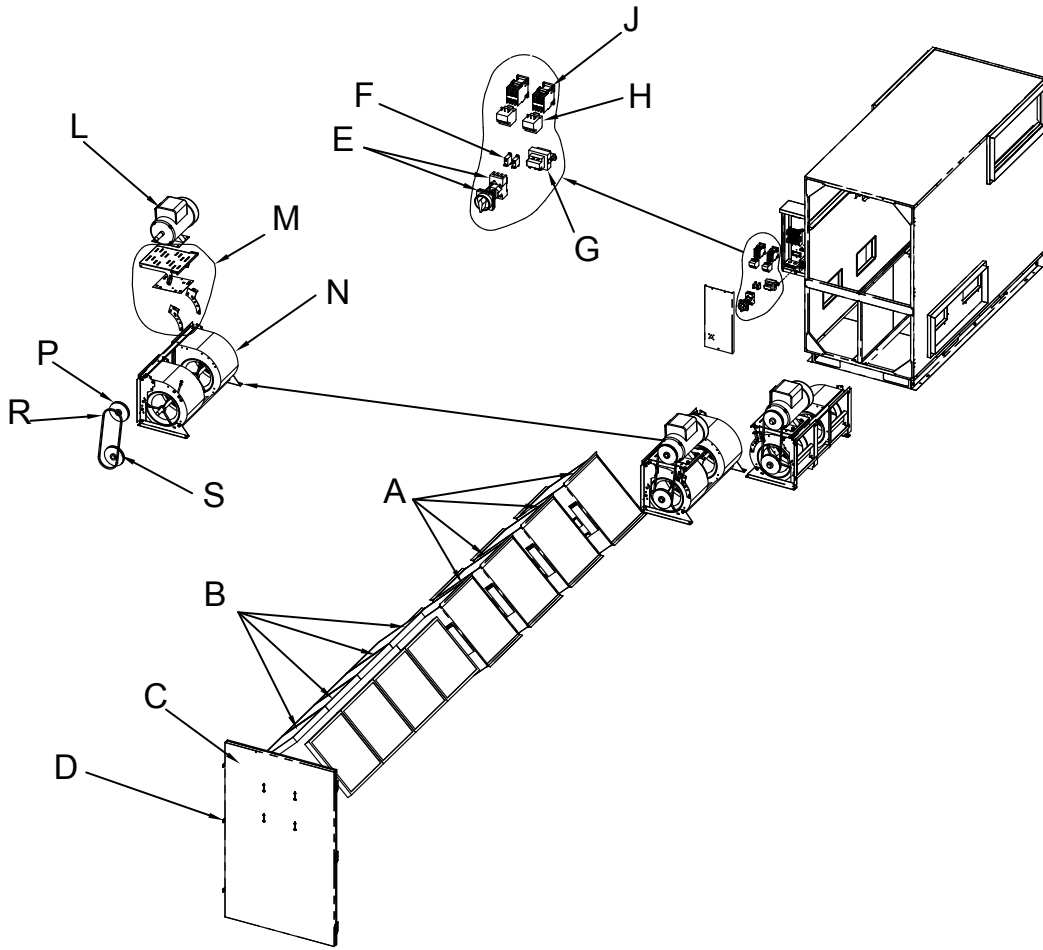

A	CORES
B	FILTERS
C	DOOR
D	DRAW LATCH
E	DISCONNECT SWITCH
F	TRANSFORMER
G	ISOLATION RELAY
H	OVERLOAD RELAY
J	CONTACTOR
L	MOTOR
M	MOTOR MOUNT
N	BLOWER
P	MOTOR SHEAVE
R	BELT
S	BLOWER SHEAVE

Maintenance

SUMMARY MAINTENANCE REQUIREMENTS

Change Filters
Inspect Blower
Tension Blower Belt
General Cleaning and Inspection
Clean Energy Exchange Cores

CHANGING THE FILTERS

Inspect and/or replace filters every two or three months when the unit is in regular use, or as needed.

- Turn off unit completely! Lock-out and tag-out the unit disconnect switch.
- Open the Door. The door is secured with turn-type latches or draw latches, plus one Phillips-head securing screw. Keep the securing screw. NOTE: Always replace securing screw when reinstalling door.
- Remove and dispose of all (8) filters. Replace all (8) filters. NOTE: See chart for information on the initial resistance of the filters originally supplied with this unit. If replacement filters have higher resistance, the airflow of the system will be lower.
- Close door; reinstall securing screw.

Blower Inspection

Inspect Blowers every time you change the filters.

- Confirm bearings are still secure to blower shaft. It should not be possible to move the blower shaft back and forth along its length.
- Confirm blower wheel is not rubbing against the blower inlet or housing.

Blower Belt Tension

Check belt tension every time you change the filters.

- Inspect belt(s) for cracking or uneven wear.
- Check that sheaves are properly aligned so that belt runs straight.

Properly tensioned belt will deflect 0.25" when pressed at the center point with the following force:

2 HP BLOWER - 3 pounds
3 HP BLOWER - 4 pounds
5 HP BLOWER - 5 pounds

GENERAL CLEANING AND INSPECTION

Perform general cleaning and inspection when changing filters.

- Remove dust from blower wheels periodically.
- Remove paper, leaves, etc. from inlet and outlet screens.
- Inspect for insect nests.

TO CLEAN THE ENERGY EXCHANGE CORE

Clean the core annually.

- Remove the filters.
- Vacuum the exposed faces of the energy exchange core with a soft brush.
- Vacuum out dust from the rest of the unit case.
- Install new filters.

⚠ WARNING

Danger of injury from un-guarded drive belts in unit. Disconnect power to unit before opening door.

Danger of injury if unit starts unexpectedly. Switch power off at service disconnect. Lock-out/tag-out the disconnect.

Initial Resistance of Filters supplied with this unit:

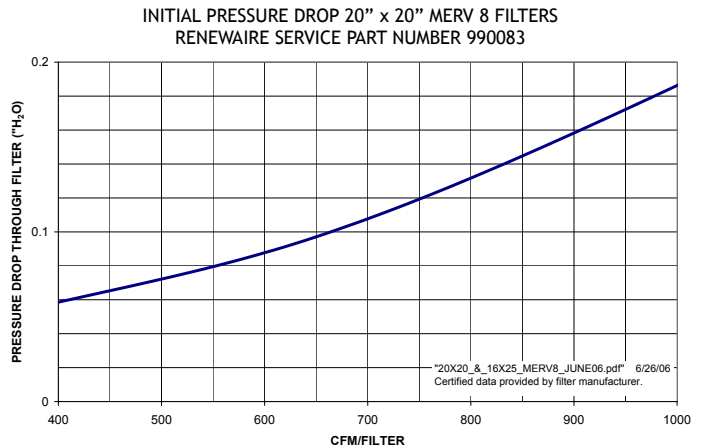

Filter Specifications:

(8) 20" x 20" x 2" (nominal) pleated filters

Actual size: 19.5" x 19.5" x 1.75"

Unit shipped with MERV-8 Filters

Minimum recommended effectiveness: MERV-6

CAUTION

Filters must be used or the energy exchange core will become blocked by dust and the unit will not do its job. In extreme cases components may be damaged.

Lubrication

If the motors used in this ERV are equipped with grease fittings, motors must be lubricated as part of routine maintenance. Use Exxon Polyrex or equivalent at 2500 operating hour intervals.

CAUTION

Incorrect Belt Tension will damage this blower!

CAUTION

DO NOT WASH THE ENERGY EXCHANGE CORE. Keep it away from water or fire to avoid damaging it. Always handle the core carefully.