

LE8XINV

Indoor Unit



Specifications

Ventilation Type: Static Plate, Heat and Humidity Transfer						
Typical Airflow Range: 2,000-8,800 CFM						
AHRI 1060 Certified Core: Eight L125-00						
Airflow Rating Points (for AHRI): 6,000 CFM and 4,500 CFM						
Number Motors: Two belt drive blower/motor packages with adjustable sheaves						
HP	Volts	HZ	Phase	FLA (per motor)	Min. Cir. Amps	Max. Overcurrent Protection Device
3	208-230	60	Single	14.7-14	33.1	40
3	208-230	60	Three	9.38-8.48	21.1	25
	460	60	Three	4.24	9.5	15
	575	60	Three	3.3	7.4	15
5	208-230	60	Three	14.5-13.4	32.6	45
	460	60	Three	6.7	15.1	20
	575	60	Three	5.3	11.9	15
7.5	208-230	60	Three	21.0-18.8	47.3	60
	460	60	Three	9.4	21.2	25
	575	60	Three	7.6	17.1	20
Optional Factory Installed VFD Electrical Specifications						
3	208-230	60	Single	9.38-8.48	40.2	45
3	208-230	60	Three	9.38-8.48	23.2	25
	460	60	Three	4.24	10.5	15
	575	60	Three	3.3	8.2	15
5	208-230	60	Three	14.5-13.4	35.9	45
	460	60	Three	6.7	16.6	20
	575	60	Three	5.3	13.1	15
7.5	208-230	60	Three	21.0-18.8	52.0	60
	460	60	Three	9.4	23.3	25
	575	60	Three	7.6	18.8	20
Standard Features: Totally Enclosed Premium Efficiency Motors Motor Starters, Non-fused Disconnect 24 VAC Transformer/Relay Package						
Filters: Sixteen total, MERV 8, 2" pleated, 20" x 25" nominal size MERV 13 and/or 4" pleated options available						
Weight: 2,630 lbs (unit), 2,930 lbs (shipping weight, on pallet) may be shipped in 2 modules						
Shipping Dimensions: Per Module 92" L x 90" W x 82" H One Piece 172" L x 90" W x 82" H						
Options: Fused disconnect Double wall construction Factory supplied and mounted Variable Frequency Drives (VFDs) – one or both airstreams Motorized isolation dampers, EA, FA or both airstreams Factory mounted Filter Alarms (2)						

G5 Performance

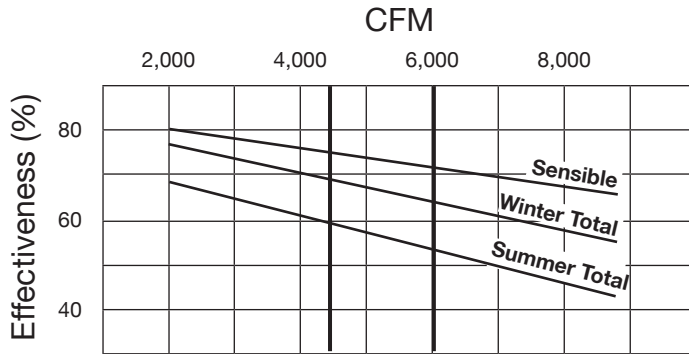

*At AHRI 1060 standard conditions
(See certified data on page 73 for core components.)

Airflow Performance

Motor HP	Blower RPM	Turns Open	External Static Pressure (in. w.g.)																	
			0.00		0.25		0.50		0.75		1.00		1.25		1.50		1.75		2.00	
			CFM	BHP	CFM	BHP	CFM	BHP	CFM	BHP	CFM	BHP	CFM	BHP	CFM	BHP	CFM	BHP	CFM	BHP
3	632	6	5250	1.5	4120	1.3	2840	1.0												
	673	5	5800	1.8	4680	1.6	3400	1.3												
	714	4	6350	2.2	5290	1.9	4050	1.6	2500	1.2										
	755	3	6910	2.5	5910	2.3	4750	1.9	3300	1.5										
	796	2	7460	3.0	6530	2.7	5450	2.4	4140	2.0	2300	1.4								
	837	1	8000	3.4	7130	3.2	6140	2.8	4970	2.4	3430	1.9								
5	773	6	7150	2.7	6180	2.4	5060	2.1	3670	1.7	1630	1.1								
	815	5	7710	3.2	6810	2.9	5780	2.6	4530	2.2	2830	1.6								
	857	4	8250	3.7	7420	3.4	6470	3.1	5360	2.7	3930	2.2								
	898	3	8780	4.3	7990	4.0	7120	3.6	6120	3.2	4890	2.8	3180	2.1						
	940	2			8570	4.6	7760	4.3	6850	3.9	5780	3.4	4420	2.8	2120	1.8				
	982	1			8800	5.0	8390	5.0	7550	4.6	6590	4.1	5440	3.6	3890	2.8				
7.5	1000	6					8660	5.3	7850	4.9	6930	4.4	5840	3.9	4450	3.2				
	1041	5						8510	5.7	7660	5.2	6690	4.7	5520	4.1	3960	3.2			
	1082	4							8370	6.1	7480	5.6	6460	5.0	5210	4.2	3430	3.2		
	1122	3							8800	7.1	8240	6.5	7310	5.9	6220	5.2	4870	4.3		
	1163	2									8800	7.6	8140	7.0	7160	6.3	6020	5.5		
	1204	1													8070	7.5	7040	6.7		

Note: Brake Horse Power (BHP) is for one blower motor package only.

Operation in this zone will likely exceed FLA limits. Operation in this zone outside of core airflow limits.

LE8XINV Unit Dimensions

EA: Exhaust Air to outdoors
 OA: Outdoor Air intake
 RA: Room Air to be exhausted
 FA: Fresh Air to inside

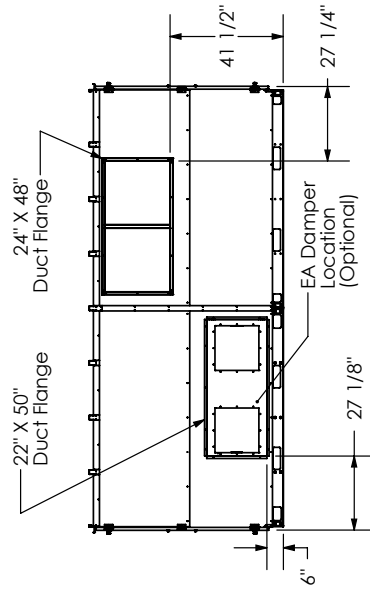
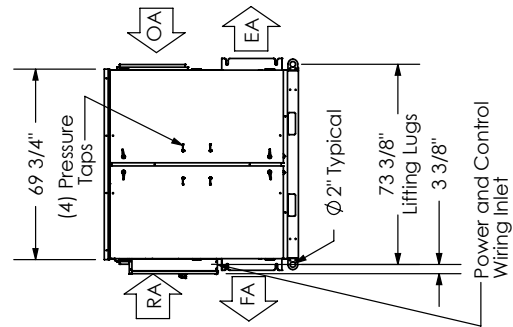
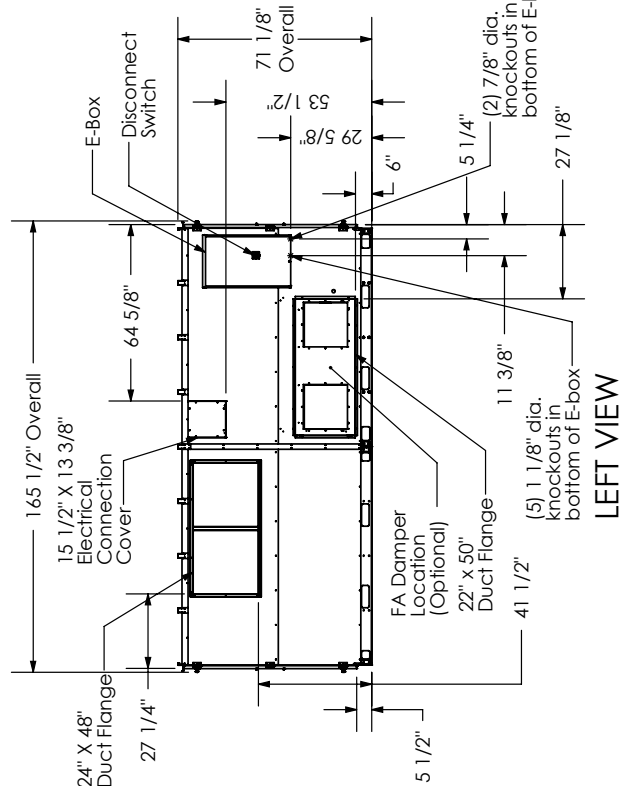
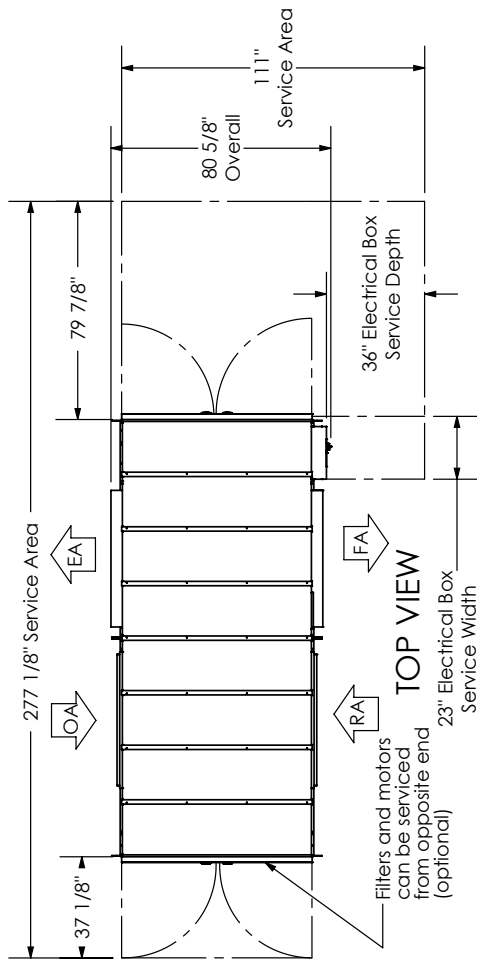

FRONT VIEW

RIGHT VIEW