

# LE6XRT

## Outdoor Unit



## Specifications

Ventilation Type: Static Plate, Heat and Humidity Transfer						
Typical Airflow Range: 1,500-6,600 CFM						
AHRI 1060 Certified Core: Six L125-00						
Airflow Rating Points (for AHRI): 4,500 CFM and 3,375 CFM						
Number Motors: Two belt drive blower/motor packages with adjustable sheaves						
HP	Volts	HZ	Phase	FLA (per motor)	Min. Cir. Amps	Max. Overcurrent Protection Device
3	208-230	60	Single	14.7-14	33.1	40
3	208-230	60	Three	9.38-8.48	21.1	25
	460	60	Three	4.24	9.5	15
	575	60	Three	3.3	7.4	15
5	208-230	60	Three	14.5-13.4	32.6	45
	460	60	Three	6.7	15.1	20
	575	60	Three	5.3	11.9	15
7.5	208-230	60	Three	21.0-18.8	47.3	60
	460	60	Three	9.4	21.2	25
	575	60	Three	7.6	17.1	20
Optional Factory Installed VFD Electrical Specifications						
3	208-230	60	Single	9.38-8.48	40.2	45
3	208-230	60	Three	9.38-8.48	23.2	25
	460	60	Three	4.24	10.5	15
	575	60	Three	3.3	8.2	15
5	208-230	60	Three	14.5-13.4	35.9	45
	460	60	Three	6.7	16.6	20
	575	60	Three	5.3	13.1	15
7.5	208-230	60	Three	21.0-18.8	52.0	60
	460	60	Three	9.4	23.3	25
	575	60	Three	7.6	18.8	20
Standard Features: Totally Enclosed Premium Efficiency Motors Motor Starters, Non-fused Disconnect 24 VAC Transformer/Relay Package						
Filters: Twelve total, MERV 8, 2" pleated, 20" x 25" nominal size MERV 13 and/or 4" pleated options available						
Weight: 2,220 lbs (unit), 2,520 lbs (shipping weight, on pallet) may be shipped in 2 modules						
Shipping Dimensions: Per Module 80" L x 90" W x 82" H One Piece 160" L x 90" W x 82" H						
Options: Fused disconnect Double wall construction Factory supplied and mounted Variable Frequency Drives (VFDs) – one or both airstreams Motorized isolation dampers, OA, EA or both airstreams Factory mounted Filter Alarms (2) Exterior Paint - white standard (custom colors available)						

## G5 Performance

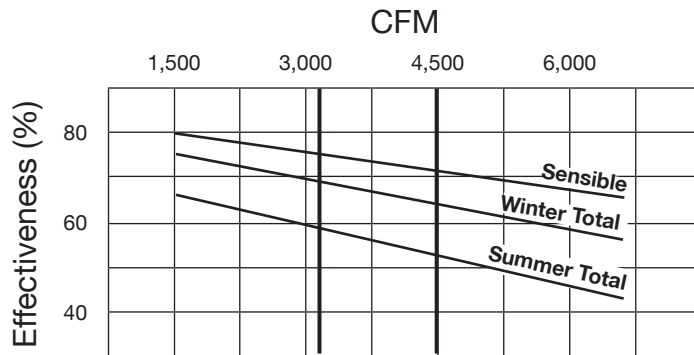

\*At AHRI 1060 standard conditions  
(See certified data on page 73 for core components.)

## Base Type/Airflow Orientations

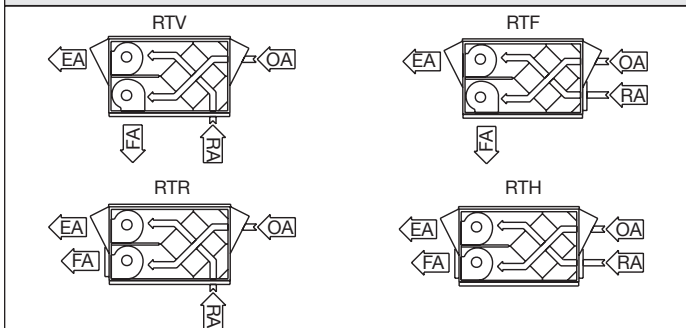

## Airflow Performance

Motor HP	Blower RPM	Turns Open	External Static Pressure (in. w.g.)																		
			0.00		0.25		0.50		0.75		1.00		1.25		1.50		1.75		2.00		
			CFM	BHP	CFM	BHP	CFM	BHP	CFM	BHP	CFM	BHP	CFM	BHP	CFM	BHP	CFM	BHP	CFM	BHP	
3	632	6	3340	1.1	2750	1.0	1580	0.7													
	673	5	3590	1.3	3080	1.1	2130	0.8													
	714	4	3850	1.5	3390	1.3	2680	1.0													
	755	3	4110	1.7	3700	1.5	3120	1.3													
	796	2	4400	2.1	4010	1.8	3500	1.6	2660	1.2											
	837	1	4710	2.4	4330	2.2	3870	1.9	3220	1.5											
5	773	6	4240	1.9	3830	1.7	3290	1.4	2180	0.9											
	815	5	4540	2.2	4160	2.0	3670	1.7	2940	1.3											
	857	4	4870	2.6	4490	2.4	4040	2.1	3450	1.7	2160	1.1									
	898	3	5220	3.1	4850	2.8	4420	2.5	3880	2.1	3110	1.7									
	940	2	5630	3.7	5250	3.4	4820	3.0	4320	2.6	3670	2.2	2520	1.6							
	982	1	6090	4.4	5690	4.0	5250	3.6	4760	3.2	4170	2.7	3390	2.2							
7.5	1000	6	6310	4.7	5890	4.3	5450	3.9	4960	3.4	4380	3.0	3660	2.5	2890	2.2					
	1041	5	6550	5.2	6370	5.1	5910	4.6	5410	4.1	4860	3.6	4210	3.0	3330	2.5					
	1082	4			6605	5.5	6370	5.3	5870	4.8	5330	4.2	4720	3.7	3980	3.1	2870	2.5			
	1122	3					6550	5.7	6260	5.5	5750	4.9	5180	4.3	4530	3.7	3690	3.2	2850	2.9	
	1163	2							6550	6.1	6090	5.5	5580	4.9	5000	4.4	4310	3.8	3360	3.2	
	1204	1								6630	6.3	6300	6.0	5860	5.5	5370	5.0	4790	4.4	4060	3.9

Note: Brake Horse Power (BHP) is for one blower motor package only.

Operation in this zone will likely exceed FLA limits.

Operation in this zone outside of core airflow limits.

# LE6XR

## Unit Dimensions

- EA: Exhaust Air to outdoors
- OA: Outdoor Air intake
- RA: Room Air to be exhausted
- FA: Fresh Air to inside

### Curb Cross Section

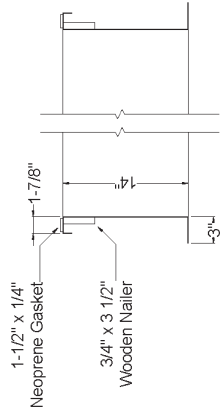

### CURB6XLXLE

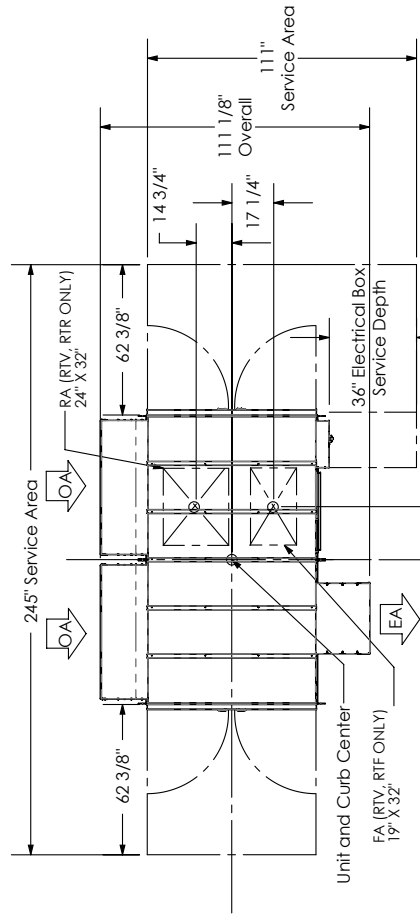
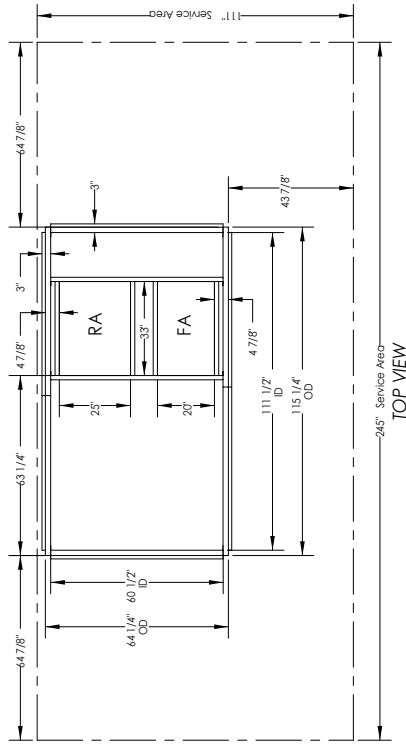

### TOP VIEW

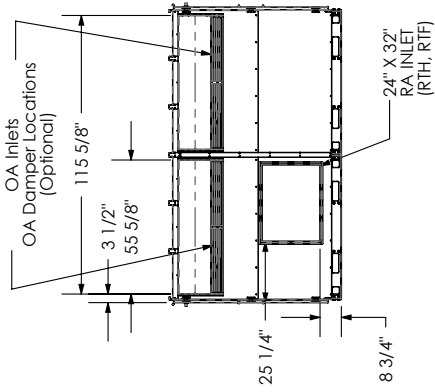

### RIGHT VIEW

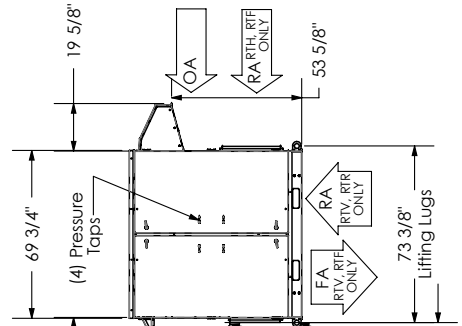

### FRONT VIEW

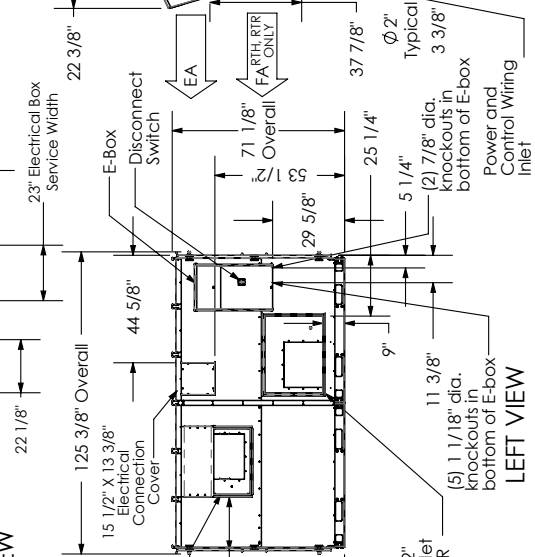

### LEFT VIEW