

LE8XRT

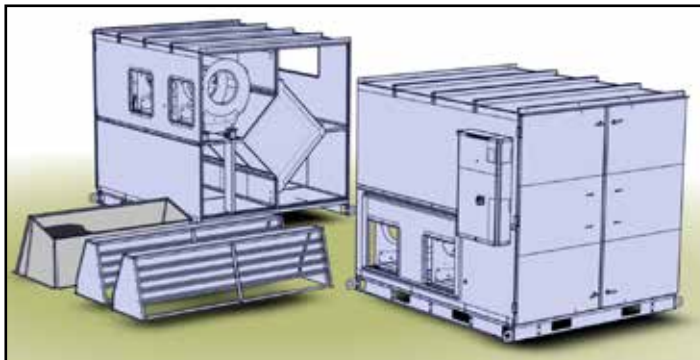
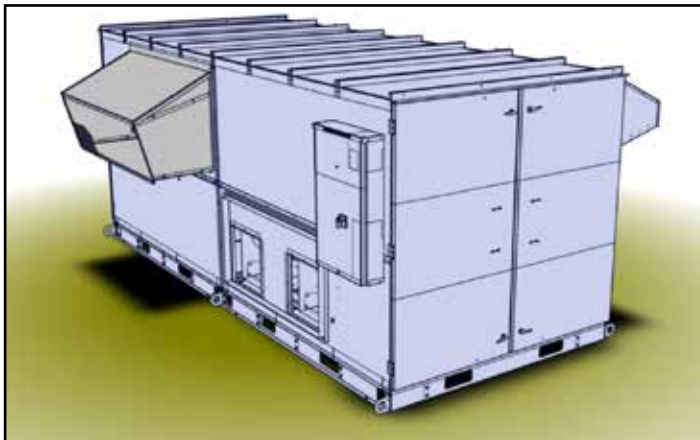

Table of Contents

FOR THE SPECIFIER AND INSTALLER.....	2
FOR THE ELECTRICIAN.....	8
FOR THE CONTROL CONTRACTOR.....	12
FOR THE TEST, BALANCE, & COMMISSIONING CONTRACTOR..	15
SERVICE PARTS.....	18
MAINTENANCE.....	19

NOTE

LE8XRT can be delivered in two modules for on-site assembly or as a complete unit (additional charges apply).

In all cases the exhaust and outdoor air weatherhoods ship loose and require later installation on the unit.

See Separate SHIPPING & RIGGING Manual for information on shipping considerations, and moving and lifting the unit as separate modules or as a complete unit.

⚠ WARNING

1. Before servicing or cleaning the unit, switch power off at disconnect switch or service panel and lockout/tag-out to prevent power from being switched on accidentally. More than one disconnect switch may be required to de-energize the equipment for servicing.
2. This installation manual shows the suggested installation method. Additional measures may be required by local codes and standards.
3. Installation work and electrical wiring must be done by qualified professional(s) in accordance with all applicable codes, standards and licensing requirements.
4. Any structural alterations necessary for installation must comply with all applicable building, health, and safety code requirements.
5. This unit must be grounded.
6. Danger of severe injury to bystanders and damage to unit or property if high winds move this unit. Secure this unit to the building!
7. Sufficient air is needed for proper combustion and exhausting of gases through the flue (chimney) of fuel burning equipment that might be installed in the area affected by this equipment. If this unit is exhausting air from a space in which chimney-vented fuel burning equipment is located, take steps to assure that combustion air supply is not affected. Follow the heating equipment manufacturer's requirements and the combustion air supply requirements of applicable codes and standards.
8. Use the unit only in the manner intended by the manufacturer. If you have questions, contact the manufacturer.
9. This unit is intended for general ventilating only. Do not use to exhaust hazardous or explosive materials and vapors. Do not connect this unit to range hoods, fume hoods or collection systems for toxics.
10. When cutting or drilling into wall or ceiling, do not damage electrical wiring and other hidden utilities.



FOR THE SPECIFIER AND INSTALLER

CAUTION

To avoid motor bearing damage and noisy and/or unbalanced impellers, keep drywall spray, construction dust, etc., out of unit.

CAUTION

Do not remove or disable the wiring interconnection between the Overload Relays and the Contactors. Without this interconnection the motor(s) will not be protected against overload.

PHYSICAL CONFIGURATION OPTIONS

The LE8XRT is available from the factory in four different configurations to meet different connection requirements:

Option Code	Description of Duct Connection Configuration	Mounting Option
LE8XRTV	Room Air [RA] enters bottom of unit. Fresh Air [FA] exits bottom of unit.	Roof Curb
LE8XRTR	Room Air [RA] enters bottom of unit. Fresh Air [FA] exits side of unit.	Roof Curb
LE8XRTF	Room Air [RA] enters side of unit. Fresh Air [FA] exits bottom of unit.	Roof Curb
LE8XRTH	Room Air [RA] enters side of unit. Fresh Air [FA] exits side of unit.	Equipment Rail

NOTE: Before installing unit, confirm the duct configuration was specified correctly for your installation requirements.

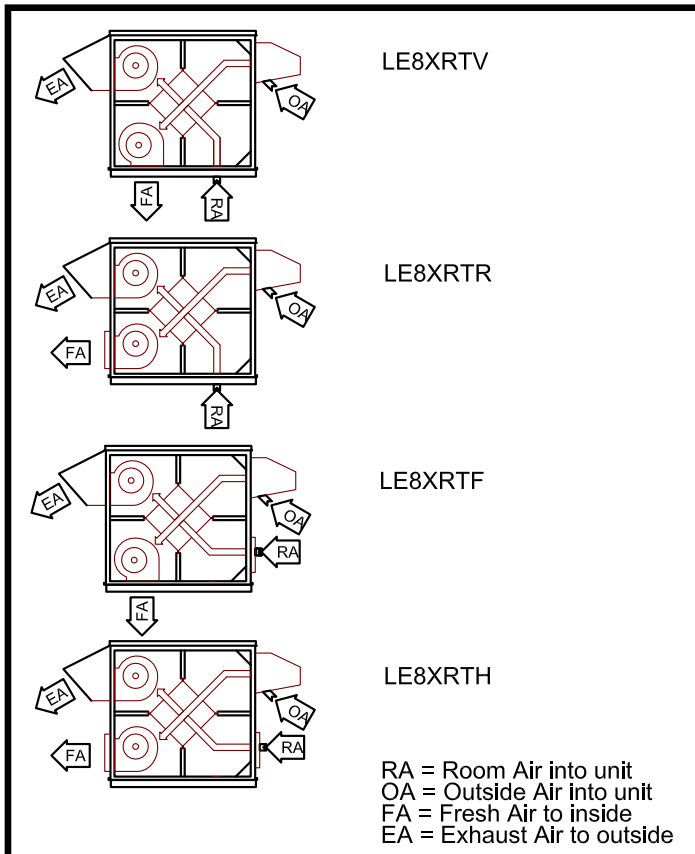

NOTE: Provide service access to the unit to allow for cleaning the core and filter.

⚠ WARNING

Danger of carbon monoxide poisoning!

The outside air intake should be at least 10' away from exhausts such as dryer vents, chimneys, furnace and water heater exhausts, or other sources of contamination or carbon monoxide.

Do not locate outside air intake where vehicles may be serviced or left idling.

Never locate the outside air inlet inside a structure.

LE SERIES CONFIGURATION CHART

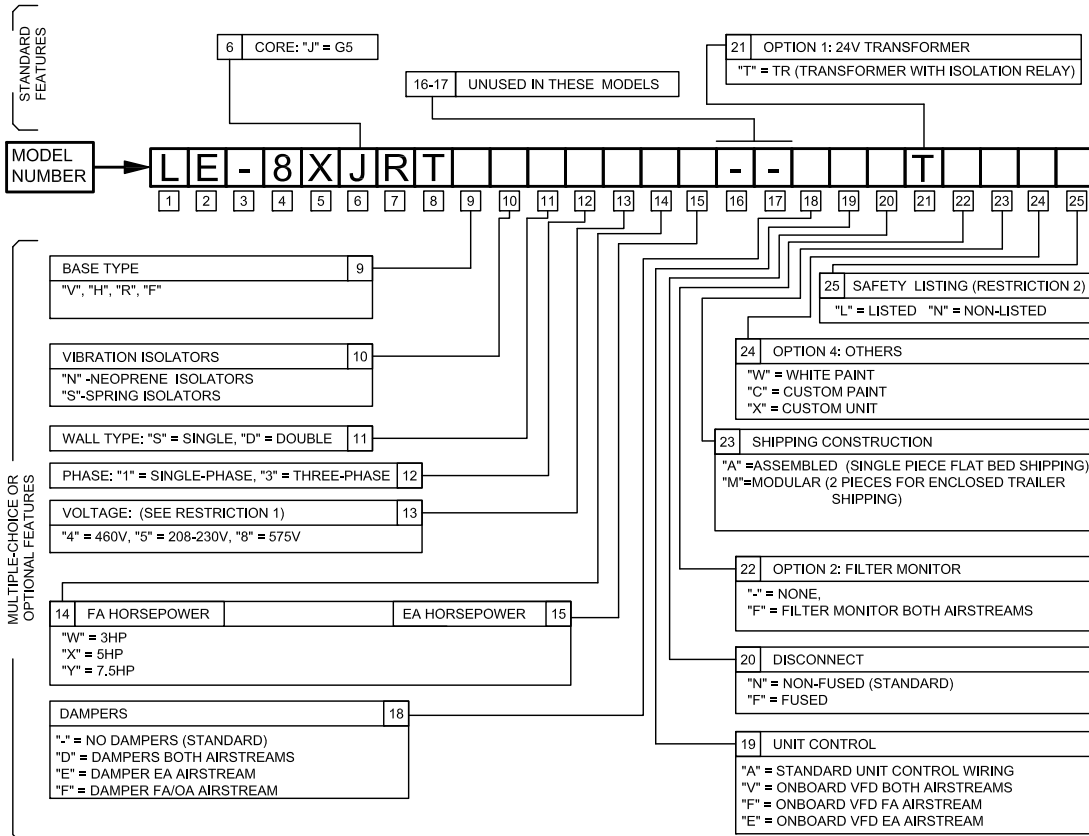

RESTRICTIONS:

- VOLTAGE CODES "4" & "8" AVAILABLE WITH PHASE CODE "3" (THREE-PHASE) ONLY.
- SOME UNITS WITH CUSTOM "X" CODE ARE NOT SAFETY LISTED.

LE8XRT DIMENSIONS DRAWING

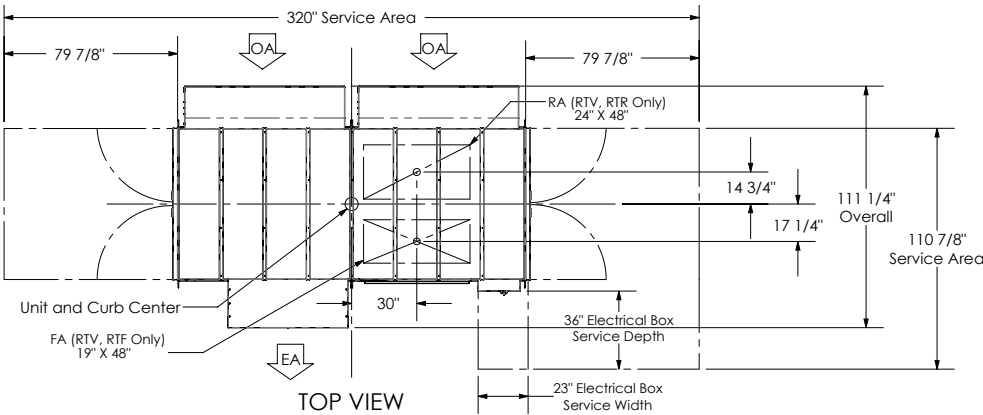

NOTE: Provide service access to allow for cleaning the core and filter replacement.

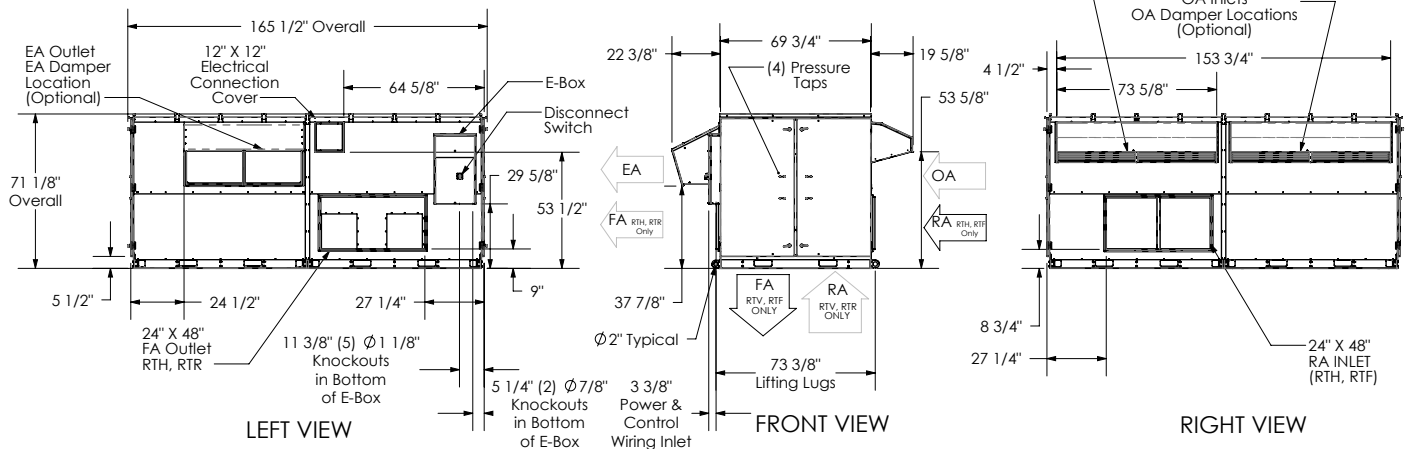

COGS AND CORNER WEIGHTS

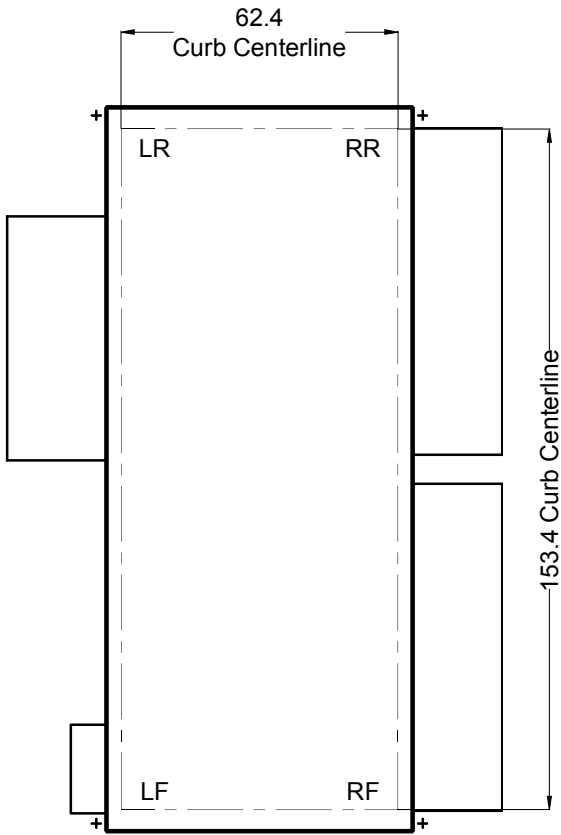

BASIC UNIT WEIGHTS (lbs.)					
Motors	UNIT	LF	LR	RR	RF
3 HP	2631	764	677	559	631
5 HP	2645	759	738	566	582
7.5 HP	2763	807	784	578	594
ADDITIONAL WEIGHTS FOR OPTIONS (lbs.)					
Motors	UNIT	LF	LR	RR	RF
Double Wall	524	131	131	131	131
VFDs	15	14	1	0	0
EA Damper	21	6	16	-1	0
OA Damper	42	-2	-1	18	27
Total Selected Weights					
Add the additional weights for options to the Basic Unit weights determined by motor size to determine Unit and Corner weights for a specific unit.					
Corner weights shown above include hoods installed on the unit.					

CORNER WEIGHTS AT CORNERS OF CURB

CURBS

On Roof Curbs:

The base of the LE8XRT Unit is designed for installation on our optional Roof Curb. See drawing below.

Before installing LE8XRT, apply roofing and counterflashing to Roof Curb as per standard practice.

Install appropriate gasket on top of Roof Curb.

See Also "OPTIONAL CURB CLIPS", below, for an example of curb-to-roof-deck fastener schedule appropriate for a specific wind load.

On Equipment Rails:

Review drawing of Roof Curb and specify Equipment Rail to fit.

Before installing LE8XRT, apply roofing and counterflashing to Equipment Rails as per standard practice.

CAUTION

Air leakage from the conditioned space below the roof into the space between inside the curb can cause problems including:

- Condensation inside the curb in cold weather, to the point that water drips into the building and damages duct insulation or furnishings.
- Leakage of noise from the unit into the space below. Holes through the roof deck for the ducts should be cut close to the ducts and the gaps should be sealed.

CURB DIMENSIONS

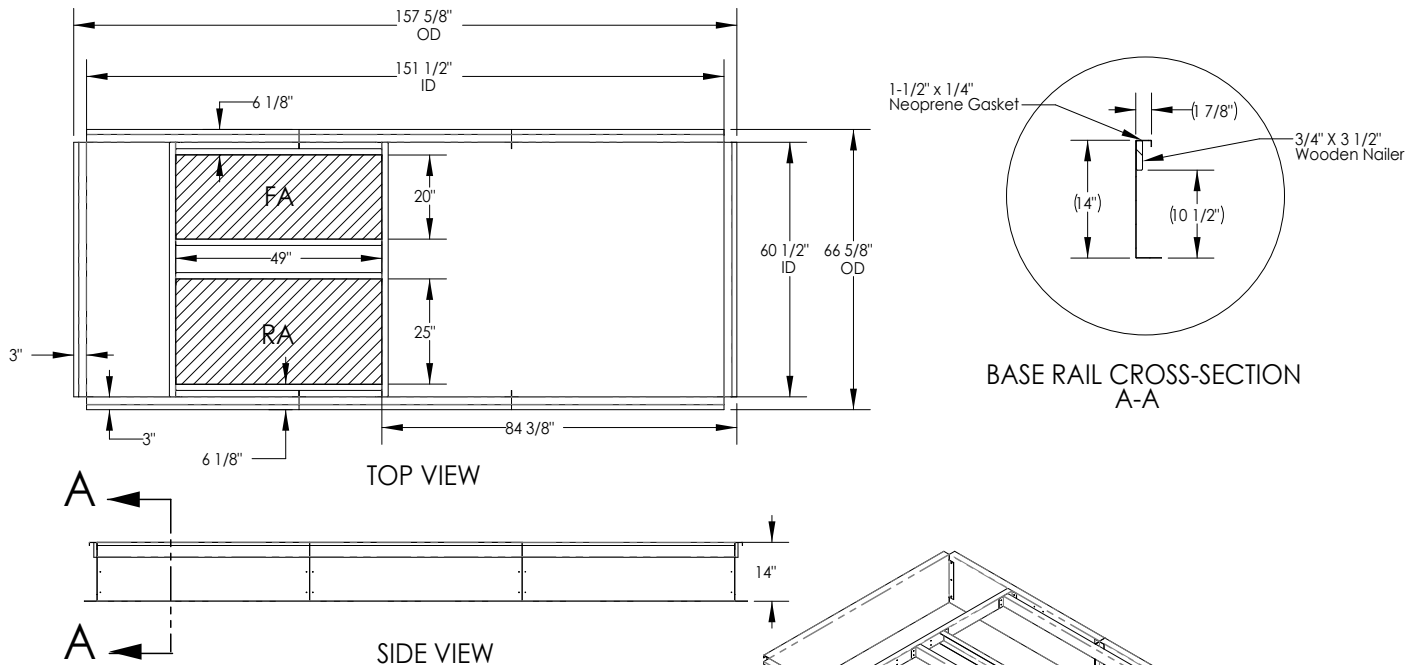

SECURE UNIT TO THE CURB OR EQUIPMENT RAILS

RenewAire strongly recommends that you secure rooftop units properly to the curb or equipment rails, and thus to the building structure. Strong winds, tornados, and hurricanes can and do displace or remove rooftop equipment from rails or curbs. When this happens, the equipment, adjacent roof structure, and even vehicles parked near the building can be damaged, and rain typically enters the building. The equipment is put out of service and the collateral damage can be very expensive.

At a minimum, observe locally applicable codes, but note that even if local codes require some attachment means that may not be enough to withstand common wind occurrences.

OPTIONAL CURB CLIPS

If the optional Curb Clip Kit was supplied, the Clips must be installed on the curb before installing the unit. REFER TO INSTRUCTIONS SUPPLIED WITH THE CURB CLIP KIT.

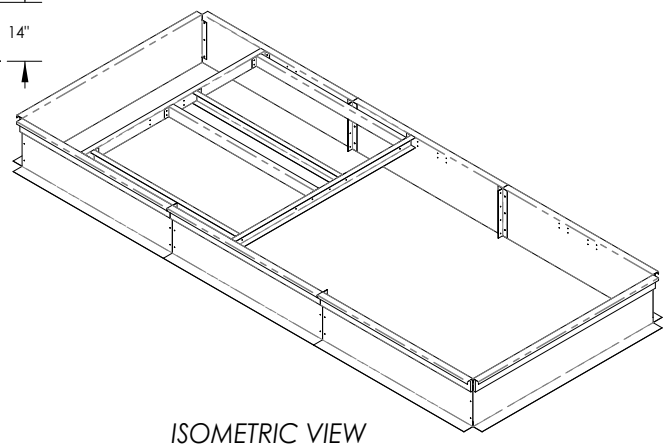

WARNING

Danger of damage or severe injury if high winds move this unit. Secure unit to structure! Observe local code requirements at a minimum!

VIBRATION ISOLATION

LE-Series units are standardly supplied with vibration isolators for the motor/blower assemblies. Both neoprene and spring vibration isolators are offered. Spring isolators are externally adjustable with elastomeric snubbers. The standard isolators are not seismic-rated. See table for additional technical information.

Blower discharges are connected to the Outlets with flexible duct to minimize vibration bypass around the isolators.

CAUTION

Possible damage to equipment if the motor/blower assembly vibration isolators are used with whole-unit spring isolation, such as isolation curbs. If an isolation curb is to be used, the LE- unit must be special-ordered with no internal vibration isolators.

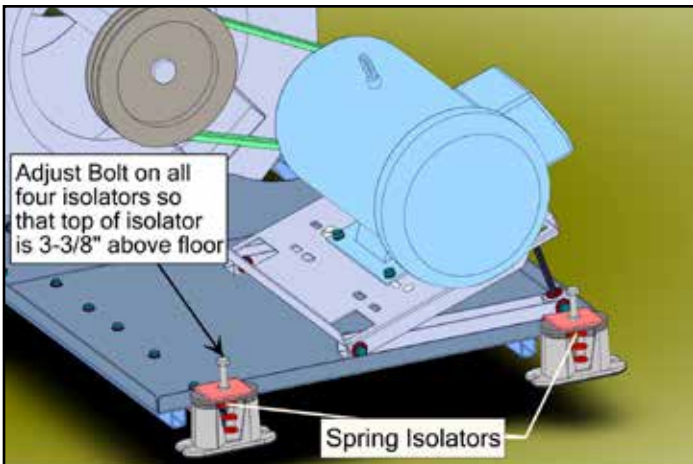
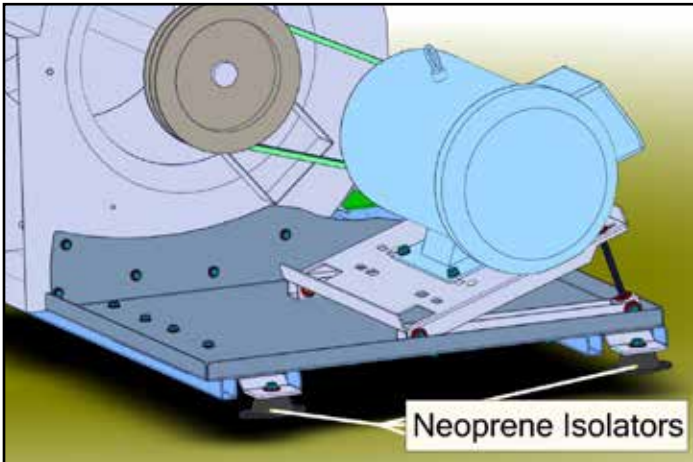

VIBRATION ISOLATOR SPECIFICATIONS, DESIGN LOADS AND DISTURBING FREQUENCIES

Isolator Type	NEOPRENE		SPRING	
	Motor End (Black)	Blower End (Blue)	Motor End (Red)	Blower End (Tan)
Isolator Location				
Quantity	2	2	2	2
Rated Max Load (lbs)	170	135	150	100
Rated Max Deflection (in.)	0.25	0.25	1.00	1.00
Spring Rate (LB/IN)	680	540	150	100
Design Load (LB each)*	95-105	75-85	95-105	75-85
Final Height	Not adjustable		Adjust to 3-3/8"	
Disturbing Frequencies: 60 Hz (power line frequency) 29.0-29.3 Hz (motor speed), 10-20 Hz (blower speed).				
*Exact Design Load varies depending on motor HP				

DUCT CONNECTIONS

Any duct connections to the sides of the unit are equipped with double-flanged duct connections. These allow for connection of ducts insulated on the inside or the outside, or for installation of lined duct.

Connect ducts to these flanges with standard S-Slips. Seal duct exterior to the unit to keep the weather out.

Any duct connections to the bottom of the unit are made to the duct supports on the optional roof curb. The sizes of the duct openings in the curb allow for 1" of insulation on duct in addition to duct ID sizes shown on dimension drawings, page 5.

CAUTION

If the inside ducts run through un-conditioned spaces, they must be insulated, with a sealed vapor barrier on both inside and outside of insulation.

CAUTION

Any ductwork that is exposed to the weather must be properly insulated and weather-proofed.

SOUND ATTENUATION

Outside the building:

The exhaust hood is the primary source of noise outside the building. When practical, orient the exhaust air hood to point away from houses or public areas.

At the Curb:

Cut the holes in the roof deck to fit closely around the duct(s) passing through the roof deck. Seal all gaps around the duct(s) at the roof deck.

Duct Stiffness:

Make sure the ductwork at the unit outlets is stiff enough to resist the flexure and resulting booming associated with system start-up and shut-off, as well as the turbulent flow conditions at the blower outlets.

In general, provide smooth transitions from the ERV's outlets to the duct. The ducts connecting to the outlets should be straight for a sufficient distance, with gradual transitions to the final duct size. These guidelines are consistent with SMACNA recommended duct layout practices for efficient and quiet air movement. Follow SMACNA guidelines.

Radiated Noise:

The LE8XRT is insulated with high-density fiberglass. This provides significant attenuation of radiated sound from the unit itself.

The outlet ducts can be significant sources of radiated sound as well. The FA duct should be insulated for sound control. This insulation should start at the unit. At a minimum the first ten feet of duct should be insulated. All parts of the FA and RA ducts located in a mechanical space with noise-generating equipment also should be insulated for sound control, both to minimize sound radiation out of the FA duct, and also to control sound radiation into both ducts.

SETTING AND INSTALLING THE UNIT ON THE CURB OR EQUIPMENT RAILS

Install ducts that pass through the curb before setting the unit.

Install optional Curb Clips to the Curb before setting the unit.

See separate Shipping & Rigging Manual.

INSTALLING THE WEATHERHOODS

NOTE: If Unit is equipped with Outside Air Dampers AND was shipped in two modules, a control wiring interconnection for the two dampers must be completed before installing the Outside Air Weatherhoods. See Page 9 for instructions.

Outside Air Hood (see illustration):

Remove and keep the screws from the roof panel overhang.

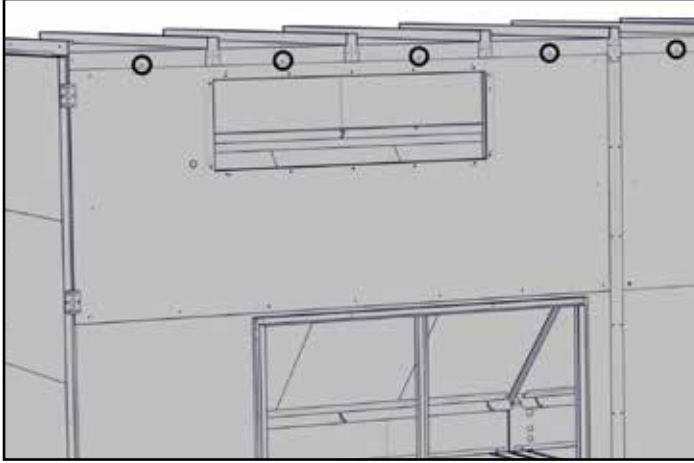

Slide the top flange of the Outside Air Hoods under the roof panel overhang.

Reinstall screws.

Install screws along sides and lower flange of hoods.

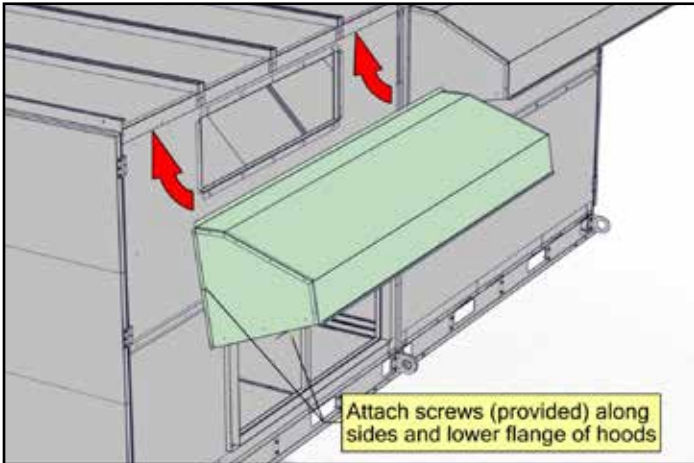

Exhaust Air Hood (see illustration):

Remove and keep the screws from the upper side panel overhang.

Slide the top flange of the Outside Air Hoods under the upper side panel overhang.

Reinstall screws.

Install screws along sides and lower flange of hoods.

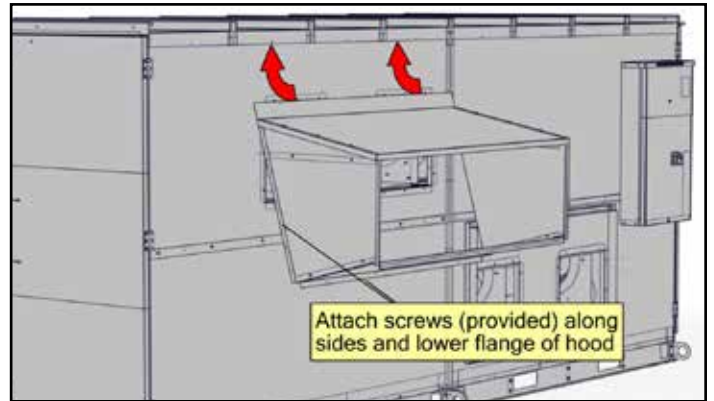
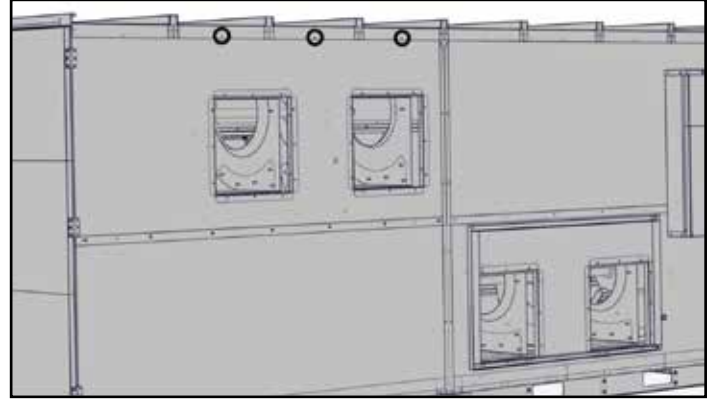

FOR THE ELECTRICIAN

Units shipped in two modules ONLY:

INTERNAL WIRING CONNECTIONS ARE REQUIRED AFTER MODULES ARE FASTENED TOGETHER, AND BEFORE CONNECTION OF UNIT SUPPLY POWER. Refer to following:

For INH and RT models, the back module comes pre-wired with the exhaust air blower wires being routed from the motor to the open end of the module. The ends of the wires are connected to a plug.

If the back module is equipped with isolation damper(s), they are also pre-wired with the damper wires being routed from the damper actuators to the open end of the module. The ends of the wires are connected to plugs.

Once the modules are set in place and fastened together, open the electrical connection cover on the electrical box side of the front module by removing screws in the access panel. The access panel is located in the upper rear corner of the front module.

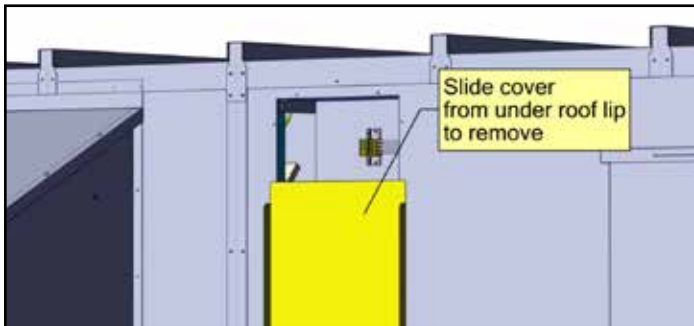
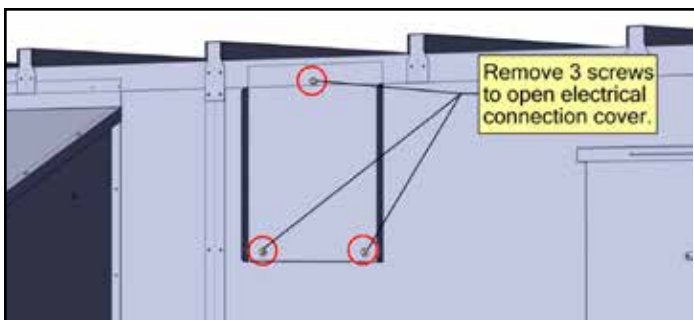

Inside the access panel there is a high and low voltage compartment. Low voltage the lower compartment and high voltage the upper compartment.

The compartments are open to the left to access the high and low voltage plugs that are coming from the exhaust air blower and isolation dampers (if equipped).

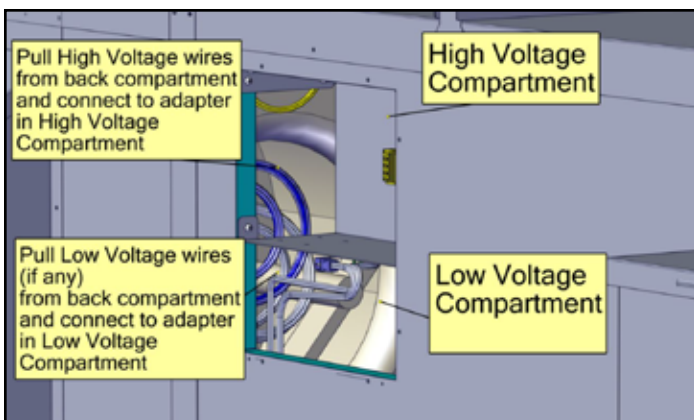

Reach through the back left side of the compartments and into the rear module. Guide the low and high voltage wires in to the front module compartments.

In the front of the compartments there are high and low voltage receptacles.

Plug the high voltage plug on the end of the wires from the rear module into the din rail mounted, high voltage receptacle.

If equipped with either or both OA and EA isolation dampers, plug the low voltage plug(s) that are on the end of the wires from the rear module in to the corresponding low voltage receptacle(s). NOTE: Insure the proper isolation damper plugs from the rear module are matched up to the proper isolation damper receptacles in the front module (See labels of OA and EA on both the plugs and receptacles)

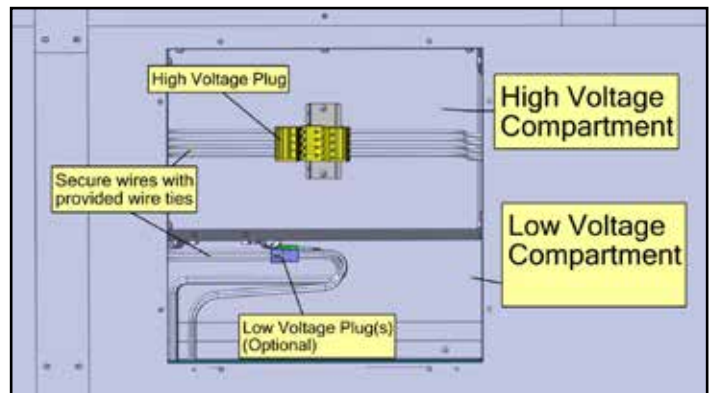

In both compartments secure excess wire with the wire ties located in each compartment.

Replace access cover by sliding the top of the cover underneath of the roof pan and replace screws.

Caulk the sides and bottom of access panel. (Caulk supplied)

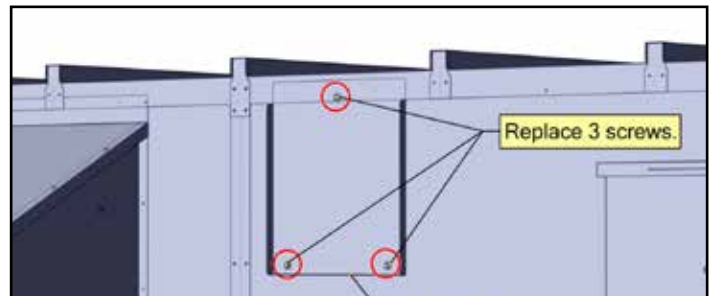

⚠ WARNING

Danger of Electrical Shock unless all internal wiring connections must be made before power is connected to the Unit.

POWER SUPPLY WIRING FOR ALL UNITS

⚠WARNING

Danger of Electrical Shock when servicing an installed unit.

ALWAYS DISCONNECT POWER SOURCE BEFORE SERVICING!
More than one disconnect switch may be required.

Proper Wiring Size Selection and Wiring Installation are the Responsibility of the Electrical Contractor.

The required Electrical Power Supply Voltage, Phase, Motor FLA, MCA and MOPD are marked on the Unit Label (located near electrical box). The complete Unit Model Number and Serial number are found in the lower left corner of the Unit Label.

MINIMUM SUPPLY WIRE RATINGS & REQUIREMENTS

Use Minimum Circuit Ampacity (MCA) rating on the Unit Nameplate as the basis for wiring sizing.

Wire insulation must have minimum 75°C rating.

Wire insulation must have minimum 600V rating.

⚠WARNING

Follow all applicable safety codes, such as NEC or CSA C22.1 Canadian Electric Code part 1!

Electrical Options are identified on the Unit Label (located near electrical box). Find the complete Unit Model Number in the lower left corner of the Unit Label.

POWER SUPPLY CONNECTION LOCATION

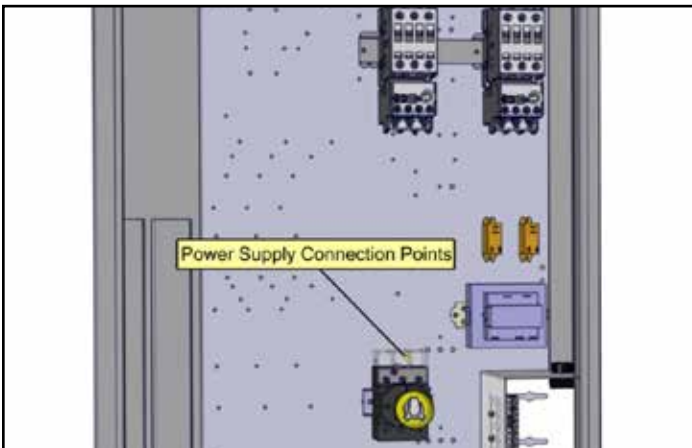

DISCONNECT SWITCH SPECIFICATIONS

LE-series Units are provided with a Disconnect Switch integrated with the Unit Electrical Box access cover. The Unit E-Box Cover cannot be opened without turning this Disconnect Switch to the “OFF” position.

After the E-Box Cover is opened and removed, the Disconnect Switch can be switched back to the “ON” position for trouble-shooting purposes. The Disconnect Switch must be returned to the “OFF” position in order to re-install the E-Box Cover.

NOTE: Local codes may require installation of an additional Disconnect Switch.

POWER SUPPLY:	208-230VAC 3Ø	460VAC 3Ø	575VAC 3Ø	208-230VAC 1Ø
MAX RATED VOLTAGE:	600VAC			
AMPS:	125	63	63	63
HORSE POWER:	20	25	30	7-1/2
MAXIMUM WIRE SIZE:	1/0 AWG	6 AWG	6 AWG	6 AWG
LOAD-SIDE TERMINAL TIGHTENING TORQUE	15 in. • lbs			

⚠WARNING

Even when Disconnect Switch is in the OFF position, Voltage will still be available at the L1, L2 and L# terminals unless power has been disconnected at an upstream location.

⚠WARNING

Re-install the finger-safe guard after connecting the power supply conductors to the L1, L2 & L3 on the Disconnect Switch

FOR THE ELECTRICIAN

BASIC UNIT OPERATION CHECK

Once the main power supply is connected to the Unit, the electrical contractor may want to confirm that the unit is operational.

NOTE: it is assumed below that no external control or system is connected to the Unit at this point.

1. Start with the branch circuit supply to the Unit locked OUT at the fuse box, and Disconnect Switch in the OFF position, with E-Box Cover removed.
2. Confirm correct voltage and phase is corrected to line side of disconnect in Unit E-Box.
3. Confirm that internal wiring from the Unit E-Box to the Exhaust Air Blower is complete. If not, see page 8 for connection instructions.
4. IF optional Exhaust Air or Outside Air Dampers are provided, confirm that internal wiring from the Unit E-Box to the Damper Actuators has been connected. If not, see page 9 for connection instructions.
5. Confirm Overload Relays on the Motor Starters are set correctly.
6. Shut front and rear doors to Unit.
7. At the low-voltage terminals, install a jumper between terminals 2 & 3. Install jumpers between terminals 1 and 4, and between 4 and 5. This will call for unit operation as soon as power is supplied to the unit. Note: In units with 2 VFDs and no dampers, jumpers need to be installed on VFDs's low voltage terminal instead of the electrical box low voltage terminal strip.
8. OPTIONAL FOR MAXIMUM SAFETY - re-install E-Box Cover. If the unit has any VFDs, leave the keypads access cover off.
9. Turn on the branch circuit supply power at the fuse box.

UNIT WITH ONE OR TWO VFDs - SKIP TO STEP 11

10. (MOTOR STARTER UNITS) Turn the Disconnect Switch to the ON position.
 - a. UNITS WITHOUT DAMPERS - both motors should start immediately.
 - b. UNITS with Dampers - dampers should start opening. After about 30 seconds the Damper Actuator end switches will engage and call on the appropriate Motor Starter to engage, and the controlled motor should start.
 - c. SKIP TO STEP 12.
11. (VFD UNITS) Turn the Disconnect Switch to the ON position.
 - a. UNITS WITHOUT DAMPERS:
 - i. If there is only one VFD, the Motor that is not controlled by a VFD should start immediately.
 - ii. To start the motor(s) controlled by VFD(s):
 1. wait for the keypad display(s) to appear.
 2. For each keypad, press the HAND button (see illustration).
 - Motor should start running at a low speed.
 3. Use the UP/DOWN Buttons to set motor speed as desired. Confirm the motors amps are no greater than the motor FLA as listed on the unit nameplate.
 4. Continue to STEP 12
 - b. UNITS with Dampers - the dampers should start opening. After about 30 seconds the Damper Actuator end switches will engage. SKIP BACK TO STEP 11.a.i, above.
12. Turn Disconnect Switch to the OFF position. Disconnect jumper from terminal 1, but otherwise leave the jumpers in place for the convenience of following contractors.
13. Leave unit with E-Box Cover installed.
14. Lock-out and tag-out the Branch Circuit Supply power to the Unit.



FOR THE CONTROL CONTRACTOR

⚠ WARNING

Danger of Electrical Shock when servicing an installed unit.
ALWAYS DISCONNECT POWER SOURCE BEFORE SERVICING!
 More than one disconnect switch may be required.
 Proper Wiring Size Selection and Wiring Installation are the Responsibility of the Electrical Contractor.

ON-BOARD 24VAC CLASS 2 POWER SUPPLY

This ERV is provided with a Class II 24VAC power supply system that operates the unit's contactor(s) for EV450 and HE1X. The ERV's 24VAC Power Supply can also be used to power the externally installed controls system: up to 8VA of power is available.

The unit's power supply system includes isolation relay(s) so you can use external controls whose contact ratings are as low as 50mA (1.2VA). Also, it is possible to operate the isolation relays with 24VAC power from an external source (with proper wiring connections).

A built-in circuit-breaker prevents damage to the transformer and other low-voltage components in the event of a short-circuit or overload. In extreme cases, the transformer itself is designed to fail safely.

CAUTION

1. Connect only to components intended for use with 24VAC power.
2. Do not interconnect the unit's Class 2 power supply with an external Class 2 power supply.
3. Do not undersize the low-voltage wires connected to this device. Observe the wire length and gauge limits indicated in this manual.
4. Do not overload this unit's 24VAC power supply system. Confirm that the power requirements of devices you connect to this power supply system do not exceed 8VA in total.
5. If an external source of 24VAC power is used to control the unit, consult the wiring schematics and connect the external power only to the specified terminals in order to avoid damaging the unit or external controls. Connect only CLASS II power to the control terminals of this unit.
6. Unit is not equipped to receive analog signals (such as 1-10vdc or 4-20mA). Unless it is provided in VFDs.
7. Unit is not equipped to communicate directly with Building Management Systems (such as BACNET, LONWORKS, etc.). However, the unit can be controlled by powered or nonpowered contacts operated by any kind of control system.
8. Units equipped with VFDs can communicate with BACnet.

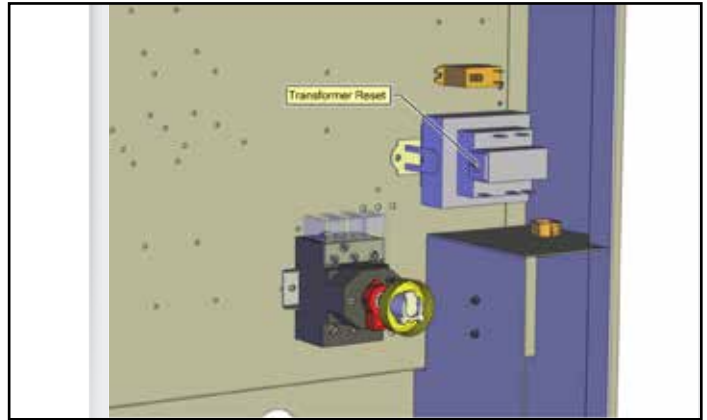

Transformer Specifications

- Nominal Output Voltage under load: 24VAC
- Typical Output Voltage at no load: 29-31V
- Minimum contact rating for connected control device: (50mA (1.2VA))
- Circuit Breaker Trip Point: 3A

Limits of Class 2 Power Output

If limits on wire gauge and length are observed, you may connect control devices that draw up to 8VA to the blue and red wires.

More than one device can be connected as long as total steady-state load does not exceed 8VA.

This ERV is provided with a Class II 24VAC power supply system that operates the unit's contactor(s) for EV450 and HE1X. The ERV's 24VAC Power Supply can also be used to power the externally installed controls system: up to 8VA of power is available.

OBSERVE THESE LIMITS TO WIRE LENGTH AND GAUGE, to ensure reliable operation of the control system.

Wire Gauge	#22	#20	#18	#16	#14	#12
Circuit Length (ft)	100'	150'	250'	400'	700'	1000'

"Circuit Length" is the distance of the wire route from the ERV to the Control Device.

How to Reset the 24VAC Circuit Breaker

If the transformer is subjected to an excessive load or a short circuit, the circuit breaker will trip to prevent the failure of the transformer. When it trips the circuit breaker's button pops up.

Shut off the primary-side power to the unit, and remove the excessive load or the short. The circuit breaker can be reset about fifteen seconds after it trips by pressing in the button.

CAUTION

UNITS WITH 230VAC POWER SUPPLY:

Unit is shipped with transformer set for 208VAC power supply. For 230VAC, move the black primary-side lead from the transformer's "208V" terminal to the transformer's "230V" terminal.

Do not move the black primary-side lead that is connected to the transformer's "COM" terminal.

FOR THE CONTROL CONTRACTOR

MOTOR PROTECTION: UNITS EQUIPPED WITH MOTOR STARTERS

When the unit is not specified with optional Variable Frequency Drives (VFDs), it is supplied with IEC-style motor starters to operate the motors and to protect them against overload.

IEC-style motor starters use Overload Relays to detect excessive current and interrupt the control circuit that engages the motor's contactors.

The Overload Relays are sized to Full Load Amp (FLA) rating of the protected motor. The Overload Relays can be adjusted to trip (interrupt the control circuit) at a specific setting within a range. Overload Relays should initially be set at the FLA rating of the motor (see Unit Rating Label). If necessary to prevent nuisance tripping at start-up, the Relays can be adjusted to trip no higher than 115% of the motor's FLA rating.

For safest operation, the overload relays should also be used in manual reset mode with trip test capability.

NOTE: As factory-wired, if one blower motor is shut down due to overload by its Motor Starter, the other motor will also be shut down.

NOTE: Terminals 96 & 97 of the Overload Relays and terminals 14 & 13 of the Contactors are normally-open dry contacts that may be used to signal that the contactors are closed and/or that the Overload Relays have tripped.

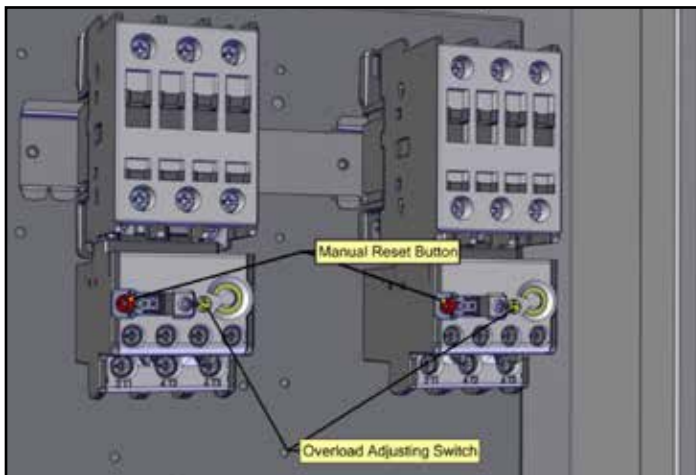

MOTOR PROTECTION: UNITS EQUIPPED WITH VARIABLE FREQUENCY DRIVES (VFDs)

SEE SEPARATE SUPPLEMENTS

In units provided with VFD, the motor overload protection function is provided by the VFD.

NOTE: Some units are equipped with a single VFD, which controls only one of the motors.

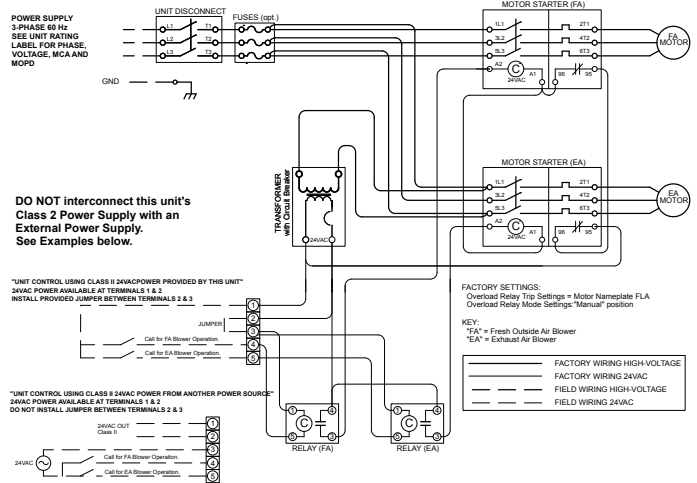

EXTERNAL CONTROL CONNECTIONS

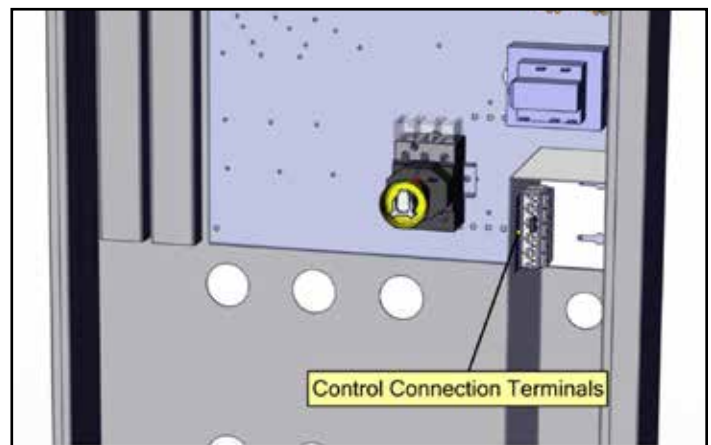

NOTE: The simplified schematics below show only the relevant portions of the low-voltage control circuit in the ERV unit and representational external control approaches. See the complete unit schematics elsewhere in this manual.

A. Single 2-wire Control, unpowered: Use schematic below if the control requires no power from the unit to operate and acts like a simple on/off switch. The control must not supply any power to the ERV unit. Install jumper (provided) between terminals 2 & 3. Connect the control's contacts to terminals 1 & 4 to operate the ERV's Isolation Relay for OA/ FA Blower. Install jumper (provided) between terminals 4 & 5 to operate the ERV's Isolation Relay for the RA/EA Blower.

A SWITCH OR NON-POWERED CONTROL USING UNIT'S 24VAC POWER SUPPLY

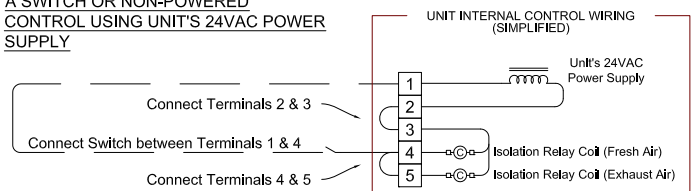

B. Single 2-wire Control on separate Power Supply, no power present at Control Output: Wire as shown for the Single 2-wire control (A. above).

CAUTION

Make sure the control provides no voltage or current at its output terminals.

FOR THE CONTROL CONTRACTOR

C. Control Sending 24VAC “On” Signal (from an external power source) to ERV: Make sure jumper is NOT installed between Terminals 2 & 3. Now you safely can apply 24VAC to the Terminals 3 & 4 to operate the ERV’s Isolation Relay for OA/FA Blower. Install jumper (provided) between terminals 4 & 5 to operate the ERV’s Isolation Relay for the RA/EA Blower.

24VAC FROM AN EXTERNAL SOURCE

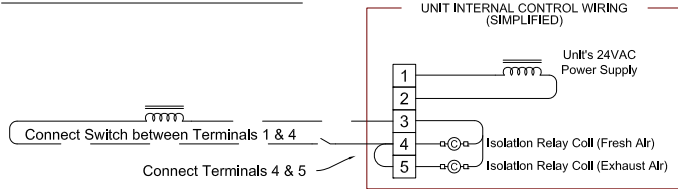

CAUTION

Supply only 24VAC (not VDC) from a Class II Power Source.

BASIC OPERATING SEQUENCES

Operating sequences are different, depending on whether the unit is:

Controlled for simultaneous blower operation, as in A-D, above, or controlled for independent blower operation, as in E-F, above;

Is factory-provided with OA Damper, EA Damper, or both;

Is factory-provided with VFD control of one or both motors.

Simultaneous or Independent Blower Operation:

When set up for Simultaneous Blower Operation, both blowers should respond to a call for unit operation at the same time, unless only one of the blowers is controlled by a VFD or unless only one of the blowers is in an airstream with a Damper.

When set up for Independent Blower Operation, each blower will follow an independent operating sequence.

Dampers

When one or both of the airstreams are factory-provided with Dampers, the control sequence for that airstream’s blower is as follows:

1. External control calls for operation. Damper immediately starts to open.
2. After about 30 seconds, damper is open fully and the Damper Actuator End Switch closes.
3. The Damper Actuator End Switch completes a low-voltage circuit that turns on the appropriate Blower, either through the blower’s Motor Starter, or through the blower’s VFD.
4. If that Blower is controlled by a Motor Starter, it starts immediately.

Variable Frequency Drives (VFDs)

When one or both of the blowers are factory-provided with VFDs, the response of the Blower Motor depends on the VFD’s settings and connected control signal.

Typically, the VFD will be connected to an control device which provides a variable, analog signal (0-10VDC or 4-20mA) as an input to the VFD. The VFD must be set to respond to this input with appropriate Motor operating speeds.

Alternately, the VFD might be controlled by a Time Clock, which defines different operating periods (e.g. “occupied” and “unoccupied”). Each period calls on one of up to three different VFD Presets to provide different Motor speeds in different operating periods.

It is beyond the scope of this document to detail setup of VFDs and external control systems. Please see separate VFD MANUAL ABB.

CAUTION

Supply only 24VAC (not VDC) from a Class II Power Source.

D. Control operating on Unit’s 24VAC Power Supply: 24VAC power is available at the Terminals 1 & 2. CAUTION: external control system should not draw more than 8VA. Install jumper (provided) between terminals 2 & 3. Connect the switched output of the Control to Terminal 4 to operate the ERV’s Isolation Relay for OA/FA Blower. Install jumper (provided) between terminals 4 & 5 to operate the ERV’s Isolation Relay for the RA/EA Blower.

AN EXTERNAL CONTROL USING UNIT'S 24VAC POWER SUPPLY

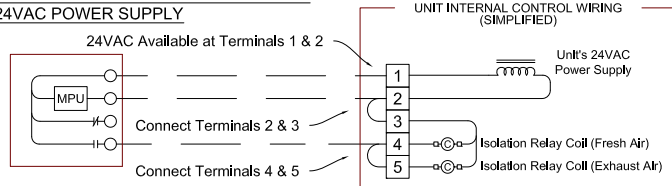

E. Control System with 2 Non-powered Relay Contacts: Use this schematic if the external control system provides no voltage or current at its output contacts. Install jumper (provided) between terminals 2 & 3. Connect one side of each of the output contacts to Terminal 1. Connect the other side of the output contact to control the FA Blower to Terminal 4, and the output contacts to control the EA Blower to Terminal 5.

A SWITCH OR NON-POWERED CONTROL USING UNIT'S 24VAC POWER SUPPLY

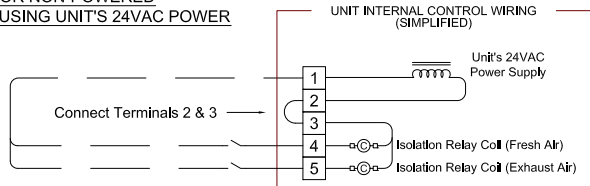

F. Control System Sending two 24VAC “On” Signals from an external power source: Make sure the jumper is NOT installed between Terminals 2 & 3. Now you safely can apply one of the 24VAC signals to Terminals 3 & 4 to operate the ERV’s isolation relay for the Fresh Air Blower. Apply the second 24VAC signal to Terminals 3 & 5 to operate the ERV’s isolation relay for the Exhaust Blower (make sure the polarity of each wire connected to Terminal 3 is the same).

TWO EXTERNAL RELAY CONTACTS SUPPLYING 24VAC FROM AN EXTERNAL SOURCE

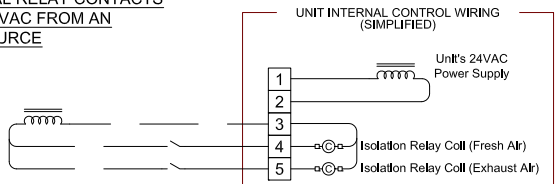

TEST AND BALANCE

LE-8X-RT AIRFLOW PERFORMANCE*

Motor HP	Blower RPM	Turns Open	External Static Pressure (in.w.g.)																	
			0.00		0.25		0.50		0.75		1.00		1.25		1.50		1.75		2.00	
			CFM	BHP	CFM	BHP	CFM	BHP	CFM	BHP	CFM	BHP	CFM	BHP	CFM	BHP	CFM	BHP	CFM	BHP
3.0 HP	632	6	4670	1.6	3390	1.5														
	673	5	5140	1.8	3960	1.6	2620	1.4												
	714	4	5590	2.1	4500	1.8	3260	1.5												
	755	3	6030	2.4	5020	2.1	3880	1.8	2540	1.4										
	796	2	6460	2.8	5520	2.5	4470	2.1	3250	1.7										
	837	1			6010	2.9	5040	2.5	3920	2.1	2570	1.6								
5.0 HP	773	6	6220	2.5	5240	2.2	4140	1.9	2850	1.6	1240	1.1								
	815	5	6890	3.2	6010	2.9	5040	2.5	3920	2.1	2570	1.6								
	857	4	7090	3.4	6250	3.1	5310	2.8	4240	2.4	2960	1.9								
	898	3	7530	4.0	6740	3.6	5870	3.3	4880	2.9	3730	2.4	2250	1.7						
	940	2	7970	4.6	7230	4.3	6420	3.9	5520	3.5	4470	3.0	3180	2.4						
	982	1			7730	4.9	6980	4.5	6140	4.1	5180	3.6	4050	3.1	2550	2.3				
7.5 HP	1000	6	8630	5.6	7950	5.2	7210	4.8	6400	4.4	5480	3.9	4400	3.4	3010	2.7				
	1041	5	8800	6.2	8450	6.0	7760	5.6	7000	5.2	6160	4.7	5180	4.2	3980	3.5	2270	2.6		
	1082	4			8800	6.8	8310	6.4	7600	6.0	6820	5.5	5930	5.0	4880	4.4	3510	3.6		
	1122	3					8800	7.2	8190	6.8	7460	6.4	6640	5.9	5700	5.3	4540	4.6	2870	3.6
	1163	2							8500	7.5	8120	7.3	7370	6.8	6510	6.3	5500	5.6	4200	4.8
	1204	1													7310	7.3	6420	6.7	5320	6.0

* Performance Ratings assume standard-equipment 2" MERV-8 filters in clean condition.

Operation in this zone will likely exceed FLA limits. Operation in this zone outside of core airflow limits.

TABLE: CLEAN-FILTER PRESSURE DROP (in.w.g.)

Airflow (CFM)	2000	2500	3000	3500	4000	4500	5000	5500	6000	6500	7000	7500	8000	8500
2" MERV 8	0.03	0.04	0.05	0.06	0.07	0.08	0.09	0.10	0.11	0.13	0.14	0.15	0.16	0.17
2" MERV 13	0.04	0.06	0.07	0.09	0.10	0.11	0.13	0.15	0.16	0.18	0.19	0.21	0.23	0.24
4" MERV 8	0.01	0.02	0.02	0.03	0.03	0.04	0.05	0.06	0.07	0.08	0.08	0.09	0.10	0.11
4" MERV 13	0.02	0.02	0.03	0.04	0.05	0.06	0.07	0.09	0.10	0.11	0.12	0.14	0.15	0.17

NOTE: Pressure drop of clean 2" MERV-8 Filters is included in the Unit Performance Ratings Table.

FILTERS

(16) 20" x 25" x 2" or 4" (nominal) pleated filters
 Actual size: 19.5" x 24.5" x 1.75" or 3.75"
 Unit shipped with MERV-8 Filters.
 Optional MERV-13 Filters are available.
 Minimum recommended effectiveness: MERV-6
 Filter Rack can be adjusted to accept 4" filters by loosening nuts and bolts and sliding filter flanges outward to the ends of the slots. Re-tighten bolt and nuts.

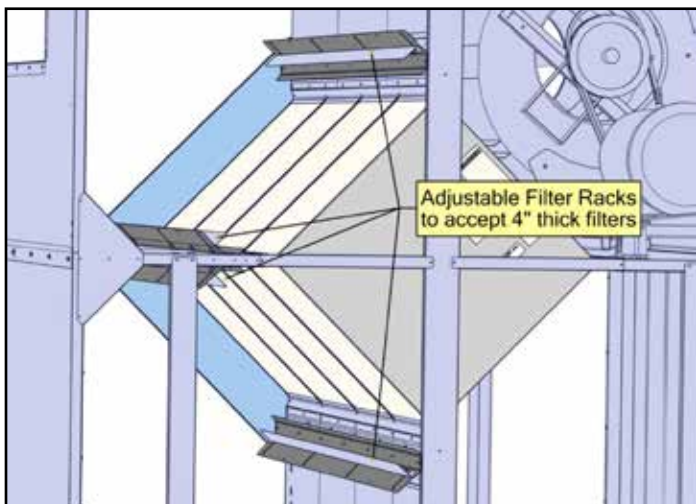

MEASURING AIRFLOW

Equipment Required

A magnehelic gauge or other device capable of measuring 0 to 1.5 in. water of differential pressure.

2 pieces of natural rubber latex tubing, 1/8" ID, 1/16" Wall works the best. NOTE: Be sure to remove cap from pressure port before inserting tubing. Insure tubing is well seated in pressure ports. NOTE: The tubing should extend in the pressure port approx. 1 inch.

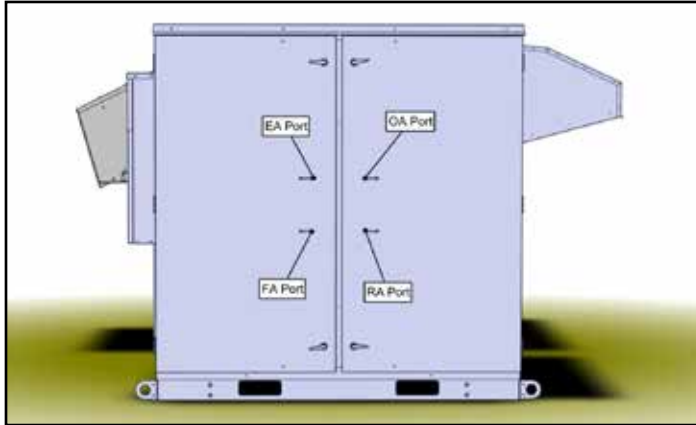

Procedure

The individual differential static pressures (DSP) can be measured using the installed pressure ports located in the front of the units core access doors. NOTE: These ports have been carefully located on the unit as to give you the most accurate airflow measurement. NOTE: Do not relocate pressure ports.

To read SCFM of Fresh Air (FA) install the "high" pressure side (+) of your measuring device to the Outside Air (OA) port and the "low" pressure side (-) to the Fresh Air (FA) port.

To read SCFM of Room Air (RA) install the "high" pressure side (+) of your measuring device to the Room Air (RA) port and the "low" pressure side (-) to the Exhaust Air (EA) port.

Use the reading displayed on your measurement device to cross reference the CFM output using the conversion chart.

NOTE: Be sure to replace cap into pressure port when air flow measuring is completed.

LE-8X-RT	Differential Pressure Measured Across Core								
	0.2	0.3	0.4	0.5	0.6	0.7	0.8	0.9	1.0
FA Airflow (CFM)	1790	2830	3820	4750	5630	6460	7230	7950	8610
RA Airflow (CFM)	1850	2880	3900	4910	5890	6860	7820	8750	9670

SHEAVE ADJUSTMENT AND BELT TENSIONING

The variable sheaves provided on the blower motors can be adjusted to drive the blowers at one of 11 speeds, as shown in the table below.

TABLE of SHEAVE ADJUSTMENT													
Motor HP	Blower Speeds Available by Sheave Adjustment											Motor Sheave	Blower Sheave
3.0 HP	837	816	796	775	755	734	714	693	673	653	633	1VP44	BC90
5.0 HP	982	961	940	919	898	877	857	835	815	793	773	2VP50	D4880
7.5 HP	1204	1183	1163	1142	1122	1101	1082	1061	1041	1020	1000	2VP62	D4900
<i>Variable Sheaves can be adjusted by half-turns.</i>													
<i>Use only BX-type cogged drive belts</i>													

NOTE: the Unit is shipped with Sheaves adjusted to less than maximum speed, so that unit will not over-amp if it is operated while not connected to ductwork.

To Adjust Variable Sheaves

First, relieve tension on belt and remove it:

Loosen nuts on top of motor mount plate at the jacking screws (see illustration).

Use the nuts below the motor mount plate to lift the motor up so that the belt can be removed. Alternately, carefully lift the motor mount plate with a lever.

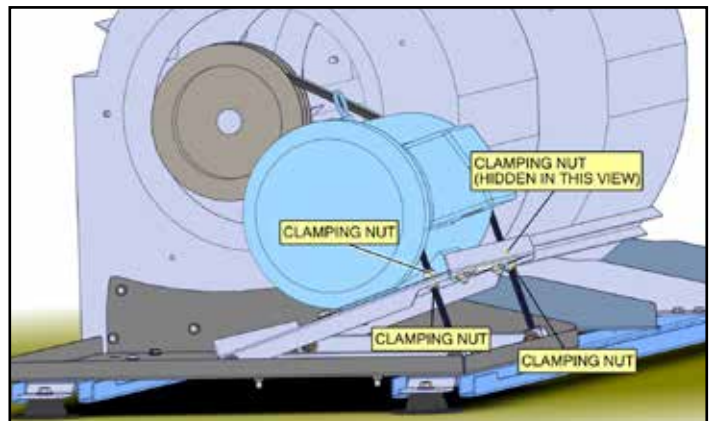

SHEAVE ADJUSTMENT AND BELT TENSIONING

To Adjust Variable Sheaves

Second, loosen the visible allen screw(s) on the variable sheaves until the key can be removed.

(Two-belt sheaves are used with 5 and 7.5HP motors, and two allen screws need to be loosened.)

Spin the sheave in (to increase blower speed) or out (to decrease speed).

Sheaves can be adjusted by half-turns only.

With double sheaves, be sure to set both sheaves in the same position.

After adjusting sheave, re-install the key, and tighten down the allen screw to a torque setting of 125 - 150 in. •lbs.

NOTE: with single-belt sheaves, it may be necessary to change the position of the sheave on the blower shaft to ensure the centerlines of the sheaves are aligned. This is not required with the double-belt sheaves.

Third, re-install belt(s) and adjust motor mount plate to properly align the sheaves and to tension the belt(s):

See belt tension table below.

In addition to achieving the proper belt tension, it is important that the motor shaft be parallel to the blower shaft. It may be necessary to pull DOWN on the jacking screw nearest the blower, and push UP on the other jacking screw.

Once the belt is properly tensioned and aligned, securely clamp the nuts on the jacking screws above and below the motor mount plate (see illustration).

Properly tensioned belt will deflect 1/8" when pressed at the center point with the following force:

ALL HP BLOWERS - 11 pounds (initial tensioning in the factory)

It is recommended to re-tension belt after 24-48 hours of operation.

ALL HP BLOWERS - 7-9 pounds will deflect 0.125"

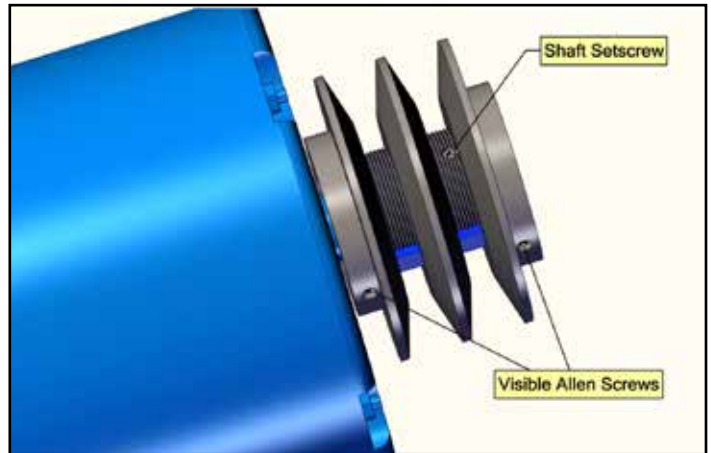
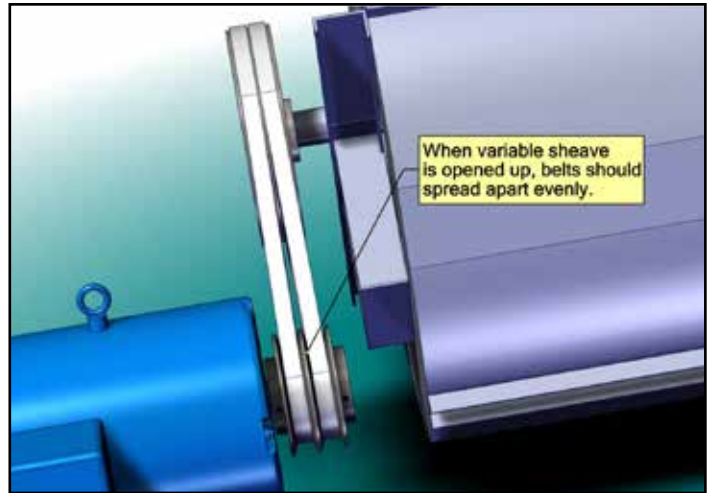

CAUTION

Failure to follow start-up procedures may cause early equipment failure!

CAUTION

Improperly aligned sheaves can cause early belt, sheave or bearing failure.

NOTE: Possible to replace Variable Sheaves with fixed sheaves.

With two-belt Variable Sheaves, at some settings the distance between the belts at the Variable Sheave is different than it is at the Fixed Sheave. This results in slight mis-alignment of the belts; this should be evenly split between the two belts. The cogged BX-type belts provided can handle this mis-alignment up to 2°, and the drive system is designed to allow for alignment within these limits. Substitution of fixed sheaves of appropriate diameter and belt spacing can allow this minor mis-alignment to be eliminated, which may extend belt life.

NOTE - SHEAVE SETTINGS FOR UNITS WITH VFDs

The recommended final sheave setting for units with VFDs is zero turns open, i.e., the maximum speed setting. Control blower speed by adjusting the VFDs output frequency. However, if at the VFDs maximum operating frequency, which generally should be limited to 60 Hz, the motors overload, adjust the variable sheaves to prevent this.

START-UP AND CHECK-OUT PROCEDURES

Before placing unit in service:

Check belt tension (see Blower Maintenance Information)

Inspect blower (see Blower Maintenance Information)

As part of first start-up:

Install clean filters if the unit has been operated during the construction phase.

Check running amps of each motor. Adjust if needed to maintain current below the motor FLA.

Units with Motor Starters: Confirm the motor starter overload relays are properly set.

Units with VFDs: Confirm the maximum power output parameters are properly set. See supplemental VFD Manual.

Confirm the Unit operating sequence in response to control inputs is as specified by the project engineer or commissioning documents.

SERVICE PARTS

The service and replacement parts shown are available from RenewAire from your distributor. When ordering parts, be sure to provide the SERIAL NUMBER and CONFIGURATION CODE of the unit; these are found on the Unit's Electrical Rating Label.

EXAMPLE SERIAL NUMBER: A141234

Character 1: Letter ranging from A to L, representing month of manufacture

Characters 2-3: Two digits representing year of manufacture

Characters 4-7: Four digits making the serial number unique to one unit.

EXAMPLE CONFIGURATION CODE: LE-8XJRTVNS35XX---ANT-A-L

For complete explanation of configuration code, see page 3.

When blower, motor, VFD or damper parts are needed, be sure to indicate for which airstream (Fresh Air or Exhaust Air) the parts are needed.

Some replacement parts are covered by a multi-year warranty. See separate warranty document.

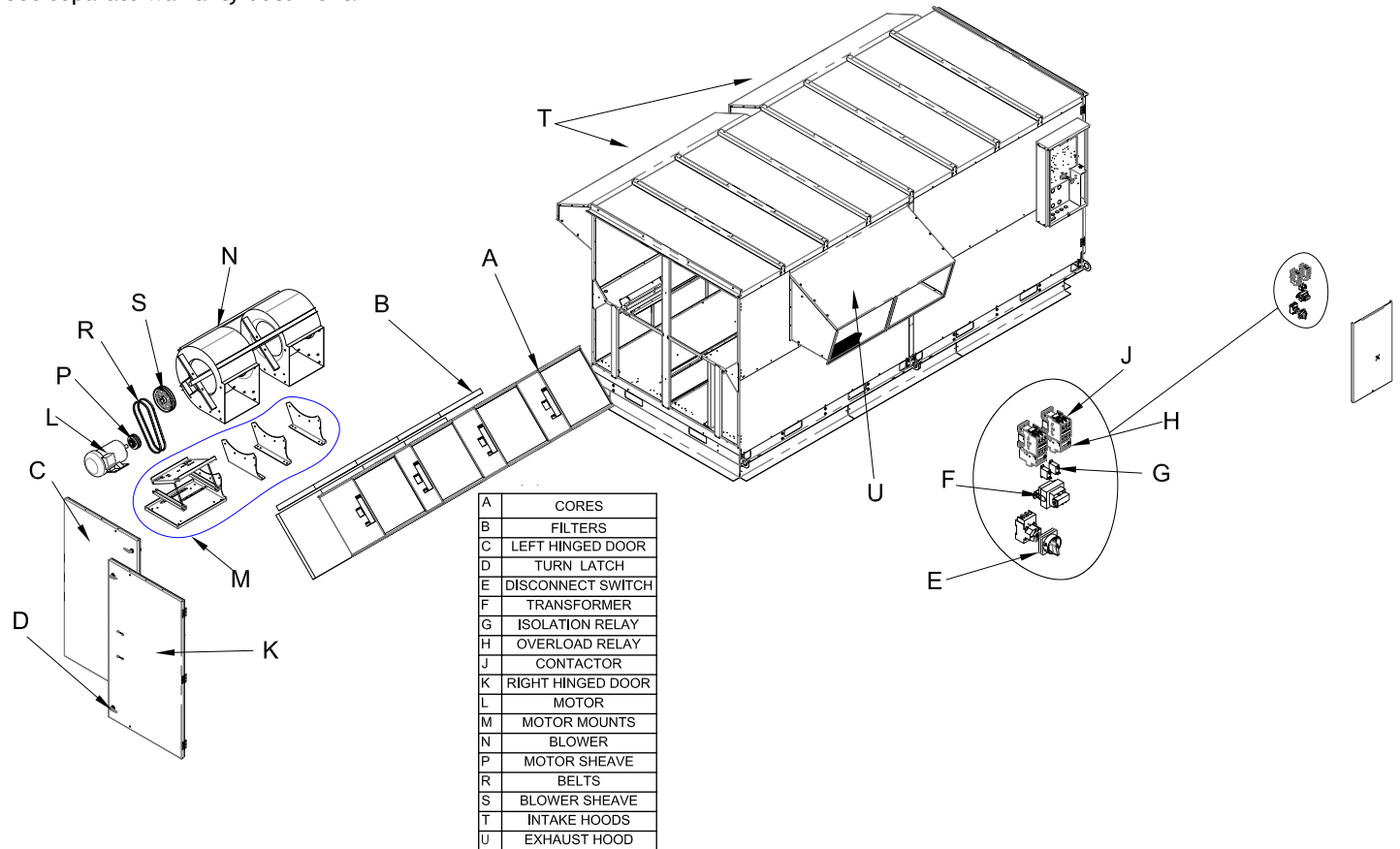

MAINTENANCE

SUMMARY MAINTENANCE REQUIREMENTS

- Change Filters
- Inspect Blower
- Tension Blower Belt
- General Cleaning and Inspection
- Bearing Lubrication
- Clean Energy Exchange Cores

⚠ WARNING

Danger of injury from un-guarded drive belts in unit.

Disconnect power to unit before opening door.

Danger of injury if unit starts unexpectedly. Switch power off at service disconnect. Lock-out/tag-out the disconnect.

CHANGING THE FILTERS

- Inspect and/or replace filters every two or three months when the unit is in regular use, or as needed.
- Turn off unit completely! Lock-out and tag-out the unit disconnect switch.
- Open the Door. The door is secured with turn-type latches, plus one Phillips-head securing screw. Keep the securing screw.
- A long wire hook is provided inside one of the filter racks to help with filter removal. You will need to use both sets of doors to change the filters.
- Use the hook to remove all (16) filters and dispose of them. Replace all (16) filters. Return the hook to a convenient location inside the Unit.
- Close door; reinstall securing screw. NOTE: Always replace securing screw when reinstalling door.

CAUTION

Filters must be used or the energy exchange core will become blocked by dust and the unit will not do its job. In extreme cases components may be damaged.

Filter Specifications:

(16) 20" x 25" x 2" or 4" (nominal) pleated filters
Actual size: 19.5" x 24.5" x 1.75" or 3.75"
Unit shipped with MERV-8 Filters.
Optional MERV-13 Filters are available.
Minimum recommended effectiveness: MERV-6

BLOWER INSPECTION

- Inspect Blowers every time you change the filters.
- Confirm bearings are still secure to blower shaft. It should not be possible to move the blower shaft back and forth along its length.
- Confirm blower wheel is not rubbing against the blower inlet or housing.

CHECK BLOWER BELT TENSION

- Check belt tension every time you change the filters.
- Inspect belt(s) for cracking or uneven wear. Uneven wear may indicate that sheaves are improperly aligned.
- See section SHEAVE ALIGNMENT AND BELT TENSIONING (page 16) for additional details

CAUTION

Incorrect Belt Tension will damage this blower!

GENERAL CLEANING AND INSPECTION

- Perform general cleaning and inspection when changing filters.
- Remove dust from blower wheels periodically.
- Remove paper, leaves, etc. from inlet and outlet screens.
- Inspect for insect nests.

BEARING LUBRICATION

The blowers in this unit are equipped with permanently-lubricated bearings; the grease fittings are used only for initial lubrication at the factory. NOTE: do not attempt to lubricate the blower bearings.

If the motors used in this ERV are equipped with grease fittings, motors must be lubricated as part of routine maintenance. Use Exxon Polyrex or equivalent at 2500 operating hour intervals.

See more specific Installation and Operation Manual for additional Assembly, Start-Up, Commissioning and Maintenance supplied with the unit and Manuals at www.renewaire.com.

MAINTENANCE

TO CLEAN THE ENERGY EXCHANGE CORE

Clean the core annually.

- Remove the filters.
- Vacuum the exposed faces of the energy exchange core with a soft brush.
- Vacuum out dust from the rest of the unit case.
- Install new filters.

CAUTION

Do not wash the energy exchange core.

Keep it away from water or fire to avoid damaging it. Always handle the core carefully.

TO REMOVE ENERGY EXCHANGE CORES FOR ACCESS TO OTHER COMPONENTS

CAUTION

It is not recommended to remove the energy exchange cores unless there is no other way to gain access to other components that require service.

To remove cores (see illustration):

1. Remove cross pieces (retain screws)
2. Remove vertical sealing bar (retain screws).
3. Carefully grasp core(s) by the metal end plate, near the corners. (Or use glass-handling suction cups.) Gently pull out; it may be helpful to wiggle the core slightly so that first one corner, then another advances out of the unit.

CAUTION

The white faces of the core can be damaged. Handle with care.

To re-install the cores:

1. Start the bottom corner flange of the core about an inch into the receiver in the unit, then start one side flange in to its receiver.
2. Taking care not to drop the core, start the other side flange, and then the top flange.
3. Push core gently and evenly into place, repeat with the next core. Don't compress the end-pan gaskets yet.
4. When the front-most core is in place, place the vertical sealing bar in position. Gently push the front core back until its face aligns properly against the back of the sealing bar.

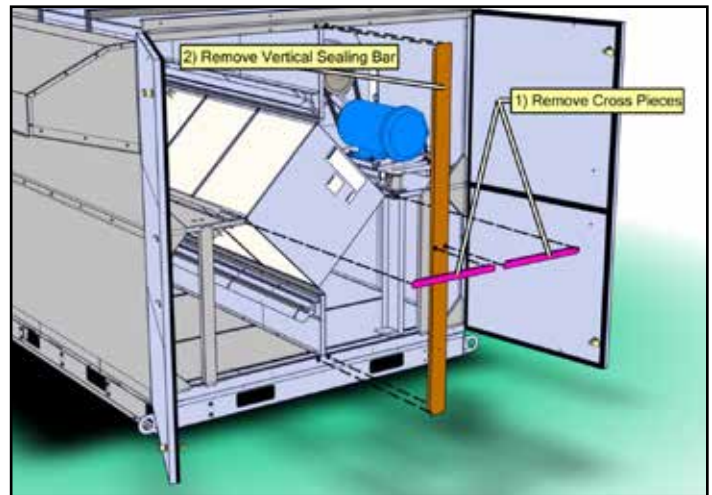

See more specific Installation and Operation Manual for additional Assembly, Start-Up, Commissioning and Maintenance supplied with the unit and Manuals at www.renewaire.com.