

# Unitary Air Handler

DX AND HYDRONIC SERIES

## Installation and Maintenance Manual

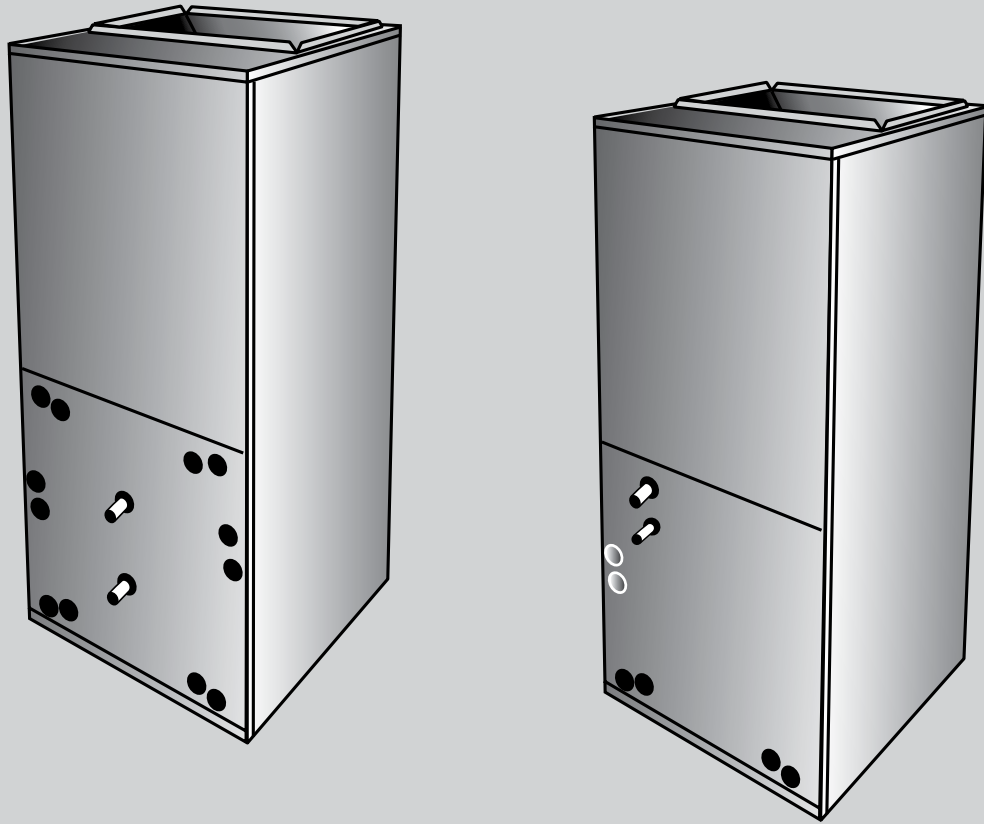

6720220327

Revised 11-11



# BOSCH

**TABLE OF CONTENTS**

Model Nomenclature.....2  
 Physical Data.. 3  
 Dimensional Data.....4  
 General Information.....6  
 Initial Inspection .....6  
 Moving and Storage .....6  
 Safety Considerations.....6  
 Reference.....6  
 Location.....7  
 Installation/Operation Safety Rules .....7  
 Minimum Clearances .....8  
 Arrangement.....8  
 Upflow Application.....8  
 Horizontal Application .....8  
 Downflow Application.....9  
 Downflow Conversion Kit.....10  
 Furnace Installation .....11  
 Electrical Wiring.....11  
 Line Voltage Wiring .....11  
 Field Installed Electric Heater Kits .....12  
 Variable Speed Motor.....13  
 Replacing ECM Motor .....13  
 ECM Interface Board & Thermostat Connections.....14  
 Control Wiring.....15  
 Condensate Drain .....16  
 Duct System.....16  
 Piping.....17  
 DX Refrigerant Piping.....17  
 Water Piping .....18  
 Chilled Water Piping .....18  
 Hot Water Piping .....18  
 Field Installed TXV.....18  
 Check Test and Start Up.....19  
 System Shut Down.....20  
 Periodic Maintenance .....20  
 Connecting Unit Mounted Controller Water-to-Water Unit to HY Air Handler.....20  
 Performance Tables .....22  
 Motor Control Board Settings .....23  
 System Piping Schematics .....24  
 Electrical Data.....25  
 Electrical Diagrams .....26  
 Unit Check-Out Sheet .....31

**MODEL NOMENCLATURE**

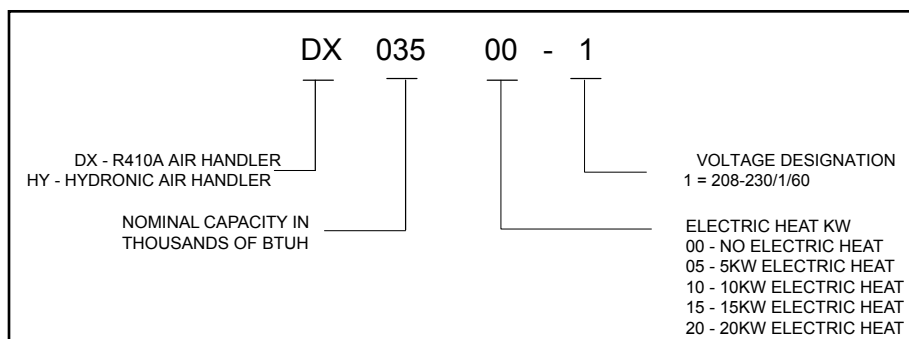

**Table 1: Physical Data**

<b>DX UNITS</b>	<b>DX025</b>	<b>DX035</b>	<b>DX049</b>	<b>DX061</b>	<b>DX071</b>
Nominal Capacity (Tons)	2	3	4	5	6
Refrigerant Type	R410A				
Liquid Line Connection Size (in)	3/8	3/8	3/8	3/8	3/8
Suction Line Connection Size (in)	3/4	3/4	7/8	7/8	7/8
Standard Filter Size	16 x 20 x 2	20 x 20 x 2	20 x 24 x 2	20 x 24 x 2	20 x 24 x 2
Condensate Connection Size (in)	3/4	3/4	3/4	3/4	3/4
Blower Size	9X6	10X7	12X9	12X10	12X10
Blower Motor HP	1/3	1/2	3/4	1	1
Blower Motor Type	ECM Style - Constant CFM/Variable Speed				
Available Electrical (v/p/h)	208-230 / 1 / 60				
Shipping Weight (lbs)	120	145	202	212	217
Installation Weight (lbs)	108	132	170	172	180
	<b>HY025</b>	<b>HY035</b>	<b>HY049</b>	<b>HY061</b>	<b>HY071</b>
Nominal Capacity (Tons)	2	3	4	5	6
Water In Connection Size (in)	7/8	7/8	1-1/8	1-1/8	1-1/8
Standard Filter Size	16 x 20 x 2	20 x 20 x 2	20 x 24 x 2	20 x 24 x 2	20 x 24 x 2
Condensate Connection Size (in)	3/4	3/4	3/4	3/4	3/4
Blower Size	9X6	10X7	12X9	12X10	12X10
Blower Motor HP	1/3	1/2	3/4	1	1
Blower Motor Type	ECM Style - Constant CFM/Variable Speed				
Available Electrical (v/p/h)	208-230 / 1 / 60				
Shipping Weight (lbs)	130	145	215	215	218
Installation Weight (lbs)	110	132	184	184	184

**DIMENSIONAL DATA FOR DX UNITS**

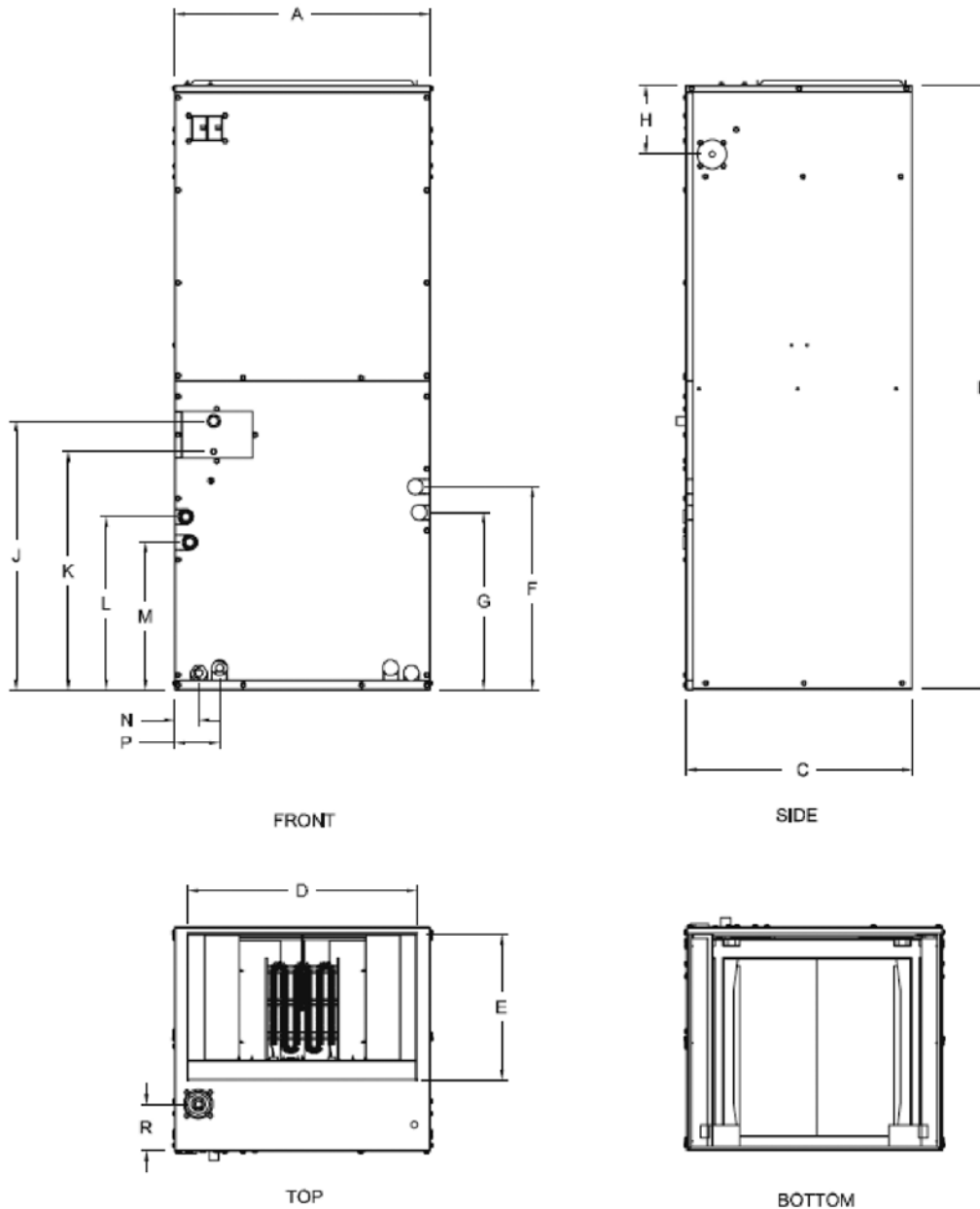

DIMENSIONAL DATA MULTI-POSITION AIR HANDLER COOL ONLY OR ELECTRIC HEAT															
Model	A	B	C	D	E	F	G	H	J	K	L	M	N	P	R
DX025	17.50	43.00	21.00	15.50	12.50	13.50	11.00	6.75	16.75	14.00	11.00	10.75	2.00	1.50	5.00
DX035	21.00	48.00	21.00	19.00	12.50	14.50	13.00	6.75	20.00	17.00	12.75	10.30	2.30	4.35	5.00
DX049	24.50	58.75	21.75	23.35	21.25	19.75	17.25	6.75	26.00	23.00	16.75	14.35	2.30	4.35	4.50
DX061	24.50	58.75	21.75	23.35	21.25	19.75	17.25	6.75	26.00	23.00	16.75	14.35	2.30	4.35	4.50
DX071	24.50	58.75	21.75	23.35	21.25	19.75	17.25	6.75	26.00	23.00	16.75	14.35	2.30	4.35	4.50

**DIMENSIONAL DATA FOR HYDRONIC AIR HANDLERS**

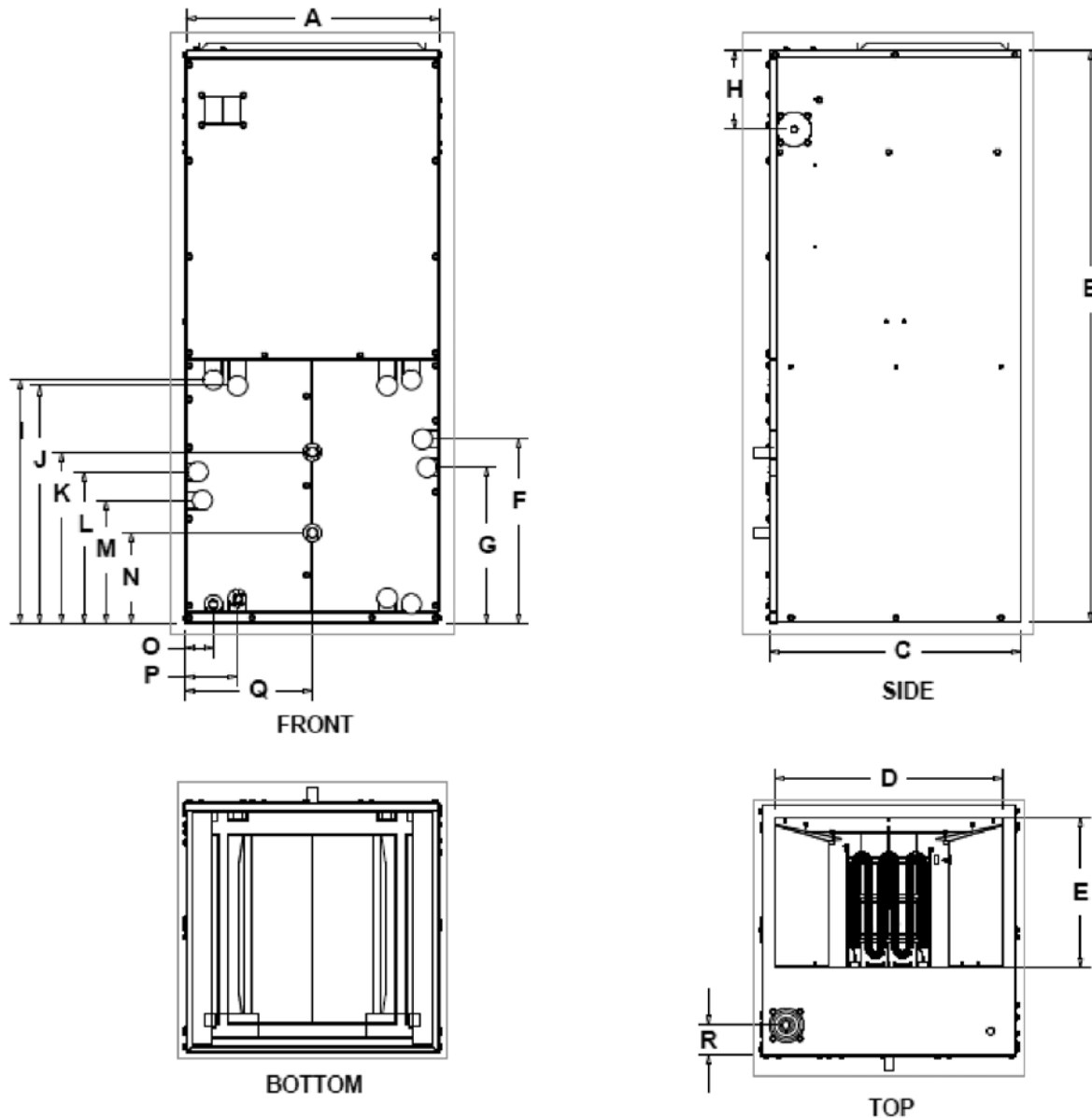

DIMENSIONAL DATA MULTI-POSITION AIR HANDLER HYDRONIC HEAT																		
Model	A	B	C	D	E	F	G	H	I	J	K	L	M	N	O	P	Q	R
HY025	17.50	43.00	21.00	15.50	12.50	13.50	11.00	6.75	16.75	16.25	13.50	10.75	8.25	4.75	2.00	4.00	8.75	2.00
HY035	21.00	48.00	21.00	19.00	12.50	15.50	13.00	6.75	20.25	19.75	14.25	12.75	10.25	7.50	2.25	4.25	10.50	2.50
HY049	24.50	58.75	21.75	19.50	16.25	19.75	17.25	6.75	28.25	27.75	19.75	16.00	13.50	10.25	2.25	4.25	12.50	2.25
HY061	24.50	58.75	21.75	19.50	16.25	19.75	17.25	6.75	28.25	27.75	19.75	16.00	13.50	10.25	2.25	4.25	12.50	2.25
HY071	24.50	58.75	21.75	19.50	16.25	19.75	17.25	6.75	28.25	27.75	19.75	16.00	13.50	10.25	2.25	4.25	12.50	2.25

## GENERAL INFORMATION

This single piece air handler provides the flexibility for installation in any upflow, downflow, or horizontal application. These versatile models may be used with or without electric or hot water heat. The direct drive ECM variable speed motor provides a selection of air volume to match any application.

The unit can be positioned for bottom return air in the upflow position, top return air in the downflow position and end return air in the horizontal position.



See field installed down flow conversion kit installation instructions.

## INITIAL INSPECTION

Be certain to inspect all cartons or crates on each unit as received at the job site before signing the freight bill. Verify that all items have been received and that there are no visible damages; note any shortages or damages on all copies of the freight bill. In the event of damage or shortage, remember that the purchaser is responsible for filing the necessary claims with the carrier. Concealed damages not discovered until after removing the units from the packaging must be reported to the carrier within 24 hours of receipt.

Installation of accessories or field conversion should be accomplished before setting the unit in place or connection of any wiring, electric heat, duct, or piping.

## MOVING AND STORAGE

If the equipment is not needed for immediate installation upon its arrival at the job site, it should be left in its shipping carton and stored in a clean, dry area. Units must only be stored or moved in the normal upright position as indicated by the "UP" arrows on each carton at all times. If unit stacking is required, no more than stacking 2 units are permissible.

## SAFETY CONSIDERATIONS

Installation and servicing of this equipment can be hazardous due to system pressure and electrical components. Only trained and qualified personnel should install, repair, or service the equipment. Untrained personnel can perform basic functions of maintenance such as cleaning coils and replacing filters.



Before performing service or maintenance operations on the system, turn off main power to the unit. Electrical shock could cause personal injury or death.

When working on equipment, always observe precautions described in the literature, tags, and labels attached to the unit. Follow all safety codes. Wear safety glasses and work gloves. Use a quenching cloth for brazing, and place a fire extinguisher close to the work area. Overheating of the TXV during brazing will damage the valve and have adverse effects possibly causing injury or damage to the unit during operation.

## REFERENCE

This instruction should be used in conjunction with instructions supplied with each field installed accessory as well as outdoor section. Installer should pay particular attention to the words;

## Explanation of symbols

### Warning symbols



Safety instructions in this document are framed and identified by a warning triangle which is printed on a grey background.



Electrical hazards are identified by a lightning symbol surrounded by a warning triangle.

Signal words indicate the seriousness of the hazard in terms of the consequences of not following the safety instructions.

**NOTICE** indicates possible damage to property or equipment, but where there is no risk of personal injury.

**CAUTION** indicates possible personal injury.

**WARNING** indicates possible severe personal injury.

**DANGER** indicates possible risk to life.

### Important information



Notes contain important information in cases where there is no risk of personal injury or material losses and are identified by the symbol shown on the left. They are bordered by horizontal lines above and below the text.

## LOCATION

Locate the unit in an indoor area that allows easy general maintenance. The following issues should be considered when locating the air handler:

1. Allow sufficient room for the removal of the filter and access panels, and has enough room for service personnel to perform maintenance or repair. At least 30" clearance on the front side should be provided.
2. Provide sufficient room to make fluid, electrical, and duct connection(s).
3. If the unit is located in a confined space such as a closet, provisions must be made for return air to freely enter the space.
4. On horizontal units, allow adequate room below the unit for a condensate drain trap and do not locate the unit above supply piping.
5. When the coil is installed in a draw-thru application, it is recommended to trap the primary and secondary drain line. If the secondary drain is not used, it must be capped.
6. The cabinet will sweat when unit is installed in a non-conditioned space such as an attic or garage. Installer must provide protection such as full size auxiliary drain pan on all units installed in a non-conditioned space to prevent damage from condensation runoff. It is also recommended that the unit be completely insulated on the exterior with at least 1" thick fiberglass insulation with the vapor barrier on the outside.

These units are not approved for outdoor installation; therefore, they must be installed inside the structure being conditioned. Do not locate in areas that are subject to freezing.



*If electric heat is used, a minimum clearance of 1" must be maintained on all sides of the supply air duct and/or plenum continuously for up to 3'.*

## INSTALLATION/OPERATION SAFETY RULES

1. Read these rules and instructions carefully. Failure to follow these rules and the installation instructions could cause a malfunction of the unit, and a possible safety hazard. Keep these instructions nearby the unit for future reference.
2. While this unit has been designed and manufactured to comply with National codes, it is the installer's responsibility to install this unit to comply with National codes and/or prevailing local codes and regulations. BOSCH Group assumes no responsibility for units installed in violation of any code or regulation.
3. Before servicing, disconnect all electrical connections allow unit to cool. Components may be hot.



**WARNING: ALWAYS SHUT OFF ELECTRICITY WHEN WORKING ON UNIT.**  
*This will prevent any electrical shocks or burns.*

4. Ground the unit to prevent electric shock. All electrical wiring should be in accordance with the National Electric Code.
5. Duct work must be installed in accordance with the standards of the National Fire Protection Association (NFPA) for the installation of Air Conditioning, Warm Air Heating and Ventilating Systems (NFPA 90A and 90B). Duct work in non-conditioned spaces must be insulated to prevent formation of condensate and for maximum efficiency.
6. The safety testing agency label appearing on these units covers the unit and factory installed coil (if provided) only. It does not cover any other equipment. Exterior surface of cabinet may sweat when units is installed in a non-conditioned space such as an attic or garage. Installer must provide protection such as full size auxiliary drain pan on all units installed in a

non-conditioned space to prevent damage from condensation runoff. It is recommended that units installed in non-conditioned spaces be insulated with 1" thick fiberglass with the vapor barrier on the outside.

7. While designed to operate quietly when properly installed, several steps should be taken insure this. Use of isolation pads when mounting unit, flexible duct collars for discharge, and use of acoustical duct liners are all good installation practices that promote quite operation.
8. Cabinet insulation is rated for R-4.2 (standard). Some jurisdictions require R-6.0 on installations in a non-conditioned space. Add insulation 1" thick to exterior of unit to comply in these jurisdictions, putting the vapor barrier on the outside.
9. Upon leaving the factory, the refrigerant piping system is pressurized with nitrogen. Relieve pressure before opening up the system for pipe soldering or TXV removal by depressing the Schrader valve on coil manifold.



*Hot water can scald. Water heated to a temperature which will satisfy space heating can scald and permanently injure a person upon contact. Some people are more likely to be permanently injured by hot water than others; including the elderly and children. Check local, State, and National codes requiring certain temperature water at the hot water tap. Special precautions must be used in addition to using the lowest possible temperature setting that satisfies your hot water needs. A tempering device such as a mixing valve should be used at the hot water taps, or water heater.*

## MINIMUM CLEARANCES

These units have a 0" (zero inch) minimum clearance to combustible materials rating from all cabinet surfaces unless electric heat is installed; then a minimum of 1" clearance all around must be adhered to. The unit should be installed with serviceability clearance of 30" from the front of the

unit. The unit can be serviced entirely from the front, including replacing the filter. Be sure to route primary and secondary condensate drain piping so as not to obstruct replacement of filter.

## ARRANGEMENT

Units are shipped from the factory arranged to be installed in an upflow or horizontal right to left air flow position. Horizontal right to left means, when facing the front of the unit, when the unit is laid on its side, the supply air opening is to the left and the return opening is to the right. These models are field convertible to a horizontal left to right air flow position.

## UPFLOW APPLICATION

In an upflow installation the discharge outlet is at the top. Care should be taken to insure unit is level to permit proper condensate drainage. Normal upflow installation will be in a closet or basement. If installed in a closet, the closet should have a platform framed in, with an opening at the top of the platform centered in the closet. Connect the supply air outlet to a plenum. Install return air grilles from outside the closet to space below the platform. Platform must be at least 12" above the floor. If installed in a basement, run supply and return duct work in accordance with local codes.

Install the filter rack provided prior to placing the air handler on the bottom plenum

## HORIZONTAL APPLICATION

Horizontal applications will normally be used in an attic or crawl space. This type of installation requires a return air duct be attached to the unit inlet. The opposite end of the return air duct is attached to a return air filter grille through the ceiling or wall. Remove air filter from unit if filter grille is used. The unit is shipped in right to left configuration. For left to right applications (before connecting drains, refrigerant or water piping) remove coil and doors and move horizontal pan to right side. Reinstall coil and doors.



*If the air handler is to be installed in an unconditioned space, ensure that all refrigerant piping is fully insulated with at least ½" insulation, and that both supply and return ducts are fully insulated with a min of 1" insulation.*



While horizontal units may be installed on any level surface strong enough to hold their weight, they are typically suspended above a ceiling by threaded rods and a unistrut framing system; however hanging bracket kits (See Figure 1) are available from Bosch as an accessory (Part # 930-004 or 930-006). If the hanging bracket kit is purchased from Bosch, always refer to the hanging bracket assembly and installation instructions for details. The all thread rods must be securely anchored to the ceiling or fastened to the structural member intended on carrying the load of the air handler. Horizontal units installed above the ceiling must conform to all local codes. An auxiliary drain pan if required by code should be at least four inches larger than the bottom of the heat pump. Plumbing connected to the heat pump must not come in direct contact with joists, trusses, walls, etc.

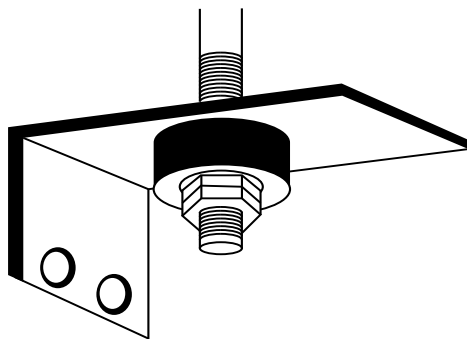

**Figure 1 – Mounting Bracket**

Some applications require an attic floor installation of the horizontal unit. In this case the unit should be set in a full size secondary drain pan on top of a vibration absorbing mesh. The secondary drain pan prevents possible condensate overflow or water leakage damage to the ceiling. The secondary drain pan is usually placed on a plywood base isolated from the ceiling joists by additional layers of vibration absorbing mesh. In both cases, a 3/4" drain connected to this secondary pan should be run to an eave or at a location that will be noticeable. If the unit is located in a crawl space, the bottom of the unit must be at least 4" above grade to prevent flooding of the electrical parts due to heavy rains.

The unit is shipped to be installed without modification in a right to left configuration. See **ARRANGEMENT** for details.

For left to right applications:

1. Remove the unit access panels.
2. Remove the cooling coil.
3. Move the condensate drain pan to the right side.
4. Reinstall the cooling coil.
5. Connect the condensate drains and refrigerant lines.
6. Reinstall unit access panels.

## DOWNFLOW APPLICATION

Contact the Bosch After Sales Department for purchasing a proper downflow conversion kit.



*It is mandatory to use an emergency auxiliary drain pan with any coil or air handler installed in an attic or above a finished ceiling.*

You must use the downflow conversion kit and follow the instructions below. Refer to Figures 2 and 3.

1. Remove the blower and control box access door.
2. Remove evaporator coil access door and discard it. The evaporator access door will not be re-used.
3. Remove evaporator coil assembly with drain pan by sliding out the front of the unit as shown in Figure 2.
4. Remove 6 screws (3 on each side of unit), securing evaporator coil support rails. Refer to Figure 2.
5. Flip the unit so the top is not the bottom.
6. Re-install the evaporator coil support rails in the holes provided in the unit casing as shown in Figure 3. Use the six (6) screws that were removed in step 4 to secure the evaporator coil support rails to the unit casing.
7. Re-install the cooling coil in the upright position as shown in Figure 3.
8. Remove the new evaporator coil access door from the kit and install over the evaporator section as shown in Figure 3.

9. Re-install the blower and control box access door in the upside down position and secure with the screws that were removed in Step 1.

Hydronic heat units cannot be used in the down flow position.

## DOWNFLOW CONVERSION KIT

### Disassembly Instructions

1. Remove evaporator coil door and discard. The door cannot be used in the downflow configuration. Remove the new evaporator coil door from the conversion kit box.
2. Remove the evaporator coil assembly with the drain pan by sliding it out of the front of the unit as shown in Figure 2.
3. Remove the 6 screws (3 on each side of the unit) securing the evaporator coil rails. Unit is ready to be reassembled in the downflow configuration.

Reassembled in the Downflow Configuration

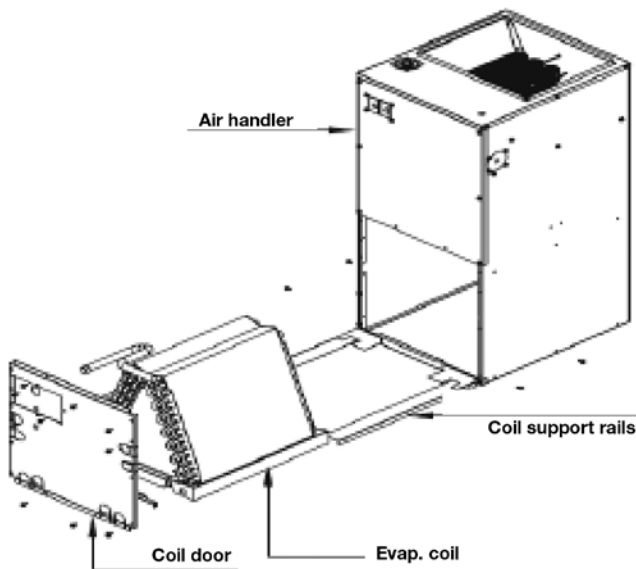

Figure 2. Evaporator Coil Disassembly for conversion to downflow

### Assembly Instructions

1. Invert the air handler 180° and reinstall the coil support rails, just above the blower. Use the six (6) screws that were removed in the disassembly instructions.

2. Slide the evaporator assembly back into the coil section. Evaporator must be installed so it is configured in the “A” position.
3. Install the new evaporator coil door that was removed from the kit.

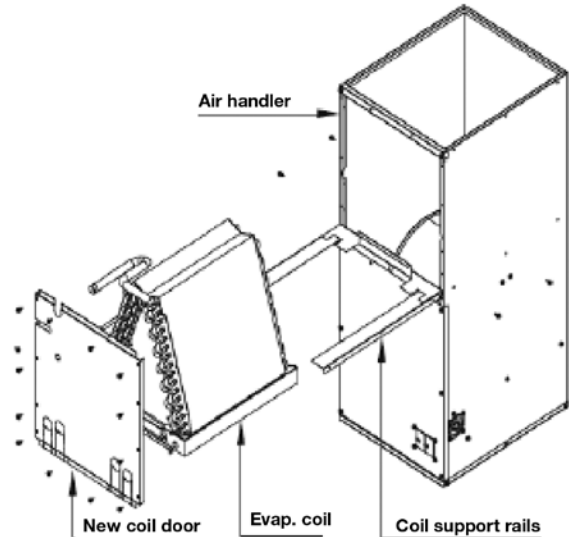

Figure 3. Evaporator Coil assembly after turning the air handler 180° for downflow conversion

## INSTALLATION ON COMBUSTIBLE FLOORING



**Combustible Floor Base MUST BE USED** when the unit is being installed on combustible flooring. The unit cannot be installed on carpeting. Failure to use the combustible floor base on combustible flooring or installing the unit on carpeting could result in a fire causing personnel injury, property damage or loss of life.

Before installing the combustible floor base make sure that there is a minimum of R-12 insulation between the sheet metal and any wood or combustible flooring. Refer to Figure 4 for typical combustible floor base installation.

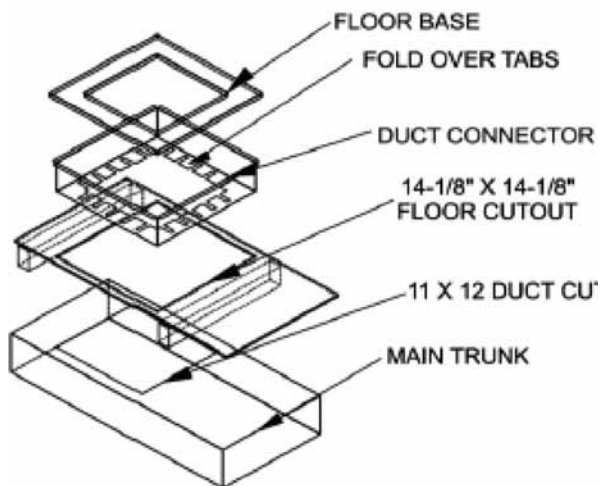

Figure 4: Combustible Floor Base Installation

## FURNACE INSTALLATION

### Installing The Air Handler

#### Closest Installation

Prior to installing the furnace make sure the holes are cut into the floor for the refrigerant tubing, the drain line, the electrical wiring, the thermostat wiring and the condenser control wiring.

1. Remove the top shipping cover and corner posts.
2. Remove the bottom shipping cover.
3. Remove the blower and control box access panel (door).
4. Remove the coil compartment access panel (door).
5. Place the unit into position using one of the following choices:
  - A. If the Combustible Floor Base is used you slide the unit on to the combustible floor base until the unit is touching the flanges on the back of the floor base.
  - B. If the Combustible Floor Base is not used you slide the unit over the duct opening until the opening in the unit lines up with the duct opening in the floor.
6. Secure the unit by one of the two choices:

- A. If the Combustible Floor Base is used you secure the furnace to the floor by drilling two holes through the furnace base and the floor base at the right and left front inside corners of the cabinet. Use two screws to secure the furnace to the floor.
- B. If the Combustible Floor Base is not used you secure the unit to the floor by drilling two holes through the furnace base at the left and right front inside corners of the cabinet. Use two screws to secure the unit to the floor.

7. Use caulking, sealers, and/or tape to seal between the combustible floor base and the opening on the unit or between the opening on the unit and the duct in the floor.
8. Connect the electrical supply wires and the thermostat control wires in the control box.
9. Connect the refrigerant lines to the coil.
10. Re-install the coil compartment access panel (door) and secure with the screws that were removed in Step 3.
11. Re-install the blower and control box access panel (door) and secure with the screws that were removed in Step 2
12. Turn the power on to the unit by following the procedure in the Users Information Manual.
13. Set the thermostat to the desired temperature.

## ELECTRICAL WIRING

Refer to the unit nameplate for specific electrical data.



*Disconnect power at main fuse or circuit breaker distribution panel before wiring unit to prevent shock or fire hazard.*

## LINE VOLTAGE WIRING

### POWER WIRING

The unit internal wiring is complete except for the power supply and the thermostat wires. The use of cable connectors on incoming power supply wires to relieve any strain on wiring is recommended.

Follow the steps below to connect the power supply wires.

### Single Circuit Line Wiring Connections

1. Remove the blower and control box access panel (door).
2. Remove the control box cover.
3. Install the cable connectors on the 7/8" dia holes on the left side and top right side of the control box.
4. Strip ½" of the insulation on the end of each wire.
5. Insert the wires through the holes in the casing and through the cable connectors.
6. Insert the black wire into the L1 screw terminal on the first circuit breaker from the top and tighten the set screw to clamp down on the wire.
7. Insert the white or red wire into the L2 screw terminal on the first circuit breaker down from the top and tighten the set screw to clamp down on the wire.
8. If you are using a single circuit for a 15kW or 20kW model you will need to install a black jumper wire from the L1 terminal on circuit breaker #1 to the L1 terminal on circuit breaker #2 and a white or red jumper wire from the L2 terminal on circuit breaker #1 to the L2 terminal on circuit breaker #2.
9. Insert the green wire into the ground lug and tighten the set screw.

### Dual Circuit Line Wiring Connections: 15kW or 20kW Models

10. You will need to insert the black wire from the second power supply into the L1 screw terminal on the second circuit breaker down from the top and tighten the set screw to clamp down on the wire.
11. You will need to insert the white or red wire from the second power supply into the L2 screw terminal on the second circuit breaker down from the top and tighten the set screw to clamp down on the wire.
12. You will need to insert both green wires into the ground lug and tighten the set screw.

13. Tighten the screws on the cable connectors until the power supply wires are securely fastened to the connector.

The 15kW and 20kW models may be connected to a single or dual branch circuit.



Refer to the NEC National Electrical Code (NFPA 70) or the Canadian Electrical Code, Part I (CSA C22.1) and local codes for wiring material requirements.

Field wiring must use copper conductors only. Tighten all wire connectors. Take care not to damage heater ceramic insulators on electric heat models. For correct field wire size see unit nameplate and field wiring table inside electrical compartment door or on blower housing. Use 75°C wire in unit wiring compartment.

Field wiring must comply with local and national electric codes. Power to the unit must be within the operating voltage range indicated on the unit nameplate or on the performance data sheet.



See unit for complete wiring diagram located inside electrical compartment door or on blower housing.



Operation of unit on improper line voltage or with excessive phase imbalance will be hazardous to the unit, constitutes abuse and may void the warranty.

Properly sized fuses or HACR circuit breakers must be installed for branch circuit protection. See unit nameplate for maximum fuse or breaker size. The unit is provided with a concentric knock-out, route power supply wiring through this opening. Always connect the ground lead to the grounding lug provided.

### FIELD INSTALLED ELECTRIC HEATER KITS

This instruction covers the physical installation of the following electric heat kits on the DX and HY series models. Refer to Table in back of this manual for electrical specifications.

The field installed electric heat accessories are used on cooling or heat pump models that were not purchased with electric heat from the factory. Each air handler model is approved for use with the field installed accessory electric heat kit.

## Installing The Heaters

1. Follow the instructions in the USERS INFORMATION MANUAL to properly shut down the air handler.
2. Remove the block off plate shown in Figure 13 and discard. Retain the screws; they will be used to secure the electric heater mount plate.
3. Insert electric heat kit into the opening where the block off plate was removed. Secure the mounting plate with the screws that were removed from the block off plate.
4. Connect the six pin male plug on the electric heater assembly to the six pin female plug mounted on the side of the low voltage control box divider panel.
5. Remove the wiring diagram from the kit, remove the paper that covers the adhesive back and place the electric heat wiring diagram over the wiring diagram located on the blower housing.
6. Follow the instructions in the USERS INFORMATION MANUAL to properly start up the air handler.



*To prevent damage, carefully insert the electric heating assembly through the rectangular opening in the front of the discharge opening so the heat element support rod is seated into the hole on the back side of the discharge opening.*



*After installing the electric heater, a one inch clearance must be maintained on all sides of the supply air duct and/or plenum for a minimum of thirty-six inches from the air handler discharge opening.*

## Power Supply Connections

If the air handler has been installed prior to installing the electric heaters or if an older unit is being replaced, the supply power wires must be checked to make sure the wires are the proper sizes to handle the current load for the heaters. If the supply power wire size is incorrect, new wires will

need to be installed. Follow the “Power Supply Wiring” instructions for proper installation.

**For circuit breaker models only** - After the supply wiring has been connected to the circuit breakers you must remove the transformer and indoor blower motor wires from the terminal block and connect them to load side of circuit breaker #1.

## Low Voltage Connections

If the air handler was previously installed, nothing will need to change on the low voltage wiring.

## VARIABLE SPEED MOTOR

Your DX or HY air handler is equipped with an electronic commutated motor (ECM) that will deliver constant air flow over a range of external static pressure amounts. As your air filter becomes more restricted through normal use, the torque of the motor is increased to deliver the same quantity of air flow. These motors are pre-programmed to have a zero (0) second delay “ON” delay for use with electric heat and a 60 second “OFF” delay in order to blow off remaining water condensate.

## REPLACING THE ECM MOTOR

1. Turn off all electrical supply circuits to the air handler at the main service panel.
2. Remove air handler blower door and switch the air handler circuit breaker(s) to “OFF”
3. Disconnect the power cable and the speed tap cable that connect to the blower motor.
4. Remove the three screws on the right side and the two screws on the left side of the blower mounting plate, then remove the angle bracket. Refer to Figure 5 below for screw locations

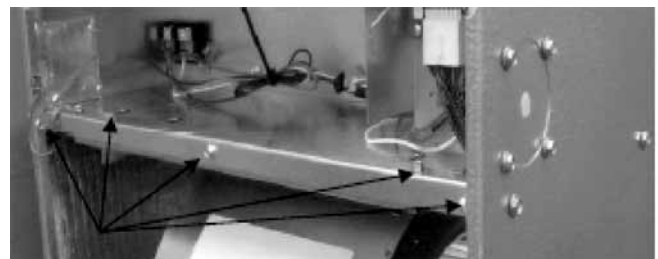

**Figure 5: Blower/Motor Assembly Removal**

5. Slide the blower out of the blower compartment and set on the floor.

6. Loosen the wheel set screw by placing wrench on the screw head and turning counter clockwise. Loosen the wheel set screw until the shaft can spin freely 360° while inside the wheel hub. The wheel set screw is located on the wheel hub on the opposite side of the motor.
7. Remove the blower motor from the blower housing by removing the screws on the sides of the housing that secure the blower to the housing.
8. Remove the blower motor mount assembly by loosening the belly band bolt and nut, then, remove the belly bands and mount legs.
9. Insert the new blower motor into the blower mounting bracket making sure the mounting legs are properly placed into the belly band and the legs are straight. Tighten the belly band screw and nut until belly band is securely fastened to the motor.
10. Place the motor into the housing so the mount leg holes line up with the rivet nuts in the housing. Place the screw into the mount leg holes and tighten until the mount legs are securely fastened to the housing.
11. Center the blower wheel in the housing, turn the motor shaft so the wheel set screw is located on the center of the flat spot of the shaft and tighten the set screw.
12. Connect the same two cables that were removed in step 3.
13. Slide the blower assembly into the blower deck, replace the angle bracket, insert the screws through the holes in the angle bracket and tighten the screws into the holes in the blower deck and the flanges in the casing.
14. Switch the circuit breakers to “ON” and replace air handler blower door.
15. Turn on all electrical supply circuits to the furnace at the main service (House Circuit Breaker) panel.
16. Set the thermostat to the desired temperature.

## ECM INTERFACE BOARD AND THERMOSTAT CONNECTIONS

The ECM Interface Board is used to connect the thermostat wiring and the control wiring from the remote condensing section or water-to-water unit.

In addition to providing a connecting point for thermostat wiring, the interface board also translates thermostat inputs into control commands for the variable speed programmable ECM DC fan motor and displays an LED indication of operating status. The thermostat connections and their functions are as follows:

<b>Y2</b>	Second Stage Compressor Operation
<b>Y1</b>	First Stage Compressor Operation
<b>G</b>	Fan Operation
<b>O</b>	Reversing Valve (energized in cooling)
<b>W1</b>	Auxiliary Electric Heat (runs in conjunction with compressor)
<b>EM/W2</b>	Emergency Heat (electric heat only)
<b>NC</b>	Transformer 24 VAC Common (extra connection)
<b>C</b>	Transformer 24 VAC Common (primary connection)
<b>R</b>	Transformer 24 VAC Hot
<b>HUM</b>	Dehumidification Mode

If the unit is being connected to a thermostat with a malfunction light, this connection is made at the unit's malfunction output or relay.



*If the thermostat is provided with a malfunction light powered off of the common (C) side of the transformer, the unit must be provided with a malfunction relay (Bosch option # 660-006) to properly energize the light. The relay coil will be wired across the (ALR) and (C) contacts on the unit's UPM board and the relay's normally open contacts across (ALR) and the malfunction light connection on the thermostat. If the thermostat is provided with a malfunction light powered off of the hot (R) side of the transformer, then the thermostat malfunction light connection should be connected directly to the (ALR) contact on the unit's UPM board.*

*This only applies when the air handler is paired with a Bosch condensing section. Other condensing manufactures may have different type of connections. Contact the manufacturer of the condensing section for proper connection methods when utilizing the malfunction light.*

To the left of the motor control board are a row of 3 red and 4 green LED's. These LED's indicate the operating status of the unit. They are labeled as follows:

- EM (red)** Emergency Heat On
- W2 (red)** Emergency Heat On
- W1 (red)** Auxiliary Heat On
- O (green)** Reversing Valve Energized, unit is in cooling mode
- Y2 (green)** Second Stage Compressor On
- Y1 (green)** First Stage Compressor On
- G (green)** Fan On

Towards the center of the motor control board is a single red LED labeled CFM that will blink intermittently when the unit is running and may flicker when the unit is off. This LED indicates the air delivery of the blower at any given time. Each blink of the LED represent 100 CFM of air delivery so if the LED blinks 12 times, pauses, blinks 12 times, etc. the blower is delivering 1200 CFM. Refer to the Blower Performance Table in the Technical Data section at the end of this manual for factory programmed air delivery settings for the DX and HY Series.

On the bottom right is a green LED labeled "DEHUMIDIFY". The dehumidify function will slow the speed of the fan by 30% to increase the latent capacity of the unit. In order to enable this function, cut the resistor just below the green LED. This operation cannot be reversed. Once you have enabled the dehumidification function, this will be a permanent setting.

On the right side of the motor control board are four sets of jumper pins labeled ADJUST, PROFILE, HEAT and COOL. The ADJUST set of pins are labeled NORM, (+), (-) and TEST. All DX and HY units will all be set on the NORM position from the factory, however, airflow can be increased (+) or decreased (-) by 15% from the pre-programmed setting by relocating the jumper in this section. The TEST position is used to verify proper motor operation. If a motor problem is suspected, move the ADJUST jumper to the TEST position and energize "G" on the thermostat connection block.

If the motor ramps up to 100% power, then the motor itself is functioning normally. Always remember to replace the jumper to NORM, (+) or (-) after testing and reset the unit thermostat to restore normal operation.



*Do not set the ADJ jumper to the (-) setting when electric heaters are installed. Doing so may cause the heaters to cycle on their thermal overload switches, potentially shortening the life of the switches.*

The other three sets of jumper pins are used to select the proper program in the ECM motor for the unit. Refer to the Blower Performance Table in the Technical Data section at the end of this manual for the proper jumper placement.



*Always disconnect power before changing jumper positions on the interface board.*

To the left of the red and green status LED's is a row of 1/4" male quick connects. These are used to connect the thermostat connections and to pass thermostat inputs on to the rest of the control circuit in the condensing section. Remember to always turn off unit power at the circuit breaker before attaching or disconnecting any wiring from these connections to avoid accidental short circuits that can damage unit control components. Thermostat input cable is routed through the concentric knockout on the right side of the cabinet, into the control box. The thermostat wires are connected to the pig tail leads in the control box with field supplied wire nuts.

## CONTROL WIRING

Field connections to the low voltage leads are made using appropriate field supplied wiring connectors. Consult installation instructions provided with accessory items for specific information on control wiring. Use 18 AWG minimum copper conductors for control wiring up to 50' between units. 16 AWG control conductors are recommended for lengths between 50' and 100'. Class 2 wiring is acceptable. Take care not to short control leads, transformer burnout could result. Some manufacturer's outdoor units are equipped with a 24 volt control transformer. If this type of outdoor

unit is used with this air handler, use a thermostat with isolating contacts to prevent inter-connection of two separate Class 2 circuits (RC terminal is used for the condensing section unit and RH terminal is used for the air handler. The jumper between RC and RH must be removed). Set thermostat heat anticipator at 0.15 amps for units 12KW or smaller, set at .30 amps for 15 KW and larger.

The labeled terminal block in the remote condensing section or water-to-water unit will identify the required connections.

## CONDENSATE DRAIN

The air handler "A" coil drain pan has two  $\frac{3}{4}$ " NPT female primary and two secondary connections (left or right hand). Horizontal pan has two  $\frac{3}{4}$ " NPT female, one primary and one secondary. Piping from each fitting used is to have 1-1/2 minimum trap and each run in such a manner as to provide enough slope for adequate drainage to a visible area. A drain line must be connected to the heat pump and pitched away from the unit a minimum of  $\frac{1}{8}$ " per foot to allow the condensate to flow away from the unit.

This connection must be in conformance with local plumbing codes. A trap must be installed in the condensate line to insure free condensate flow. (Heat Pumps are not internally trapped). A vertical air vent is sometimes required to avoid air pockets. (See Figure 6). The length of the trap depends on the amount of positive or negative pressure on the drain pan. A second trap must not be included.

The horizontal unit should be pitched approximately  $\frac{1}{4}$ " towards the drain in both directions, to facilitate condensate removal. (See Figure 7)

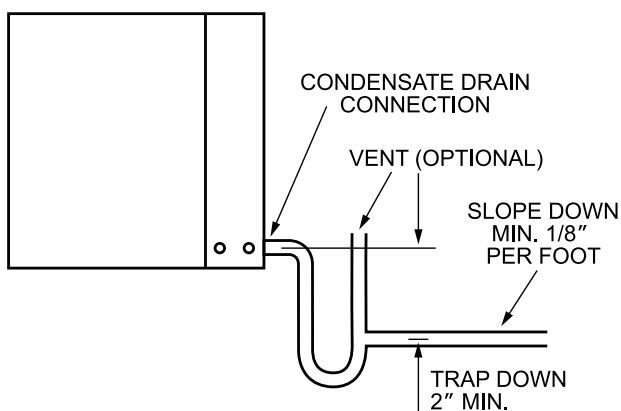

Figure 6



**BOSCH**

6720220327

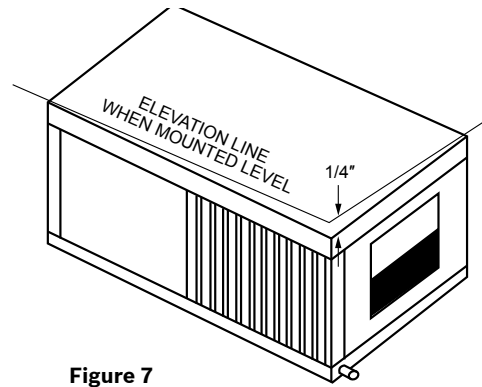

Figure 7

## DUCT SYSTEM

A supply air outlet collar is provided on all units to facilitate duct connections. Refer to the dimensional sheet at the beginning of this manual for physical dimensions of the collar.

A flexible connector is recommended for supply air duct connections on metal duct systems. All metal ducting should be insulated with a minimum of one inch duct insulation to avoid heat loss or gain and prevent condensate forming during the cooling operation. Applications utilizing uninsulated duct work are not recommended as the unit's performance will be adversely affected. Do not connect discharge ducts directly to the blower outlet. The factory provided air filter must be removed when using a filter back return air grill. The factory filter should be left in place on a free return system.

If the unit will be installed in a new installation which includes new duct work, the installation should be designed using current ASHRAE procedures for duct sizing. If the unit is to be connected to existing ductwork, a check should be made to assure that the duct system has the capacity to handle the air required for the unit application. If the duct system is too small, larger ductwork should be installed. Check for existing leaks and repair.

The duct system and all diffusers should be sized to handle the designed air flow quietly. To maximize sound attenuation of the unit blower, the supply and return air plenums should be insulated. There should be no direct straight air path thru the return air grille into the heat pump. The return air inlet to the heat pump must have at least one 90 degree turn away from the space return air grille. If air noise or excessive air flow are a problem, the



blower speed can be changed to a lower speed to reduce air flow. (Refer to ECM motor interface board section in this manual and the Blower Performance Table in the Technical Data section at the end of this manual.)

## PIPING

Supply and return piping must be as large as the unit connections on the heat pump (larger on long runs). Never use flexible hoses of a smaller inside diameter than that of the fluid connections on the unit. Bosch condensing section units are supplied with either a copper or optional cupro-nickel condenser. Copper is adequate for ground water that is not high in mineral content. Should your well driller express concern regarding the quality of the well water available or should any known hazards exist in your area, we recommend proper testing to assure the well water quality is suitable for use with water source equipment. In conditions anticipating moderate scale formation or in brackish water a cupro-nickel heat exchanger is recommended.

Both the supply and discharge water lines will sweat if subjected to low water temperature. These lines should be insulated to prevent damage from condensation.

All manual flow valves used in the system must be ball valves. Globe and gate valves must not be used due to high pressure drop and poor throttling characteristics. Never exceed the recommended water flow rates as serious damage or erosion of the water to refrigerant heat exchanger could occur. Refer to the Technical Data section at the end of this manual to determine the recommended water flow rate for specific conditions.

Always check carefully for water leaks and repair appropriately. Units are equipped with female pipe thread fittings. Consult the specification sheets of the paired condensing section for sizes. Teflon tape sealer should be used when connecting water piping connections to the units to insure against leaks and possible heat exchanger fouling. Do not over-tighten the connections. Flexible hoses should be used between the unit and the rigid system to avoid possible vibration. Ball valves should be installed in the supply and return lines for unit isolation and unit water flow balancing.

## DX REFRIGERANT PIPING

Air handlers with DX type evaporator coils require liquid and suction piping sized in accordance with condensing unit manufacturer's recommendations. The evaporator coils have sweat copper connections. Refrigerant lines should be soldered with silver solder or other high temperature brazing alloy.

The suction line must be insulated for satisfactory operation to avoid creating condensation. If the condensing unit is located over the evaporator coil, then oil traps are required at equal intervals along the suction line.

Horizontal suction line runs should be sloped 1" every 20' towards the condensing unit. The manufacturer recommends that dry nitrogen be flowed through the refrigerant lines during the soldering operation. Liquid line is capped.

- Install 1 oil trap for a height difference of 15 ft to 25 ft (4.6 m to 7.6 m) between condensing section and air handler.
- Install 2 oil traps for a height difference of 26 ft to 50 ft (7.9 m to 15.2 m) between condensing section and air handler.
- Install 3 oil traps for a height difference of 51 ft to 100 ft (15.5 m to 30.5 m) between condensing section and air handler.

It is not recommended that a height difference of more than 100 ft exists between the two units.

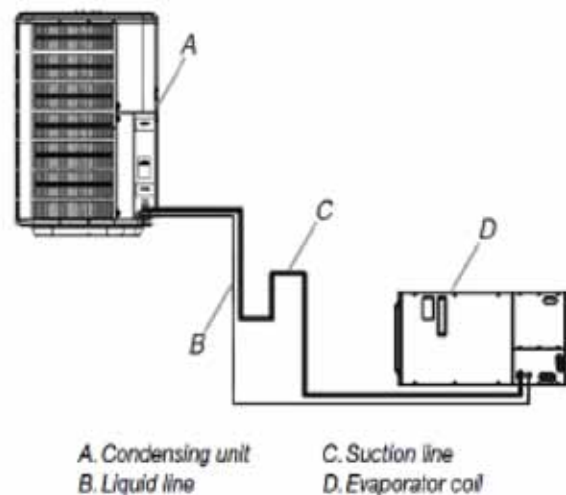

Figure 8: Evaporator Below Condenser Piping



*Pressure drop in liquid must not exceed 30 psi or erratic operation and thermostatic expansion damage will occur.*

## WATER PIPING

All piping must be supported independent of coils to prevent vibration and stress on coil headers. Swing joints or flexible fittings must be provided to absorb expansion and contraction strains. Rigid piping reduces the effectiveness of vibration isolators. Water piping should always be connected so that the entering water is on the bottom connection of the water coil. Coils must be adequately vented in order to prevent air binding. Units are provided with manual air vents mounted through the manifold panel.

## CHILLED WATER PIPING

Supply and return chilled water piping to the coil should be 3/4 inch ID up to 42,000 BTUs, 1 inch on units greater than 42,000 BTUs. Water piping must always be connected so that the entering water is on the leaving side of the coil.

## HOT WATER PIPING

If a residential water heater is used for space heating water, do not exceed a distance of 70 feet between the air handler and the water heater. The water heater should be the quick recovery type. Air handler and water heater must be located indoors and not subject to freezing temperatures.



*Air handler must be located so that if any connections should leak, water will not cause damage to the adjacent area. When such locations can't be avoided, a suitable drain pan should be installed under the air handler, not over 1-1/2" deep, with minimum length and width at least 2" greater than the air handler dimensions and connected to an adequate drain. Under no circumstances is the manufacturer to be held liable for any water damage in connection with this air handler.*

Total piping should not exceed 140 feet. All piping should be 3/4" ID (7/8" OD) copper. CPVC piping may be used in applications where the water

temperature does not exceed 150°F. It is recommended that the water shut-off valve for the water heater be located close to the water heater. Isolation valves are also recommended.

It is recommended that any devices installed, which could create a closed system, have a bypass and/or the system have an expansion tank to relieve the pressure built up by thermal expansion in the water system.



*Toxic chemicals such as used for treatment of boilers or non-potable water heating appliances shall never be introduced into a potable water space heating system.*



*When the system required water at temperatures higher than required for other uses, a means such as a mixing valve shall be installed to temper the water for those uses in order to reduce the scald hazard potential.*

After piping has been installed, allow the system to fill with water and check connections for leaks. To insure complete filling of the system, follow start-up procedure.

## FIELD INSTALLED TXV

Thermal expansion valve (TXV) can be used on both heat pump and air conditioning applications. All TXVs have a built in check valve making them heat pump capable. All are externally equalized with non-adjustable superheat and are available with 15% bleed construction. Hard start capability for outdoor units is not normally required when 15% bleed valve is used. The external equalizer line attached to the TXV has a female flare nut with built in Schrader valve depressor that attaches to the Schrader valve port provided on coils.



*With reference to the figure 9, the TXV assembly is to be installed between the flowrator distributor and the existing liquid line attached to the flowrator distributor.*

**Installation Steps:**

1. After coil pressure has been relieved, turn the female swivel nut counter-clockwise to remove.
2. Remove the piston from the flowrator distributor fitting using a small diameter wire or paper clip. (ALWAYS REMOVE PISTON FROM DISTRIBUTOR BODY WHEN TXV IS INSTALLED).
3. Attach the TXV by connecting the female swivel nut on TXV outlet to the flowrator distributor (aligning Teflon seal first) and torque swivel nut to 10-30 ft. lbs.
4. Attach liquid line with female swivel nut to male rotalock fitting on TXV inlet (Aligning Teflon seal first) and torque swivel nut to 10-30 ft. lbs.  
Remove the cap on Schrader valve port on coil manifold. Attach equalizer tubing with 1/4" female flare nut that include depressor to this male Schrader port. Torque nut to 10-30 ft. lb.
5. Install the TXV bulb to the suction manifold of coil or the suction line using the two bulb clamps furnished with kit.
  - A. Bulb should be installed on a horizontal run of the manifold if possible. On lines less than 7/8" OD the bulb may be installed on top of the line. With 7/8" OD and over, the bulb should be installed in a position at about 4 or 8 o'clock.
  - B. If bulb installation is made on a vertical run, the bulb should be located at least 6 inches from any bend, and on the tubing side opposite the plane of the bend. On vertical bulb installations, the bulb should be positioned with the bulb capillary tube at the top.
  - C. The bulb should be insulated using thermal insulation to protect it from the effect of the surrounding ambient temperature.
6. After completing installation of TXV (including equalizer tube), it will be necessary to leak check the coil and evacuate the coil through the service access fittings of liquid and suction line valves.

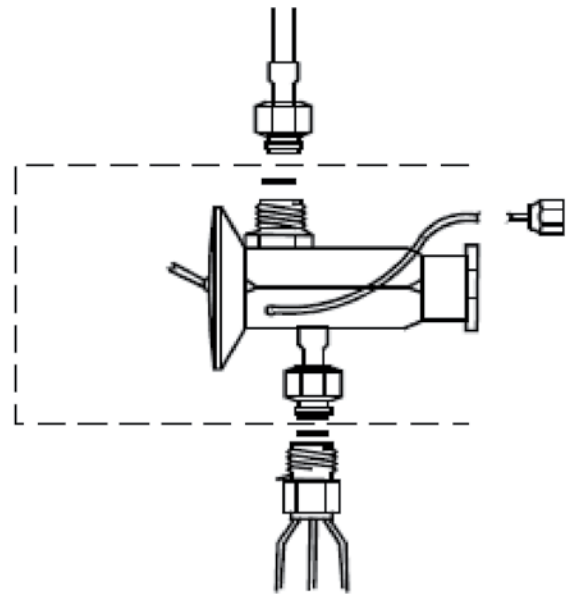

**Figure 9: Typical TXV Connections**

**CHECK TEST AND START UP**

**UNITS WITH ELECTRIC HEAT**

The unit should be tested after the system has been completely installed to determine proper operation. Unit is equipped with heater time delay controls. All heating elements should turn on within one minute.



*Circuit breakers are equipped with a visual "visi-trip" red flag indicator. If red indicator shows that circuit breaker has tripped, this indicated that a problem exists in your system which should be corrected before resetting breaker.*

**UNITS WITH HOT WATER HEATING**



*Heating system should not be switched on until system is filled and all the air in the hot water coil has been vented.*

1. Fill and pressurize the water heater and air handler.
2. The water heater should be started.

3. Vent air from the water tank by opening a hot water spigot.
4. Vent and flush the supply and return lines by attaching a hose to the volume purge valve and running purge water to a safe location. Run approximately 5 gallons of water at a high flow rate to purge.
5. Energize the unit by switching on the line voltage source and the thermostat. The fan and pump should start simultaneously. The water coil should become warm after a few minutes of operation.
6. Units are rated at temperatures up to 180°F. Set water source temperature at design temperature and take proper safeguards for water usage at supply points as per local codes and safety considerations.



*Heat pump condensing sections are not cable of producing 180°F water. This must come from a boiler source. Contact Bosch for ratings and capacities for boiler system use.*

## SYSTEM SHUT-DOWN

For short periods of time during freezing temperatures if the system is to be left unused, to prevent freezing of the air handler and piping, do the following:

1. Do not turn the system off; leave the thermostat to the air handler left on the heat setting to maintain a space temperature above freezing conditions.
2. If the water heater and/or air handler must be shut down for extended periods, a qualified service technician should insure that the air handler and coil are completely drained of water.

## PERIODIC MAINTENANCE

The filter must be changed monthly to permit proper airflow for safe and efficient operation. All other maintenance should be performed by a licensed technician.

## CONNECTING THE UNIT MOUNTED CONTROLLER WATER-TO-WATER UNIT TO YOUR HYDRONIC (HY) AIR HANDLER



In order to allow your room thermostat or DDC controller to control the operation mode (cooling or heating) that your water-to-water unit is running, you will need to purchase the DY AUTO CHANGEOVER CONTROLLER

(Bosch Part #:7 738 000 397).



*This accessory is only needed for a HY air handler with a paired water-to-water unit with a unit mounted controller. If your water-to-water unit is remote controlled, it is already set up to function correctly with an HY air handler.*

This controller will convert an AC signal from the thermostat or DDC controller when a call for cooling or heating is made based upon the set point to a resistance value that the unit mounted controller will interpret as a water temperature. This will cause the water-to-water unit to go into cooling or heating mode as dictated by the thermostat or DDC controller call.

Connect the “S2” connections on the back of the water-to-water unit mounted controller to the “S2” connections on the Auto Changeover Controller. If a thermostat will be used to control the air handler, then route a wire from the “O” connection and from the “C” connection from the back of the

thermostat to the “O” & “C” connections on the Auto Changeover Controller. If a DDC controller with a dry contact is to be used then route wires from the “DRY” contacts of the DDC controller to the “DRY” contacts on the Auto Changeover Controller. Refer to Figure 10 below.

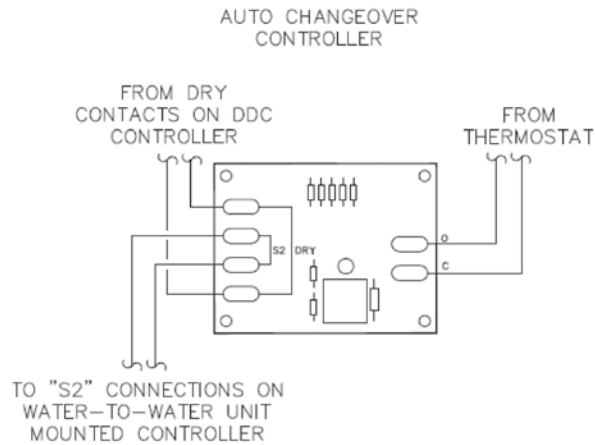
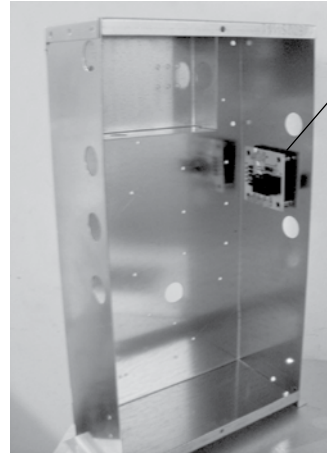

Figure 10



When installing the controller, locate the four holes provided in the electrical box on the right hand side and snap in the location as shown.



Either use the “O” & “C” connection from the thermostat or the “DRY” contacts from a DDC controller on this accessory. Do not attempt to connect both.

If the water-to-water unit is an existing piece of equipment already in service, and the hydronic air handler is being added to the system, then locate the two wires connected to the “S2” connections on the back of the unit mounted controller and follow them to where they are attached to the side of the water pipe (the point of contact will be underneath some insulation tape). Carefully remove the insulation tape to free the loose ends of the wire. Crimp on 1/4” insulated terminal connections to the wires and proceed following the instructions already mentioned. Replace any damaged insulation tape to ensure that no exposed piping remains.



Use 18 AWG wire when making all connections to the Auto Changeover Controller to the unit mounted controller and to the thermostat or DDC controller.

FULL LOAD "Y1 + Y2" BLOWER PERFORMANCE - DX UNITS															
MODEL	NOMINAL TONS	MOTOR HP	VOLTS, 1 PH 50/60 HZ	BLOWER WHEEL	JUMPER	CFM @ 0.1"	CFM @ 0.2"	CFM @ 0.3"	CFM @ 0.4"	CFM @ 0.5"	CFM @ 0.6"	CFM @ 0.7"	CFM @ 0.8"	CFM @ 0.9"	CFM @ 1.0"
DX025	2	1/3	240	9X6	A	993	993	993	993	993	993	974	953	921	610
					B	954	954	954	954	954	954	954	906	878	436
					C	877	877	877	877	877	877	877	863	782	436
					D	767	767	767	767	767	767	767	767	643	620
DX035	3	1/2	240	10X7	A	1556	1556	1556	1556	1556	1556	1528	1508	1479	1448
					B	1547	1547	1547	1547	1547	1547	1528	1498	1469	1448
					C	1275	1275	1275	1275	1275	1275	1275	1275	1275	1275
					D	1124	1124	1124	1124	1124	1121	1116	1110	1099	1088
DX049	4	3/4	240	12X9	A	2325	2325	2325	2297	2255	2212	2169	2139	2109	2064
					B	2255	2255	2255	2255	2227	2227	2184	2139	2109	2079
					C	2048	2048	2048	2048	2048	2048	2033	2033	2017	2017
					D	1920	1920	1920	1920	1920	1920	1904	1904	1887	1870
DX061 DX071	5 & 6	1	240	12X10	A	2566	2566	2566	2518	2505	2481	2431	2406	2381	2355
					B	2549	2549	2549	2513	2489	2464	2426	2401	2375	2336
					C	2537	2537	2537	2537	2513	2476	2451	2413	2375	2336
					D	2525	2525	2525	2501	2476	2451	2413	2388	2349	2323

PART LOAD "Y1" BLOWER PERFORMANCE - DX UNITS															
MODEL	NOMINAL TONS	MOTOR HP	VOLTS, 1 PH 50/60 HZ	BLOWER WHEEL	JUMPER	CFM @ 0.1"	CFM @ 0.2"	CFM @ 0.3"	CFM @ 0.4"	CFM @ 0.5"	CFM @ 0.6"	CFM @ 0.7"	CFM @ 0.8"	CFM @ 0.9"	CFM @ 1.0"
DX025	2	1/3	240	9X6	A	849	849	849	849	849	849	849	841	600	600
					B	754	754	754	754	754	746	726	726	718	412
					C	692	692	692	692	692	683	679	670	670	400
					D	598	598	598	598	598	598	580	580	580	574
DX035	3	1/2	240	10X7	A	1438	1438	1438	1438	1438	1438	1438	1438	1428	1417
					B	1227	1227	1227	1227	1227	1227	1227	1227	1227	1215
					C	955	955	955	955	955	955	955	955	941	928
					D	844	844	844	844	832	844	837	829	815	808
DX049	4	3/4	240	12X9	A	2169	2169	2169	2169	2169	2169	2154	2139	2109	2064
					B	1747	1747	1747	1747	1747	1747	1747	1729	1729	1710
					C	1575	1575	1575	1575	1575	1575	1575	1575	1575	1575
					D	1492	1492	1492	1492	1492	1492	1492	1492	1492	1470
DX061 DX071	5 & 6	1	240	12X10	A	2474	2474	2474	2474	2456	2415	2391	2354	2335	2304
					B	2305	2305	2305	2305	2298	2292	2292	2279	2273	2266
					C	2106	2106	2106	2106	2106	2099	2099	2099	2099	2092
					D	1895	1895	1895	1895	1887	1879	1879	1879	1879	1879

UNIT	PAIRED WITH TA CONDENSING SECTION				PAIRED WITH CE CONDENSING SECTION			
	PART LOAD AIR FLOW	FULL LOAD AIR FLOW	MOTOR BOARD JUMPERS SETTING FOR NORMAL OPERATION	ADJUSTMENT SETTING ("NORM", "+", OR "-")	PART LOAD AIR FLOW	FULL LOAD AIR FLOW	MOTOR BOARD JUMPERS SETTING FOR NORMAL OPERATION	ADJUSTMENT SETTING ("NORM", "+", OR "-")
DX025	750	950	JUMPER "B"	"NORM"	500	800	JUMPER "D"	"NORM"
DX035	1000	1200	JUMPER "C"	"NORM"	800	1200	JUMPER "C"	"NORM"
DX049	1300	1700	JUMPER "D"	"NORM"	1000	1600	JUMPER "D"	"."
DX061	1500	2000	JUMPER "D"	"NORM"	1400	2000	JUMPER "D"	"."
DX071	1500	2200	JUMPER "D"	"NORM"	1400	2200	JUMPER "D"	"."

**SYSTEM PIPING SCHEMATICS**

**CLOSED LOOP – GROUND LOOP SYSTEM WITH GEOTHERMAL STORAGE TANK RESIDENTIAL APPLICATION**

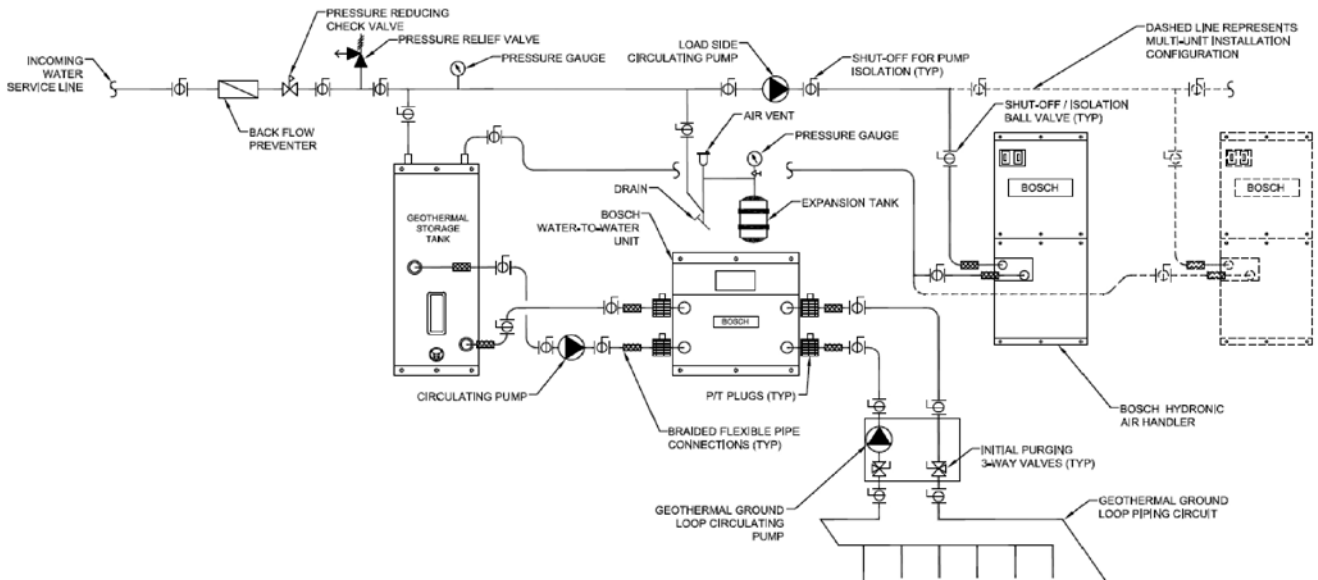

**OPEN SYSTEM – GROUND WATER SYSTEM WITH GEOTHERMAL STORAGE TANK RESIDENTIAL APPLICATION**

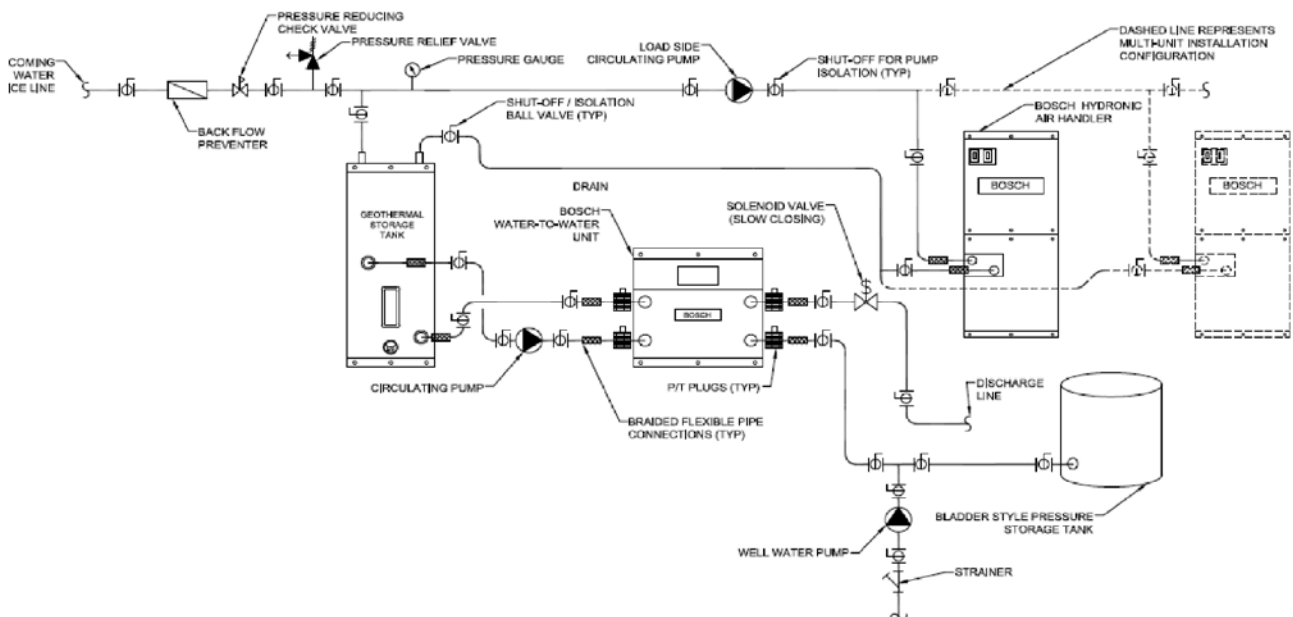



## ELECTRICAL DATA

Electrical Data																
Model	Motor Data		Electric Heater Data						Minimum Circuit Ampacity				Maximum Overcurrent Protection			
	HP	Amps (1)	# of Circuits	kW	Amps 208 V	Amps 208 V	Amps 240 V	Amps 240 V	MCA 208 V	MCA 208 V	MCA 240 V	MCA 240 V	MOCP 208 V	MOCP 208 V	MOCP 240 V	MOCP 240 V
					Cr1	Cr2	Cr1	Cr2	Cr1	Cr2	Cr1	Cr2	Cr1	Cr2	Cr1	Cr2
DX025	1/3	0.78	0	0	-	-	-	-	1.0	-	1.0	-	10	-	10	-
			1	5	18.0	-	20.8	-	23.3	-	26.8	-	35	-	35	-
			1	10	36.1	-	41.7	-	45.9	-	52.9	-	50	-	60	-
DX035	1/2	2.03	0	0	-	-	-	-	2.5	-	2.5	-	10	-	10	-
			1	5	18.0	-	20.8	-	24.6	-	28.1	-	35	-	40	-
			1	10	36.1	-	41.7	-	47.1	-	54.1	-	60	-	60	-
			2	15	18.0	36.1	20.8	41.7	24.5	47.2	28.0	54.2	30	50	35	60
DX049	3/4	2.5	0	0	-	-	-	-	3.1	-	3.1	-	15	-	15	-
			1	5	18.0	-	20.8	-	25.0	-	28.5	-	35	-	40	-
			1	10	36.1	-	41.7	-	47.6	-	54.6	-	60	-	70	-
			2	15	18.0	36.1	20.8	41.7	25.0	47.6	28.5	54.6	30	50	30	60
			2	20	36.1	36.1	41.7	41.7	47.6	47.6	54.6	54.6	50	50	60	60
DX061 DX071	1	3.8	0	0	-	-	-	-	4.7	-	4.7	-	15	-	15	-
			1	5	18.0	-	20.8	-	26.3	-	29.8	-	35	-	40	-
			1	10	36.1	-	41.7	-	48.8	-	55.8	-	60	-	70	-
			2	15	18.0	36.1	20.8	41.7	26.3	48.9	29.8	55.9	30	50	35	60
			2	20	36.1	36.1	41.7	41.7	48.9	48.9	55.9	55.9	50	50	60	60

(1) = Rated Motor Amps @0.3" ESP (DOE External Static Rating Point)

**ELECTRICAL DIAGRAMS**

**Air Handler without Electric Heat**

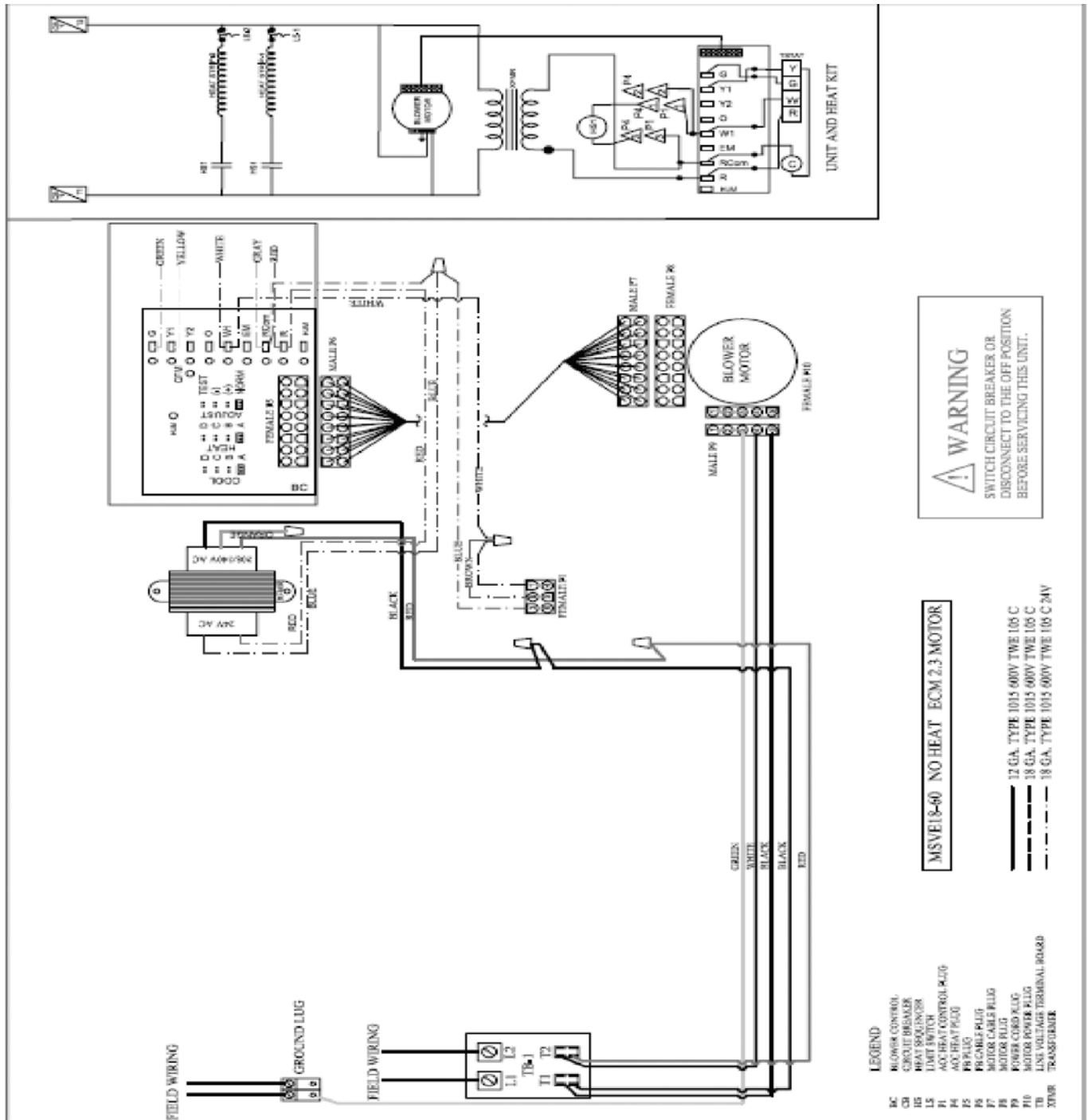

ELECTRICAL DIAGRAMS

5Kw Electric Heater Package

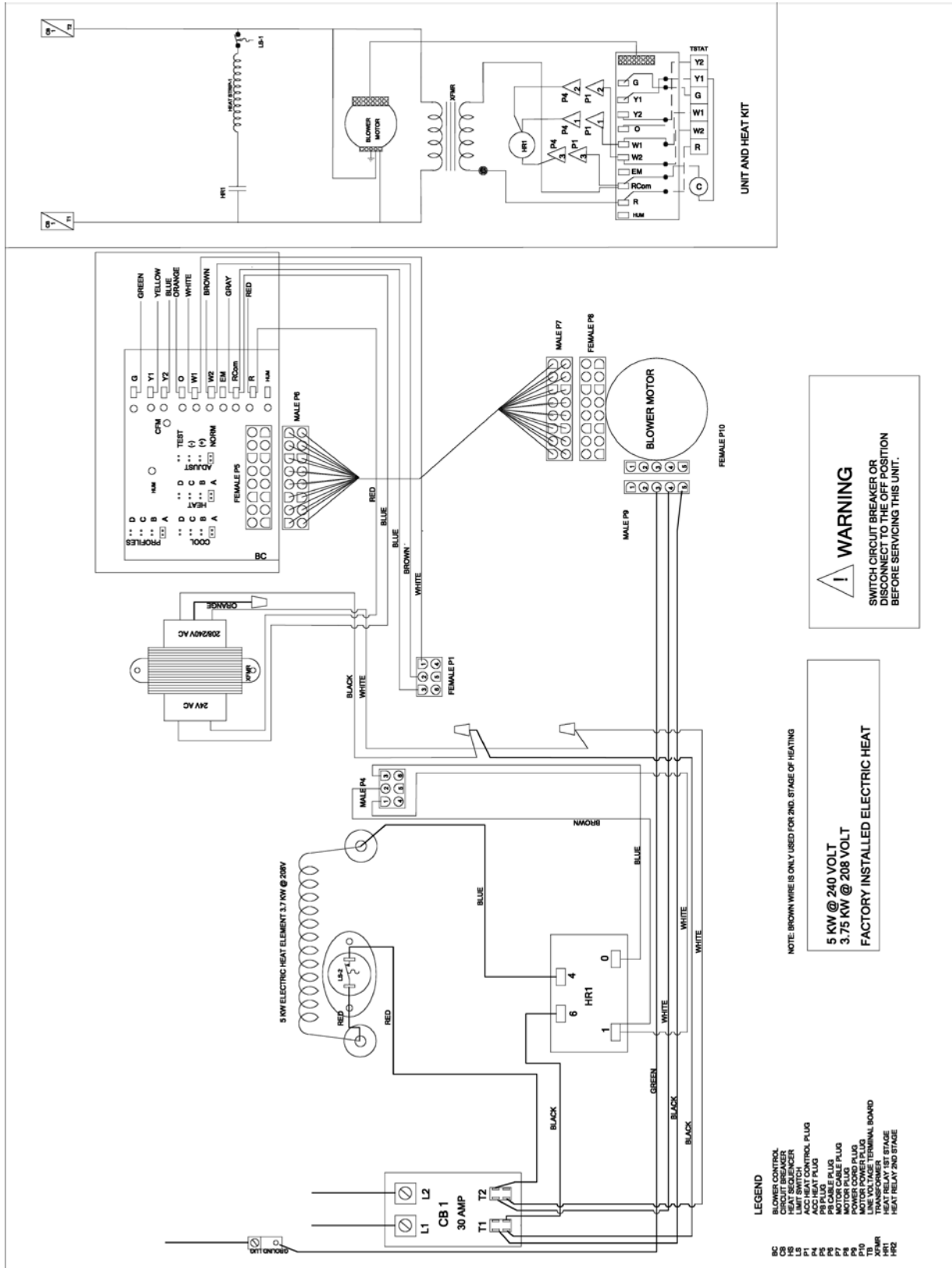

ELECTRICAL DIAGRAMS

10Kw Electric Heater Package

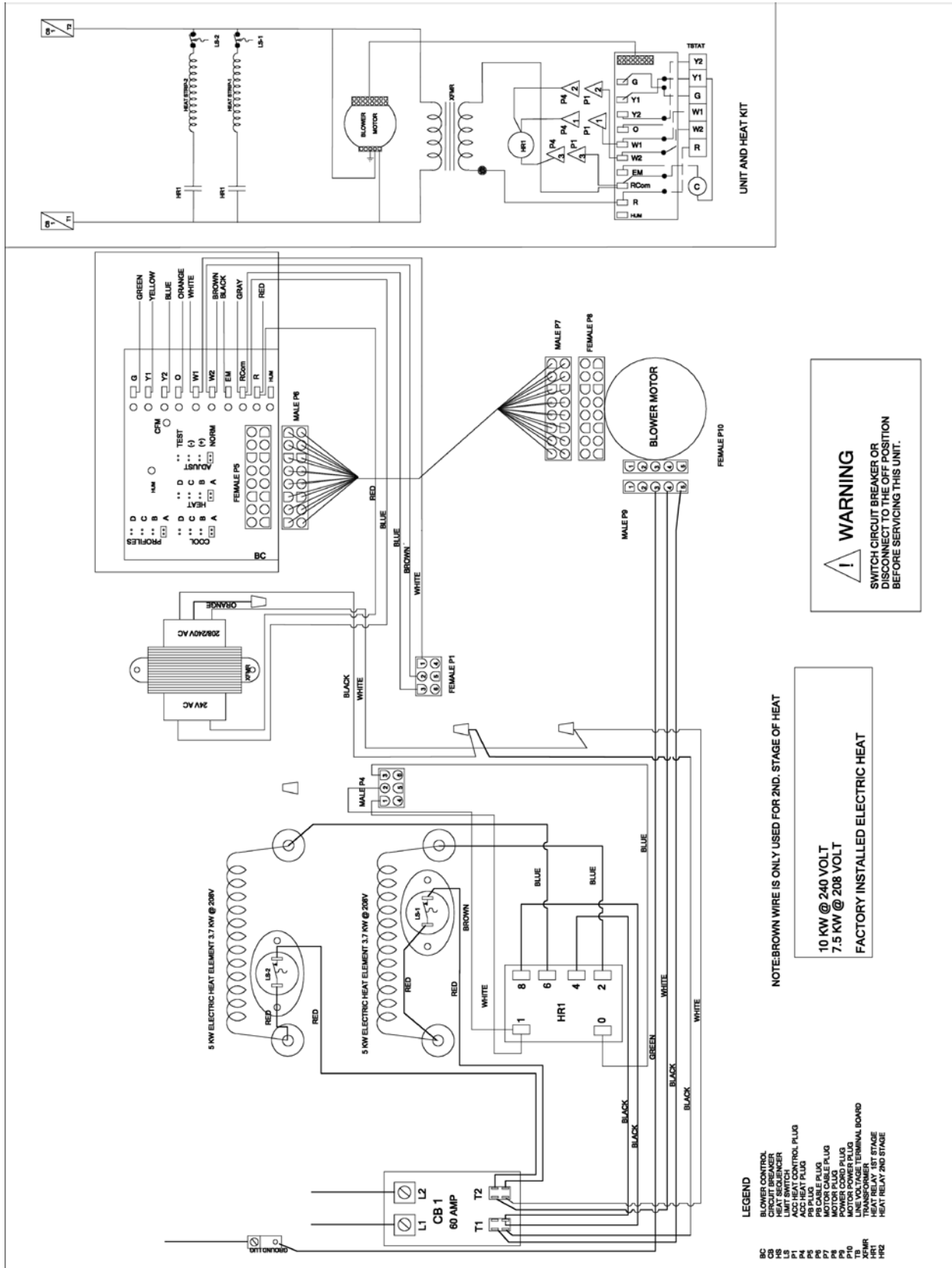

**ELECTRICAL DIAGRAMS**

**15Kw Electric Heater Package**

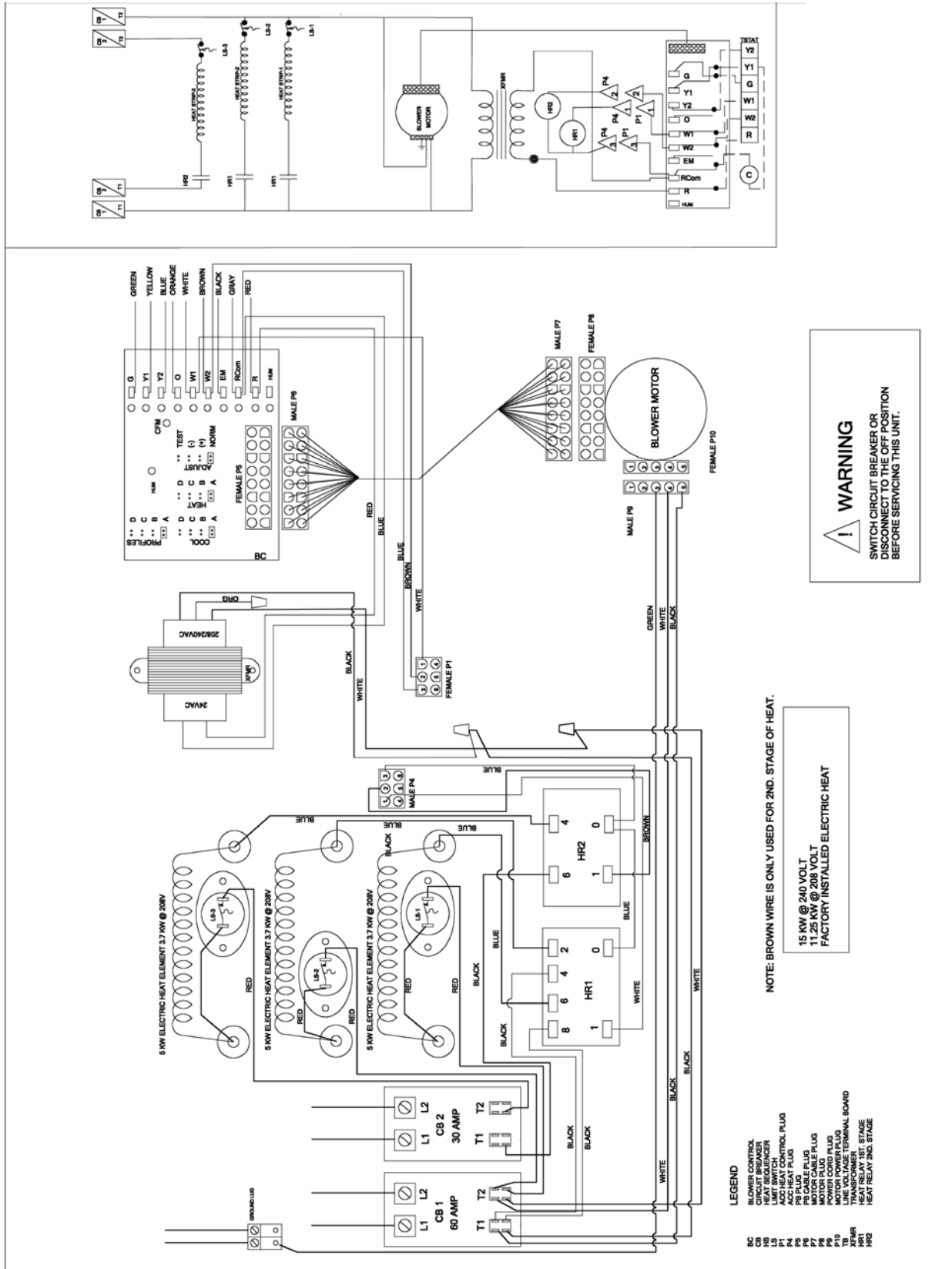

ELECTRICAL DIAGRAMS

20Kw Electric Heater Package

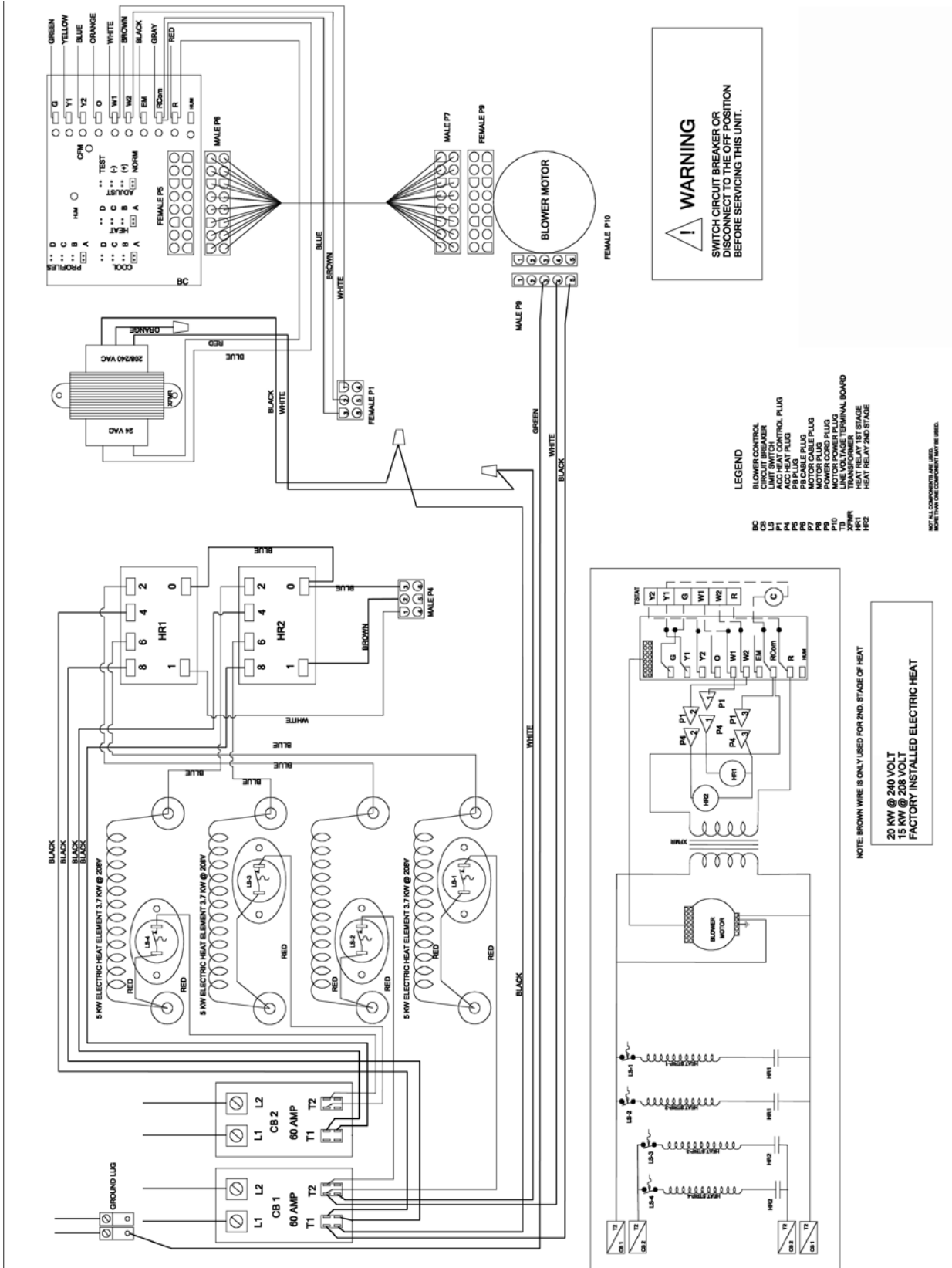

**Customer Data**

Customer Name \_\_\_\_\_

Date \_\_\_\_\_

Address \_\_\_\_\_

Phone \_\_\_\_\_

Unit Number \_\_\_\_\_

**Unit Nameplate Data**

Unit Make \_\_\_\_\_

Model Number \_\_\_\_\_

Serial Number \_\_\_\_\_

Refrigerant Charge (oz) \_\_\_\_\_

Compressor: RLA \_\_\_\_\_ LRA \_\_\_\_\_

Blower Motor: FLA (or NPA) \_\_\_\_\_ HP \_\_\_\_\_

Maximum Fuse Size (Amps) \_\_\_\_\_

Minimum Circuit Ampacity (Amps) \_\_\_\_\_

**Operating Conditions**

	Cooling Mode	Heating Mode
Entering / Leaving Air Temp	_____ / _____	_____ / _____
Entering Air Measured at:	_____	_____
Leaving Air Measured at:	_____	_____
Entering / Leaving Fluid Temp	_____ / _____	_____ / _____
Fluid Flow (gpm)	_____	_____
Fluid Side Pressure Drop	_____	_____
Suction / Discharge Pressure (psig)	_____ / _____	_____ / _____
Suction / Discharge Temp	_____ / _____	_____ / _____
Suction Superheat	_____	_____
Entering TXV / Cap Tube Temp	_____	_____
Liquid Subcooling	_____	_____
Compressor Volts / Amps	_____ / _____	_____ / _____
Blower Motor Volts / Amps	_____ / _____	_____ / _____

**Auxiliary Heat**

Unit Made \_\_\_\_\_

Model Number \_\_\_\_\_

Serial Number \_\_\_\_\_

Max Fuse Size (Amps) \_\_\_\_\_

Volts / Amps \_\_\_\_\_

Entering Air Temperature \_\_\_\_\_

Leaving Air Temperature \_\_\_\_\_

Bosch group 601 N.W. 65th Court, Ft. Lauderdale, FL 33309  
 Phone: 954-776-5471 Fax: 954-776-5529  
 www.fhp-mfg.us



# BOSCH

601 N.W. 65th Court, Ft. Lauderdale, FL 33309  
Phone: 954-776-5471 | Fax: 954-776-5529  
[www.boschtaxcredit.com](http://www.boschtaxcredit.com) | [www.bosch-climate.us](http://www.bosch-climate.us)

