

# Performance Data

## AHRI / ISO 13256-1 PERFORMANCE DATA - PART LOAD - PAIRED WITH CE CONDENSING SECTION

ENTERING WATER TEMPERATURES																						
			86°F				68°F				59°F				50°F				68°F		41°F	
			WATER LOOP				GROUND WATER				GROUND WATER				GROUND LOOP							
CAPACITY AND EFFICIENCY DATA																						
MODEL	FLUID FLOW RATE (GPM)	AIR FLOW (CFM)	COOLING CAPACITY (WLHP)	EER (WLHP)	HEATING CAPACITY (WLHP)	COP (WLHP)	COOLING CAPACITY (GWHP)	EER (GWHP)	HEATING CAPACITY (GWHP)	COP (GWHP)	COOLING CAPACITY (GLHP)	EER (GLHP)	HEATING CAPACITY (GLHP)	COP (GLHP)								
DX025	6	500	19,000	17.2	21,500	5.2	21,500	29.9	17,500	4.8	20,500	24.7	15,500	4.4								
DX035	9	800	24,000	16.7	30,500	5.2	27,500	28.2	23,500	4.6	26,500	23.6	20,500	4.3								
DX049	12	1,000	34,000	15.3	39,500	5.2	39,500	25.0	32,000	4.3	37,500	21.3	28,500	4.0								
DX061	14	1,400	42,500	16.2	49,500	5.4	48,500	27.5	40,000	4.3	46,500	22.8	36,500	3.9								
DX071	18	1,400	52,000	16.1	60,000	4.6	58,500	25.7	48,500	3.8	56,500	22.0	43,000	3.4								

## AHRI / ISO 13256-1 PERFORMANCE DATA - FULL LOAD - PAIRED WITH CE CONDENSING SECTION

ENTERING WATER TEMPERATURES																						
			86°F				68°F				59°F				50°F				77°F		32°F	
			WATER LOOP				GROUND WATER				GROUND WATER				GROUND LOOP							
CAPACITY AND EFFICIENCY DATA																						
MODEL	FLUID FLOW RATE (GPM)	AIR FLOW (CFM)	COOLING CAPACITY (WLHP)	EER (WLHP)	HEATING CAPACITY (WLHP)	COP (WLHP)	COOLING CAPACITY (GWHP)	EER (GWHP)	HEATING CAPACITY (GWHP)	COP (GWHP)	COOLING CAPACITY (GLHP)	EER (GLHP)	HEATING CAPACITY (GLHP)	COP (GLHP)								
DX025	6	800	26,000	15.5	30,000	5.0	29,000	23.8	25,000	4.7	27,000	18.0	20,000	4.1								
DX035	9	1,200	37,000	14.6	44,000	4.6	42,000	22.5	36,000	4.2	38,500	16.8	28,000	3.6								
DX049	12	1,600	47,000	13.2	60,000	4.8	54,000	19.8	49,000	4.3	49,000	15.1	38,500	3.6								
DX061	14	2,000	60,000	13.8	73,000	4.8	68,000	21.2	59,000	4.2	63,500	16.1	49,000	3.8								
DX071	18	2,200	70,500	14.1	83,500	4.8	79,000	20.7	67,500	4.2	73,500	16.1	54,000	3.6								

## AHRI / ISO 13256-1 PERFORMANCE DATA - PART LOAD - PAIRED WITH TA CONDENSING SECTION

ENTERING WATER TEMPERATURES																						
			86°F				68°F				59°F				50°F				68°F		41°F	
			WATER LOOP				GROUND WATER				GROUND WATER				GROUND LOOP							
CAPACITY AND EFFICIENCY DATA																						
MODEL	FLUID FLOW RATE (GPM)	AIR FLOW (CFM)	COOLING CAPACITY (WLHP)	EER (WLHP)	HEATING CAPACITY (WLHP)	COP (WLHP)	COOLING CAPACITY (GWHP)	EER (GWHP)	HEATING CAPACITY (GWHP)	COP (GWHP)	COOLING CAPACITY (GLHP)	EER (GLHP)	HEATING CAPACITY (GLHP)	COP (GLHP)								
DX025	8	750	18,500	17.0	24,000	5.8	22,000	27.1	19,000	4.7	21,000	23.7	16,500	4.2								
DX035	9	1,000	26,500	18.9	30,500	6.1	30,000	32.3	25,000	5.1	29,000	27.9	22,000	4.6								
DX049	12	1,300	36,000	18.2	44,000	5.6	42,000	30.7	35,500	4.8	40,000	26.5	31,000	4.4								
DX061	14	1,500	45,000	17.0	54,000	5.4	50,500	28.0	44,500	4.6	48,500	24.3	40,000	4.2								
DX071	18	1,500	54,000	15.7	68,000	5.1	53,500	22.5	54,500	4.3	53,500	20.3	47,500	3.9								

## AHRI / ISO 13256-1 PERFORMANCE DATA - FULL LOAD - PAIRED WITH TA CONDENSING SECTION

ENTERING WATER TEMPERATURES																						
			86°F				68°F				59°F				50°F				77°F		32°F	
			WATER LOOP				GROUND WATER				GROUND WATER				GROUND LOOP							
CAPACITY AND EFFICIENCY DATA																						
MODEL	FLUID FLOW RATE (GPM)	AIR FLOW (CFM)	COOLING CAPACITY (WLHP)	EER (WLHP)	HEATING CAPACITY (WLHP)	COP (WLHP)	COOLING CAPACITY (GWHP)	EER (GWHP)	HEATING CAPACITY (GWHP)	COP (GWHP)	COOLING CAPACITY (GLHP)	EER (GLHP)	HEATING CAPACITY (GLHP)	COP (GLHP)								
DX025	8	950	25,500	15.0	32,500	4.7	29,000	22.3	27,000	4.2	26,500	17.4	21,000	3.7								
DX035	9	1,200	37,000	15.5	43,500	5.2	41,500	23.2	32,500	4.2	38,500	18.05	22,000	3.2								
DX049	12	1,700	50,000	17.7	60,500	5.1	56,500	26.6	50,000	4.7	51,500	20.5	40,000	4.3								
DX061	14	2,000	61,000	14.4	76,000	4.9	69,000	20.5	63,000	4.3	63,500	16.4	50,000	3.7								
DX071	18	2,200	67,500	13.7	89,500	4.6	72,500	18.4	71,000	4	69,000	15.3	53,000	3.4								



**BOSCH**

# Performance Data

CHILLED WATER "A" COIL DATA 80/67°F EAT 45°F EWT									
MODEL NO.	CFM	TOTAL	SENS	LATENT	LDB	LWB	GPM	WPD FT.	APD IN-WC
HY025-1	800	32,350	22,190	10,160	54.3	54.0	3.5	2.1	0.036
HY035-1	1,200	41,540	30,430	11,110	56.5	56.1	4.0	3.3	0.049
HY049-1	1,600	51,940	38,600	13,340	57.6	56.8	5.5	5.5	0.132
HY061-1	2,000	63,750	47,340	16,410	58.0	57.0	7.0	8.4	0.195
HY071-1	2,400	78,711	57,242	21,469	58.0	56.8	9.0	9.3	0.280

4 ROW "A" COIL HEATING CAPACITY												
MODEL NO.	CFM	120°F EWT 20°FΔt 65°F EDB					140°F EWT 20°FΔt 65°F EDB					
		BTUH	LAT	GPM	APD IN-WC	WPD FT	BTUH	LAT	GPM	APD IN-WC	WPD FT	
HY025-1	800	37,818	108.6	3.8	0.09	2.28	54,376	127.7	5.5	0.09	2.03	
HY035-1	1,200	53,870	106.4	5.4	0.16	2.19	77,751	124.7	7.9	0.16	3.94	
HY049-1	1,600	75,333	108.4	7.6	0.11	5.12	107,610	127.0	10.9	0.11	7.40	
HY061-1	2,000	90,101	106.5	9.1	0.16	5.79	129,224	124.6	13.1	0.16	9.83	
HY071-1	2,400	103,873	104.9	10.5	0.22	7.20	149,456	122.4	15.1	0.22	12.31	

  

MODEL NO.	CFM	160°F EWT 20°FΔt 65°F EDB					180°F EWT 20°FΔt 65°F EDB				
		BTUH	LAT	GPM	APD IN-WC	WPD FT	BTUH	LAT	GPM	APD IN-WC	WPD FT
HY025-1	800	70,700	146.5	7.2	0.09	3.09	86,916	165.2	8.9	0.09	3.32
HY035-1	1,200	101,327	142.9	10.3	0.16	4.68	124,762	160.9	12.8	0.16	6.44
HY049-1	1,600	139,501	145.4	14.2	0.11	10.91	179,219	163.7	17.6	0.11	14.85
HY061-1	2,000	167,902	142.4	17.1	0.16	14.53	206,377	160.1	21.2	0.16	19.88
HY071-1	2,400	194,543	139.7	19.8	0.22	18.27	239,403	157.0	24.6	0.22	23.20



**BOSCH**

# Dimensional Data For DX Models

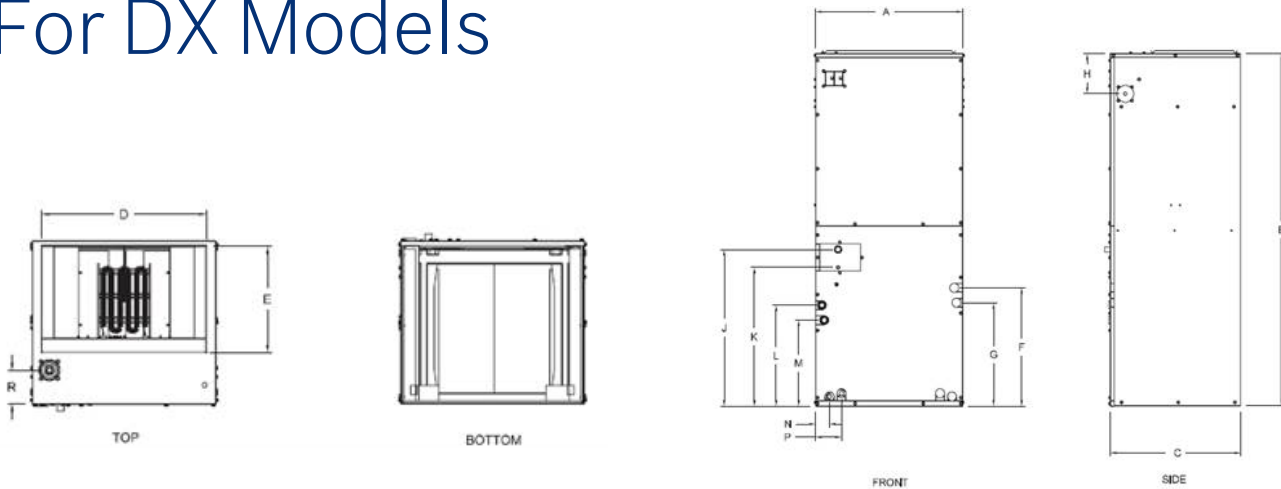

Model	A	B	C	D	E	F	G	H	J	K	L	M	N	P	R
DX025	17.5	43	21	15.5	12.5	13.5	11	6.75	16.75	14	11	10.75	2	1.5	5
DX035	21	48	21	19	12.5	14.5	13	6.75	20	17	12.75	10.3	2.3	4.35	5
DX049	24.5	58.75	21.75	23.35	21.25	19.75	17.25	6.75	26	23	16.75	14.35	2.3	4.35	4.5
DX061	24.5	58.75	21.75	23.35	21.25	19.75	17.25	6.75	26	23	16.75	14.35	2.3	4.35	4.5
DX071	24.5	58.75	21.75	23.35	21.25	19.75	17.25	6.75	26	23	16.75	14.35	2.3	4.35	4.5

# Dimensional Data For HY Models

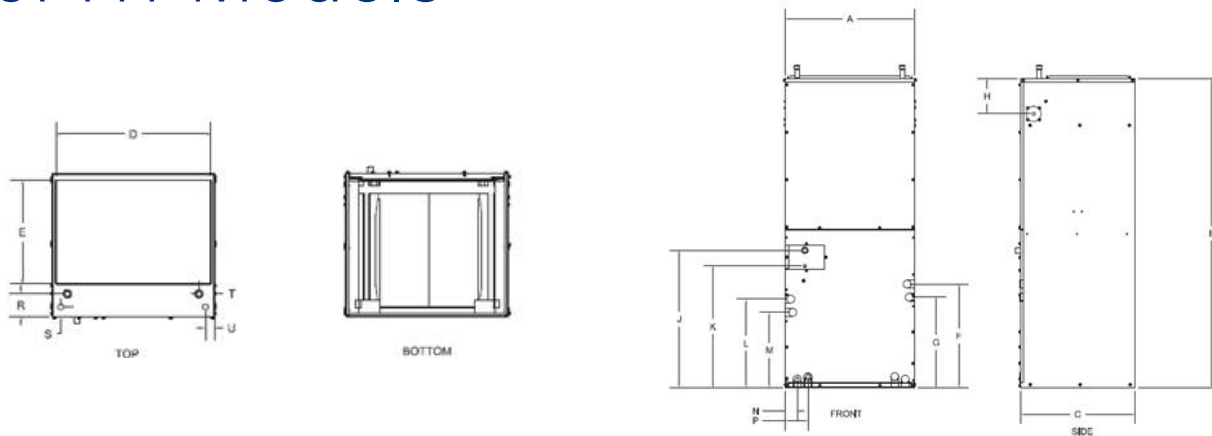

Model	A	B	C	D	E	F	G	H	J	K	L	M	N	P	R	S	T	U
HY025	17.5	43	21	16	15	13.5	11	6.75	16.75	14	11	11	2	1.5	3.3	1	1.5	1
HY035	21	48	21	19	15	14.5	13	6.75	20	17	13	10.3	2.3	4.35	3.75	1.75	2.5	1.5
HY049	24.5	58.75	21.75	23.5	15.75	19.75	17.25	6.75	26	23	16.75	14.35	2.3	4.35	3.5	1.5	2.25	1.25
HY061	24.5	58.75	21.75	23.5	15.75	19.75	17.25	6.75	26	23	16.75	14.35	2.3	4.35	3.5	1.5	2.25	1.25
HY071	24.5	58.75	21.75	23.5	15.75	19.75	17.25	6.75	26	23	16.75	14.35	2.3	4.35	3.5	1.5	2.25	1.25



**BOSCH**