

TECHNICAL GUIDE

TOUCH SCREEN COMMUNICATING CONTROL MODEL: S1-TTSCC01



DESCRIPTION

Johnson Controls, Unitary Products specializes in creating a customized home comfort system tailored to the homeowner's needs with our broad selection of residential heating and cooling products. The Communicating Control System is the ultimate control center for all of your system components. When you add a Touch Screen Communicating Control to a compatible modulating variable-speed furnace or air handler, and a premium air-conditioner or heat pump, you'll enjoy longer heating and cooling cycles at lower fan speeds for a more consistent temperature throughout your home, better humidity control, as well as a more energy-efficient comfort system.

WARRANTY

Standard 5-year limited parts warranty.

FEATURES & BENEFITS

- High definition color, touch screen user interface.
- Incorporates graphics and animation.
- 4-wire installation from each component in the system.
- Intuitive on-screen prompts for ease of installation and service.
- Automatic system configuration – plug & play.
- System diagnostics for ease of troubleshooting.
- Detailed system forced operation.
- Complete integration of temperature control, humidity control, and ventilation in every season.
- Ventilation limits to ensure outside air is not introduced in extreme hot or cold conditions - no extra heating or cooling load
- Automatic Humidity Control – set it and forget it. No longer requiring manual setting for humidification or dehumidification – can be switched to be used in manual mode
- Programmable or non-programmable mode selection
 - Advanced or normal programmable mode view selection
- 7-day programmability with 2, 3, or 4 periods per day
- Patented pending Quick Heat/Quick Cool functionality
- Day-at-a-glance programming for simplified ease of use
- Seasonal programming
- Easy timed-override schedule
- Simplified vacation schedules
- Programmable fan by period
- Fan speed adjustability - as low as 17% to 100% in 1% increments
- Energy saving opportunity
- Indoor Air Quality pop-up replacement reminders
- General maintenance reminder messaging
- Comfort Studio software to allow programming the Communicating Control with the use of a thumb drive
 - Allows the dealer to display the company logo

MODEL NUMBER NOMENCLATURE

S1 - T TS C C 01 A

S1	Source 1
T	Tag in a bag
TS	Touch Screen
C	Communicating
C	Control
01	1st Generation
A	Revision A

PRODUCT DATA INFORMATION**Compatible Communicating Products**

Model Description	YORK	COLEMAN	LUXAIRE
Air Conditioning	CZE, CZF, CZH	AC5, AC6, AC8	AL5, AL6, AL8
Heat Pumps	YZB, YZE, YZF, YZH	HC5, HC6, HC8	HL5, HL6, HL8
Gas Furnaces	YPLC, YP9C, TM9V, TM8V	CPLC, CP9C, TM9V, TM8V	LPLC, LP9C, TM9V, TM8V
Air Handlers	MV, AV*, AHV	MV, AV*, AHV	MV, AV*, AHV

Physical Characteristics**Dimensions:**

See drawing

Appearance:

Plastic, white color, textured

Electrical Characteristics/Communication**Input Volts/Amps 24VAC:**

Each device in the communicating system has a four-pin connector labeled A+, R, C, B-. It is recommended that the following color code be used when wiring each device:

- A+ Green = Data A+
- R Red = 24VAC (Hot)
- C Black = 24VAC (Com)
- B- White = Data B-

Environmental Requirements**Operating Temperature/Relative Humidity:**

User interface and all sensors: 32F to 104F / 0C to 40C, 95% RH non-condensing.

Storage Temperature/Relative Humidity:

User interface: -40F to 134F / -40C to 56.7C, 95% RH non-condensing.

Wiring Requirements**Power supply:**

Dedicated 24VAC, 40 va, 60 Hz, via indoor equipment A+, R, C, B- Connector. Isolated transformer, field supplied.

Wiring material:

Standard thermostat wire 18 to 24 gauge.

Feature Specifications

- Temperature set point range: 40F to 90F / 4.4C to 32.2C
- Separate heat and cool setpoints
- Programming days: 7 day
- Programming periods:
 - 2 Periods: Day, Away
 - 3 Periods: Day, Away, Sleep
 - 4 Periods: Awake, Away, Return, Sleep
- Non-Programmable
- Auto changeover (may be disabled)
- Programmable fan (installer selectable)
- Humidity Sensor Offsets
- Smart Recovery (in heating and cooling)
- Copy functions: Copy period, day and zone
- Permanent memory
- Humidity display and control
- Temperature sensor offsets (indoor and outdoor)

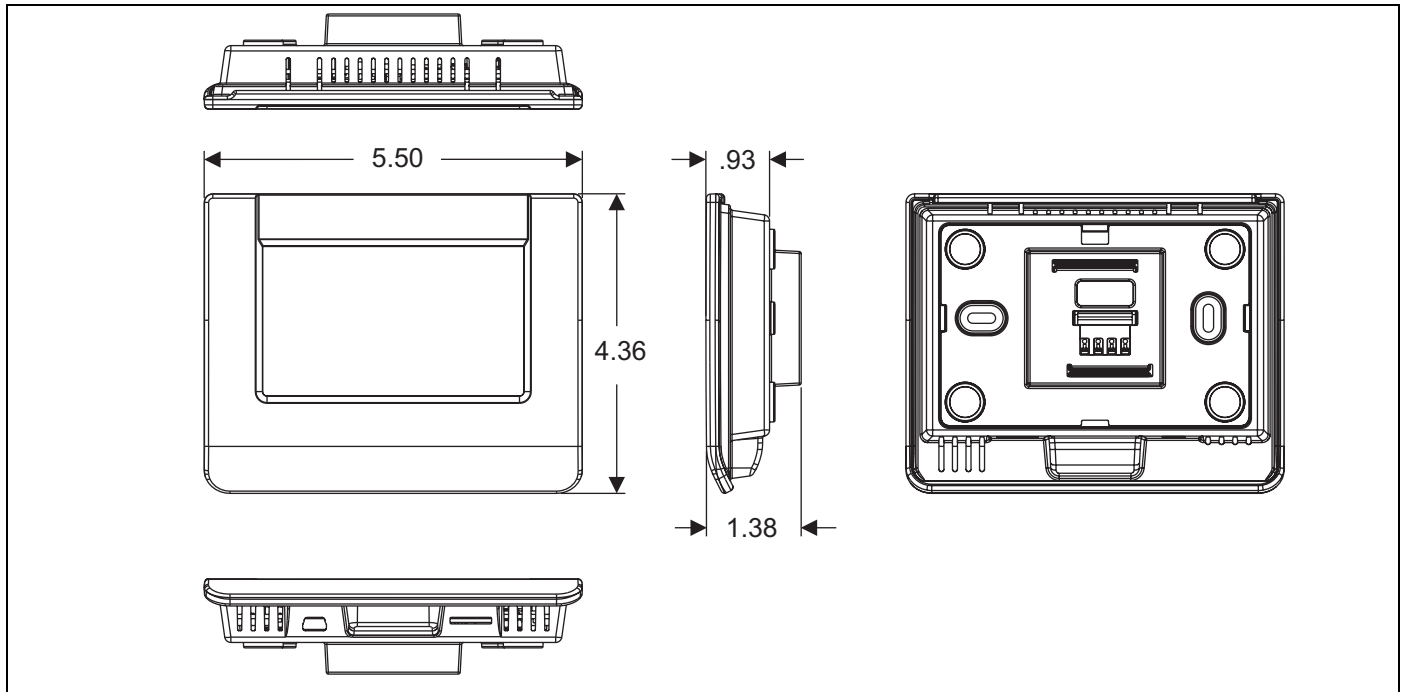
PRODUCT DIMENSIONS**EQUIPMENT****Equipment**

PART NUMBER	DESCRIPTION
S1-TTSCC01	Touch Screen Communicating Control

Repair Parts

PART NUMBER	DESCRIPTION
S1-02815904000	Face Plate
S1-02815905000	Rear Housing
S1-02815906000	Mounting Plate

Optional Accessories

PART NUMBER	DESCRIPTION
S1-02815909000	Hard Surface Mounting Plate and Decorative Backplate
S1-03102965000	USB Adapter
S1-33102953000	Non-Communicating Furnace and Air Handler Auxiliary Board
S1-02542694000	Wire Harness
S1-CVENTDEH01	ERV/HRV, Ventilation Control Damper and Whole Home Dehumidifier Auxilliary Board
S1-02543570000	6' Service Wire Harness

NOTES